

轮毂专用车刀

Special lathe tools for wheel hub

石油管道专用车刀

Special lathe tools for petroleum pipelines

精益求精 铸造品质

Seeking excelsior dedication and
build high quality

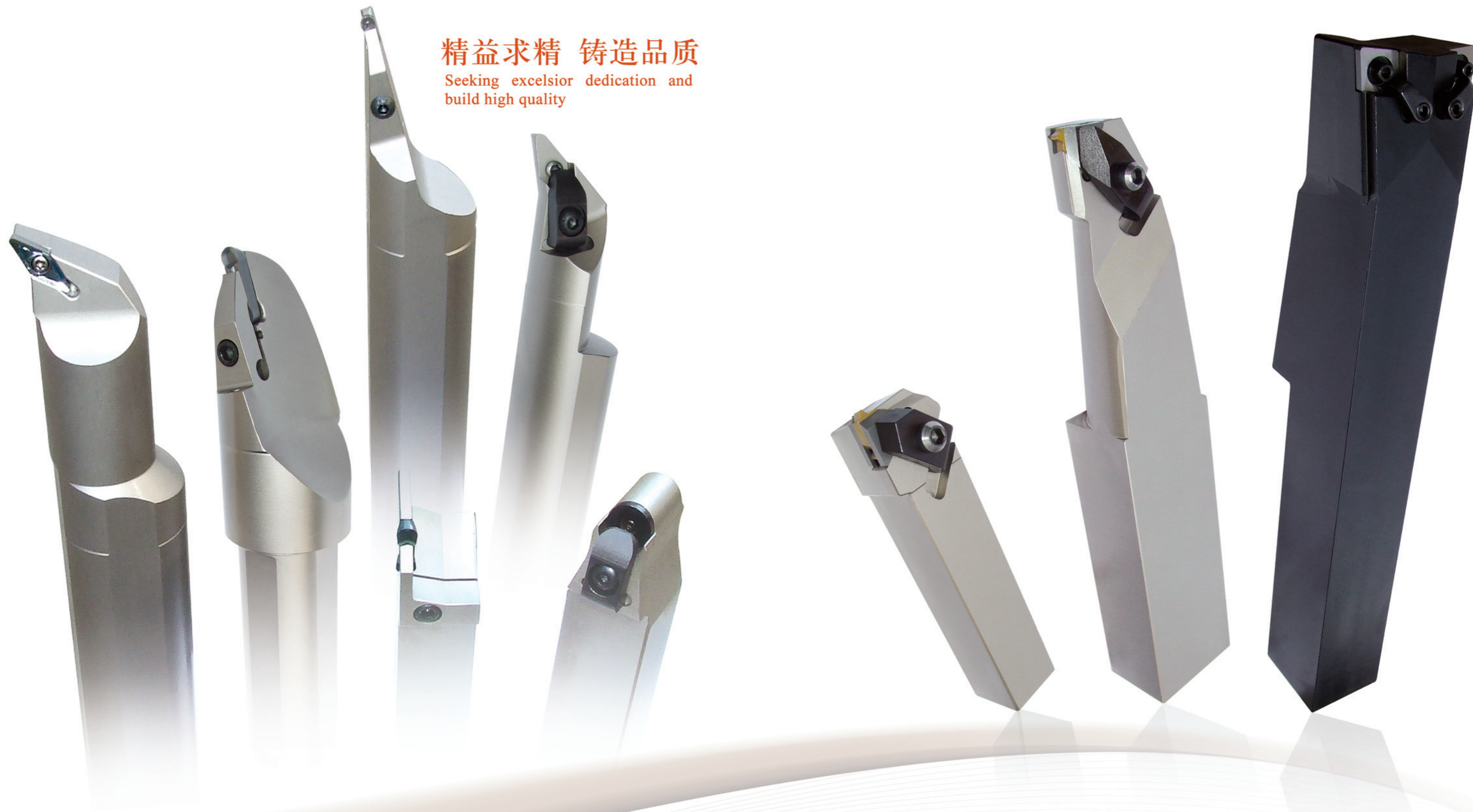



非标刀具

Non-standard cutting tools



轴承专用车刀

Special cutting tools for bearing



此款刀具可根据客户要求设计定做，欢迎来函预约订购！

This type of cutting tools can be customized according to customers' requirements, for which your inquiries are welcome.

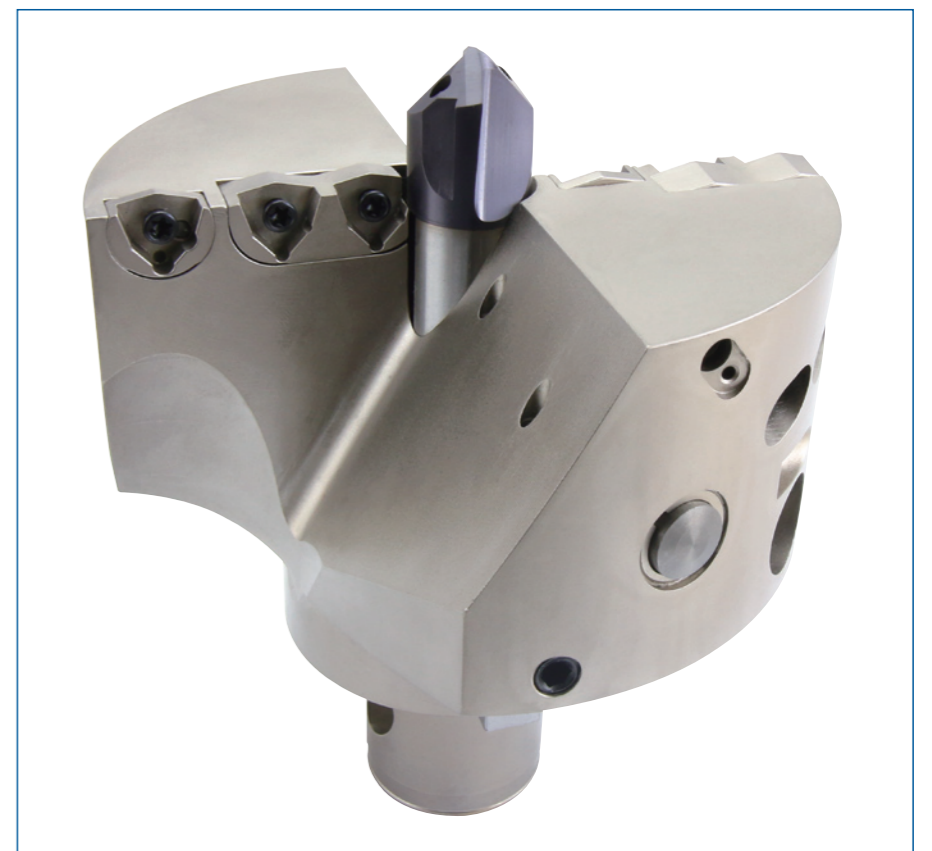
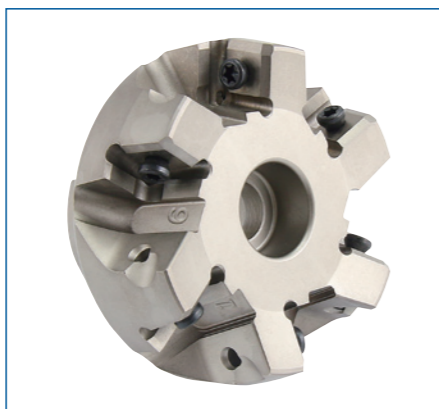
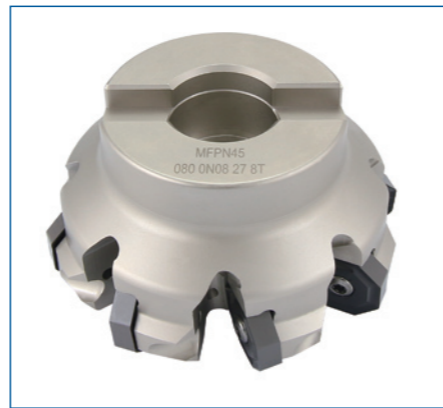
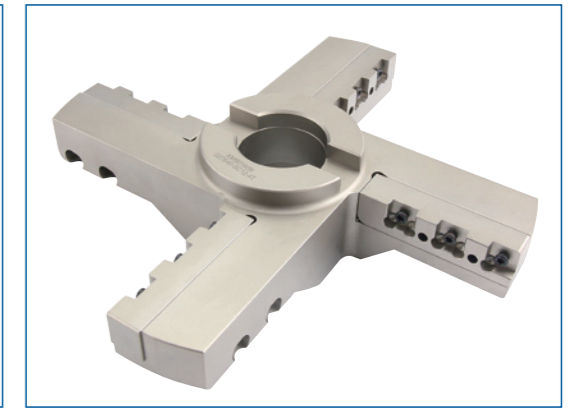

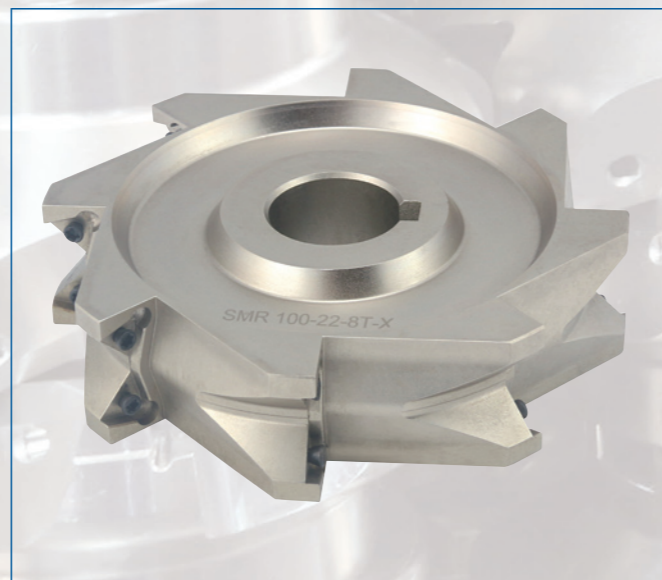
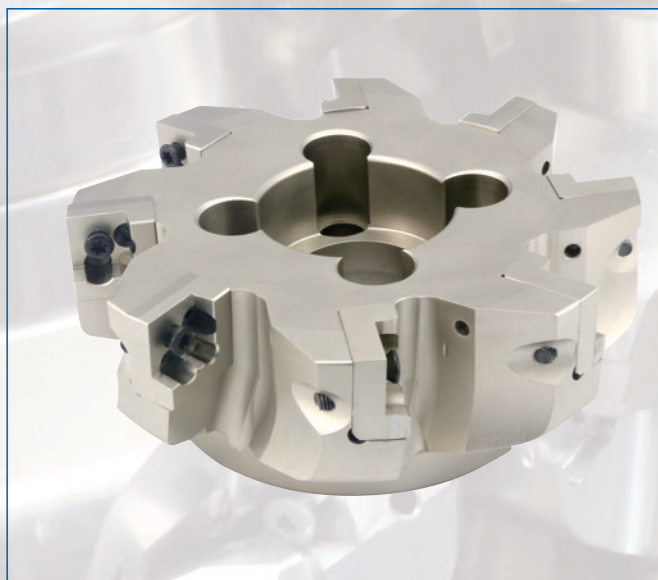
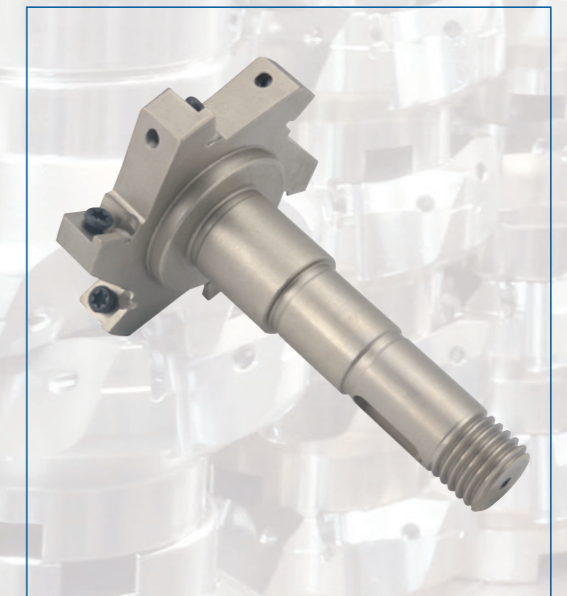
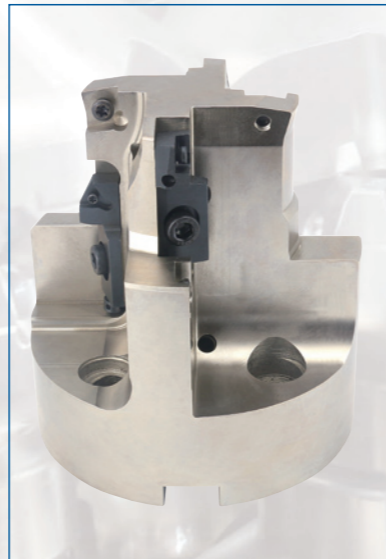
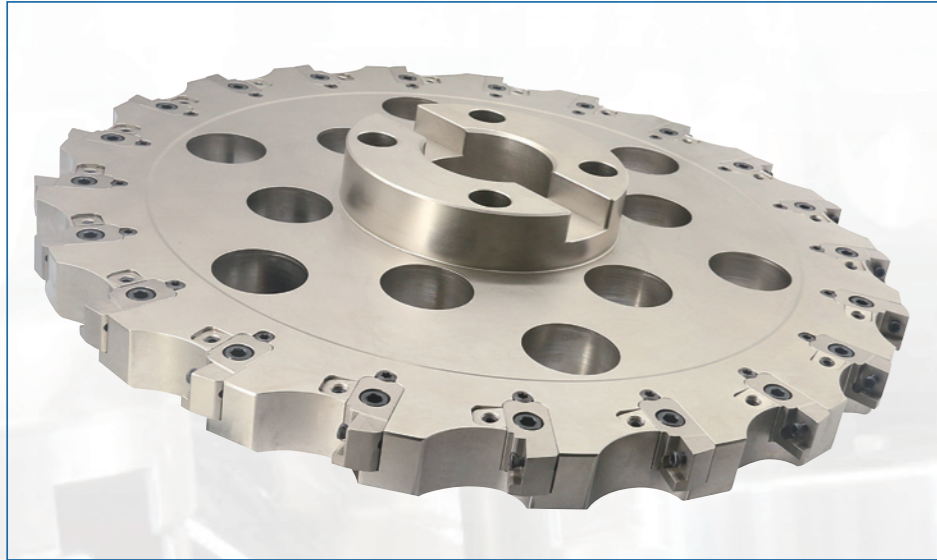

总目录

INDEX



A 铣刀系列 Milling Cutter Series A01-A94



B 外圆车刀防震系列 Type Circulak Knife Shockproof Sekies B01-B06



C 外圆车刀系列 Type circular knife series C01-C26



D 外圆刀(螺钉型) Excicle blade (screw type) D01-D15



E 钨钢抗震刀杆系列 Tungsten steel anti-knock tool bar series E01-E07



F 换头防震镗刀系列 Head removable & anti-shock boring cutter F01-F05



G 压板型镗刀系列 Platen type boring cutter series G01-G14



H 螺钉型镗刀 Screw type boring cutter carrier H01-H17



I 割刀 Cutting knife I01-I38



J 螺纹刀系列 Thread cutter series J01-J04



K 小刀夹、镗刀头、刀柄系列 Knife, cutter head and handle series K01-K20

TCAP多功能钻车刀系列(A1)



大孔钻(A2)



VMD连接杆(A3)



百变魔术刀盘(A4-A6)

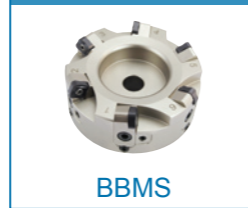

ASM系列锁牙刀头(A7)



MFPN66°刀盘系列(A33)



TEN09R°刀盘系列(A34)



FMZ88°刀盘系列(A35)



FME75°刀盘系列(A36)



FMA45°刀盘系列(A37)

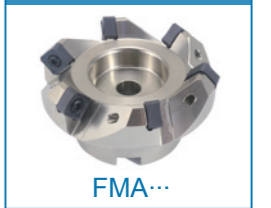

日立ASM07系列铣刀杆(A8)



BAP300系列锁牙刀头(A9)



直杆铣刀BAP系列(A10)



变杆铣刀BAP系列(A11)



BAP 90°刀盘系列(A12)

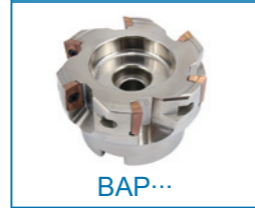

SN1206 45°刀盘系列(A38)



SN1206 45°刀盘系列(A39)



MFC45°-07刀盘系列(A40)

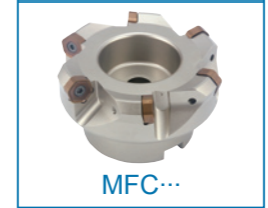

MFC45°-09刀盘系列(A41)



TFM45°刀盘系列(A42)

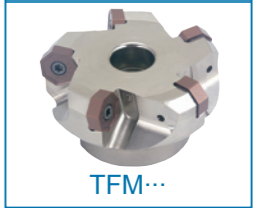

KAP 75°刀盘系列(A13)



BAP 90°刀盘系列(A14)



MEC铣刀杆系列(A15)

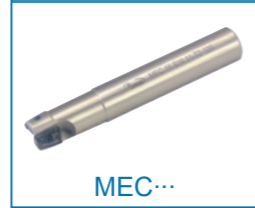

MEC 90°刀盘系列(A16)



R390 90°刀盘系列(A17)



TFM55°刀盘系列(A43)

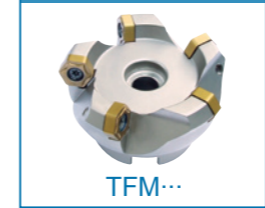

SE 13T3 45°刀盘系列(A44)



OD 45°刀盘系列(A45)

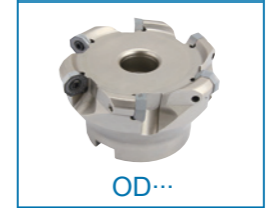

SE 1204 45°刀盘系列(A46)



SN 75°开粗刀盘系列(A47)



WEX 90°刀盘系列(A18)



TPS 90°刀盘系列(A19)



TFM 90°刀盘系列(A20)



APX 90°刀盘系列(A21)



MFWN系列锁牙刀头(A22)

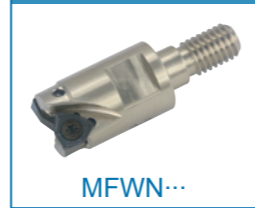

CBN 75°精加工带修光刃刀盘系列(A48)



TP 90°刀盘系列(A49)



SP 75°刀盘系列(A50)



BRP系列锁牙刀头(A51)



EMR铣刀杆系列(A52)



MFWN车铣复合专用刀杆(A23)

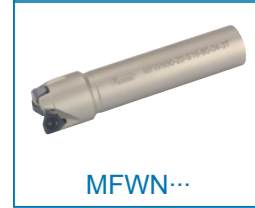

MFWN铣刀杆系列(A24)

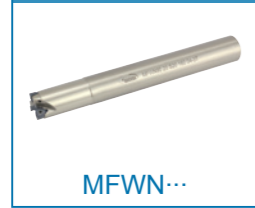

MFWN铣刀杆系列(A25)

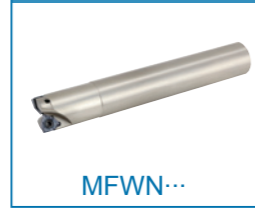

MFWN90°刀盘系列(A26)



WN90°刀盘系列(A27)



直杆铣刀SBRP系列(A53)



变杆铣刀SBRP系列(A54)



直杆铣刀BRP/D系列(A55)



变杆铣刀BRP/D系列(A56)



BRP SBRP刀盘系列(A57)



4NTE90系列锁牙刀头(A28)



4NTE90铣刀杆系列(A29)



4NTE90铣刀杆系列(A30)



4N TF90刀盘系列(A31)

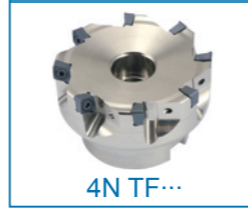

MFSN 88°刀盘系列(A32)



MFH01系列锁牙刀头(A58)

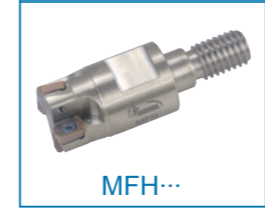

MFH铣刀杆系列(A58)

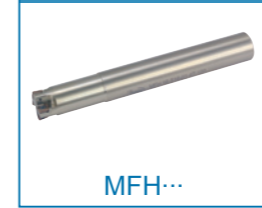

MFH03系列锁牙刀头(A59)



MFH03铣刀杆系列(A60)

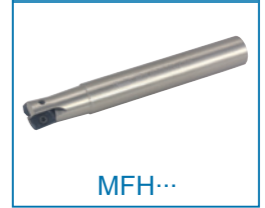

MFH03高进给刀盘系列(A61)

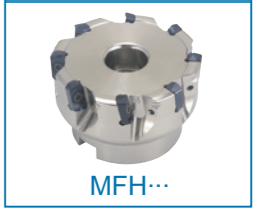

铣刀系列

MILLING CUTTER SERIES

目录

MFH10系列锁牙刀头(A62)

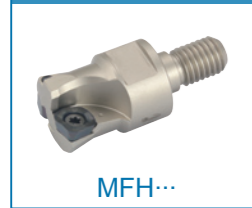

MFH...

MFH10铣刀杆系列(A63)

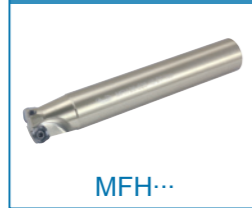

MFH...

MFH10高进给刀盘系列(A64)



MFH...

EXN02 03系列锁牙刀头(A65)



EXN...

EXN02 03铣刀杆系列(A66)

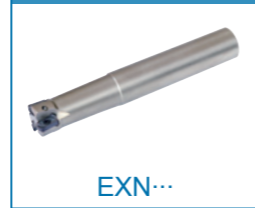

EXN...

AP1604 倒角刀系列(A91)

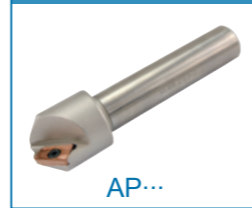

AP...

SC 倒角刀系列(A91)



SC...

合金防震螺纹铣刀系列(A92)



SR...

螺纹铣刀系列(A93)



SR...

螺丝沉头刀系列(A94)



CH...

TXN高进给刀盘系列(A67)

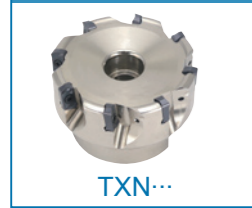

TXN...

TEBL 04 06系列锁牙刀头(A68)



TEBL...

TEBL04 06铣刀杆系列(A69)



TEBL...

TEMBL 刀盘系列(A70)



TEMBL...

SDMT 1205/1505高进给刀盘系列(A71)



SDMT...

AP 玉米刀盘系列(A72)

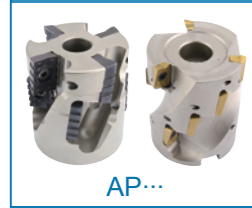

AP...

BAP直杆玉米铣刀杆(A73)



BAP...

BAP套式玉米铣刀盘系列(A74)



BAP...

AP 一体式玉米刀盘系列(A75)



AP...

SN 心轴式三面刃系列(A76)



SN...

SN 盘式三面刃系列(A77)



SN...

CN 心轴式三面刃系列(A78)



CN...

CN-S 心轴式三面刃系列(A79)



CN-S...

CN 盘式三面刃系列(A80)



CN...

GM 刀杆系列(A81)



GM...

GM 刀盘系列(A81)



GM...

CC T形刀系列(A82)



CC...

SD T形刀系列(A83)



SD...

SMC 盘式三面刃系列(A84)



SMC...

RP T形刀系列(A85)



RP...

TMR 盘式三面刃系列(A86)

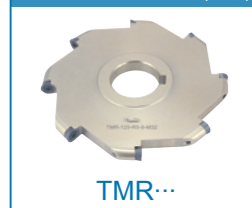

TMR...

燕尾刀刀盘系列(A87)



YW...

燕尾刀刀杆系列(A88)



YW...

CC 反拉刀系列(A89)



CC...

TC 倒角刀系列(A90)



TC...

TCAP多功能钻车刀系列
TCAP MULTIFUNCTIONAL DRILLING TOOL SERIES

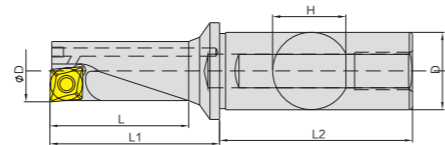

型号 Model		φD	D	L	L1	L2	H	螺丝 Screw	扳手 Wrench
TCAP 08R/L-2.25D	XCMT 040104R TC	8	10	18	22	38	9.5	LD24261840T6-20	T6
TCAP 10R/L-2.25D	XCMT 050204 TC	10	12	22.5	27.5	42	11.5	LD30252040T6-20	T6
TCAP 12R/L-2.25D	XCMT 060204 TC	12	16	27	33	45	15	LD30252240T6-20	T6
TCAP 14R/L-2.25D	XCMT 070304 TC	14	16	31.5	38.5	45	15	LD35202560T8-30	T8
TCAP 16R/L-2.25D	XCMT 080304 TC	16	20	36	44	50	19	LD40303064T8-40	T8
TCAP 20R/L-2.25D	XCMT 10T304 TC	20	25	45	55	56	24	LD50203510T15-60	T15
TCAP 08R/L-3.25D	XCMT 040104R TC	8	10	26	30	38	9.5	LD24261840T6-20	T6
TCAP 10R/L-3.25D	XCMT 050204 TC	10	12	32.5	37.5	42	11.5	LD30252040T6-20	T6
TCAP 12R/L-3.25D	XCMT 060204 TC	12	16	39	45	45	15	LD30252240T6-20	T6
TCAP 14R/L-3.25D	XCMT 070304 TC	14	16	45.5	52.5	45	15	LD35202560T8-30	T8
TCAP 16R/L-3.25D	XCMT 080304 TC	16	20	52	60	50	19	LD40303064T8-40	T8
TCAP 20R/L-3.25D	XCMT 10T304 TC	20	25	65	75	56	24	LD50203510T15-60	T15

大孔钻
LARGE HOLE DRILL

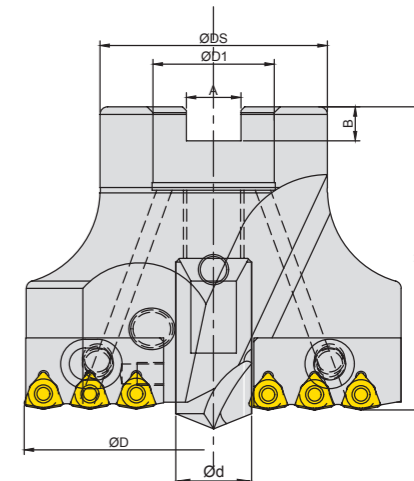

型号 Model		适用条件						螺丝 Screw	扳手 Wrench	
		调节范围 φD(MIN)	调节范围 φD(MAX)	φd	φDs	φD1	A			B
VMD45-50M16-25	WC03	45	50	16	25	16	8.4	6	M2.2	T6
VMD50-55M16-25	WC04	50	55	22	25	16	8.4	6	M2.5	T8
VMD55-60M22-32	WC05	55	60	22	32	22	10.4	7	M3	T8
VMD60-65M22-32		60	65	27	32	22	10.4	7		
VMD65-70M22-40	WC06	65	70	16	40	22	10.4	7	M4/M3.5	T15
VMD70-75M22-40		70	75	22	40	22	10.4	7		
VMD75-80M27-50		75	80	22	50	27	12.4	7		
VMD80-85M27-50	WC06	80	85	27	50	27	12.4	7	M4/M3.5	T15
VMD85-90M27-50		85	90	16	50	27	12.4	7		
VMD90-95M27-50	WC05	90	95	22	50	27	12.4	7	M3	T8
VMD95-100M32-60		95	100	22	60	32	14.4	9		
VMD100-105M32-60		100	105	27	60	32	14.4	9		
VMD105-110M32-60	WC06	105	110	16	60	32	14.4	9	M4/M3.5	T15
VMD110-115M32-60		110	115	22	60	32	14.4	9		
VMD115-120M40-70		115	120	22	70	40	16.4	9		
VMD120-125M40-70		120	125	27	70	40	16.4	9		
VMD125-130M40-70		125	130	16	70	40	16.4	9		
VMD130-135M40-70		130	135	22	70	40	16.4	9		
VMD135-140M40-70	WC08	135	140	22	70	40	16.4	9	M5	T20
VMD140-150M40-70		140	150	27	70	40	16.4	9		
VMD150-160M40-70		150	160	16	70	40	16.4	9		
VMD160-170M40-70		160	170	22	70	40	16.4	9		
VMD170-180M40-70		170	180	22	70	40	16.4	9		
VMD180-190M40-70		180	190	27	70	40	16.4	9		
VMD190-200M40-70	WC08	190	200	27	70	40	16.4	9	M5	T20
VMD200-210M50-80		150	160	16	70	40	16.4	9		
VMD210-220M50-80		160	170	22	70	40	16.4	9		
VMD220-230M50-80		170	180	22	70	40	16.4	9		
VMD230-240M50-80	WC08	180	190	27	70	40	16.4	9	M5	T20
VMD240-250M50-80		190	200	27	70	40	16.4	9		

A

铣刀系列
Milling cutter series

A

铣刀系列
Milling cutter series

VMD连接杆
VMD CONNECTING ROD

新品

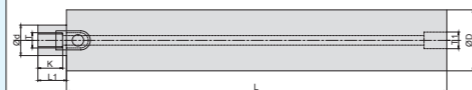

A

铣刀系列
Milling cutter series

型号 Model	φd	T	K	L1	T1	L	φD
VMD C25M16-150	16	M8	13	15	ZG1/8	150	25
VMD C25M16-200	16	M8	13	15	ZG1/8	200	25
VMD C25M16-300	16	M8	13	15	ZG1/8	300	25
VMD C25M16-500	16	M8	13	15	ZG1/8	500	25
VMD C32M22-150	22	M8	13	15	ZG1/8	150	32
VMD C32M22-200	22	M8	13	15	ZG1/8	200	32
VMD C32M22-300	22	M8	13	15	ZG1/8	300	32
VMD C32M22-500	22	M8	13	15	ZG1/8	500	32
VMD C32M22-750	22	M8	13	15	ZG1/8	750	32
VMD C32M22-1000	22	M8	13	15	ZG1/8	1000	32
VMD C40M22-200	22	M10	13.5	19	ZG1/8	200	40
VMD C40M22-300	22	M10	13.5	19	ZG1/8	300	40
VMD C40M22-500	22	M10	13.5	19	ZG1/8	500	40
VMD C40M22-750	22	M10	13.5	19	ZG1/8	750	40
VMD C40M22-1000	22	M10	13.5	19	ZG1/8	1000	40
VMD C50M27-200	27	M12	14.5	19	ZG1/4	200	50
VMD C50M27-300	27	M12	14.5	19	ZG1/4	300	50
VMD C50M27-500	27	M12	14.5	19	ZG1/4	500	50
VMD C50M27-750	27	M12	14.5	19	ZG1/4	750	50
VMD C50M27-1000	27	M12	14.5	19	ZG1/4	1000	50
VMD C50M27-1500	27	M12	14.5	19	ZG1/4	1500	50
VMD C60M32-300	32	M16	16.5	19	ZG3/8	300	60
VMD C60M32-500	32	M16	16.5	19	ZG3/8	500	60
VMD C60M32-750	32	M16	16.5	19	ZG3/8	750	60
VMD C60M32-1000	32	M16	16.5	19	ZG3/8	1000	60
VMD C60M32-1500	32	M16	16.5	19	ZG3/8	1500	60
VMD C60M32-2000	32	M16	16.5	19	ZG3/8	2000	60
VMD C70M40-300	40	M16	16.5	24	ZG1/2	300	70
VMD C70M40-500	40	M16	16.5	24	ZG1/2	500	70
VMD C70M40-750	40	M16	16.5	24	ZG1/2	750	70
VMD C70M40-1000	40	M16	16.5	24	ZG1/2	1000	70
VMD C70M40-1500	40	M16	16.5	24	ZG1/2	1500	70
VMD C70M40-2000	40	M16	16.5	24	ZG1/2	2000	70
VMD C80M50-300	50	M16	16.5	29	ZG1/2	300	70
VMD C80M50-500	50	M16	16.5	29	ZG1/2	500	70
VMD C80M50-750	50	M16	16.5	29	ZG1/2	750	70
VMD C80M50-1000	50	M16	16.5	29	ZG1/2	1000	70
VMD C80M50-1500	50	M16	16.5	29	ZG1/2	1500	70
VMD C80M50-2000	50	M16	16.5	29	ZG1/2	2000	70

百变魔术刀盘
MAGIC KNIFE DISC

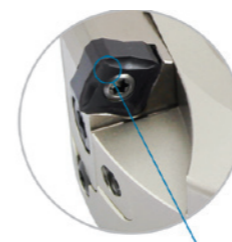

四角刀片、两面用八角、
正反用16角、高低用32角。

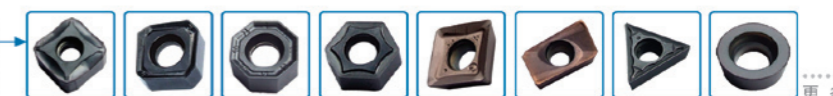

1. 每个刀盘刀夹可换，可装不同型号的刀片。

2. 加紧模式采用双重夹紧，可以轻切削，也可以重切削。

3. 上下精度可以自由调节。 **备注：可根据客户需求定做刀夹**

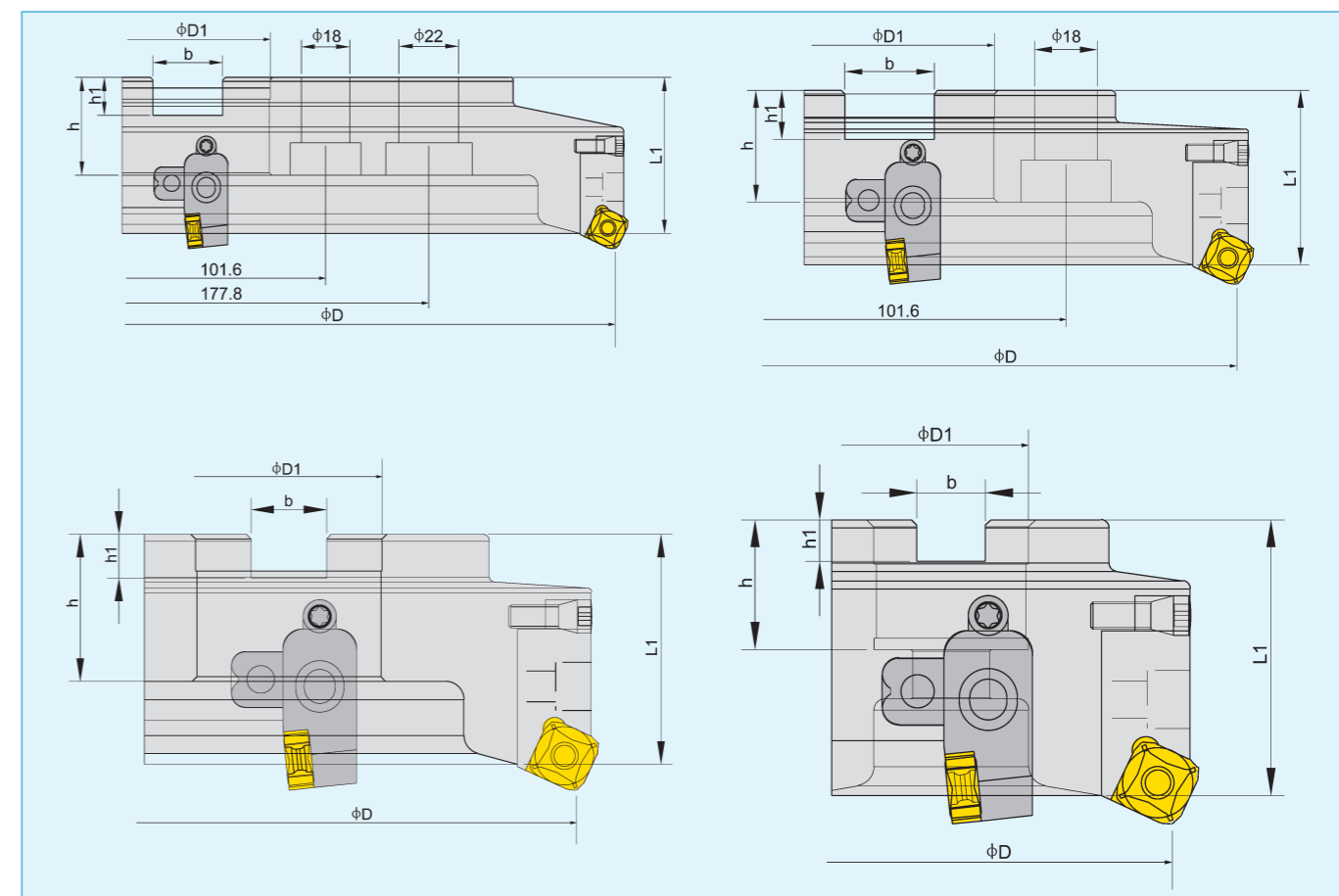

A

铣刀系列
Milling cutter series

百变魔术刀盘
MAGIC KNIFE DISC

型号 Model	刀夹 Tool holder	∅D	∅D1	L1	h	h1	b	BBMS DJ	压板 BYB	螺丝 TJLS	螺丝 DGD	螺丝 ST	螺钉 LD	扳手
BBMS DP 63 22 4T	根据所使用刀片选用刀夹	63	22	50	20	6.3	10.4	BBMS DJ	1210	0510	0620	0625	4*10	L1.5 L3.0 L5.0 T15
BBMS DP 80 27 5T		80	37	50	23	7	12.4							
BBMS DP 100 32 6T		100	32	50	24	8	14.4							
BBMS DP 125 40 8T		125	40	50	32	9	16.4							
BBMS DP 160 40 10T		160	40	50	32	9	16.4							
BBMS DP 200 60 12T		200	60	50	32	14	25.7							
BBMS DP 250 60 14T		250	60	50	32	14	25.7							
BBMS DP 315 60 16T		315	60	58	36	14	25.7							
BBMS DP 350 60 18T		350	60	58	36	14	25.7							
BBMS DP 400 60 22T		400	60	65	42	14	25.7							
BBMS DP 450 60 24T		450	60	65	42	14	25.7							
BBMS DP 500 60 26T		500	60	65	42	14	25.7							

注：刀片直径不大于12.75mm都可以做

BBMS DJ 35 SNMT 1205 65°

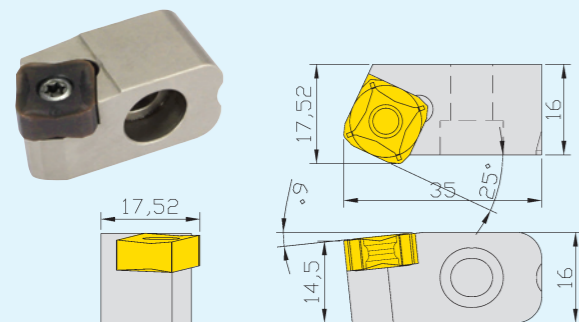

最大切深:8mm

余偏角:65°

Maximum cutting depth:8mm
More than Angle:65°

BBMS DJ 35 H07

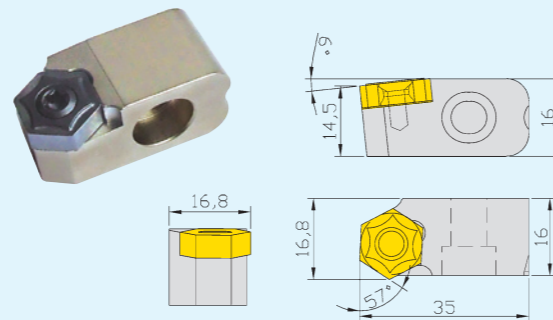

最大切深:4mm

余偏角:57°

Maximum cutting depth:4mm
More than Angle:57°

BBMS DJ 36 1604

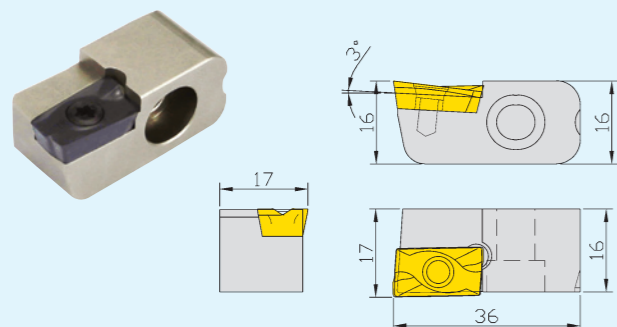

最大切深:14mm

余偏角:90°

Maximum cutting depth:14mm
More than Angle:90°

BBMS DJ 35 SOMT 12

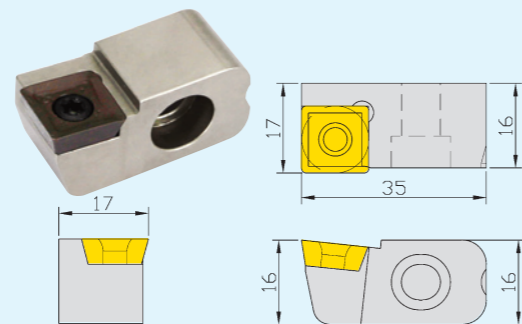

最大切深:10mm

余偏角:90°

Maximum cutting depth:10mm
More than Angle:90°

百变魔术刀盘
MAGIC KNIFE DISC

BBMS DJ 35 45° OFKT05T3A FTN

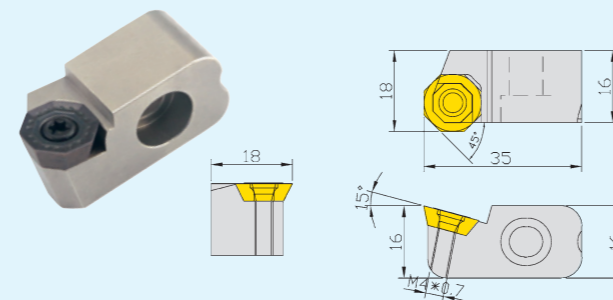

最大切深:3.5mm

余偏角:45°

Maximum cutting depth:3.5mm
More than Angle:45°

BBMS DJ 36 SN1206

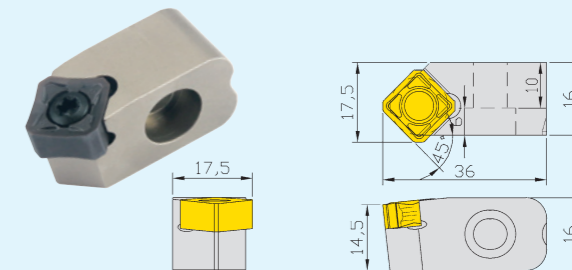

最大切深:6mm

余偏角:45°

Maximum cutting depth:6mm
More than Angle:45°

BBMS DJ 36 45° LNGX1205

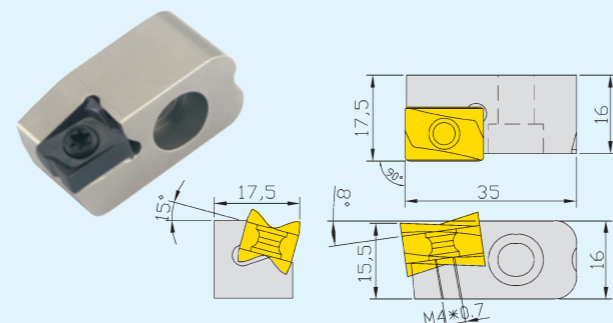

最大切深:15mm

余偏角:90°

Maximum cutting depth:15mm
More than Angle:90°

BBMS DJ 35 XHNU 0605ANR-WLWTT8080

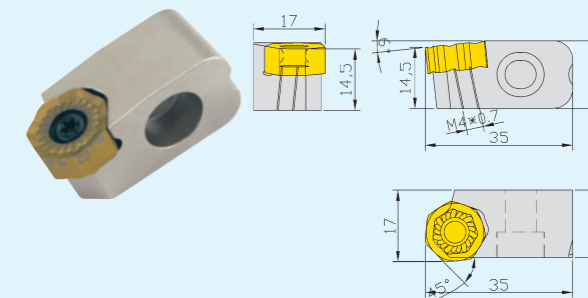

最大切深:4mm

余偏角:45°

Maximum cutting depth:4mm
More than Angle:45°

BBMS DJ 36 22° WXC080612

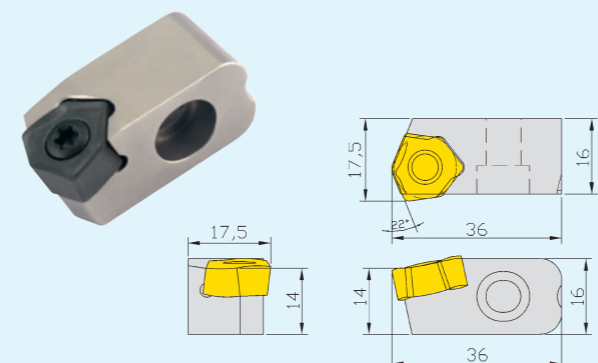

最大切深:1.8mm

余偏角:22°

Maximum cutting depth:1.8mm
More than Angle:22°

BBMS DJ 36 45° OEMT060405AE

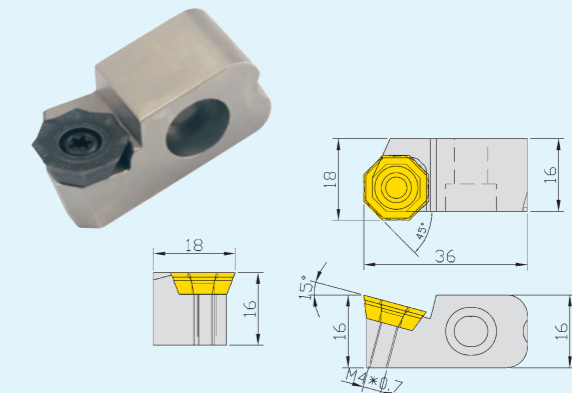

最大切深:4mm

余偏角:45°

Maximum cutting depth:4mm
More than Angle:45°

ASM系列锁牙刀头
ASM SERIES OF LOCK TOOL HEAD

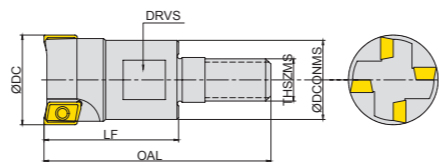

型号 Model	适用条件	螺丝 Screw	扳手 Wrench							
				刃数	φDc	φDCONMS	LF	OAL	THSZMS	DRVS
ASM0708S04M-1	JDMT0702	LD27261840 T6-20	T-6	1	8	7.8	17	28	M04	7
ASM0709S04M-1				1	9	7.8	17	28	M04	7
ASM0710S05M-2				2	10	9	17	29	M05	7
ASM0711S05M-3				3	11	9	17	29	M05	7
ASM0708S06M-1				1	8	7.8	17	32	M06	7
ASM0709S06M-1				1	9	7.8	17	32	M06	7
ASM0710S06M-2				2	10	9	17	32	M06	7
ASM0711S06M-3				3	11	9	17	32	M06	7
ASM0712S06M-3				3	12	11	17	32	M06	9
ASM0713S06M-3				3	13	11	17	32	M06	9
ASM0714S06M-3				3	14	13	17	32	M06	10
ASM0716S08M-4				4	16	15	25	43	M08	12
ASM0717S08M-4				4	17	15	25	43	M08	12

日立ASM07系列铣刀杆
HITACHI ASM07 SERIES MILLING CUTTER ROD

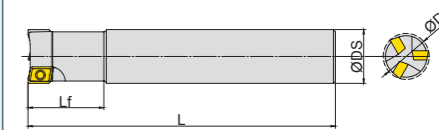

型号 Model	适用条件	螺丝 Screw	扳手 Wrench					
				刃数	φDC	φDS	L	Lf
ASM0708 S10R-1-80	JDMT0702	LD27261840 T6-20	T-6	1	08	10	80	17
ASM0708 S10R-1-100				1	08	10	100	17
ASM0709 S10R-1-100				1	09	10	100	19
ASM0710 S10R-2-80				2	10	10	80	22
ASM0710 S10R-2-100				2	10	10	100	22
ASM0710 S10R-2-120				2	10	10	120	22
ASM0711 S10R-2-80				2	11	10	80	11
ASM0711 S10R-2-100				2	11	10	100	11
ASM0711 S10R-2-120				2	11	10	120	11
ASM0712 S12R-3-80				3	12	12	80	26
ASM0712 S12R-3-100				3	12	12	100	26
ASM0712 S12R-3-120				3	12	12	120	26
ASM0713 S12R-3-80				3	13	12	80	13
ASM0713 S12R-3-120				3	13	12	120	13
ASM0714 S14R-3-80				3	14	14	80	30
ASM0714 S14R-3-120				3	14	14	120	30
ASM0714 S14R-3-160				3	14	14	160	30
ASM0715 S14R-4-120				4	15	14	120	15
ASM0715 S14R-4-160				4	15	14	160	15
ASM0716 S16R-4-100				4	16	16	100	35
ASM0716 S16R-4-120				4	16	16	120	35
ASM0716 S16R-4-160				4	16	16	160	35
ASM0717 S16R-4-120				4	17	16	120	17
ASM0717 S16R-4-160				4	17	16	160	17

A

铣刀系列
Milling cutter series

A

铣刀系列
Milling cutter series

BAP300系列锁牙刀头
BAP300 SERIES OF LOCK TOOL HEAD

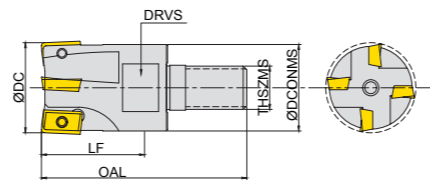

型号 Model	AP1135	适用条件							螺丝 Screw	扳手 Wrench
		刃数	φDc	φDCONMS	LF	OAL	THSZMS	DRVS		
BAP300R 15 2T M6	AP1135	2	15	13	17	32	M06	10	LD35202560 T8-30	T-8
BAP300R 16 2T M8		2	16	15	25	43	M08	12		
BAP300R 20 2T M10		2	20	19	29	49	M10	15		
BAP300R 25 3T M12		3	25	24	35	57	M12	19		
BAP300R 26 3T M12		3	26	24	35	57	M12	19		
BAP300R 32 3T M16		3	32	31	38	63	M16	24		
BAP300R 35 4T M16		4	35	34	38	63	M16	24		

直杆铣刀BAP系列
STRAIGHT BAR MILLER CUTTER BAP SERIES

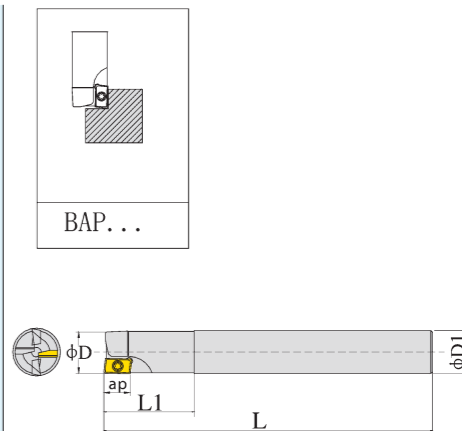

型号 Model	AP1135	适用条件						螺丝 Screw	扳手 Wrench			
		刃数	D	D1	L	L1	ap					
BAP300R 10 1T 10-120	AP1135	1	10	10	120	22	9	LD35202560 T8-30	T-8			
BAP300R 12 1T 12-120		1	12	12	120	26	9					
BAP300R 14 1T 14-120		1	14	14	120	46	9					
BAP300R 14 1T 14-160		1	14	14	160	46	9					
BAP300R 15 2T 15-120		2	15	15	120	20	9					
BAP300R 15 2T 15-160		2	15	15	160	20	9					
BAP300R 15 2T 15-200		2	15	15	200	20	9					
BAP300R 16 2T 16-120		2	16	16	120	35	9					
BAP300R 16 2T 16-150		2	16	16	150	35	9					
BAP300R 16 2T 16-160		2	16	16	160	35	9					
BAP300R 16 2T 16-200		2	16	16	200	35	9					
BAP300R 20 2T 20-120		2	20	20	120	44	9					
BAP300R 20 2T 20-150		2	20	20	150	44	9					
BAP300R 20 2T 20-160		2	20	20	160	44	9					
BAP300R 20 2T 20-200		2	20	20	200	44	9					
BAP300R 25 3T 25-120		3	25	25	120	55	9					
BAP300R 25 3T 25-150		3	25	25	150	55	9					
BAP300R 25 3T 25-160		3	25	25	160	55	9					
BAP300R 25 3T 25-200		3	25	25	200	55	9					
BAP300R 26 3T 26-120		3	26	26	120	57	9					
BAP300R 26 3T 26-150		3	26	26	150	57	9					
BAP300R 26 3T 26-160		3	26	26	160	57	9					
BAP300R 26 3T 26-200		3	26	26	200	57	9					
BAP300R 26 3T 26-250		3	26	26	250	57	9					
BAP300R 32 3T 32-160		3	32	32	160	50	9					
BAP300R 32 3T 32-200		3	32	32	200	50	9					
BAP300R 32 3T 32-250		3	32	32	250	50	9					
BAP400R 25 2T 25-120		AP1604	2	25	25	120	50			14	LD57294010 T15-60	T-15
BAP400R 25 2T 25-150			2	25	25	150	50			14		
BAP400R 25 2T 25-160			2	25	25	160	50			14		
BAP400R 25 2T 25-200			2	25	25	200	50			14		
BAP400R 25 2T 25-250			2	25	25	250	50			14		
BAP400R 26 2T 26-120			2	26	26	120	57			14		
BAP400R 26 2T 26-150			2	26	26	150	57			14		
BAP400R 26 2T 26-160			2	26	26	160	57			14		
BAP400R 26 2T 26-200			2	26	26	200	57			14		
BAP400R 26 2T 26-250			2	26	26	250	57			14		
BAP400R 32 2T 32-160			2	32	32	160	56			14		
BAP400R 32 2T 32-200			2	32	32	200	56			14		
BAP400R 32 2T 32-250			2	32	32	250	56			14		

A

铣刀系列
Milling cutter series

A

铣刀系列
Milling cutter series

变杆铣刀BAP系列
CUTTER BAR MILLER CUTTER BAP SERIES

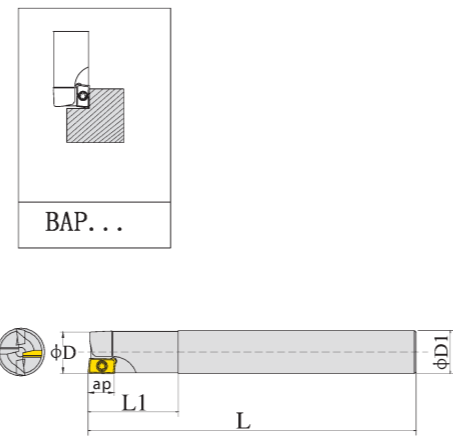

型号 Model		适用条件						螺丝 Screw	扳手 Wrench
		刃数	D	D1	L	L1	ap		
BAP300R 17 2T 16-120	AP1135	2	17	16	120	20	9	LD35202560	T-8
BAP300R 17 2T 16-150		2	17	16	150	20	9		
BAP300R 17 2T 16-160		2	17	16	160	20	9		
BAP300R 17 2T 16-200		2	17	16	200	20	9		
BAP300R 21 2T 20-120		2	21	20	120	21	9		
BAP300R 21 2T 20-150		2	21	20	150	21	9		
BAP300R 21 2T 20-160		2	21	20	160	21	9		
BAP300R 21 2T 20-200		2	21	20	200	21	9		
BAP300R 26 3T 25-120		3	26	25	120	26	9		
BAP300R 26 3T 25-150		3	26	25	150	26	9		
BAP300R 26 3T 25-160		3	26	25	160	26	9		
BAP300R 26 3T 25-200		3	26	25	200	26	9		
BAP300R 26 3T 25-250		3	26	25	250	26	9		
BAP300R 32 3T 25-160		3	32	25	160	44	9		
BAP300R 32 3T 25-200		3	32	25	200	44	9		
BAP300R 32 3T 25-250		3	32	25	250	44	9		
BAP300R 35 3T 32-160		3	35	32	160	44	9		
BAP300R 35 3T 32-200		3	35	32	200	44	9		
BAP300R 35 3T 32-250		3	35	32	250	44	9		
BAP300R 40 3T 32-160		3	40	32	160	44	9		
BAP300R 40 3T 32-200	3	40	32	200	44	9			
BAP300R 40 3T 32-250	3	40	32	250	44	9			
BAP400R 26 2T 25-120	AP1604	2	26	25	120	26	14	LD57294010	T-15
BAP400R 26 2T 25-150		2	26	25	150	26	14		
BAP400R 26 2T 25-160		2	26	25	160	26	14		
BAP400R 26 2T 25-200		2	26	25	200	26	14		
BAP400R 26 2T 25-250		2	26	25	250	26	14		
BAP400R 32 2T 25-160		2	32	25	160	43	14		
BAP400R 32 2T 25-200		2	32	25	200	43	14		
BAP400R 32 2T 25-250		2	32	25	250	43	14		
BAP400R 35 3T 32-160		3	35	32	160	33	14		
BAP400R 35 3T 32-200		3	35	32	200	33	14		
BAP400R 35 3T 32-250		3	35	32	250	33	14		
BAP400R 35 3T 32-300		3	35	32	300	33	14		
BAP400R 40 3T 32-160		3	40	32	160	33	14		
BAP400R 40 3T 32-200		3	40	32	200	33	14		
BAP400R 40 3T 32-250		3	40	32	250	33	14		
BAP400R 40 3T 32-300		3	40	32	300	33	14		

BAP 90° 刀盘系列
BAP 90° CUTTER HEAD SERIES

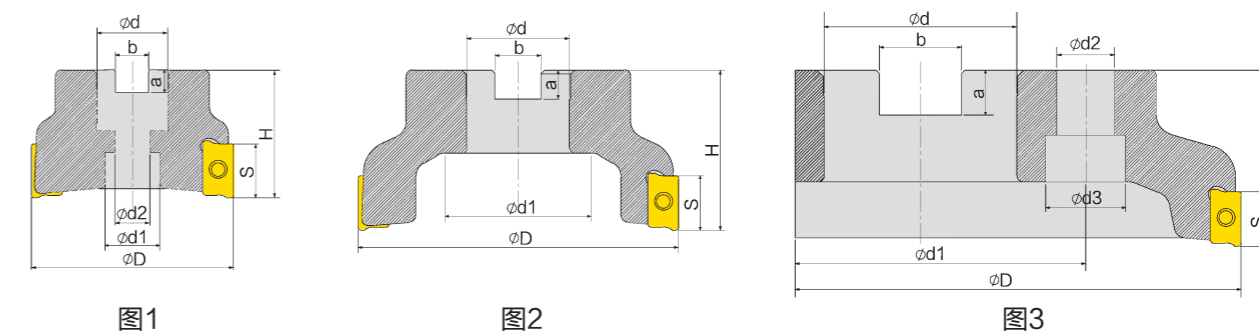
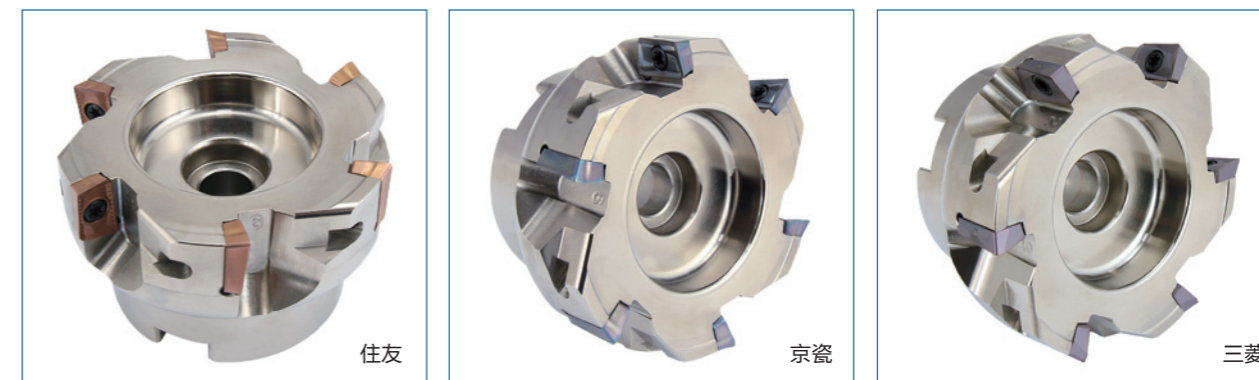

型号 Model		适用条件											螺丝 Screw	扳手 Wrench			
		刃数	ϕD	ϕd	ϕd_1	ϕd_2	ϕd_3	H	S	b	a	形状					
BAP300R 040 5T 16-ZY	AP1135	5	40	16	14	9	-	40	10	8.4	6	图1	LD35202560	T-8			
BAP300R 050 5T 22-ZY		5	50	22	17	11	-	40	10	10.4	7	图1					
BAP300R 050 6T 22-ZY		6	50	22	17	11	-	40	10	10.4	7	图1					
BAP300R 063 6T 22-ZY		6	63	22	17	11	-	40	10	10.4	7	图1					
BAP300R 063 8T 22-ZY		8	63	22	17	11	-	40	10	10.4	7	图1					
BAP300R 080 8T 27-ZY		8	80	27	36.5	13	-	50	10	12.4	7	图1					
BAP300R 080 10T 27-ZY		10	80	27	36.5	13	-	50	10	12.4	7	图1					
BAP400R 050 4T 22-ZY		AP1604	4	50	22	17	11	-	40	14	10.4	7			图1	LD57294010	T-15
BAP400R 050 5T 22-ZY			5	50	22	17	11	-	40	14	10.4	7			图1		
BAP400R 063 4T 22-ZY			4	63	22	17	11	-	40	14	10.4	7			图1		
BAP400R 063 5T 22-ZY	5		63	22	17	11	-	40	14	10.4	7	图1					
BAP400R 080 5T 27-ZY	5		80	27	36.5	13	-	50	14	12.4	7	图1					
BAP400R 080 6T 27-ZY	6		80	27	36.5	13	-	50	14	12.4	7	图1					
BAP400R 100 6T 32-ZY	6		100	32	45.5	-	-	50	14	14.4	9	图2					
BAP400R 100 8T 32-ZY	8		100	32	45.5	-	-	50	14	14.4	9	图2					
BAP400R 125 6T 40-ZY	6		125	40	55.5	-	-	55	14	16.4	9	图2					
BAP400R 125 8T 40-ZY	8		125	40	55.5	-	-	55	14	16.4	9	图2					
BAP400R 160 9T 40-ZY	9		160	40	90.5	-	-	55	14	16.4	9	图2					
BAP400R 160 10T 40-ZY	10		160	40	90.5	-	-	55	14	16.4	9	图2					
BAP400R 200 12T 40-ZY	12		200	60	101.6	18	25	55	14	25.7	14	图3					
BAP400R 250 14T 40-ZY	14		250	60	101.6	18	25	55	14	25.7	14	图3					

A

铣刀系列
Milling cutter series

A

铣刀系列
Milling cutter series

KAP 75° 刀盘系列
KAP 75° CUTTER HEAD SERIES

BAP 90° 刀盘系列
BAP 90° CUTTER HEAD SERIES



图1

图2

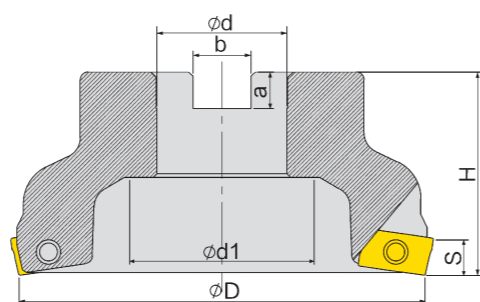
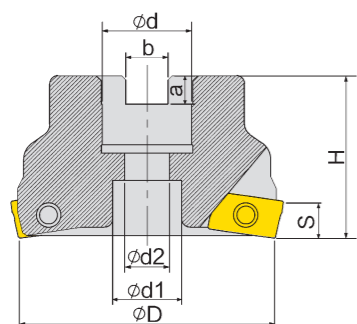
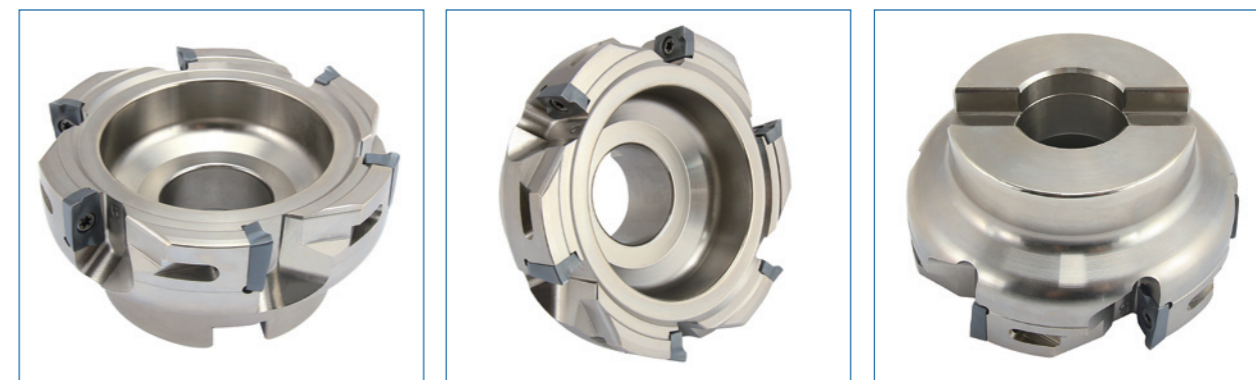

图1

图2

图3

型号 Model		适用条件										螺丝 Screw	扳手 Wrench
		刃数	ϕD	ϕd	$\phi d1$	$\phi d2$	H	S	b	a	形状		
KAP300R 040 5T 16	AP1135	5	40	16	14	9	40	10	8.4	6	图1	LD35202560	T-8
KAP300R 050 5T 22		5	50	22	17	11	40	10	10.4	7	图1		
KAP300R 050 6T 22		6	50	22	17	11	40	10	10.4	7	图1		
KAP300R 063 6T 22		6	63	22	17	11	40	10	10.4	7	图1		
KAP300R 063 8T 22		8	63	22	17	11	40	10	10.4	7	图1		
KAP300R 080 8T 27		8	80	27	36.5	13	50	10	12.4	7	图1		
KAP300R 080 10T 27		10	80	27	36.5	13	50	10	12.4	7	图1		
KAP400R 050 4T 22		AP1604	4	50	22	17	11	40	7.5	10.4	7		
KAP400R 063 4T 22	4		63	22	17	11	40	7.5	10.4	7	图1		
KAP400R 080 6T 27	6		80	27	34.5	13	50	7.5	12.4	7	图1		
KAP400R 100 6T 32	6		100	32	48	-	50	7.5	14.4	9	图2		
KAP400R 125 8T 40	8		125	40	60	-	55	7.5	16.4	9	图2		
KAP400R 160 9T 40	9		160	40	99	-	55	7.5	16.4	9	图2		

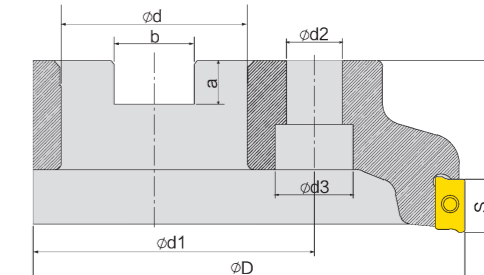
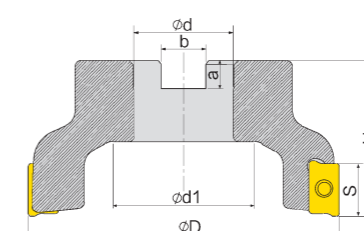
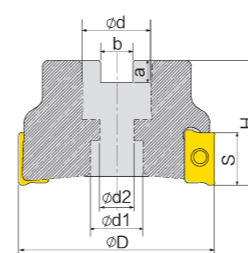
型号 Model		适用条件										螺丝 Screw	扳手 Wrench	
		刃数	ϕD	ϕd	$\phi d1$	$\phi d2$	$\phi d3$	H	S	b	a			形状
BAP400R 050 4T 22-DL	AP1604D 杜龙	4	50	22	17	11	-	40	14	10.4	7	图1	LD50214010	T-15
BAP400R 050 5T 22-DL		5	50	22	17	11	-	40	14	10.4	7	图1		
BAP400R 063 4T 22-DL		4	63	22	17	11	-	40	14	10.4	7	图1		
BAP400R 063 5T 22-DL		5	63	22	17	11	-	40	14	10.4	7	图1		
BAP400R 080 5T 27-DL		5	80	27	36.5	13	-	50	14	12.4	7	图1		
BAP400R 080 6T 27-DL		6	80	27	36.5	13	-	50	14	12.4	7	图1		
BAP400R 100 6T 32-DL		6	100	32	45.5	-	-	50	14	14.4	9	图2		
BAP400R 100 8T 32-DL		8	100	32	45.5	-	-	50	14	14.4	9	图2		
BAP400R 125 6T 40-DL		6	125	40	55.5	-	-	55	14	16.4	9	图2		
BAP400R 125 8T 40-DL		8	125	40	55.5	-	-	55	14	16.4	9	图2		
BAP400R 160 9T 40-DL		9	160	40	90.5	-	-	55	14	16.4	9	图2		
BAP400R 160 10T 40-DL		10	160	40	90.5	-	-	55	14	16.4	9	图2		
BAP400R 200 12T 40-DL		12	200	60	101.6	18	25	55	14	25.7	14	图3		
BAP400R 250 14T 40-DL		14	250	60	101.6	18	25	55	14	25.7	14	图3		

MEC系列铣刀杆
MEC SERIES MILLING CUTTER BAR

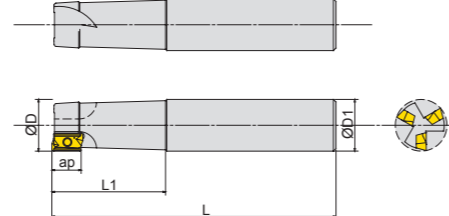
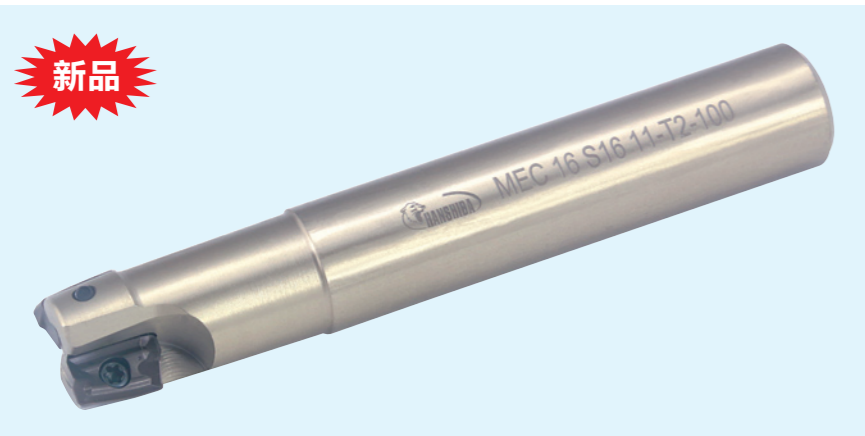

型号 Model		适用条件						螺丝 Screw	扳手 Wrench
		刃数	ϕD	$\phi D1$	L	L1	a_p		
MEC 10-S10-11-T1-80	BDMT1103 京瓷	1	10	10	80	22	10	LD35212550 T8-30	T-8
MEC 12-S12-11-T1-80		1	12	12	80	26	10		
MEC 14-S16-11-T1-100		1	14	16	100	30	10		
MEC 16-S16-11-T2-100		2	16	16	100	35	10		
MEC 20-S20-11-T3-110		3	20	20	110	44	10		
MEC 25-S25-11-T3-120		3	25	25	120	55	10		
MEC 25-S25-11-T4-120		4	25	25	120	55	10		
MEC 32-S32-11-T4-150		4	32	32	150	70	10		
MEC 32-S32-11-T5-150	5	32	32	150	70	10	LD57294010 T15-60	T15	
MEC 25-S25-17-T2-160	2	25	25	160	55	15.7			
MEC 32-S32-17-T3-150	3	32	32	160	70	15.7			

MEC 90° 刀盘系列
MEC 90° CUTTER HEAD SERIES



图1



图2

型号 Model		适用条件										螺丝 Screw	扳手 Wrench
		刃数	ϕD	ϕd	$\phi d1$	$\phi d2$	H	S	b	a	形状		
MEC 050R 17-4T	BDMT1704 京瓷	4	50	22	17	11	40	15.7	10.4	7	图1	LD57294010 T15-60	T-15
MEC 063R 17-4T		4	63	22	17	11	40	15.7	10.4	7	图1		
MEC 080R 17-5T		5	80	27	36.5	13	50	15.7	12.4	7	图1		
MEC 080R 17-6T		6	80	27	36.5	13	50	15.7	12.4	7	图1		
MEC 100R 17-6T		6	100	32	45.5	-	50	15.7	14.4	9	图2		
MEC 125R 17-8T		8	125	40	55.5	-	55	15.7	16.4	9	图2		

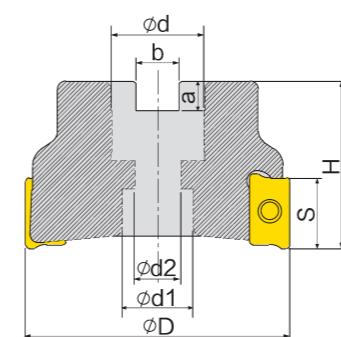
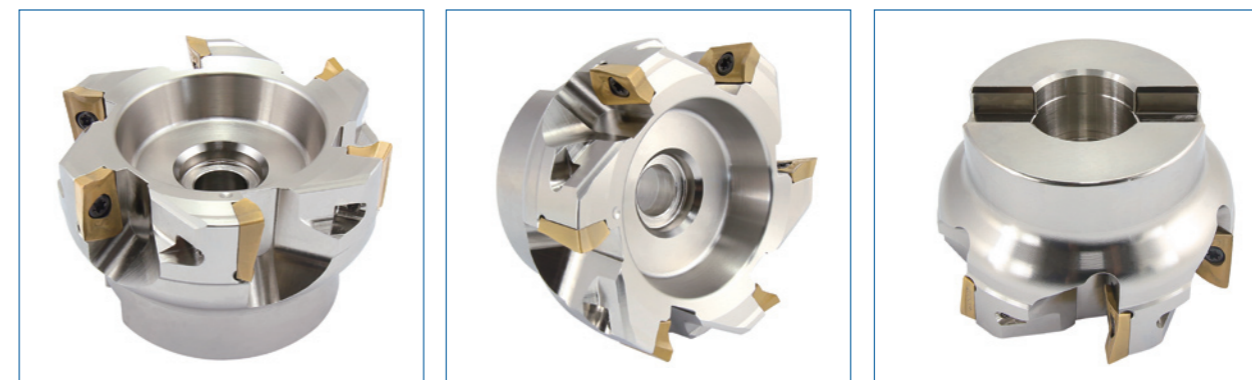
注：从160-400可以选用百变魔术刀盘

R390 90° 刀盘系列
R390 90° CUTTER HEAD SERIES

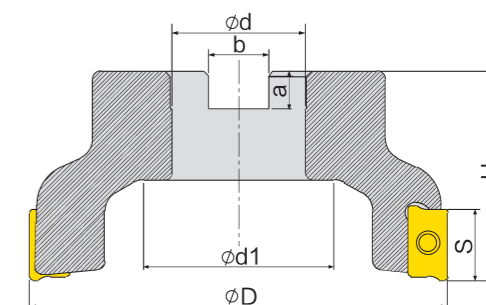

图1

图2

图3

型号 Model		适用条件										螺丝 Screw	扳手 Wrench	
		刃数	φD	φd	φd1	φd2	φd3	H	S	b	a			形状
R390 040 4T 16-11	R390-11 山特维克	4	40	16	14	9	-	40	10	8.4	6	图1	LD35212550	T-8
R390 050 5T 22-11		5	50	22	17	11	-	40	10	10.4	7	图1		
R390 063 5T 22-11		5	63	22	17	11	-	40	10	10.4	7	图1		
R390 080 6T 27-11		6	80	27	36.5	13	-	50	10	12.4	7	图1		
R390 050 4T 22-17	R390-17 山特维克	4	50	22	17	11	-	40	15.7	10.4	7	图1	LD53273580	T-15
R390 050 5T 22-17		5	50	22	17	11	-	40	15.7	10.4	7	图1		
R390 063 4T 22-17		4	63	22	17	11	-	40	15.7	10.4	7	图1		
R390 063 5T 22-17		5	63	22	17	11	-	40	15.7	10.4	7	图1		
R390 080 5T 27-17		5	80	27	36.5	13	-	50	15.7	12.4	7	图1		
R390 080 6T 27-17		6	80	27	36.5	13	-	50	15.7	12.4	7	图1		
R390 100 6T 32-17		6	100	32	45.5	-	-	50	15.7	14.4	9	图2		
R390 100 8T 32-17		8	100	32	45.5	-	-	50	15.7	14.4	9	图2		
R390 125 8T 40-17		8	125	40	55.5	-	-	55	15.7	16.4	9	图2		
R390 160 10T 40-17		10	160	40	90.5	-	-	55	15.7	16.4	9	图2		
R390 200 12T 60-17	12	200	60	101.6	18	25	55	15.7	25.7	14	图3			
R390 250 14T 60-17	14	250	60	101.6	18	25	55	15.7	25.7	14	图3			

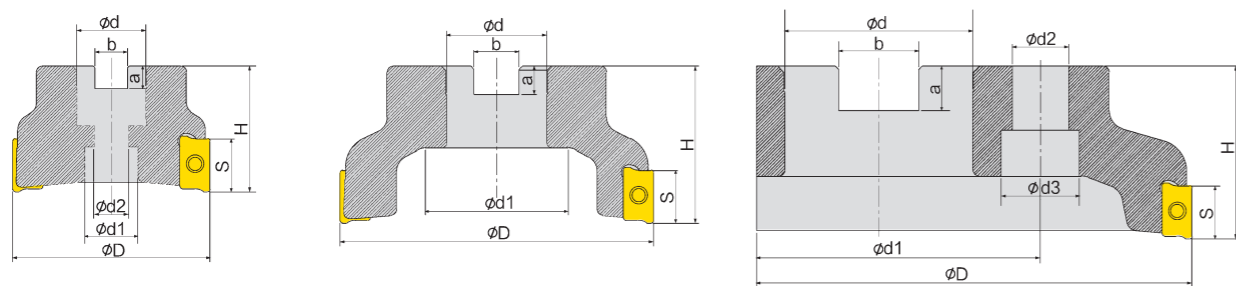
注：从315-400可以选用百变魔术刀盘

WEX 90° 刀盘系列
WEX 90° CUTTER HEAD SERIES



图1

图2

型号 Model		适用条件										螺丝 Screw	扳手 Wrench
		刃数	φD	φd	φd1	φd2	H	S	b	a	形状		
WEX 3050R-4T	AXMT1705 住友	4	50	22	17	11	40	15.7	10.4	7	图1	LD57294010	T-15
WEX 3063R-5T		4	63	22	17	11	40	15.7	10.4	7	图1		
WEX 3080R-5T		5	80	27	36.5	13	50	15.7	12.4	7	图1		
WEX 3080R-6T		6	80	27	36.5	13	50	15.7	12.4	7	图1		
WEX 3100R-8T		6	100	32	45.5	-	50	15.7	14.4	9	图2		
WEX 3125R-9T		8	125	40	55.5	-	55	15.7	16.4	9	图2		

注：从160-400可以选用百变魔术刀盘

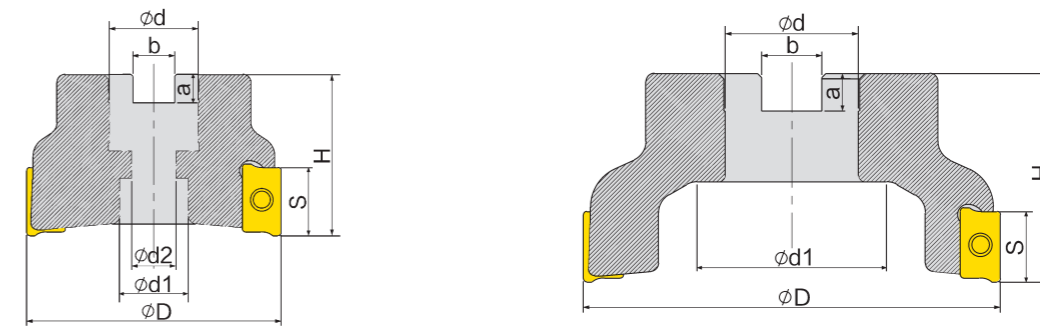
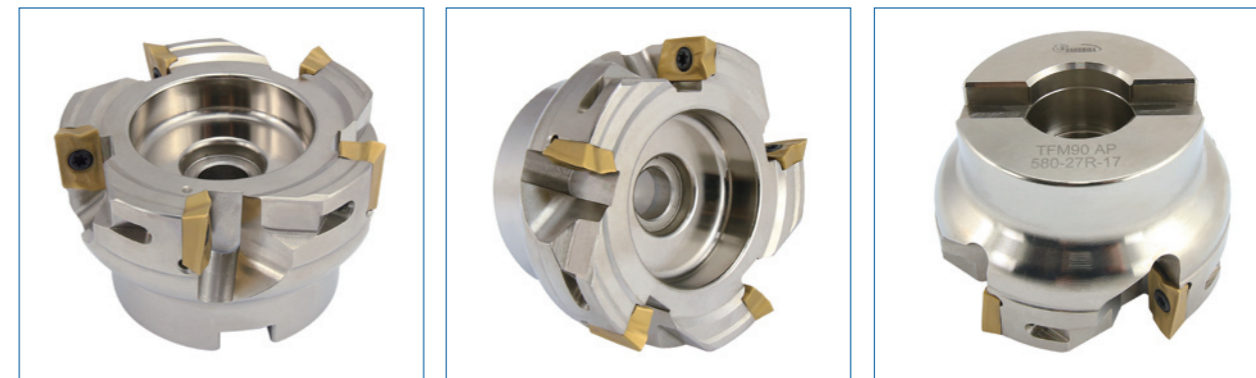
TPS 90° 刀盘系列
TPS 90° CUTTER HEAD SERIES



图1



图2

型号 Model		适用条件									形状	螺丝 Screw	扳手 Wrench
		刃数	ϕD	ϕd	$\phi d1$	$\phi d2$	H	S	b	a			
TPS 17050RB-4T	AS..T 1705.. 东芝	4	50	22	17	11	40	15.7	10.4	7	图1	LD57294010	T-15
TPS 17063RB-4T		4	63	22	17	11	40	15.7	10.4	7	图1		
TPS 17080RB-5T		5	80	27	36.5	13	50	15.7	12.4	7	图1		
TPS 17080RB-6T		6	80	27	36.5	13	50	15.7	12.4	7	图1		
TPS 17100RB-6T		6	100	32	45.5	-	50	15.7	14.4	9	图2		
TPS 17125RB-8T		8	125	40	55.5	-	55	15.7	16.4	9	图2		

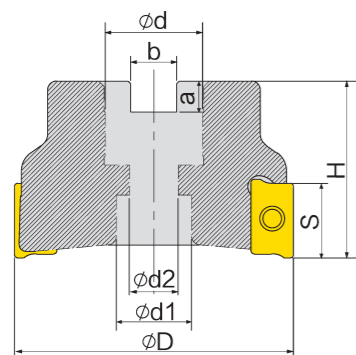
注：从160-400可以选用百变魔术刀盘

TFM 90° 刀盘系列
TFM 90° CUTTER HEAD SERIES

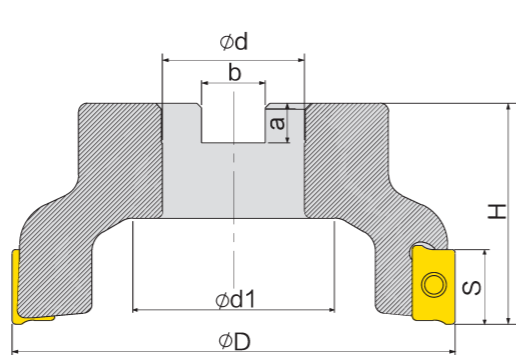

图1



图2

型号 Model		适用条件									形状	螺丝 Screw	扳手 Wrench
		刃数	ϕD	ϕd	$\phi d1$	$\phi d2$	H	S	b	a			
TFM90AP 450-22R-17	APKT1705 特固克	4	50	22	17	11	40	15.7	10.4	7	图1	LD57294010	T-15
TFM90AP 463-22R-17		4	63	22	17	11	40	15.7	10.4	7	图1		
TFM90AP 563-22R-17		5	63	22	17	11	40	15.7	10.4	7	图1		
TFM90AP 580-27R-17		5	80	27	36.5	13	50	15.7	12.4	7	图1		
TFM90AP 680-27R-17		6	80	27	36.5	13	50	15.7	12.4	7	图1		
TFM90AP 6100-32R-17		6	100	32	45.5	-	50	15.7	14.4	9	图2		
TFM90AP 8125-40R-17		8	125	40	55.5	-	55	15.7	16.4	9	图2		

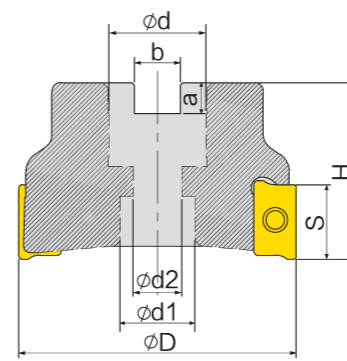
注：从160-400可以选用百变魔术刀盘

APX 90° 刀盘系列
APX 90° CUTTER HEAD SERIES

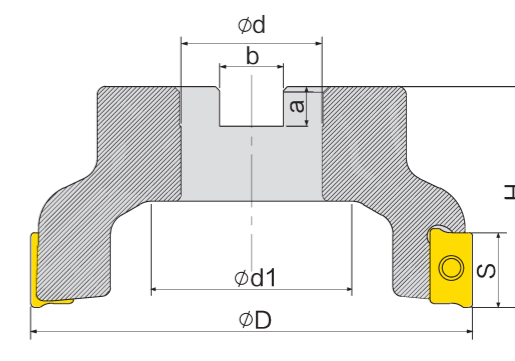

图1



图2

型号 Model		适用条件									螺丝 Screw	扳手 Wrench	
		刃数	ϕD	ϕd	$\phi d1$	$\phi d2$	H	S	b	a			形状
APX4000-050A04RA	AOMT 1848 三菱	4	50	22	17	11	40	15.7	10.4	7	图1	LD57294010 T15-60	T-15
APX4000-063A04RA		4	63	22	17	11	40	15.7	10.4	7	图1		
APX4000-080A05RA		5	80	27	36.5	13	50	15.7	12.4	7	图1		
APX4000-080A06RA		6	80	27	36.5	13	50	15.7	12.4	7	图1		
APX4000-100A06RA		6	100	32	45.5	-	50	15.7	14.4	9	图2		
APX4000-125A08RA		8	125	40	55.5	-	55	15.7	16.4	9	图2		

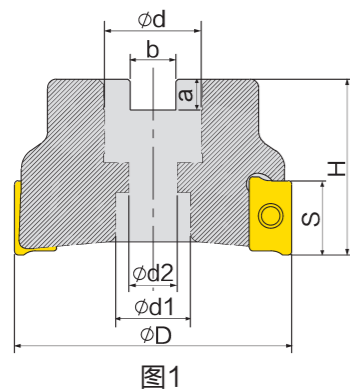
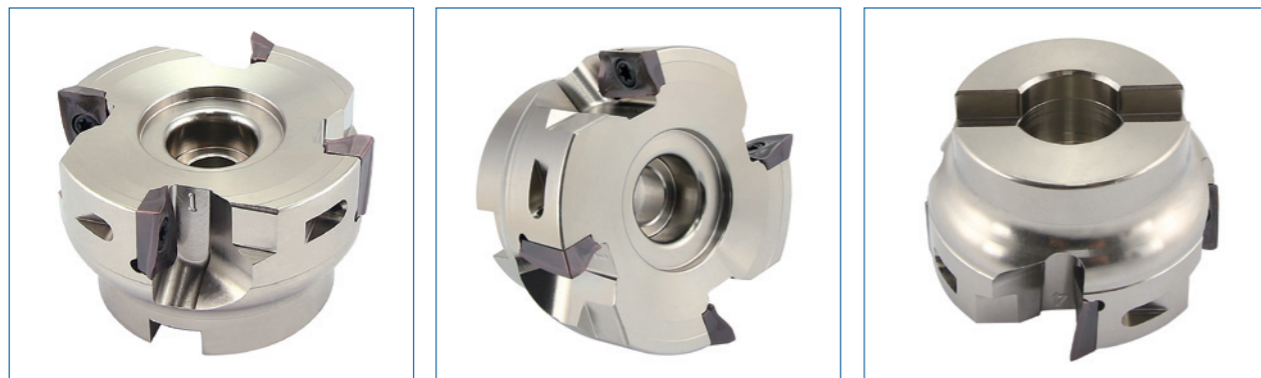
注：从160-400可以选用百变魔术刀盘

MFWN 04 05系列锁牙刀头
MFWN 04 05 SERIES OF LOCK TOOL HEAD

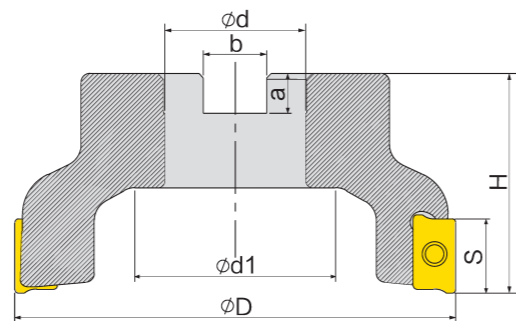
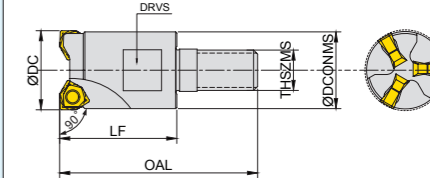
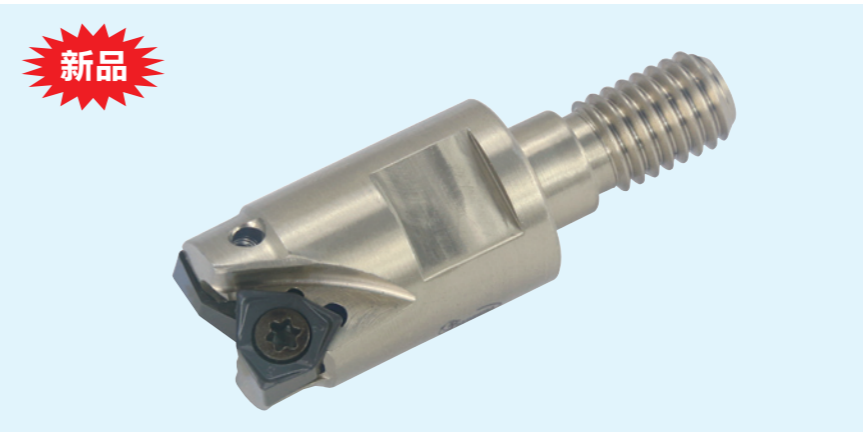

型号 Model		适用条件							螺丝 Screw	扳手 Wrench
		刃数	ϕDc	$\phi DCNNMS$	LF	OAL	THSZMS	DRVS		
MFWN90-16-M8-04-2T	WN0403	2	16	15	25	43	M08	12	LD40292560 T8-37	T-8
MFWN90-17-M8-04-2T		2	17	15	25	43	M08	12		
MFWN90-20-M10-04-3T		3	20	19	29	49	M10	15		
MFWN90-21-M10-04-3T		3	21	19	29	49	M10	15		
MFWN90-25-M12-04-3T		3	25	24	35	57	M12	19		
MFWN90-26-M12-04-3T		3	26	24	35	57	M12	19		
MFWN90-32-M16-04-4T		4	32	31	38	63	M16	24		
MFWN90-33-M16-04-4T		4	33	31	38	63	M16	24		
MFWN90-35-M16-04-5T		5	35	31	38	63	M16	24		
MFWN90-25-M12-05-2T		WN0504	2	25	24	35	57	M12		
MFWN90-26-M12-05-2T	2		26	24	35	57	M12	19		
MFWN90-32-M16-05-3T	3		32	31	38	63	M16	24		
MFWN90-33-M16-05-3T	3		33	31	38	63	M16	24		
MFWN90-35-M16-05-4T	4		35	31	38	63	M16	24		

MFWN04系列扩铣复合专用刀杆
MFWN04 SERIES EXPANSION MILLING COMPOSITE SPECIAL TOOL HOLDER

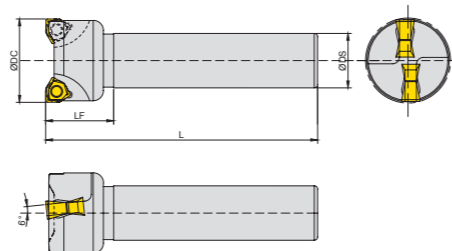

型号 Model		适用条件					螺丝 Screw	扳手 Wrench
		刃数	φDC	φDS	L	LF		
MFWN90 16-S16-80-04-2T	WN0403	2	16	16	80	20	LD40292560 T8-37	T-8
MFWN90 17-S16-80-04-2T		2	17	16	80	20		
MFWN90 18-S16-80-04-2T		2	18	16	80	20		
MFWN90 19-S16-80-04-2T		2	19	16	80	20		
MFWN90 20-S16-80-04-3T		3	20	16	80	20		
MFWN90 21-S16-80-04-3T		3	21	16	80	20		
MFWN90 22-S16-80-04-3T		3	22	16	80	20		
MFWN90 23-S16-80-04-3T		3	23	16	80	20		
MFWN90 24-S16-80-04-3T		3	24	16	80	20		
MFWN90 25-S16-80-04-3T		3	25	16	80	20		
MFWN90 26-S16-80-04-3T		3	26	16	80	20		
MFWN90 28-S16-80-04-4T		4	28	16	80	20		
MFWN90 30-S16-80-04-4T		4	30	16	80	20		
MFWN90 32-S16-80-04-4T		4	32	16	80	20		
MFWN90 35-S16-80-04-5T		5	35	16	80	20		
MFWN90 40-S16-80-04-5T		5	40	16	80	20		

MFWN04系列铣刀杆
MFWN04 SERIES MILLING CUTTER BAR

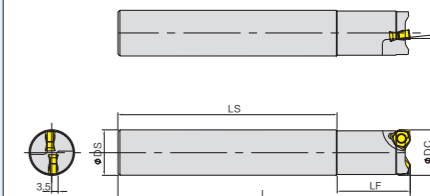
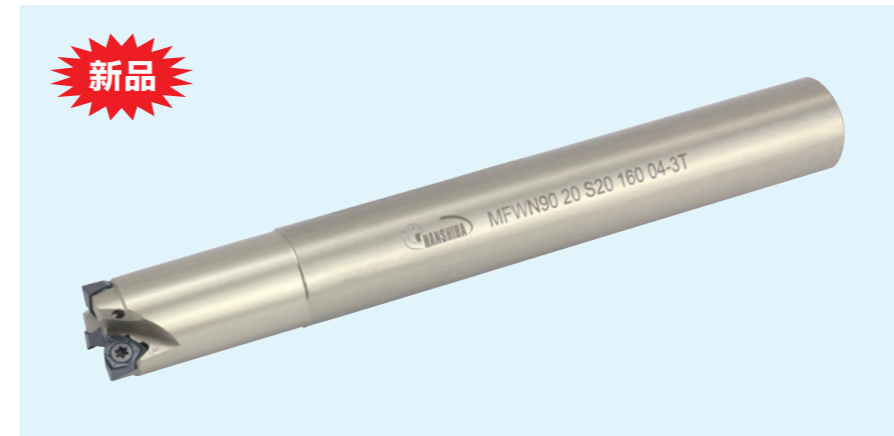

型号 Model		适用条件					螺丝 Screw	扳手 Wrench
		刃数	φDC	φDS	L	LF		
MFWN90-16-S16-120-04-2T	WN0403	2	16	16	120	35	LD40292560 T8-37	T-8
MFWN90-16-S16-160-04-2T		2	16	16	160	35		
MFWN90-16-S16-200-04-2T		2	16	16	200	35		
MFWN90-17-S16-150-04-2T		2	17	16	150	17		
MFWN90-17-S16-160-04-2T		2	17	16	160	17		
MFWN90-17-S16-200-04-2T		2	17	16	200	22		
MFWN90-20-S20-120-04-2T		3	20	20	120	44		
MFWN90-20-S20-160-04-3T		3	20	20	160	44		
MFWN90-20-S20-200-04-3T		3	20	20	200	44		
MFWN90-21-S20-120-04-3T		3	21	20	120	21		
MFWN90-21-S20-160-04-3T		3	21	20	160	21		
MFWN90-21-S20-200-04-3T		3	21	20	200	22		
MFWN90-25-S25-120-04-3T		3	25	25	120	55		
MFWN90-25-S25-150-04-3T		3	25	25	150	55		
MFWN90-25-S25-160-04-3T		3	25	25	160	55		
MFWN90-25-S25-200-04-3T		3	25	25	200	55		
MFWN90-26-S25-120-04-3T		3	26	25	120	26		
MFWN90-26-S25-160-04-3T		3	26	25	160	26		
MFWN90-26-S25-200-04-3T		3	26	25	200	26		
MFWN90-32-S32-120-04-4T		4	32	32	120	64		
MFWN90-32-S32-160-04-4T		4	32	32	160	70		
MFWN90-32-S32-200-04-4T		4	32	32	200	70		
MFWN90-33-S32-160-04-4T		4	33	32	160	33		
MFWN90-33-S32-200-04-4T		4	33	32	200	33		
MFWN90-35-S32-160-04-5T		5	35	32	160	35		
MFWN90-35-S32-200-04-5T		5	35	32	200	35		

MFWN05系列铣刀杆
MFWN05 SERIES MILLING CUTTER BAR

新品

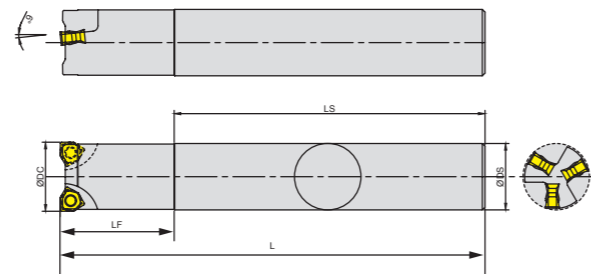

型号 Model		适用条件						螺丝 Screw	扳手 Wrench
		刃数	φDC	φDS	L	LF	LS		
MFWN90 25-S25-120-05-2T	WN0504 (京瓷)	2	25	25	120	55	65	LD40303064 T8-40	
MFWN90 25-S25-160-05-2T		2	25	25	160	55	105		
MFWN90 26-S25-120-05-2T		2	26	25	120	26	94		
MFWN90 26-S25-160-05-2T		2	26	25	160	26	134		
MFWN90 26-S25-200-05-2T		2	26	25	200	26	174		
MFWN90 32-S32-160-05-3T		3	32	32	160	70	90		
MFWN90 32-S32-200-05-3T		3	32	32	200	70	130		
MFWN90 33-S32-160-05-3T		3	33	32	160	33	127		
MFWN90 33-S32-200-05-3T		3	33	32	200	33	167		

MFWN06系列铣刀杆
MFWN06 SERIES MILLING CUTTER BAR

新品

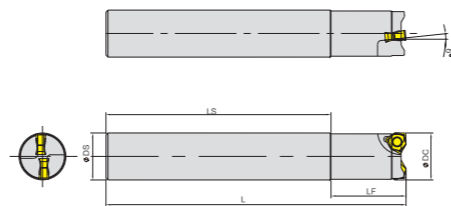

型号 Model		适用条件				螺丝 Screw	扳手 Wrench
		φDC	φDS	L	LF		
MFWN90 25-S25-120-06-2T	WN0604	25	25	120	55	LD50203510 T15-60	T15
MFWN90 25-S25-160-06-2T		25	25	160	55		
MFWN90 25-S25-200-06-2T		25	25	200	55		
MFWN90 26-S25-160-06-2T		26	25	160	26		
MFWN90 26-S25-200-06-2T		26	25	200	26		
MFWN90 32-S32-160-06-3T		32	32	160	70		
MFWN90 32-S32-200-06-3T		32	32	200	70		
MFWN90 33-S32-160-06-3T		33	32	160	33		
MFWN90 33-S32-200-06-3T		33	32	200	33		

MFWN90°刀盘系列
MFWN90° CUTTER HEAD SERIES

新品

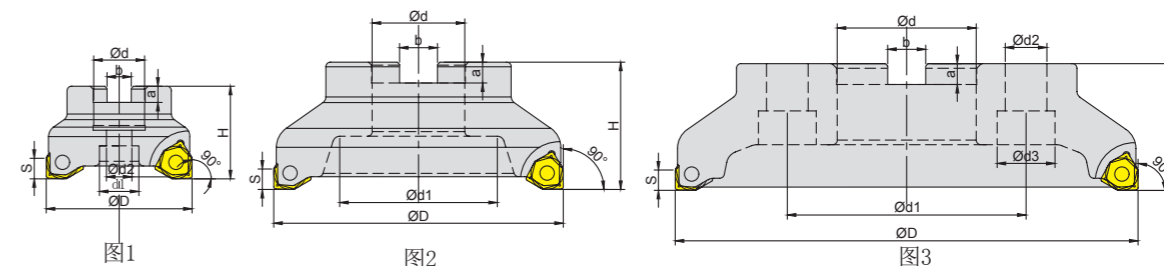
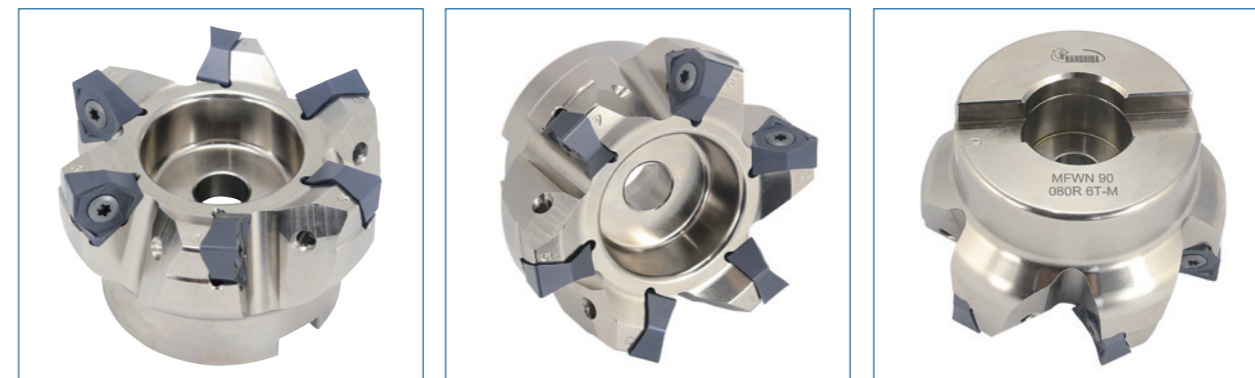

型号 Model		适用条件											螺丝 Screw	扳手 Wrench
		刃数	φD	φd	φd1	φd2	φd3	H	S	b	a	形状		
MFWN90040R-04-4T-M	WN0403	4	40	16	14	9	-	40	4	8.4	7	图1	LD40292560 T8-37	T-8
MFWN90050R-04-5T-M		5	50	22	17	11	-	40	4	10.4	7	图1		
MFWN90063R-04-6T-M		6	63	22	17	11	-	40	4	10.4	7	图1		
MFWN90080R-04-8T-M		8	80	27	34	13	-	50	4	12.4	7	图1		
MFWN90040R-05-4T-M	WN0504 (京瓷)	4	40	16	14	9	-	40	5	8.4	7	图1	LD40303064 T8-40	T-8
MFWN90050R-05-5T-M		5	50	22	17	11	-	40	5	10.4	7	图1		
MFWN90063R-05-6T-M		6	63	22	17	11	-	40	5	10.4	7	图1		
MFWN90080R-05-8T-M	WN0604	8	80	27	34	13	-	50	5	12.4	7	图1	LD50203510 T15-60	T-15
MFWN90040R-06-5T-M		5	40	16	14	9	-	40	6	8.4	7	图1		
MFWN90050R-06-5T-M		5	50	22	17	11	-	40	6	10.4	7	图1		
MFWN90063R-06-6T-M		6	63	22	17	11	-	40	6	10.4	7	图1		
MFWN90080R-06-8T-M	WN0806 (京瓷)	8	80	27	34	13	-	50	6	12.4	7	图1	LD72255012 T15-80	T-15
MFWN90050R-08-4T-M		4	50	22	17	11	-	40	8	10.4	7	图1		
MFWN90063R-08-5T-M		5	63	22	17	11	-	40	8	10.4	7	图1		
MFWN90080R-08-6T-M		6	80	27	34	13	-	50	8	12.4	7	图1		
MFWN900100R-08-7T-M		7	100	32	42	17	-	50	8	14.4	9	图1		
MFWN900125R-08-8T-M		8	125	40	-	-	-	55	8	16.4	9	图2		
MFWN900160R-08-10T-M		10	160	40	-	-	-	55	8	16.4	9	图2		
MFWN900200R-08-12T-M		12	200	60	101.6	18	26	55	8	25.4	9	图3		
MFWN900250R-08-14T-M	14	250	60	101.6	18	26	55	8	25.4	9	图3			

WN 90° 刀盘系列
WN 90° CUTTER HEAD SERIES



图1

图2

图3

型号 Model		适用条件										螺丝 Screw	扳手 Wrench	
		刃数	φD	φd	φd1	φd2	φd3	H	S	b	a			形状
MEE190 050R05A22	WN 0806	5	50	22	17	11	-	40	8	10.4	7	图1	LD60254011 T15-60	T-15
MEE190 063R06A22		6	63	22	17	11	-	40	8	10.4	7	图1		
MEE190 080R07A27		7	80	27	32	13	-	50	8	12.4	7	图1		
MEE190 100R08A32		8	100	32	40	-	-	50	8	14.4	9	图2		
MEE190 125R10A40		10	125	40	50	-	-	55	8	16.4	9	图2		
MEE190 160R12A40		12	160	40	87	-	-	55	8	16.4	9	图2		
MEE190 200R14A60		14	200	60	101.6	18	25	55	8	25.7	14	图3		
MEE190 250R16A60		16	250	60	101.6	18	25	55	8	25.7	14	图3		

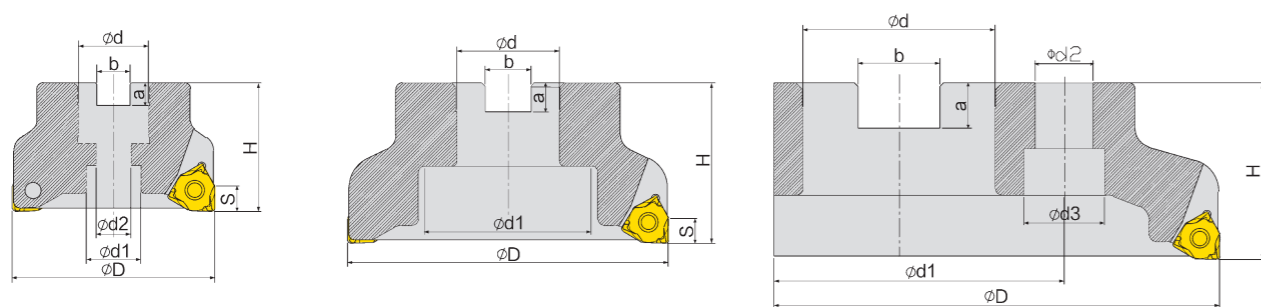
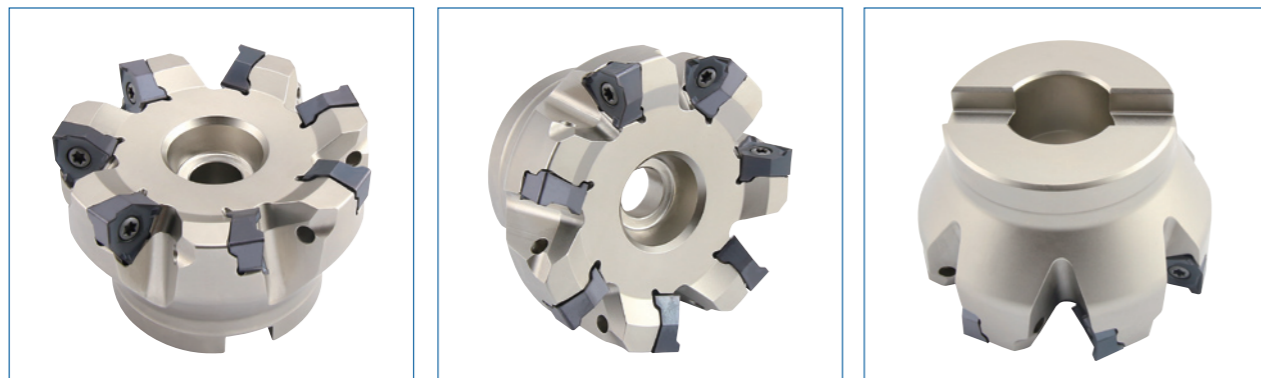
型号 Model		适用条件										螺丝 Screw	扳手 Wrench	
		刃数	φD	φd	φd1	φd2	φd3	H	S	b	a			形状
MEE190 050R05A22-YZ	WN 0806	5	50	22	17	11	-	40	8	10.4	7	图1	LD60254011 T15-60	T-15
MEE190 063R06A22-YZ		6	63	22	17	11	-	40	8	10.4	7	图1		
MEE190 080R07A27-YZ		7	80	27	32	13	-	50	8	12.4	7	图1		
MEE190 100R08A32-YZ		8	100	32	40	-	-	50	8	14.4	9	图2		
MEE190 125R10A40-YZ		10	125	40	50	-	-	55	8	16.4	9	图2		
MEE190 160R12A40-YZ		12	160	40	87	-	-	55	8	16.4	9	图2		
MEE190 200R14A60-YZ		14	200	60	101.6	18	25	55	8	25.7	14	图3		
MEE190 250R16A60-YZ		16	250	60	101.6	18	25	55	8	25.7	14	图3		

注：从315-400可以选用百变魔术刀盘

A

铣刀系列
Milling cutter series

4N TE-90系列锁牙刀头
4N TE-90 SERIES OF LOCK TOOL HEAD

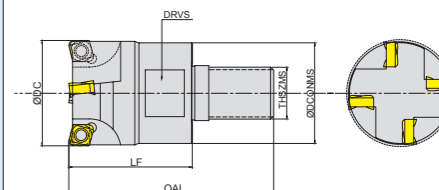

型号 Model		适用条件							螺丝 Screw	扳手 Wrench
		刃数	φDc	φDCONMS	LF	OAL	THSZMS	DRVS		
4N TE90-108-M04-04	4NKT0402	1	8	7.8	17	28	M04	7	LD25251840 T6-20	T-6
4N TE90-109-M04-04		1	9	7.8	17	28	M04	7		
4N TE90-210-M05-04		2	10	9	17	29	M05	7		
4N TE90-211-M05-04		2	11	9	17	29	M05	7		
4N TE90-312-M06-04		3	12	11	17	32	M06	9		
4N TE90-313-M06-04		3	13	11	17	32	M06	9		
4N TE90-414-M06-04		4	14	13	17	32	M06	10		
4N TE90-415-M06-04		4	15	13	17	32	M06	10		
4N TE90-416-M08-04		4	16	15	25	43	M08	12		
4N TE90-417-M08-04		4	17	15	25	43	M08	12		
4N TE90-216-M08-06		2	16	15	25	43	M08	12		
4N TE90-217-M08-06		2	17	15	25	43	M08	12		
4N TE90-320-M10-06		2	20	19	29	49	M10	15		
4N TE90-321-M10-06		2	21	19	29	49	M10	15		
4N TE90-425-M12-06	3	25	24	35	57	M12	19			
4N TE90-426-M12-06	3	26	24	35	57	M12	19			
4N TE90-532-M16-06	4	32	31	38	63	M16	24			
4N TE90-533-M16-06	4	33	31	38	63	M16	24			
								LD40303064 T8-40	T-8	

A

铣刀系列
Milling cutter series

4N TE90系列铣刀杆
4N TE90 SERIES MILLING CUTTER BAR

4N TE90系列铣刀杆
4N TE90 SERIES MILLING CUTTER BAR

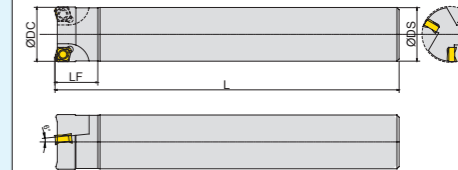
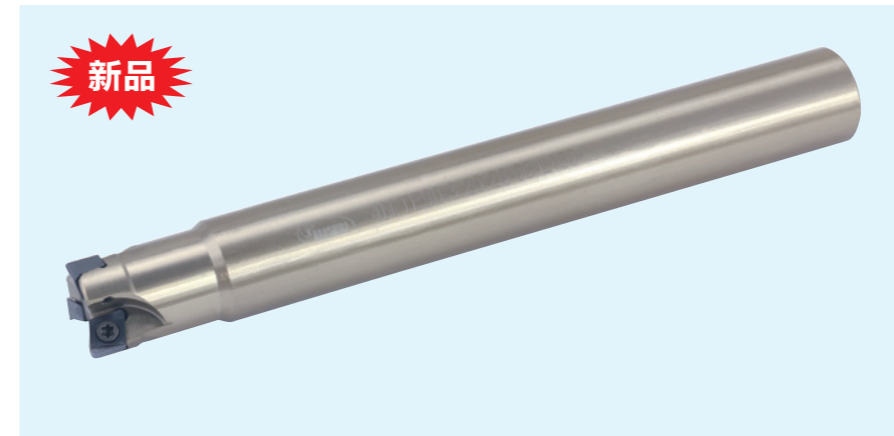
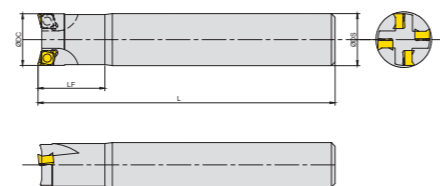
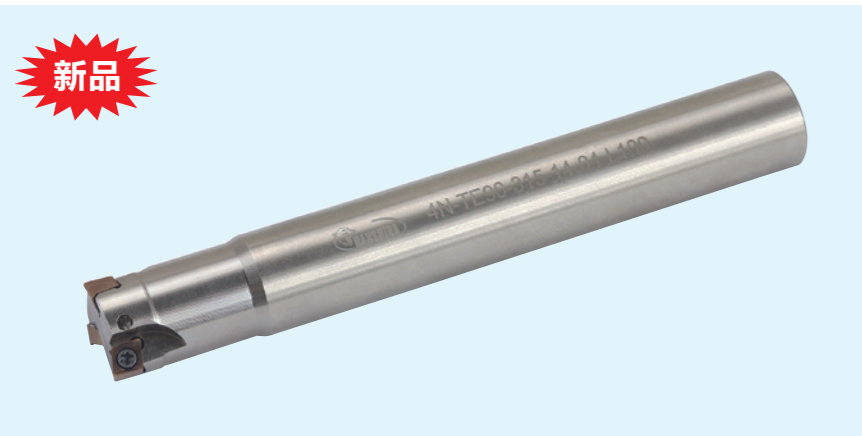

型号 Model		适用条件					螺丝 Screw	扳手 Wrench
		刃数	φDC	φDS	L	LF		
4N TE90-107-10-04-L80	4NKT0402	1	7	10	80	15	LD25251840 T6-20	T-6
4N TE90-107-10-04-L100		1	7	10	100	15		
4N TE90-107-10-04-L120		1	7	10	120	15		
4N TE90-108-10-04-L80		1	8	10	80	17		
4N TE90-108-10-04-L100		1	8	10	100	17		
4N TE90-108-10-04-L120		1	8	10	120	17		
4N TE90-109-10-04-L80		1	9	10	80	19		
4N TE90-109-10-04-L100		1	9	10	100	19		
4N TE90-109-10-04-L120		1	9	10	120	19		
4N TE90-210-10-04-L80		2	10	10	80	22		
4N TE90-210-10-04-L100		2	10	10	100	22		
4N TE90-210-10-04-L120		2	10	10	120	22		
4N TE90-211-10-04-L80		2	11	10	80	11		
4N TE90-211-10-04-L100		2	11	10	100	11		
4N TE90-211-10-04-L120		2	11	10	120	11		
4N TE90-312-12-04-L80		3	12	12	80	26		
4N TE90-312-12-04-L100		3	12	12	100	26		
4N TE90-312-12-04-L120		3	12	12	120	26		
4N TE90-313-12-04-L80		3	13	12	80	13		
4N TE90-313-12-04-L100		3	13	12	100	13		
4N TE90-313-12-04-L120		3	13	12	120	13		
4N TE90-314-14-04-L100		3	14	14	100	30		
4N TE90-314-14-04-L120		3	14	14	120	30		
4N TE90-314-14-04-L160		3	14	14	160	30		
4N TE90-315-14-04-L100		3	15	14	00	15		
4N TE90-315-14-04-L120		3	15	14	120	15		
4N TE90-315-14-04-L160		3	15	14	160	15		
4N TE90-416-16-04-L120		4	16	16	120	35		
4N TE90-416-16-04-L160		4	16	16	160	35		
4N TE90-416-16-04-L200		4	16	16	200	35		
4N TE90-417-16-04-L120		4	17	16	120	17		
4N TE90-417-16-04-L160		4	17	16	160	17		
4N TE90-417-16-04-L200		4	17	16	200	22		

型号 Model		适用条件					螺丝 Screw	扳手 Wrench
		刃数	φDC	φDS	L	LF		
4N TE90-110-10-06-L80	4NKT0603	1	10	10	80	22	LD40303064 T8-40	T8
4N TE90-111-10-06-L80		1	11	10	80	11		
4N TE90-112-12-06-L100		1	12	12	100	26		
4N TE90-113-12-06-L100		1	13	12	100	13		
4N TE90-114-14-06-L120		1	14	14	120	30		
4N TE90-215-14-06-L120		2	15	14	120	15		
4N TE90-215.6-16-06-L150		2	15.6	16	150	34		
4N TE90-216-16-06-L120		2	16	16	120	35		
4N TE90-216-16-06-L160		2	16	16	160	35		
4N TE90-217-16-06-L160		2	17	16	160	17		
4N TE90-217-16-06-L200		2	17	16	200	22		
4N TE90-218-16-06-L160		2	18	16	160	18		
4N TE90-320-19-06-L120		3	20	19	120	20		
4N TE90-320-19-06-L160		3	20	19	160	20		
4N TE90-320-20-06-L120		3	20	20	120	44		
4N TE90-320-20-06-L160		3	20	20	160	44		
4N TE90-321-20-06-L160		3	21	20	160	21		
4N TE90-321-20-06-L200		3	21	20	200	22		
4N TE90-322-20-06-L160		3	22	20	160	22		
4N TE90-323-20-06-L160		3	23	20	160	23		
4N TE90-324-20-06-L160		3	24	20	160	24		
4N TE90-425-24-06-L120		4	25	24	160	25		
4N TE90-425-25-06-L120		4	25	25	120	55		
4N TE90-425-25-06-L160		4	25	25	160	55		
4N TE90-425-25-06-L200		4	25	25	200	55		
4N TE90-426-25-06-L160		4	26	25	160	26		
4N TE90-426-25-06-L200		4	26	25	200	26		
4N TE90-427-25-06-L160		4	27	25	160	27		
4N TE90-428-25-06-L160		4	28	25	160	28		
4N TE90-430-25-06-L160		4	30	25	160	30		
4N TE90-532-32-06-L160		5	32	32	160	70		
4N TE90-532-32-06-L200		5	32	32	200	70		
4N TE90-533-32-06-L160		5	33	32	160	33		
4N TE90-533-32-06-L200		5	33	32	200	33		

A

铣刀系列
Milling cutter series

A

铣刀系列
Milling cutter series

4N TF90刀盘系列
4N TF90 CUTTER HEAD SERIES

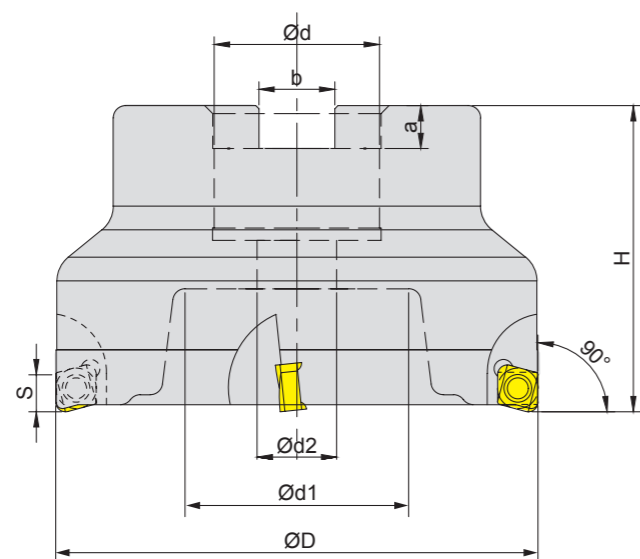

型号 Model		适用条件									螺丝 Screw	扳手 Wrench
		刃数	ϕD	ϕd	$\phi d1$	$\phi d2$	H	S	b	a		
4N TF90-535-16R-06	4NKT0603 特固克	5	35	16	14	9	40	5	8.4	7	LD40303064 T8-45	
4N TF90-640-16R-06		6	40	16	14	9	40	5	8.4	7		
4N TF90-650-22R-06		6	50	22	17	11	40	5	10.4	7		
4N TF90-863-22R-06		8	63	22	17	11	40	5	10.4	7		
4N TF90-1080-27R-06		10	80	27	34	13	50	5	12.4	7		
4N TF90-12100-32R-06		12	100	32	42	17	50	5	14.4	9		

MFSN 88°刀盘系列
MFSN 88° CUTTER HEAD SERIES

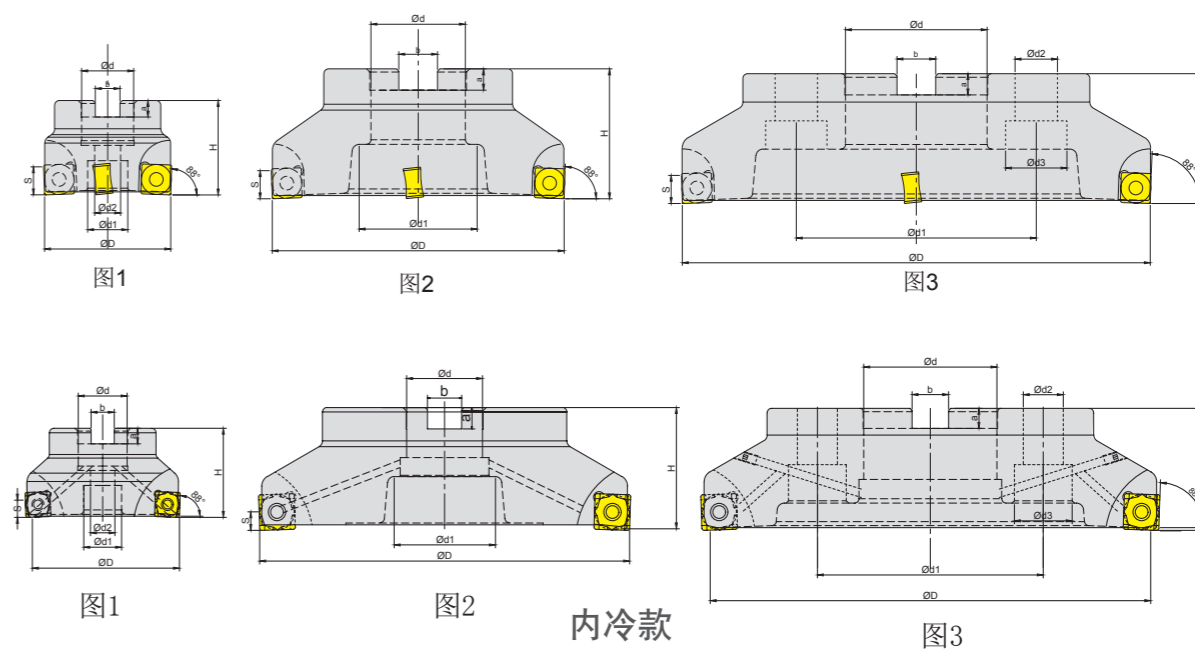
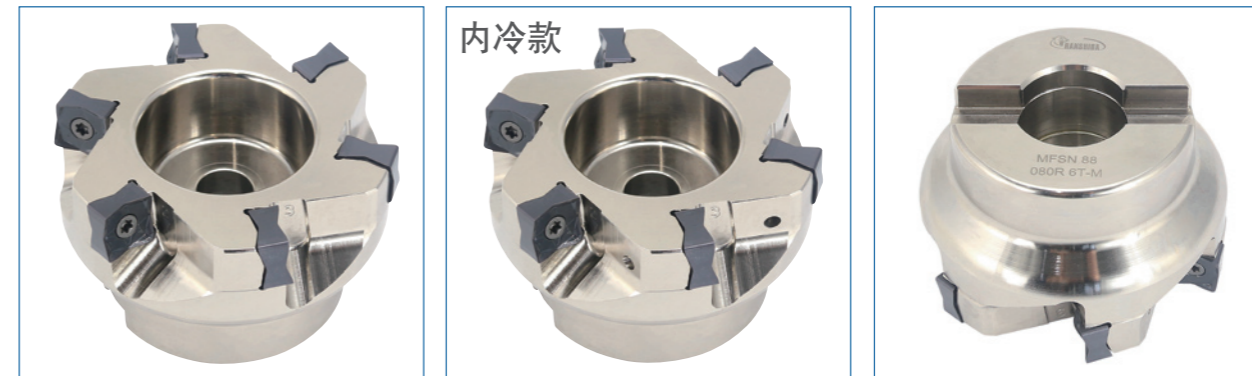

型号 Model		适用条件										螺丝 Screw	扳手 Wrench
		刃数	ϕD	ϕd	$\phi d1$	$\phi d2$	$\phi d3$	H	S	b	a		
MFSN 88 050R-4T-M	SNMU 130508 京瓷	4	50	22	17	11	-	40	5	10.4	7	图形1	LD55294010 T15-60
MFSN 88 063R-5T-M		5	63	22	17	11	-	40	5	10.4	7	图形1	
MFSN 88 080R-6T-M		6	80	27	34	13	-	50	5	12.4	7	图形1	
MFSN 88 100R-7T-M		7	100	32	42	17	-	50	5	14.4	9	图形1	
MFSN 88 125R-8T-M		8	125	40	50	-	-	55	5	16.4	9	图形2	
MFSN 88 160R-10T-M		10	160	40	80	-	-	55	5	16.4	9	图形2	
MFSN 88 200R-12T-M		12	200	60	101.6	18	26	55	5	25.4	14	图形3	
MFSN 88 250R-14T-M		14	250	60	101.6	18	26	55	5	25.4	14	图形3	

A

铣刀系列
Milling cutter series

A

铣刀系列
Milling cutter series

MFPN66°刀盘系列
MFPN66° CUTTER HEAD SERIES

新品

TEN09R 刀盘系列
TEN09R CUTTER HEAD SERIES

新品



图1

图2

图3

图1

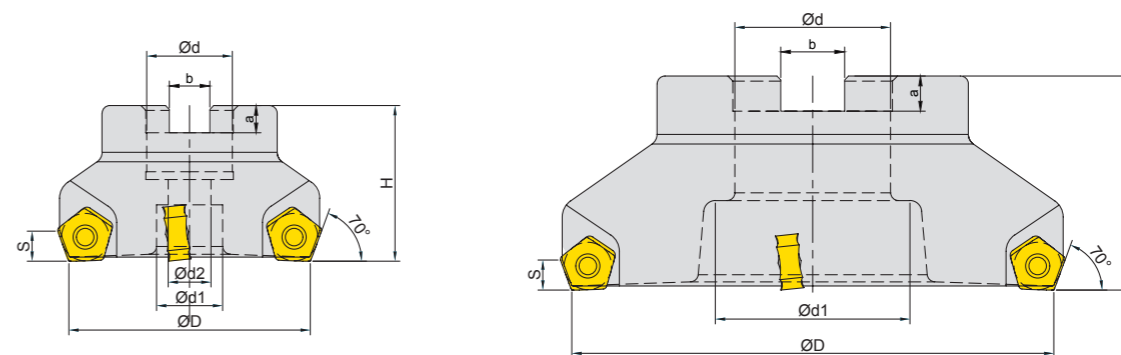
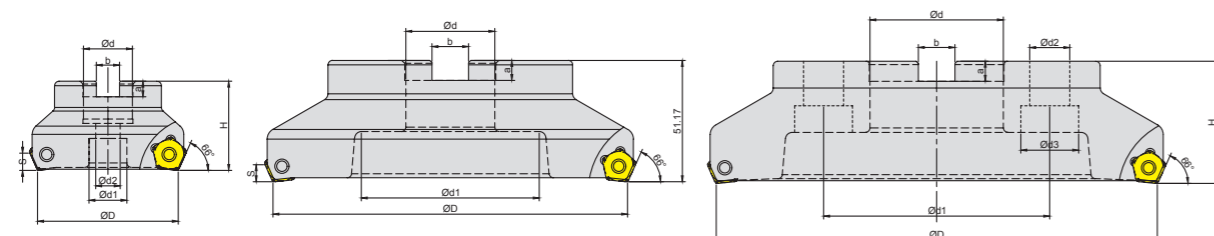
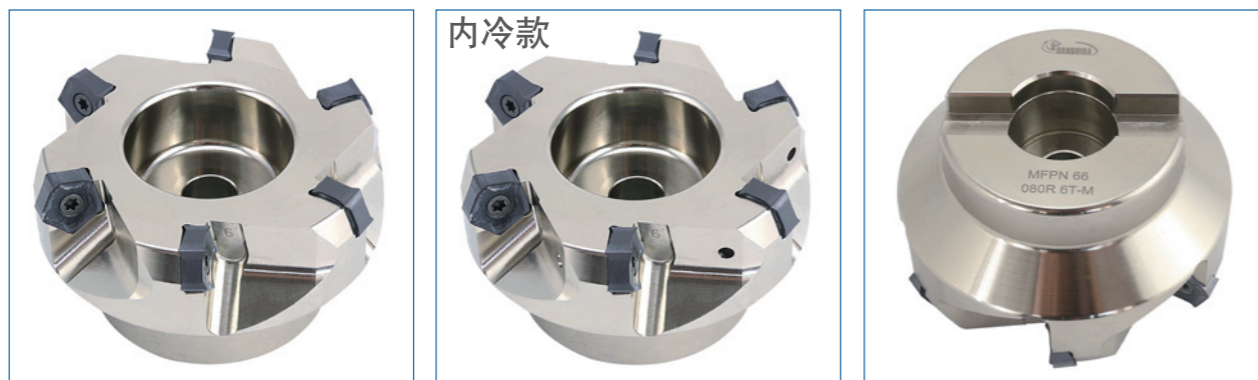
图2



图1

图2

图3

内冷款

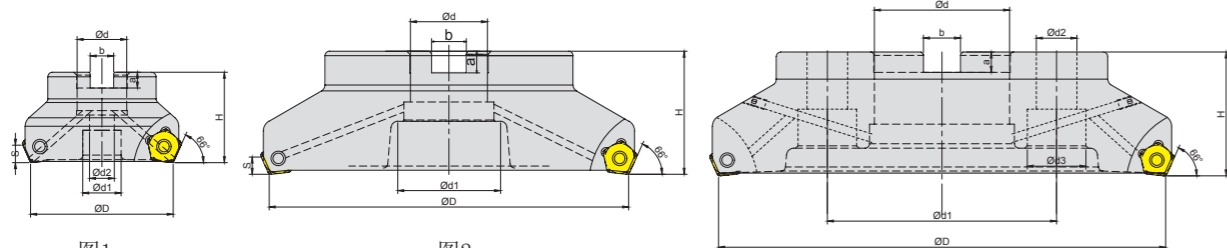
型号 Model		适用条件										螺丝 Screw	扳手 Wrench	
		刃数	ϕD	ϕd	ϕd_1	ϕd_2	ϕd_3	H	S	b	a			形状
MFPN 66 050R-4T-M	PNMU 0905 京瓷	4	50	22	17	11	-	40	7	10.4	7	图形1	LD55294010 T15-60	T-15
MFPN 66 063R-5T-M		5	63	22	17	11	-	40	7	10.4	7	图形1		
MFPN 66 080R-6T-M		6	80	27	34	13	-	50	7	12.4	7	图形1		
MFPN 66 100R-7T-M		7	100	32	42	17	-	50	7	14.4	9	图形1		
MFPN 66 125R-8T-M		8	125	40	50	-	-	55	7	16.4	9	图形2		
MFPN 66 160R-10T-M		10	160	40	80	-	-	55	7	16.4	9	图形2		
MFPN 66 200R-12T-M		12	200	60	101.6	18	26	55	7	25.4	9	图形3		
MFPN 66 250R-14T-M	14	250	60	101.6	18	26	55	7	25.4	9	图形3			

型号 Model		适用条件										螺丝 Screw	扳手 Wrench
		刃数	ϕD	ϕd	ϕd_1	ϕd_2	H	S	b	a	形状		
TEN09R 050M22.0-04	PNCU0905 东芝	4	50	22	17	11	40	6	10.4	7	图形1	LD55294010 T15-70	T-15
TEN09R 063M22.0-05		5	63	22	17	11	40	6	10.4	7	图形1		
TEN09R 080M27.0-06		6	80	27	34	13	50	6	12.4	7	图形1		
TEN09R 100M32.0-07		7	100	32	42	17	50	6	14.4	9	图形1		
TEN09R 125M40.0-08		8	125	40	50	-	55	6	16.4	9	图形2		
TEN09R 160M40.0-10		10	160	40	80	-	55	6	16.4	9	图形2		

A

铣刀系列
Milling cutter series

A

铣刀系列
Milling cutter series

FMZ88°刀盘系列
FMZ88° CUTTER HEAD SERIES

新品

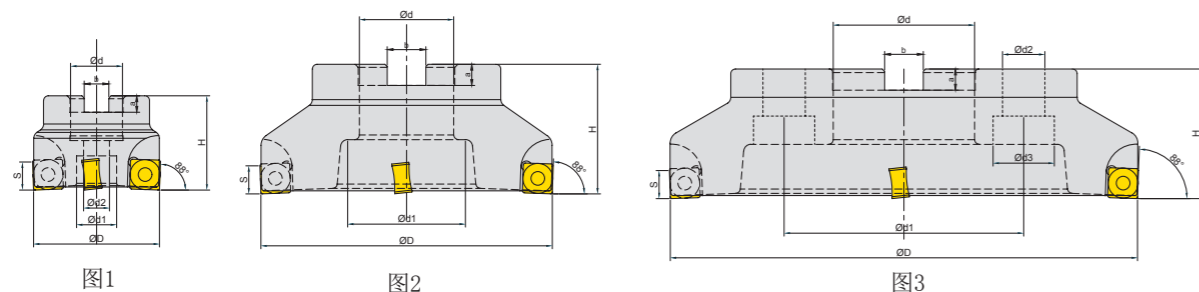
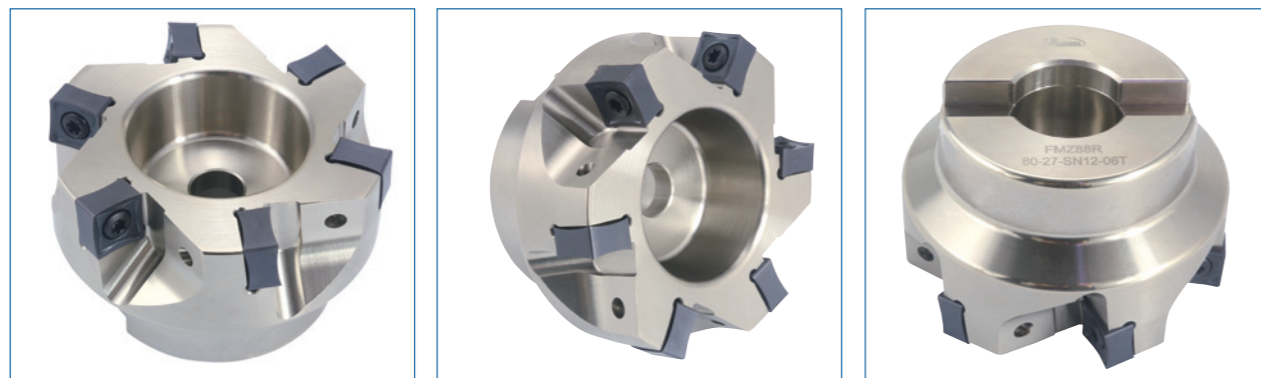

FME75°刀盘系列
FME75° CUTTER HEAD SERIES

新品

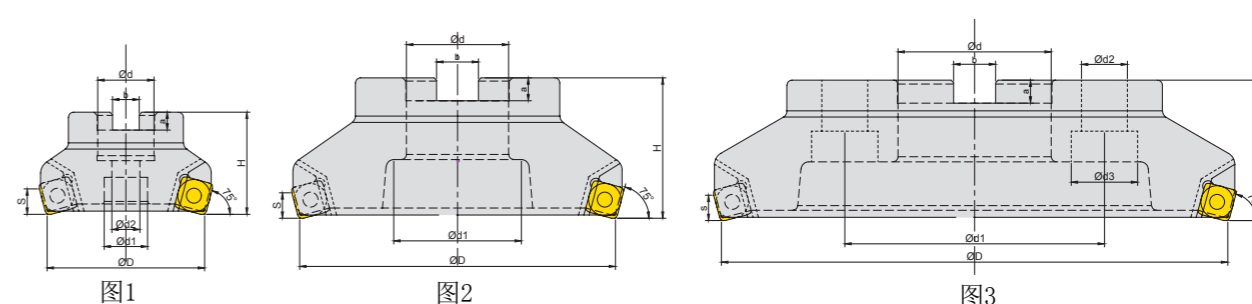
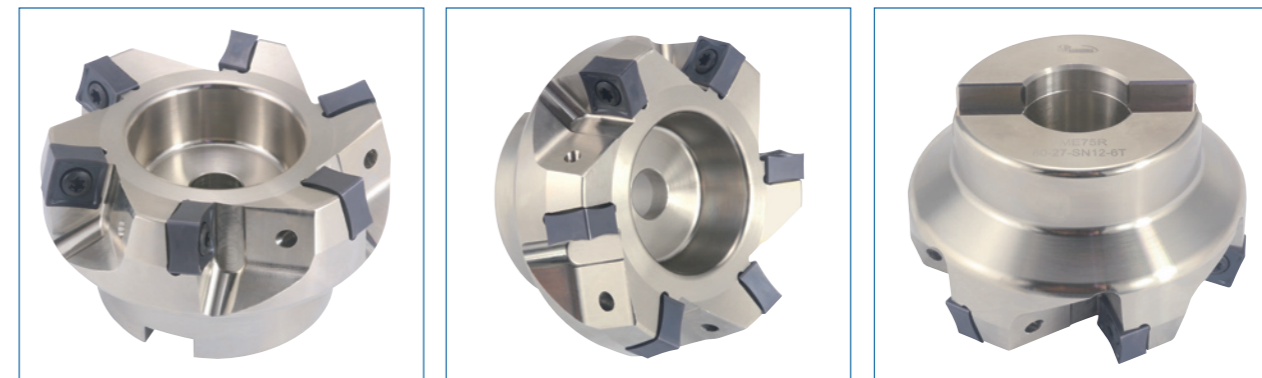

A

铣刀系列
Milling cutter series

A

铣刀系列
Milling cutter series

型号 Model		适用条件										形状	螺丝 Screw	扳手 Wrench	
		刃数	φD	φd	φd1	φd2	φd3	H	S	b	a				
FMZ88R-50-22-SN12-04T	SN1206 瓦尔特	4	50	22	17	11	-	40	10	10.4	7	图1	LD70R1255012 T20-60		
FMZ88R-55-22-SN12-04T		4	55	22	17	11	-	40	10	10.4	7	图1			
FMZ88R-63-22-SN12-05T		5	63	22	17	11	-	40	10	10.4	7	图1			
FMZ88R-70-22-SN12-05T		5	70	22	17	11	-	40	10	10.4	7	图1			
FMZ88R-80-27-SN12-06T		6	80	27	34	13	-	50	10	12.4	7	图1			
FMZ88R-100-32-SN12-07T		7	100	32	42	17	-	50	10	14.4	9	图1			
FMZ88R-125-40-SN12-08T		8	125	40	50	-	-	55	10	16.4	9	图2			
FMZ88R-160-40-SN12-10T		10	160	40	80	-	-	55	10	16.4	9	图2			
FMZ88R-200-60-SN12-12T		12	200	60	101.6	18	26	55	10	25.8	14	图3			
FMZ88R-250-60-SN12-14T		14	250	60	101.6	18	26	55	10	25.8	14	图3			

型号 Model		适用条件										形状	螺丝 Screw	扳手 Wrench	
		刃数	φD	φd	φd1	φd2	φd3	H	S	b	a				
FME75R-50-22-SN12-04T	SN1206 瓦尔特	4	50	22	17	11	-	40	8	10.4	7	图1	LD70R1255012 T20-60		
FME75R-55-22-SN12-04T		4	55	22	17	11	-	40	8	10.4	7	图1			
FME75R-63-22-SN12-05T		5	63	22	17	11	-	40	8	10.4	7	图1			
FME75R-70-22-SN12-05T		5	70	22	17	11	-	40	8	10.4	7	图1			
FME75R-80-27-SN12-06T		6	80	27	34	13	-	50	8	12.4	7	图1			
FME75R-100-32-SN12-07T		7	100	32	42	17	-	50	8	14.4	9	图1			
FME75R-125-40-SN12-08T		8	125	40	50	-	-	55	8	16.4	9	图2			
FME75R-160-40-SN12-10T		10	160	40	80	-	-	55	8	16.4	9	图2			
FME75R-200-60-SN12-12T		12	200	60	101.6	18	26	55	8	25.8	14	图3			
FME75R-250-60-SN12-14T		14	250	60	101.6	18	26	55	8	25.8	14	图3			

FMA45°刀盘系列
FMA45° CUTTER HEAD SERIES

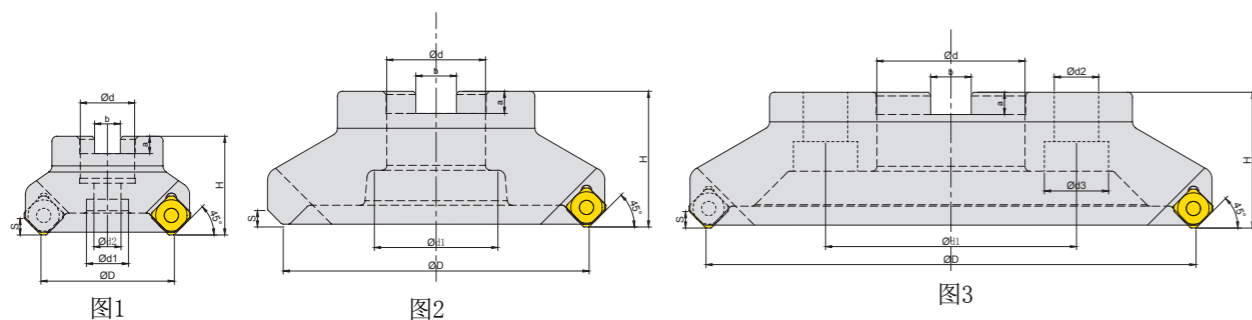

型号 Model		适用条件											形状	螺丝 Screw	扳手 Wrench
		刃数	φD	φd	φd1	φd2	φd3	H	S	b	a				
FMA45R-50-22-SN12-04T	SN1206 瓦尔特	4	50	22	17	11	-	40	5	10.4	7	图1	LD70R1255012 T20-60		
FMA45R-55-22-SN12-04T		4	55	22	17	11	-	40	5	10.4	7	图1			
FMA45R-63-22-SN12-05T		5	63	22	17	11	-	40	5	10.4	7	图1			
FMA45R-70-22-SN12-05T		5	70	22	17	11	-	40	5	10.4	7	图1			
FMA45R-80-27-SN12-06T		6	80	27	34	13	-	50	5	12.4	7	图1			
FMA45R-100-32-SN12-07T		7	100	32	42	17	-	50	5	14.4	9	图1			
FMA45R-125-40-SN12-08T		8	125	40	50	-	-	55	5	16.4	9	图2			
FMA45R-160-40-SN12-10T		10	160	40	80	-	-	55	5	16.4	9	图2			
FMA45R-200-60-SN12-12T		12	200	60	101.6	18	26	55	5	25.8	14	图3			
FMA45R-250-60-SN12-14T		14	250	60	101.6	18	26	55	5	25.8	14	图3			

SN 1206 45° 刀盘系列
SN 1206 45° CUTTER HEAD SERIES

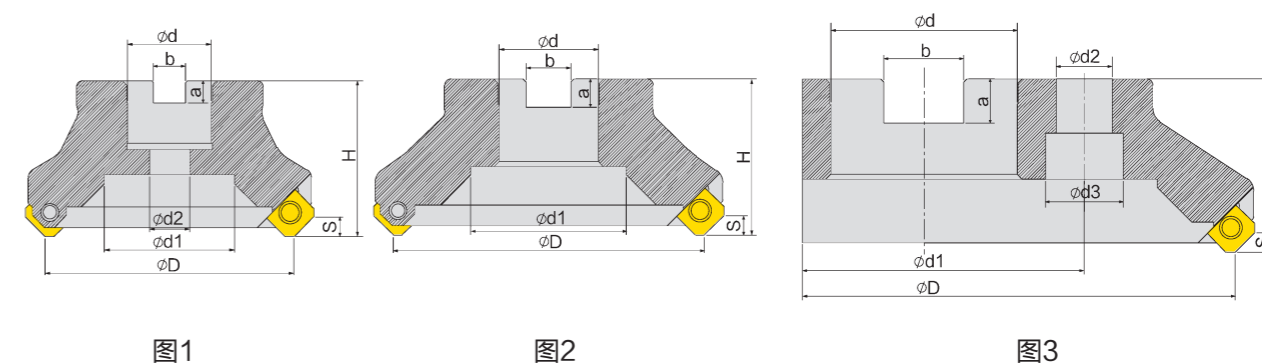
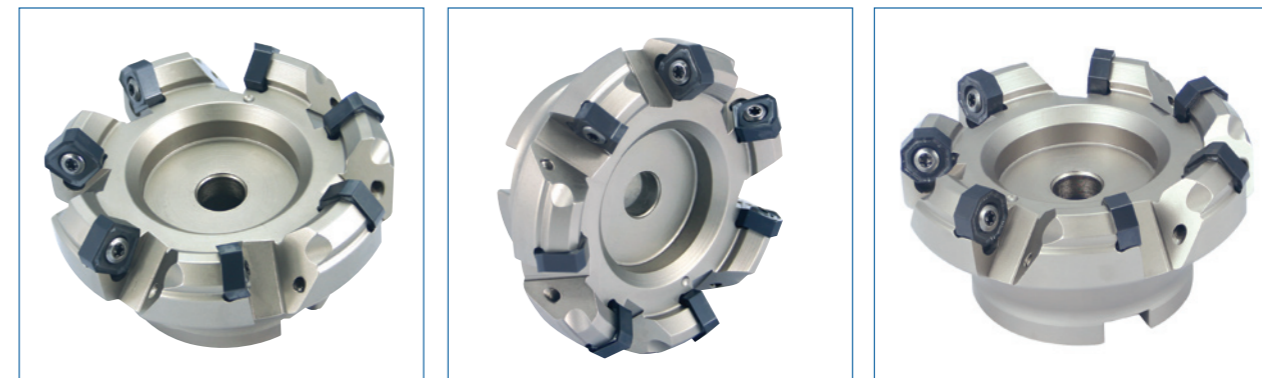

型号 Model		适用条件											形状	螺丝 Screw	扳手 Wrench
		刃数	φD	φd	φd1	φd2	φd3	H	S	b	a				
SOSF45-4/8-D050-04-22R	SNEU1206 依斯卡	4	50	22	17	11	-	40	5	10.4	7	图1	LD70344012 T15-70		
SOSF45-4/8-D055-04-22R		4	55	22	17	11	-	40	5	10.4	7	图1			
SOSF45-4/8-D063-04-22R		4	63	22	17	11	-	40	5	10.4	7	图1			
SOSF45-4/8-D063-05-22R		5	63	22	17	11	-	40	5	10.4	7	图1			
SOSF45-4/8-D070-05-22R		5	70	22	17	11	-	40	5	10.4	7	图1			
SOSF45-4/8-D080-05-27R		5	80	27	42	13	-	50	5	12.4	7	图1			
SOSF45-4/8-D080-06-27R		6	80	27	42	13	-	50	5	12.4	7	图1			
SOSF45-4/8-D100-06-32R		6	100	32	52	-	-	50	5	14.4	9	图2			
SOSF45-4/8-D100-08-32R		8	100	32	52	-	-	50	5	14.4	9	图2			
SOSF45-4/8-D125-08-40R		8	125	40	62	-	-	55	5	16.4	9	图2			
SOSF45-4/8-D160-08-40R		8	160	40	97	-	-	55	5	16.4	9	图2			
SOSF45-4/8-D160-10-40R		10	160	40	97	-	-	55	5	16.4	9	图2			
SOSF45-4/8-D200-12-60R		12	200	60	101.6	18	25	55	5	25.7	14	图3			
SOSF45-4/8-D250-14-60R		14	250	60	101.6	18	25	55	5	25.7	14	图3			

注：从315-400可以选用百变魔术刀盘

SN 1206 45° 刀盘系列
SN 1206 45° CUTTER HEAD SERIES



图1

图2

图3

型号 Model		适用条件										螺丝 Screw	扳手 Wrench		
		刃数	φD	φd	φd1	φd2	φd3	H	S	b	a			形状	
FMA45R(L)-050A22-SN12-04T	SNEU1206 金鹭	4	50	22	17	11	-	40	5	10.4	7	图1	LD70275012 T20-70		
FMA45R(L)-063A22-SN12-05T		5	63	22	17	11	-	40	5	10.4	7	图1			
FMA45R(L)-063A22-SN12-06T		6	63	22	17	11	-	40	5	10.4	7	图1			
FMA45R(L)-080B27-SN12-06T		6	80	27	42	13	-	50	5	12.4	7	图1			
FMA45R(L)-080B27-SN12-07T		7	80	27	42	13	-	50	5	12.4	7	图1			
FMA45R(L)-100B32-SN12-06T		6	100	32	52	-	-	50	5	14.4	9	图2			
FMA45R(L)-100B32-SN12-08T		8	100	32	52	-	-	50	5	14.4	9	图2			
FMA45R(L)-125C40-SN12-10T		10	125	40	62	-	-	55	5	16.4	9	图2			
FMA45R(L)-160C40-SN12-10T		10	160	40	97	-	-	55	5	16.4	9	图2			
FMA45R(L)-160C40-SN12-12T		12	160	40	97	-	-	55	5	16.4	9	图2			
FMA45R(L)-200C60-SN12-12T		12	200	60	101.6	18	25	55	5	25.7	14	图3			
FMA45R(L)-200C60-SN12-14T		14	200	60	101.6	18	25	55	5	25.7	14	图3			
FMA45R(L)-250C60-SN12-14T		14	250	60	101.6	18	25	55	5	25.7	14	图3			
FMA45R(L)-250C60-SN12-16T		16	250	60	101.6	18	25	55	5	25.7	14	图3			

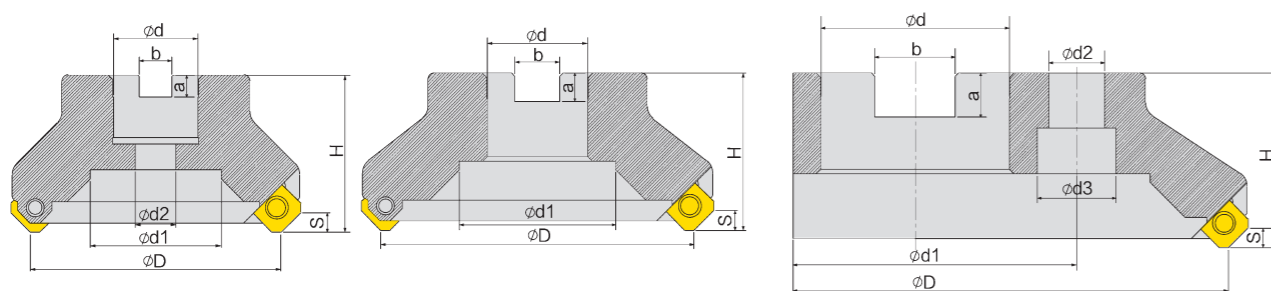
注：从250-400可以选用百变魔术刀盘

MFC45°-07刀盘系列
MFC45°-07 CUTTER HEAD SERIES



图1

图2

型号 Model		适用条件										螺丝 Screw	扳手 Wrench	
		刃数	φD	φd	φd1	φd2	H	S	b	a	形状			
MFC145050R04A22HN07	HNPJ0704 威迪亚	4	50	22	17	11	40	3.5	10.4	7	图1	LD55294010 T15-60		
MFC145063R05A22HN07		5	63	22	17	11	40	3.5	10.4	7	图1			
MFC145080R06A27HN07		6	80	27	34	13	50	3.5	12.4	7	图1			
MFC1450100R07A32HN07		7	100	32	42	17	50	3.5	14.4	9	图1			
MFC1450125R08A40HN07		8	125	40	50	-	55	3.5	16.4	9	图2			
MFC1450160R10A40HN07		10	160	40	80	-	55	3.5	16.4	9	图2			

MFC45°-09刀盘系列
MFC45°-09 CUTTER HEAD SERIES

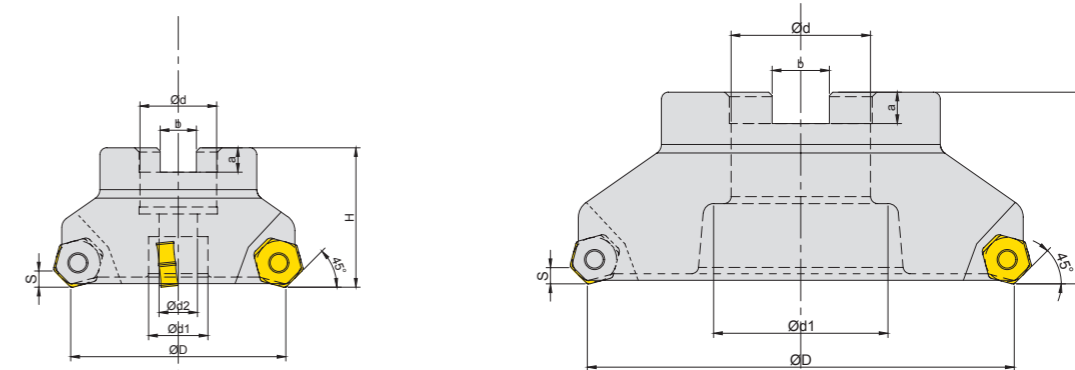
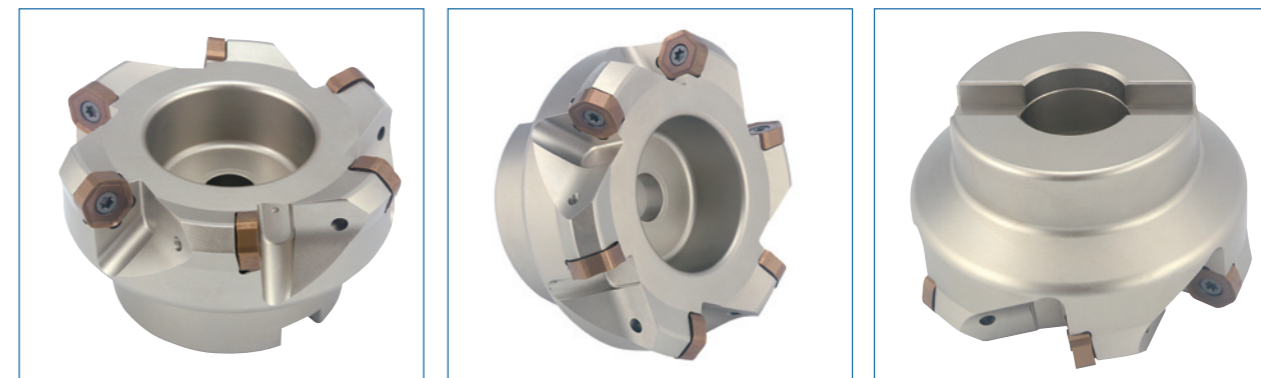
新品

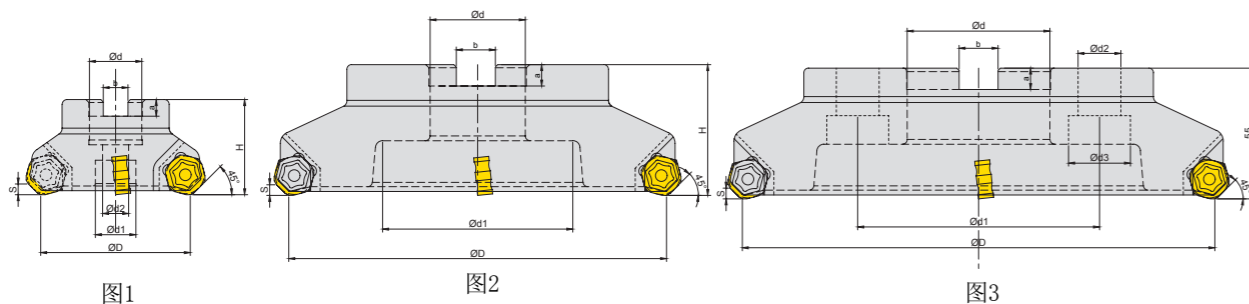

型号 Model		适用条件										形状	螺丝 Screw	扳手 Wrench	
		刃数	ϕD	ϕd	$\phi d1$	$\phi d2$	$\phi d3$	H	S	b	a				
MFC145050R04A22HN09	HNGU0905 威迪亚	4	50	22	17	11	-	40	3.5	10.4	7	图1	LD60294011 T15-60		
MFC145063R05A22HN09		5	63	22	17	11	-	40	3.5	10.4	7	图1			
MFC145080R06A27HN09		6	80	27	34	13	-	50	3.5	12.4	7	图1			
MFC1450100R07A32HN09		7	100	32	42	17	-	50	3.5	14.4	9	图1			
MFC1450125R08A40HN09		8	125	40	50	-	-	55	3.5	16.4	9	图2			
MFC1450160R10A40HN09		10	160	40	80	-	-	55	3.5	16.4	9	图2			
MFC1450200R12A60HN09		12	200	60	101.6	18	26	55	3.5	25.8	14	图3			
MFC1450250R14A60HN09		14	250	60	101.6	18	26	55	3.5	25.8	14	图3			

TFM45°刀盘系列
TFM45° CUTTER HEAD SERIES

新品

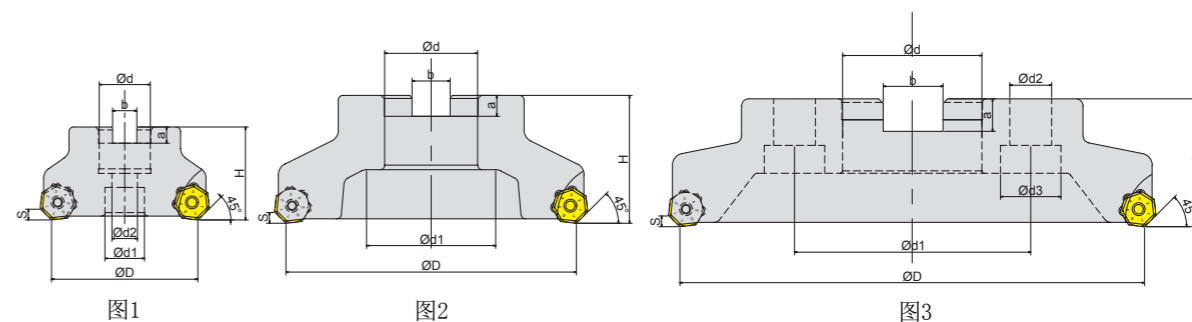

型号 Model		适用条件										形状	螺丝 Screw	扳手 Wrench	
		刃数	ϕD	ϕd	$\phi d1$	$\phi d2$	$\phi d3$	H	S	b	a				
TFM45-AN0705-D50-22-4T	XN0705 瓦尔特	4	50	22	17	11	-	40	3.5	10.4	7	图1	LD60294011 T15-60		
TFM45-AN0705-D63-22-5T		5	63	22	17	11	-	40	3.5	10.4	7	图1			
TFM45-AN0705-D80-27-6T		6	80	27	34	13	-	50	3.5	12.4	7	图1			
TFM45-AN0705-D100-32-7T		7	100	32	42	17	-	50	3.5	14.4	9	图1			
TFM45-AN0705-D125-40-8T		8	125	40	50	-	-	55	3.5	16.4	9	图2			
TFM45-AN0705-D160-40-10T		10	160	40	80	-	-	55	3.5	16.4	9	图2			
TFM45-AN0705-D200-60-12T		12	200	60	101.6	18	26	55	3.5	25.8	14	图3			

A

铣刀系列
Milling cutter series

A

铣刀系列
Milling cutter series

TFM55° 铣刀盘系列
TFM55° FACING CUTTER SERIES

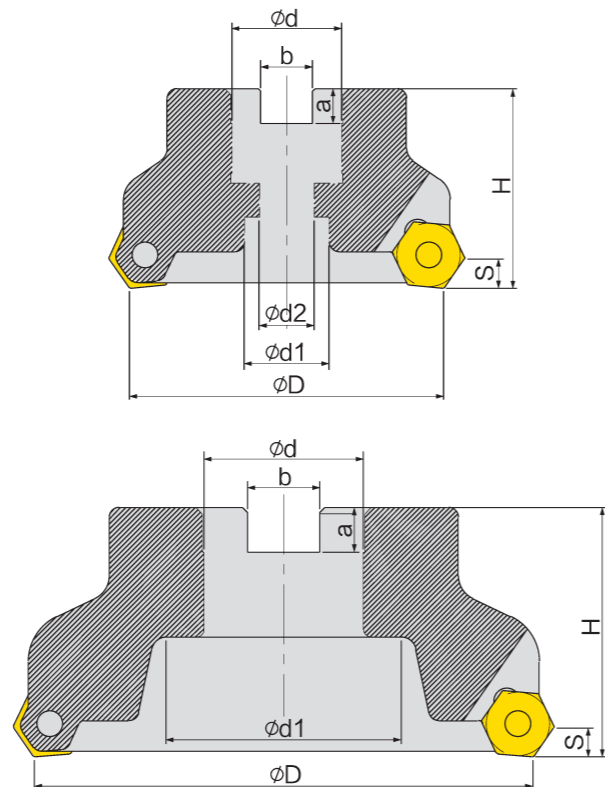
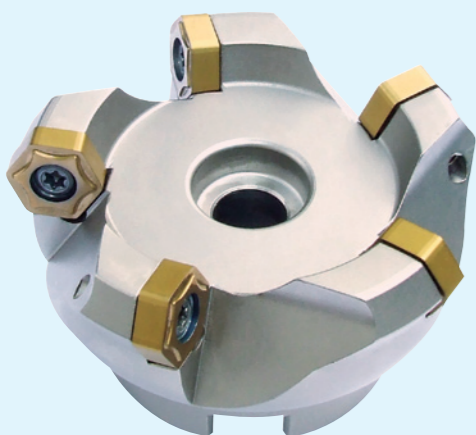

型号 Model	刃数 Blade number		D	D1	L1	ap	螺丝 Screw	扳手 Wrench
TFM55AHNS 050 4T 22	4		50	22	40	4	LD72255012 T15-80	T-15
TFM55AHNS 063 5T 22	5	HNMX050410-MM	63	22	40	4		
TFM55AHNS 080 6T 27	6		80	27	50	4		
TFM55AHNS 100 7T 32	7	HNCX050410-MM	100	32	50	4		
TFM55AHNS 125 8T 40	8	HNCX05R-W	125	40	63	4		
TFM55AHNS 160 9T 40	9		160	40	63	4		

注：从200-400可以选用百变魔术刀盘

- 以上型号均配特固克刀片
亦可根据要求来函定做各种非标



此款 HNMX050410匹配的是特固克的刀片槽



此款 HNMX050410匹配的是悍狮霸的刀片槽

SE13T3 45° 刀盘系列
SE13T3 45° CUTTER HEAD SERIES



图1

图2

图3

型号 Model		适用条件										螺丝 Screw	扳手 Wrench
		齿数	ϕD	ϕd	$\phi d1$	$\phi d2$	$\phi d3$	H	S	b	a		
MFPN SE13 050 4T 22-R/L	SEMT13T3	4	50	22	17	11	-	40	6.5	8.4	6	图1	LD53273580 T15-45
MFPN SE13 055 4T 22-R/L		4	55	22	17	11	-	40	6.5	10.4	7	图1	
MFPN SE13 063 4T 22-R/L		4	63	22	17	11	-	40	6.5	10.4	7	图1	
MFPN SE13 063 5T 22-R/L		5	63	22	17	11	-	40	6.5	12.4	7	图1	
MFPN SE13 070 5T 22-R/L		5	70	22	17	11	-	40	6.5	10.4	7	图1	
MFPN SE13 080 5T 27-R/L		5	80	27	19	13	-	50	6.5	10.4	7	图2	
MFPN SE13 080 6T 27-R/L		6	80	27	19	13	-	50	6.5	10.4	7	图2	
MFPN SE13 100 6T 32-R/L		6	100	32	48	-	-	50	6.5	10.4	7	图2	
MFPN SE13 100 8T 32-R/L		8	100	32	48	-	-	50	6.5	12.4	7	图2	
MFPN SE13 125 8T 40-R/L		8	125	40	62	-	-	55	6.5	12.4	7	图2	
MFPN SE13 160 8T 40-R/L		8	160	40	82	-	-	55	6.5	14.4	9	图2	
MFPN SE13 160 10T 40-R/L		10	160	40	82	-	-	55	6.5	14.4	9	图2	
MFPN SE13 200 12T 60-R/L		12	200	60	101.6	18	25	55	6.5	25.7	14	图3	
MFPN SE13 250 14T 60-R/L		14	250	60	101.6	18	25	55	6.5	25.7	14	图3	

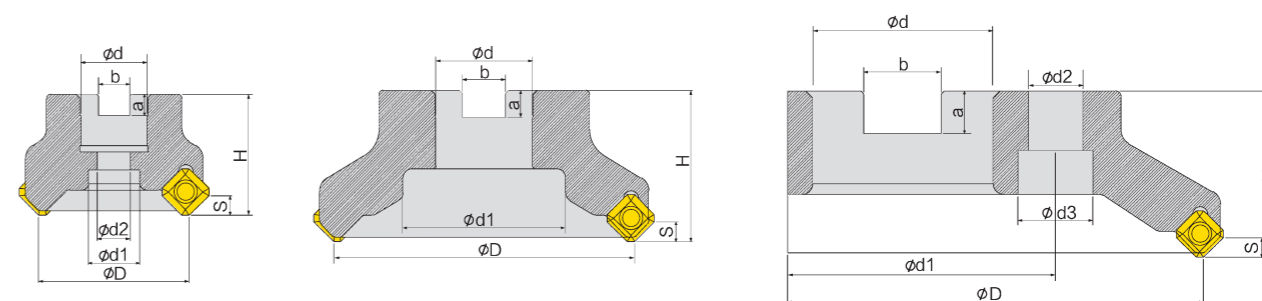
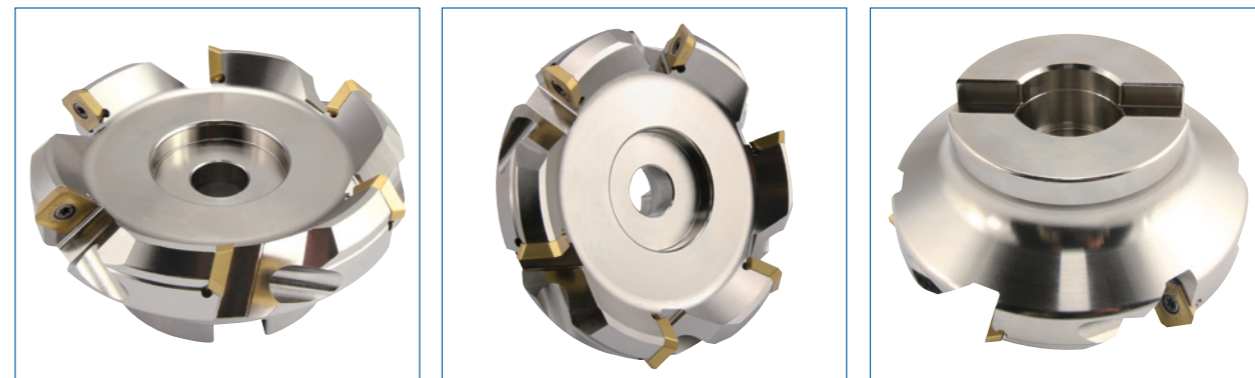
注：从315-400可以选用百变魔术刀盘

OD 45° 刀盘系列
OD 45° CUTTER HEAD SERIES



图1

图2

型号 Model		适用条件										螺丝 Screw	扳手 Wrench
		齿数	φD	φd	φd1	φd2	H	S	b	a	形状		
F4080 B22 050 Z04 04	ODHT 0504ZZN	4	50	22	17	11	40	3.5	10.4	7	图1	LD57294010	T-15
F4080 B22 063 Z05 04		5	63	22	17	11	40	3.5	10.4	7	图1		
F4080 B27 080 Z06 04		6	80	27	19	13	50	3.5	12.4	7	图1		
F4080 B32 100 Z08 04		8	100	32	40.5	-	50	3.5	14.4	9	图2		
F4080 B40 125 Z10 04		10	125	40	62	-	55	3.5	16.4	9	图2		

注：从160-400可以选用百变魔术刀盘

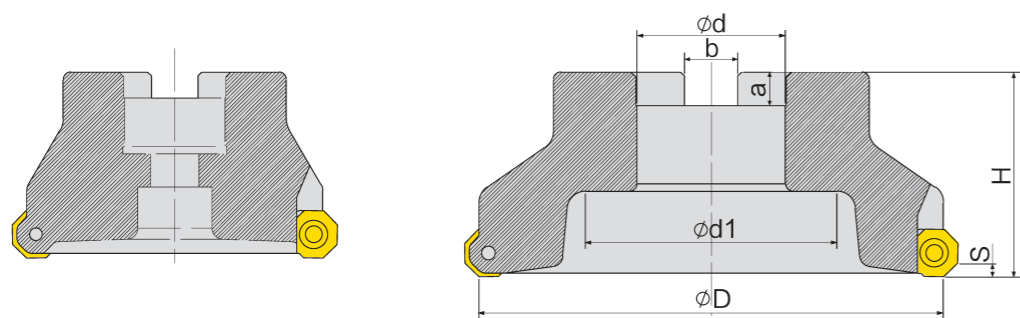
SE1204 45° 刀盘系列
SE1204 45° CUTTER HEAD SERIES



图1

图2

图3

型号 Model		适用条件										螺丝 Screw	扳手 Wrench	
		齿数	φD	φd	φd1	φd2	φd3	H	S	b	a			形状
MFPN SE12 050 4T 22-R/L	SEMT1204	4	50	22	17	11	-	40	6.5	8.4	6	图1	LD70275012	T-20
MFPN SE12 055 4T 22-R/L		4	55	22	17	11	-	40	6.5	10.4	7	图1		
MFPN SE12 063 4T 22-R/L		4	63	22	17	11	-	40	6.5	10.4	7	图1		
MFPN SE12 063 5T 22-R/L		5	63	22	17	11	-	40	6.5	12.4	7	图1		
MFPN SE12 070 5T 22-R/L		5	70	22	17	11	-	40	6.5	10.4	7	图1		
MFPN SE12 080 5T 27-R/L		5	80	27	19	13	-	50	6.5	10.4	7	图2		
MFPN SE12 080 6T 27-R/L		6	80	27	19	13	-	50	6.5	10.4	7	图2		
MFPN SE12 100 6T 32-R/L		6	100	32	48	-	-	50	6.5	10.4	7	图2		
MFPN SE12 100 8T 32-R/L		8	100	32	48	-	-	50	6.5	12.4	7	图2		
MFPN SE12 125 8T 40-R/L		8	125	40	62	-	-	55	6.5	12.4	7	图2		
MFPN SE12 160 8T 40-R/L		8	160	40	82	-	-	55	6.5	14.4	9	图2		
MFPN SE12 160 10T 40-R/L		10	160	40	82	-	-	55	6.5	14.4	9	图2		
MFPN SE12 200 12T 60-R/L		12	200	60	101.6	18	25	55	6.5	25.7	14	图3		
MFPN SE12 250 14T 60-R/L		14	250	60	101.6	18	25	55	6.5	25.7	14	图3		

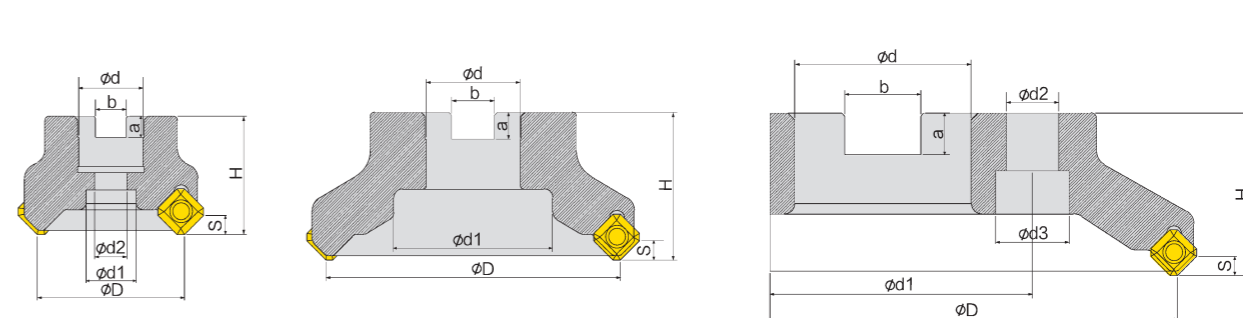
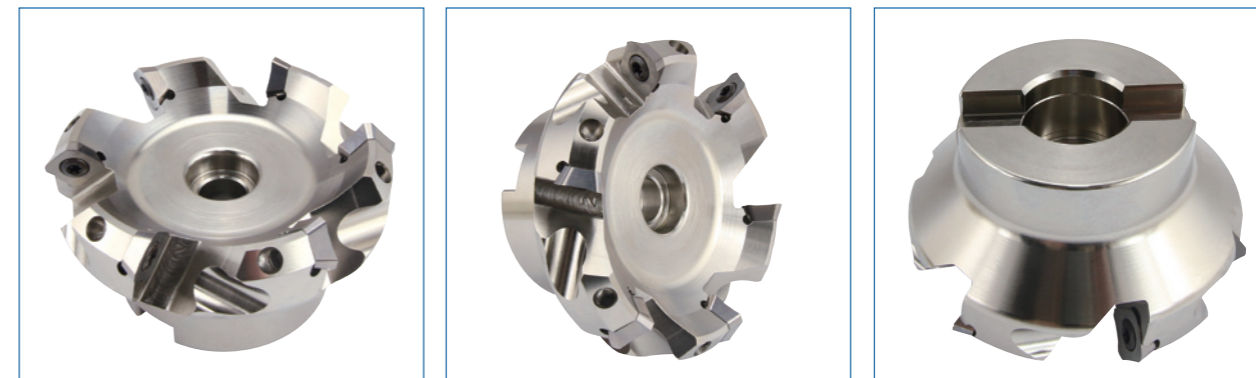
注：从315-400可以选用百变魔术刀盘

SN 75° 开粗刀盘系列
SN 75° CUTTER HEAD SERIES



图1

图2

图3

型号 Model	适用条件	双头螺丝 Double Screw	挤块 Clamp	扳手 Wrench										
					刃数	φD	φd	φd1	φd2	H	S	b	a	形状
FME01(L)063-SN09-22-07	SNEN 0904ENS SNMT 0904	ST0620	FME01 JK1011-09	L3.0	7	63	22	17	11	40	14	10.4	7	图1
FME01(L)080-SN09-22-08					8	80	27	36.5	13	50	14	12.4	7	图1
FME01(L)100-SN09-32-12					12	100	32	45.5	-	50	14	14.4	9	图2
FME01(L)125-SN09-40-14					14	125	40	55.5	-	55	14	16.4	9	图2
FME01(L)063-SN12-22-04	SNMT 1204 SNEN 1204ZZ	ST0620	FME01 JK1012-12	L3.0	4	63	22	17	11	40	14	10.4	7	图1
FME01(L)063-SN12-22-06					6	63	22	17	11	40	14	10.4	7	图1
FME01(L)080-SN12-27-06					6	80	27	35	13	50	14	12.4	7	图1
FME01(L)080-SN12-27-08					8	80	27	35	13	50	14	12.4	7	图1
FME01(L)100-SN12-32-08					8	100	32	45	-	50	14	14.4	9	图2
FME01(L)100-SN12-32-10					10	100	32	45	-	50	14	14.4	9	图2
FME01(L)100-SN12-32-12					12	100	32	45	-	50	14	14.4	9	图2
FME01(L)125-SN12-40-08					8	125	40	55	-	55	14	16.4	9	图2
FME01(L)125-SN12-40-12					12	125	40	55	-	55	14	16.4	9	图2
FME01(L)160-SN12-40-10					10	160	40	90	-	55	14	16.4	9	图2
FME01(L)160-SN12-40-14					14	160	40	90	-	55	14	16.4	9	图2
FME01(L)200-SN12-60-12					12	200	60	101.6	18	55	14	25.7	14	图3
FME01(L)200-SN12-60-16					16	200	60	101.6	18	55	14	25.7	14	图3
FME01(L)250-SN12-60-15					15	250	60	101.6	18	55	14	25.7	14	图3
FME01(L)250-SN12-60-20					20	250	60	101.6	18	55	14	25.7	14	图3

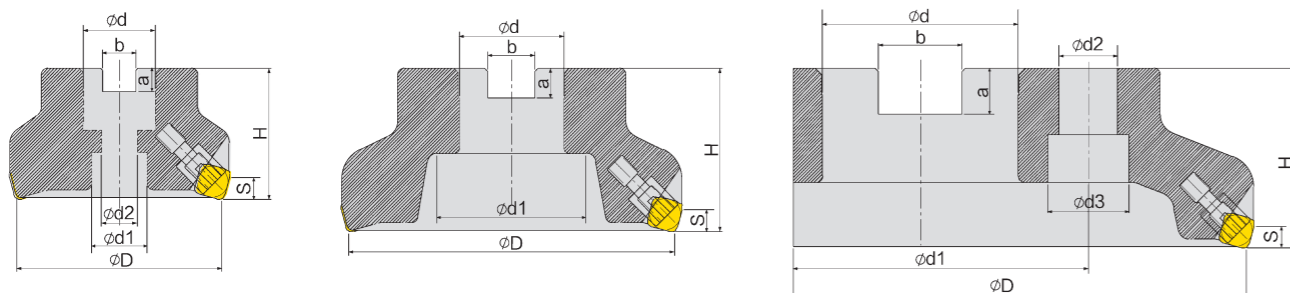
CBN和车刀片通用

CBN 75° 精加工带修光刃刀盘系列
CBN75° SERIES OF CUTTING EDGE KNIVES AND DISCS IN FINE PROCESSING BELT



图1

图2

图3

型号 Model	适用条件	挤块 Clamp	修光调 节块	修光刀 夹调节 螺丝	修光刀 夹固定 螺丝	双头 螺丝	修光 刀夹	扳手 Wrench												
									修光 刃数	刃数	φD	φd	φd1	φd2	φd3	H	S	b	a	形状
FME02(L)-063-SN09-22-07	修光刀夹 固定螺丝	FME02 JK1012-11	FME TJ1010 -09	ST0617	NLJ0415	ST0620 NLJ0420	FME02 XGDJ -1624	L3.0	1	6	63	22	17	11	-	50	5	10.4	7	图1
FME02(L)-080-SN09-27-09									2	7	80	27	32	13	-	50	5	12.4	7	图1
FME02(L)-100-SN09-32-12									2	10	100	32	40	-	-	50	5	14.4	9	图2
FME02(L)-125-SN09-40-14									2	12	125	40	50	-	-	55	5	16.4	9	图2
FME02(L)-160-SN09-32-18									3	15	160	40	86	-	-	55	5	16.4	9	图2
FME02(L)-200-SN09-60-20									4	16	200	60	101.6	18	25	55	5	25.7	14	图3
FME02(L)-250-SN09-60-25	5	20	250	60	101.6	18	25	55	5	25.7	14	图3								

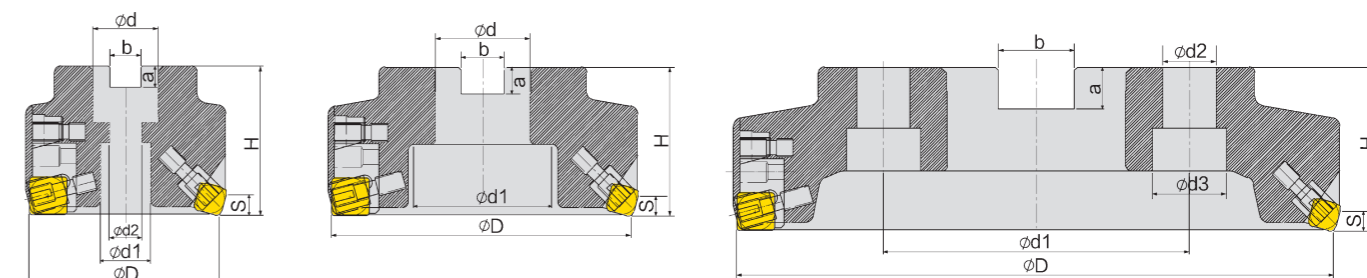
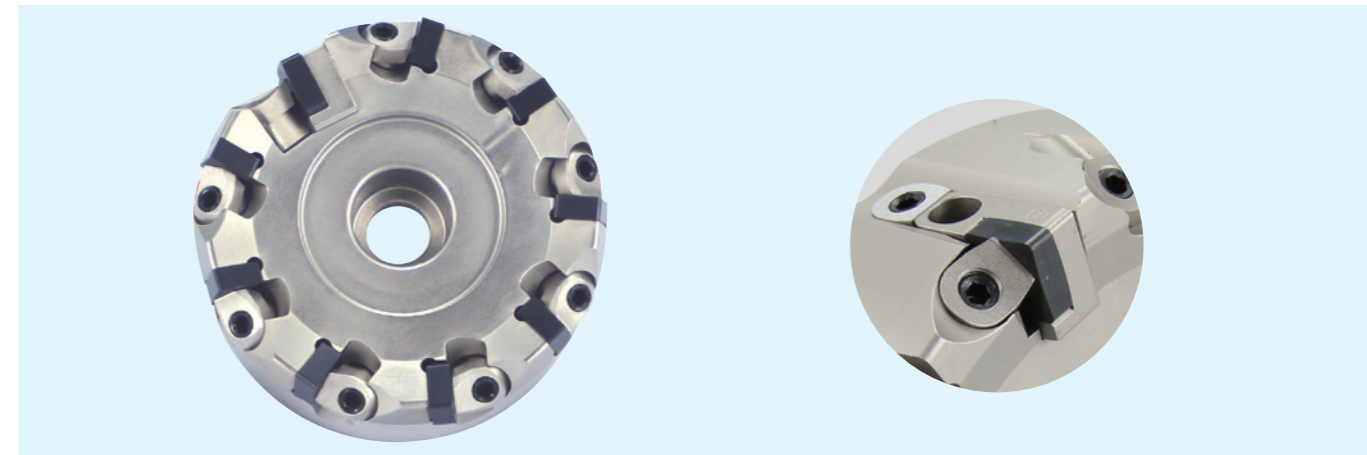
TP 90° 刀盘系列
TP 90° CUTTER HEAD SERIES



图1



图2

型号 Model		适用条件										螺丝 Screw	扳手 Wrench
		刃数	ϕD	ϕd	ϕd_1	ϕd_2	H	S	b	a	形状		
TP9013-063-22-3T	TP...2204...	3	63	22	17	11	50	19	10.4	7	图1	MGT190821	L5.0
TP9013-080-27-4T		4	80	27	34.5	13	50	19	12.4	7	图1		
TP9013-100-32-5T		5	100	32	45	-	50	19	14.4	9	图2		
TP9013-125-40-6T		6	125	40	65	-	55	19	16.4	9	图2		
TP9013-160-40-7T		7	160	40	86	-	55	19	16.4	9	图2		

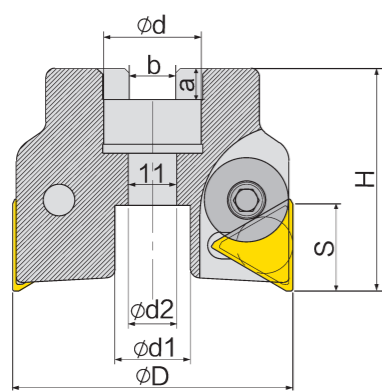
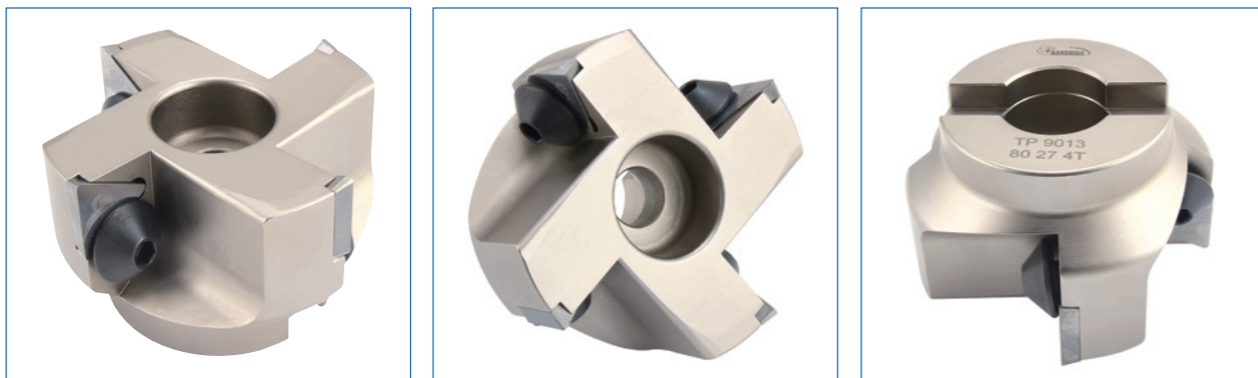
SP 75° 刀盘系列
SP 75° CUTTER HEAD SERIES

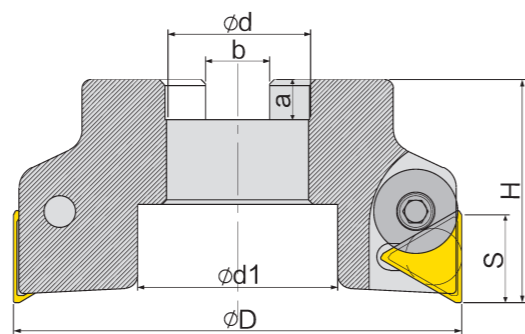

图4



图1

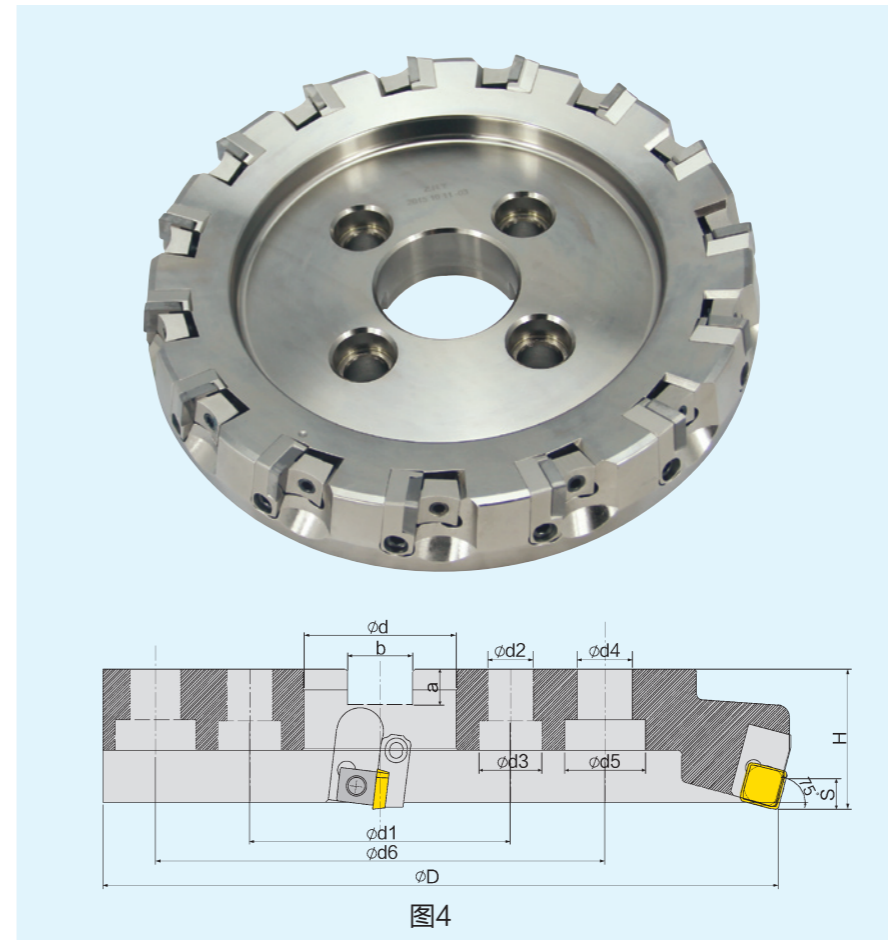

图2

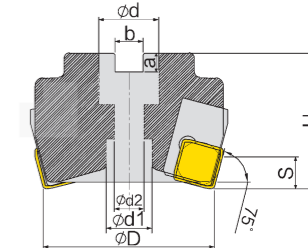

图3

型号 Model		适用条件														固定螺丝 Clamp Screw	双头螺丝 Double Screw	刀夹 The knife clip	挤块 Squeeze block	扳手 Wrench
		刃数	ϕD	ϕd	ϕd_1	ϕd_2	ϕd_3	ϕd_4	ϕd_5	ϕd_6	H	S	b	a	形状					
FP75-063-22-3T	SPMT1504	3	63	22	17	11	-	-	-	-	50	12	10.4	7	图1	NLJ0525	ST0818	FP-DJ2012	FP75	L4.0
FP75-080-27-5T		5	80	27	19	13	-	-	-	-	50	12	12.4	7	图1					
FP75-100-32-6T		6	100	32	43	-	-	-	-	-	50	12	14.4	9	图2					
FP75-125-40-8T		8	125	40	61	-	-	-	-	-	55	12	16.4	9	图2					
FP75-160-40-10T		10	160	40	96	-	-	-	-	-	55	12	16.4	9	图2					
FP75-200-60-12T		12	200	60	101.6	18	25	-	-	-	55	12	25.7	14	图3					
FP75-250-60-15T		15	250	60	101.6	18	25	-	-	-	55	12	25.7	14	图3					
FP75-315-60-18T		18	315	60	101.6	18	25	-	-	-	55	12	25.7	14	图4					
FP75-350-60-20T		20	350	60	101.6	18	25	22	32	177.8	55	12	25.7	14	图4					
FP75-400-60-24T		24	400	60	101.6	18	25	22	32	177.8	55	12	25.7	14	图4					
FP75-500-60-30T	30	500	60	101.6	18	25	22	32	177.8	55	12	25.7	14	图4						

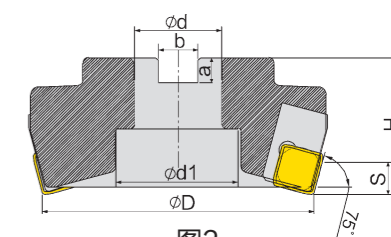
BRP系列锁牙刀头
BRP SERIES OF LOCK TOOL HEAD

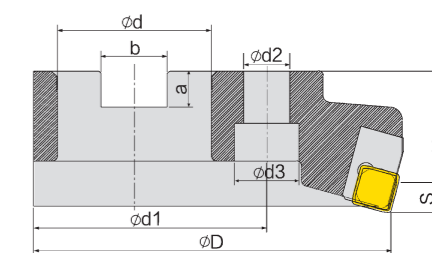
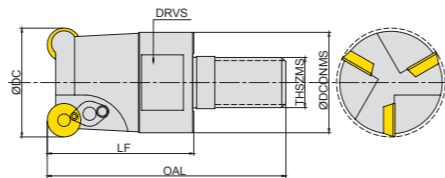
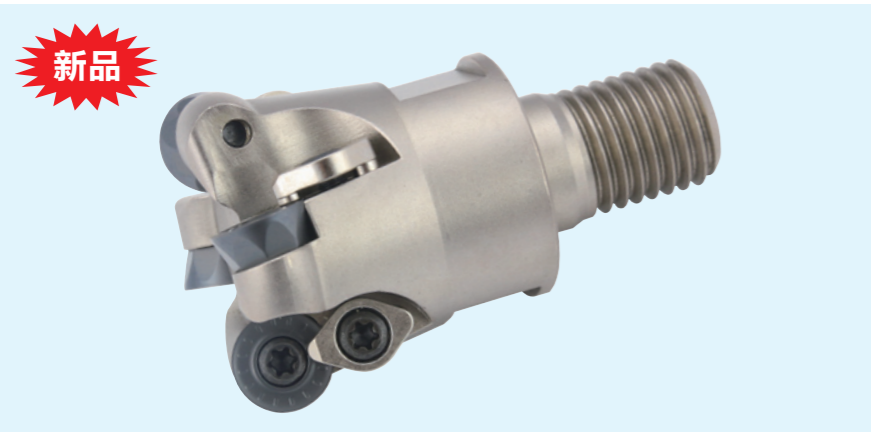

型号 Model	适用条件	压板 Pressing plate	螺丝 Screw	板手 Wrench											
					刃数	φDc	φDCNMS	LF	OAL	THSZMS	DRVS				
BRP 4R 16 1T M8	RP08T2	R4YD	LD40303064	T-8	1	16	15	25	43	M08	13				
BRP 4R 17 2T M8					2	17	15	25	43	M08	13				
BRP 4R 20 2T M10					2	20	19	29	49	M10	15				
BRP 4R 25 3T M12					3	25	24	35	57	M12	19				
BRP 4R 26 3T M12	RP10T3	R5YD	LD53273580	T-15	3	26	24	35	57	M12	19				
BRP 5R 21 2T M10					2	21	19	29	49	M10	15				
BRP 5R 25 2T M12					2	25	24	35	57	M12	19				
BRP 5R 26 2T M12					2	26	24	35	57	M12	19				
BRP 5R 32 3T M16					3	32	31	38	63	M16	24				
BRP 5R 33 3T M16					3	33	31	38	63	M16	24				
BRP 5R 35 3T M16					3	35	31	38	63	M16	24				
BRP 6R 25 2T M12					RP1204	R6YD	LD57274010	T-15	2	25	24	35	57	M12	19
BRP 6R 26 2T M12									2	26	24	35	57	M12	19
BRP 6R 32 2T M16									2	32	31	38	63	M16	24
BRP 6R 33 2T M16	2	33	31	38					63	M16	24				
BRP 6R 35 3T M16	RP1204	R6YD	LD57274010	T-15	3	35	31	38	63	M16	24				
BRP 6R 40 4T M16					4	40	31	38	63	M16	24				

EMR系列铣刀杆
EMR SERIES MILLING CUTTER BAR

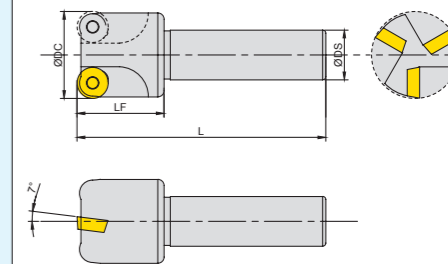

型号 Model	适用条件	螺丝 Screw	板手 Wrench					
				刃数	φDC	φDS	L	LF
EMR-21-S16-80 R5 2T	RP10T3	LD53273580	T-15	2	21	16	80	30
EMR-25-S16-80 R5 2T				2	25	16	80	30
EMR-28-S16-80 R5 3T				3	28	16	80	30
EMR-30-S16-80 R5 3T				3	30	16	80	30
EMR-32-S16-80 R5 3T				3	32	16	80	30
EMR-35-S16-80 R5 3T				3	35	16	80	30
EMR-40-S16-80 R5 3T				3	40	16	80	30

A

铣刀系列
Milling cutter series

A

铣刀系列
Milling cutter series

直杆铣刀SBRP系列
STRAIGHT BAR MILLER CUTTER SBRP SERIES

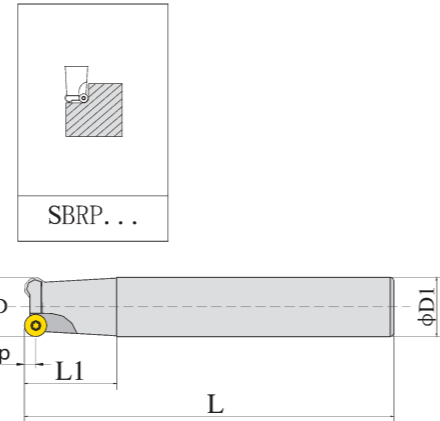
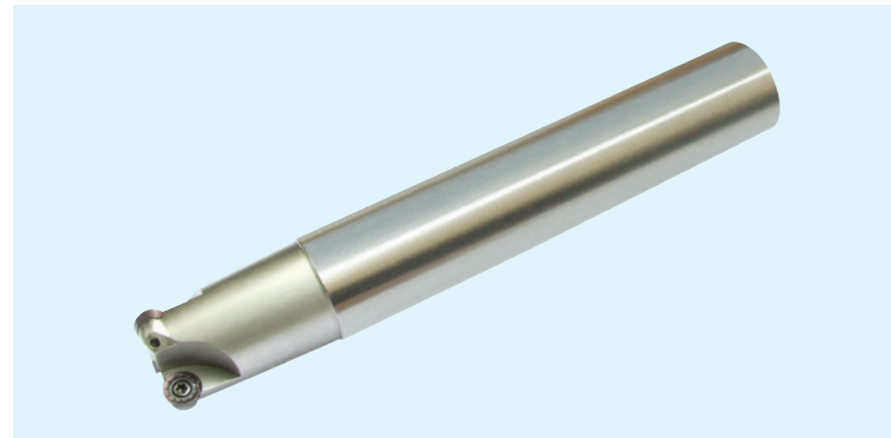

型号 Model	刃数 Blade number		D	D1	L	ap	螺丝 Screw	扳手 Wrench
SBRP4R 14 1T 14-120	1	RP08T2	14	14	120	4	LD40303064 T8-40	T-8
SBRP4R 14 1T 14-160	1		14	14	160	4		
SBRP4R 15 1T 15-120	1		15	15	120	4		
SBRP4R 15 1T 15-150	1		15	15	150	4		
SBRP4R 15 1T 15-160	1		15	15	160	4		
SBRP4R 15 1T 15-200	1		15	15	200	4		
SBRP4R 16 2T 16-120	2		16	16	120	4		
SBRP4R 16 2T 16-150	2		16	16	150	4		
SBRP4R 16 2T 16-160	2		16	16	160	4		
SBRP4R 16 2T 16-200	2		16	16	200	4		
SBRP4R 20 2T 20-120	2		20	20	120	4		
SBRP4R 20 2T 20-150	2		20	20	150	4		
SBRP4R 20 2T 20-160	2		20	20	160	4		
SBRP4R 20 2T 20-200	2		20	20	200	4		
SBRP4R 25 3T 25-120	3		25	25	120	4		
SBRP4R 25 3T 25-150	3		25	25	150	4		
SBRP4R 25 3T 25-160	3		25	25	160	4		
SBRP4R 25 3T 25-200	3		25	25	200	4		
SBRP4R 25 3T 25-250	3		25	25	250	4		
SBRP5R 25 2T 25-120	2		RP10T3	25	25	120		
SBRP5R 25 2T 25-150	2	25		25	150	5		
SBRP5R 25 2T 25-160	2	25		25	160	5		
SBRP5R 25 2T 25-200	2	25		25	200	5		
SBRP5R 25 2T 25-250	2	25		25	250	5		

变杆铣刀SBRP系列
CUTTER BAR MILLER CUTTER SBRP SERIES

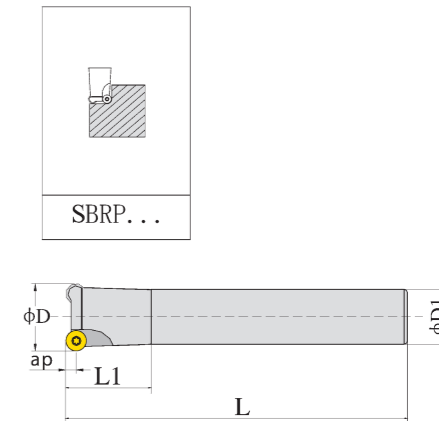

型号 Model	刃数 Blade number		D	D1	L	ap	螺丝 Screw	扳手 Wrench			
SBRP4R 17 1T 16-120	1	RP08T2	17	16	120	4	LD40303064 T8-40	T-8			
SBRP4R 17 1T 16-150	1		17	16	150	4					
SBRP4R 17 1T 16-160	1		17	16	160	4					
SBRP4R 17 1T 16-200	1		17	16	200	4					
SBRP4R 21 2T 20-120	2		21	20	120	4					
SBRP4R 21 2T 20-150	2		21	20	150	4					
SBRP4R 21 2T 20-160	2		21	20	160	4					
SBRP4R 21 2T 20-200	2		21	20	200	4					
SBRP4R 26 3T 25-120	3		26	25	120	4					
SBRP4R 26 3T 25-150	3		26	25	150	4					
SBRP4R 26 3T 25-160	3		26	25	160	4					
SBRP4R 26 3T 25-200	3		26	25	200	4					
SBRP4R 26 3T 25-250	3		26	25	250	4					
SBRP5R 26 2T 25-120	2		RP10T3	26	25	120			5	LD53273580 T15-45	T-15
SBRP5R 26 2T 25-150	2			26	25	150			5		
SBRP5R 26 2T 25-160	2	26		25	160	5					
SBRP5R 26 2T 25-200	2	26		25	200	5					
SBRP5R 26 2T 25-250	2	26	25	250	5						

A

铣刀系列
Milling cutter series

A

铣刀系列
Milling cutter series

直杆铣刀BRP/D系列
STRAIGHT BAR MILLER CUTTER BRP/D SERIES



型号 Model	刃数 Blade number		D	D1	L	ap	螺丝 Screw	扳手 Wrench	压板 Pressing plate				
BRP 4R 15 1T 15-120	1	RP08T2	15	15	120	4	LD40303064	T-8	R4YD				
BRP 4R 15 1T 15-160	1		15	15	160	4							
BRP 4R 15 1T 15-200	1		15	15	200	4							
BRP 4R 16 2T 16-120	2		16	16	120	4							
BRP 4R 16 2T 16-150	2		16	16	150	4							
BRP 4R 16 2T 16-160	2		16	16	160	4							
BRP 4R 16 2T 16-200	2		16	16	200	4							
BRP 4R 20 2T 20-120	2		20	20	120	4							
BRP 4R 20 2T 20-150	2		20	20	150	4							
BRP 4R 20 2T 20-160	2		20	20	160	4							
BRP 4R 20 2T 20-200	2		20	20	200	4							
BRP 4R 25 3T 25-120	3		25	25	120	4							
BRP 4R 25 3T 25-150	3		25	25	150	4							
BRP 4R 25 3T 25-160	3		25	25	160	4							
BRP 4R 25 3T 25-200	3		25	25	200	4							
BRP 4R 25 3T 25-250	3		25	25	250	4							
BRP 5R 16 1T 16-120	1		RP10T3	16	16	120				5	LD53273580	T-15	R5YD
BRP 5R 16 1T 16-150	1			16	16	150				5			
BRP 5R 16 1T 16-160	1			16	16	160				5			
BRP 5R 16 1T 16-200	1			16	16	200				5			
BRP 5R 20 1T 20-120	1	20		20	120	5							
BRP 5R 20 1T 20-150	1	20		20	150	5							
BRP 5R 20 1T 20-160	1	20		20	160	5							
BRP 5R 20 1T 20-200	1	20		20	200	5							
BRP 5R 25 2T 25-120	2	25		25	120	5							
BRP 5R 25 2T 25-150	2	25		25	150	5							
BRP 5R 25 2T 25-160	2	25		25	160	5							
BRP 5R 25 2T 25-200	2	25		25	200	5							
BRP 5R 25 2T 25-250	2	25		25	250	5							
BRP 5R 32 3T 32-160	3	32		32	160	5							
BRP 5R 32 3T 32-200	3	32		32	200	5							
BRP 5R 32 3T 32-250	3	32	32	250	5								
BRP 6R 25 2T 25-120	2	RP1204	25	25	120	6	LD57274010	T-15	R6YD				
BRP 6R 25 2T 25-150	2		25	25	150	6							
BRP 6R 25 2T 25-160	2		25	25	160	6							
BRP 6R 25 2T 25-200	2		25	25	200	6							
BRP 6R 25 2T 25-250	2		25	25	250	6							
BRP 6R 32 2T 32-160	2		32	32	160	6							
BRP 6R 32 2T 32-200	2		32	32	200	6							
BRP 6R 32 2T 32-250	2		32	32	250	6							

变杆铣刀BRP/D系列
CUTTER BAR MILLER CUTTER BRP/D SERIES

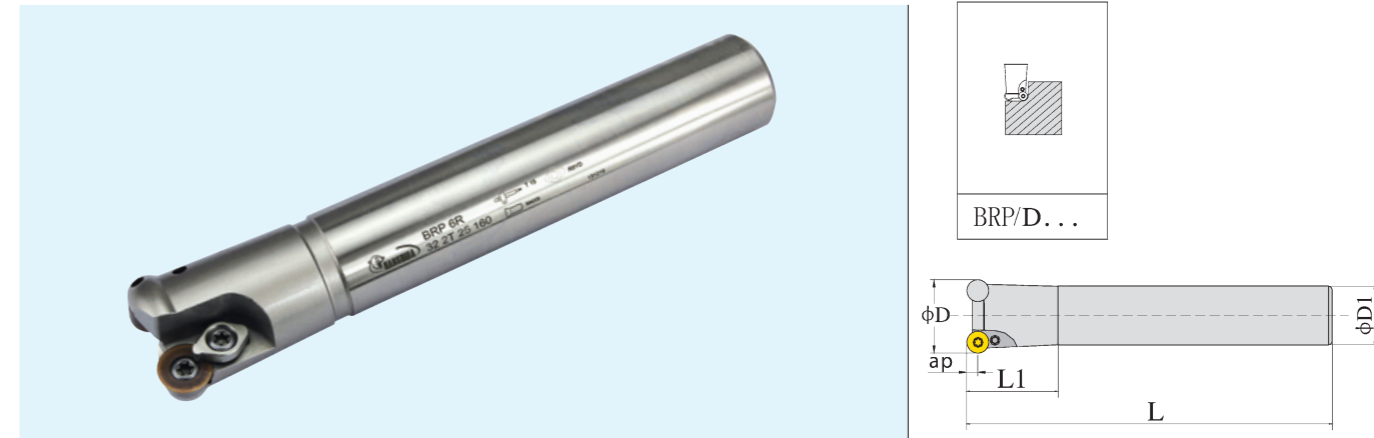

型号 Model	刃数 Blade number		D	D1	L	ap	螺丝 Screw	扳手 Wrench	压板 Pressing plate				
BRP/D4R 17 2T 16-120	2	RP08T2	17	16	120	4	LD40303064	T-10	R4YD				
BRP/D4R 17 2T 16-150	2		17	16	150	4							
BRP/D4R 17 2T 16-160	2		17	16	160	4							
BRP/D4R 17 2T 16-200	2		17	16	200	4							
BRP/D4R 21 2T 20-120	2		21	20	120	4							
BRP/D4R 21 2T 20-150	2		21	20	150	4							
BRP/D4R 21 2T 20-160	2		21	20	160	4							
BRP/D4R 21 2T 20-200	2		21	20	200	4							
BRP/D4R 26 3T 25-120	3		26	25	120	4							
BRP/D4R 26 3T 25-150	3		26	25	150	4							
BRP/D4R 26 3T 25-160	3		26	25	160	4							
BRP/D4R 26 3T 25-200	3		26	25	200	4							
BRP/D4R 26 3T 25-250	3		26	25	250	4							
BRP/D5R 17 1T 16-120	1		RP10T3	17	16	120				5	LD53273580	T-15	R5YD
BRP/D5R 17 1T 16-150	1			17	16	150				5			
BRP/D5R 17 1T 16-160	1	17		16	160	5							
BRP/D5R 17 1T 16-200	1	17		16	200	5							
BRP/D5R 21 2T 20-120	2	21		20	120	5							
BRP/D5R 21 2T 20-150	2	21		20	150	5							
BRP/D5R 21 2T 20-160	2	21		20	160	5							
BRP/D5R 21 2T 20-200	2	21		20	200	5							
BRP/D5R 26 2T 25-120	2	26		25	120	5							
BRP/D5R 26 2T 25-150	2	26		25	150	5							
BRP/D5R 26 2T 25-160	2	26		25	160	5							
BRP/D5R 26 2T 25-200	2	26		25	200	5							
BRP/D5R 26 2T 25-250	2	26		25	250	5							
BRP/D5R 32 3T 25-160	3	32		25	160	5							
BRP/D5R 32 3T 25-200	3	32		25	200	5							
BRP/D5R 32 3T 25-250	3	32	25	250	5								
BRP/D5R 35 3T 32-160	3	35	32	160	5								
BRP/D5R 35 3T 32-200	3	35	32	200	5								
BRP/D5R 35 3T 32-250	3	35	32	250	5								
BRP/D5R 40 3T 32-160	3	40	32	160	5								
BRP/D5R 40 3T 32-200	3	40	32	200	5								
BRP/D5R 40 3T 32-250	3	40	32	250	5								
BRP/D6R 26 2T 25-120	2	RP1204	26	25	120	6	LD57274010	T-15	R6YD				
BRP/D6R 26 2T 25-150	2		26	25	150	6							
BRP/D6R 26 2T 25-160	2		26	25	160	6							
BRP/D6R 26 2T 25-200	2		26	25	200	6							
BRP/D6R 26 2T 25-250	2		26	25	250	6							
BRP/D6R 32 3T 25-160	3		32	25	160	6							
BRP/D6R 32 3T 25-200	3		32	25	200	6							
BRP/D6R 32 3T 25-250	3		32	25	250	6							
BRP/D6R 35 3T 32-160	3		35	32	160	6							
BRP/D6R 35 3T 32-200	3		35	32	200	6							
BRP/D6R 35 3T 32-250	3		35	32	250	6							
BRP/D6R 40 3T 32-160	3		40	32	160	6							
BRP/D6R 40 3T 32-200	3	40	32	200	6								
BRP/D6R 40 3T 32-250	3	40	32	250	6								

A

铣刀系列
Milling cutter series

A

铣刀系列
Milling cutter series

BRP SBRP 刀盘系列
BRP SBRP CUTTER HEAD SERIES



型号 Model	刃数 Blade number		D	D1	L1	ap	螺丝 Screw	扳手 Wrench	压板 Pressing plate
BRP 5R 050 4T 22	1	RP10T3	50	22	45	5	LD53273580 T15-45	T-15	R5YD
BRP 5R 050 5T 22	1								
BRP 5R 063 4T 22	1								
BRP 5R 063 5T 22	1								
BRP 5R 080 5T 27	1								
BRP 5R 080 6T 27	1								
BRP 5R 100 6T 32	2								
BRP 5R 125 7T 40	2								
BRP 5R 160 8T 40	2								
BRP 6R 050 4T 22	2								
BRP 6R 050 5T 22	2	RP1204	50	22	45	6	LD57274010 T15-60	T-15	R6YD
BRP 6R 063 4T 22	2								
BRP 6R 063 5T 22	2								
BRP 6R 080 5T 27	2								
BRP 6R 080 6T 27	3								
BRP 6R 100 6T 32	3								
BRP 6R 125 7T 40	3								
BRP 6R 160 8T 40	3								

型号 Model	刃数 Blade number		D	D1	L1	ap	螺丝 Screw	扳手 Wrench
SBRP 5R 050 4T 22	4	RP10T3	50	22	45	5	LD53273580 T15-45	T-15
SBRP 5R 063 5T 22	5							
SBRP 5R 080 6T 27	6							
SBRP 5R 100 6T 32	6							

MFH01系列锁牙刀头
MFH01 SERIES OF LOCK TOOL HEAD

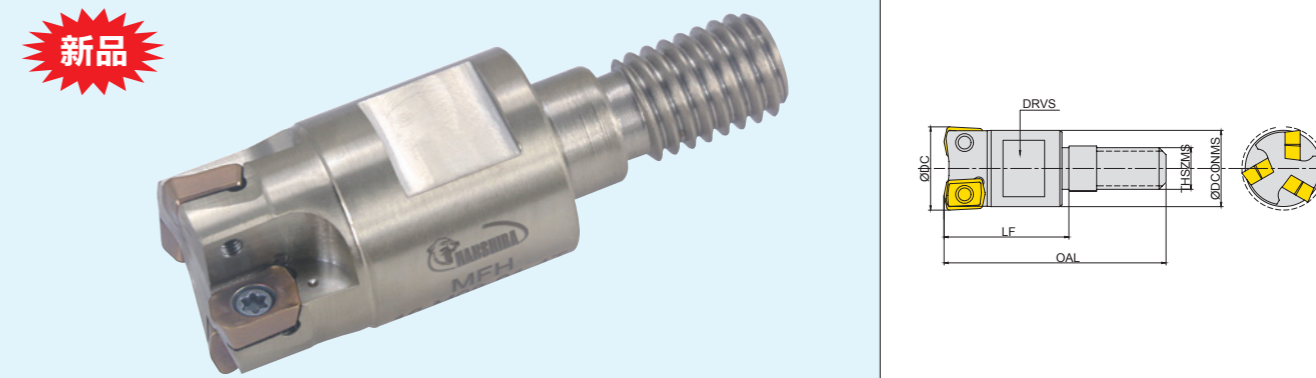

型号 Model		适用条件						螺丝 Screw	扳手 Wrench	
		刃数	ϕDc	$\phi DCONMS$	LF	OAL	THSZMS			DRVS
MFH 10-M05-01-2T	LPGT 010210ER 京瓷	2	10	09	17	29	M05	7	LD27281840 T6-22	T-6
MFH 11-M05-01-2T		2	11	09	17	29	M05	7		
MFH 12-M06-01-2T		3	12	11	17	32	M06	9		
MFH 13-M06-01-2T		3	13	11	17	32	M06	9		
MFH 14-M06-01-3T		3	14	13	17	32	M06	10		
MFH 15-M06-01-4T		4	15	13	17	32	M06	10		
MFH 16-M08-01-4T		4	16	15	25	43	M08	12		
MFH 17-M08-01-4T		4	17	15	25	43	M08	12		

MFH系列铣刀杆
MFH SERIES MILLING CUTTER BAR

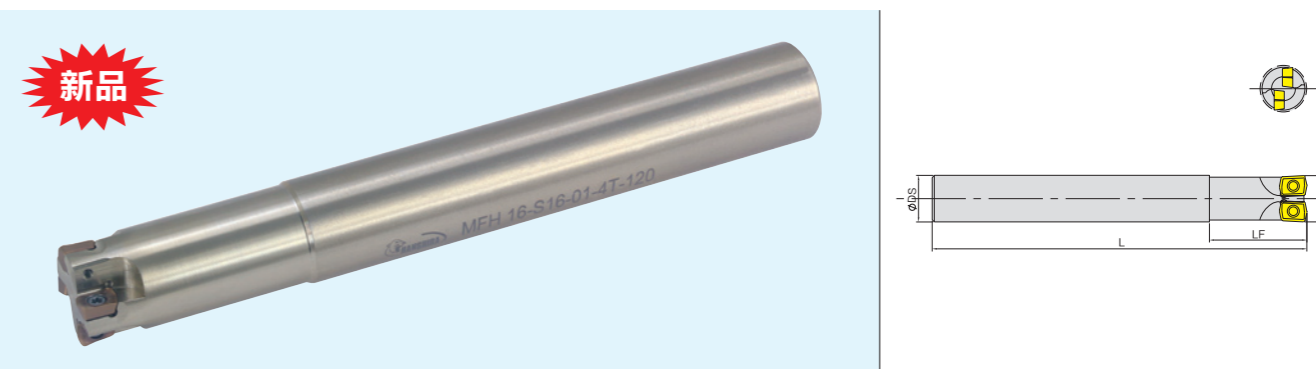

型号 Model		适用条件				螺丝 Screw	扳手 Wrench
		ϕDC	ϕDS	L	LF		
MFH 08-S10-01-1T	LPGT 010210ER 京瓷	8	10	80	17	LD27281840 T6-22	T-6
MFH 09-S10-01-1T		9	10	80	19		
MFH 10-S10-01-2T		10	10	80	22		
MFH 11-S10-01-2T		11	10	80	11		
MFH 12-S12-01-3T		12	12	80	26		
MFH 13-S12-01-3T		13	12	80	13		
MFH 14-S14-01-3T-120		14	14	120	30		
MFH 15-S16-01-4T-120		15	16	120	15		
MFH 16-S16-01-4T-120		16	16	120	35		

MFH03系列锁牙刀头
MFH03 SERIES OF LOCK TOOL HEAD

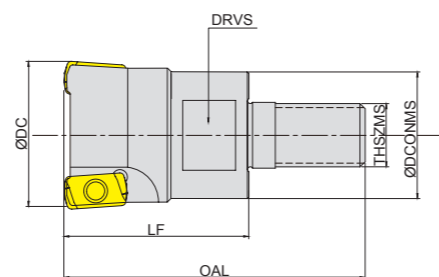
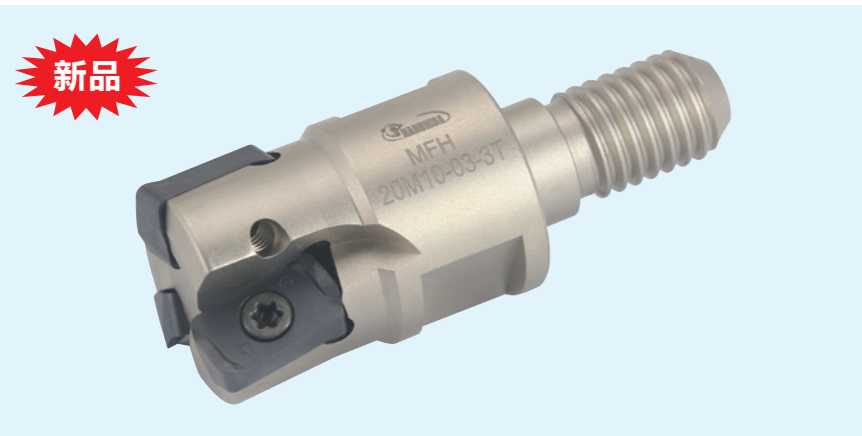

型号 Model	LOGU 03 京瓷	适用条件							螺丝 Screw	扳手 Wrench
		刃数	φDc	φDCONMS	LF	OAL	THSZMS	DRVS		
MFH 16-M08-03-2T	LOGU 03 京瓷	2	16	15	25	43	M08	12	LD40303064 T8-40	T-8
MFH 17-M08-03-2T		2	17	15	25	43	M08	12		
MFH 18-M08-03-2T		2	18	15	25	43	M08	12		
MFH 20-M10-03-3T		3	20	19	29	49	M10	15		
MFH 20-M10-03-4T		4	20	19	29	49	M10	15		
MFH 22-M10-03-3T		3	22	19	29	49	M10	15		
MFH 22-M10-03-4T		4	22	19	29	49	M10	15		
MFH 25-M12-03-4T		4	25	24	35	57	M12	19		
MFH 25-M12-03-5T		5	25	24	35	57	M12	19		
MFH 28-M12-03-4T		4	28	24	35	57	M12	19		
MFH 28-M12-03-5T		5	28	24	35	57	M12	19		
MFH 32-M16-03-5T		5	32	31	38	63	M16	24		
MFH 32-M16-03-6T		6	32	31	38	63	M16	24		

MFH03 系列铣刀杆
MFH03 SERIES MILLING CUTTER BAR

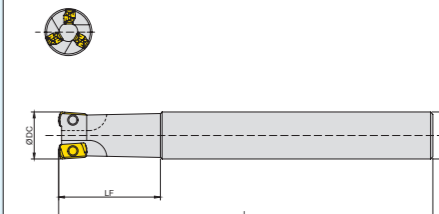
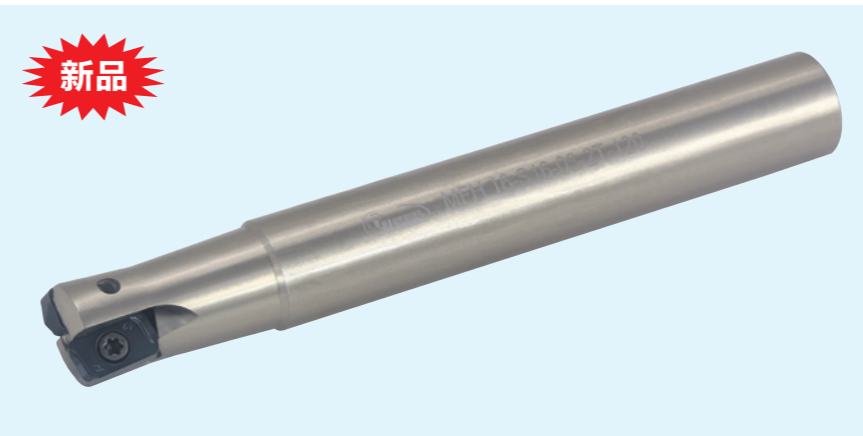

型号 Model	LOGU 03 京瓷	适用条件					螺丝 Screw	扳手 Wrench
		刃数	φDC	φDS	L	LF		
MFH16-S16-03-2T-100	LOGU 03 京瓷	2	16	16	100	35	LD40303064 T8-40	T-8
MFH16-S16-03-2T-120		2	16	16	120	35		
MFH16-S16-03-2T-160		2	16	16	160	35		
MFH17-S16-03-2T-100		2	17	16	100	17		
MFH17-S16-03-2T-120		2	17	16	120	17		
MFH17-S16-03-2T-160		2	17	16	160	17		
MFH18-S18-03-2T-160		2	18	18	160	39		
MFH19-S18-03-2T-160		2	19	18	160	19		
MFH20-S20-03-3T-120		3	20	20	120	44		
MFH20-S20-03-3T-160		3	20	20	160	44		
MFH20-S20-03-3T-200		3	20	20	200	44		
MFH21-S20-03-3T-120		3	21	20	120	21		
MFH21-S20-03-3T-160		3	21	20	160	21		
MFH21-S20-03-3T-200		3	21	20	200	21		
MFH22-S22-03-3T-160		3	22	22	160	48		
MFH23-S22-03-3T-160		3	23	22	160	23		
MFH25-S25-03-4T-120		4	25	25	120	55		
MFH25-S25-03-4T-160		4	25	25	160	55		
MFH25-S25-03-4T-200		4	25	25	200	55		
MFH26-S25-03-4T-120		4	26	25	120	26		
MFH26-S25-03-4T-160		4	26	25	160	26		
MFH26-S25-03-4T-200		4	26	25	200	26		
MFH28-S25-03-4T-160		4	28	25	160	28		
MFH30-S25-03-5T-160		5	30	25	160	30		
MFH32-S32-03-5T-120		5	32	32	120	64		
MFH32-S32-03-5T-160		5	32	32	160	70		
MFH32-S32-03-5T-200		5	32	32	200	70		
MFH33-S32-03-5T-160		5	33	32	160	33		
MFH33-S32-03-5T-200		5	33	32	200	33		

A

铣刀系列
Milling cutter series

A

铣刀系列
Milling cutter series

MFH03 高进给刀杆刀盘系列
MFH03 HIGH FEED CUTTER HEAD SERIES

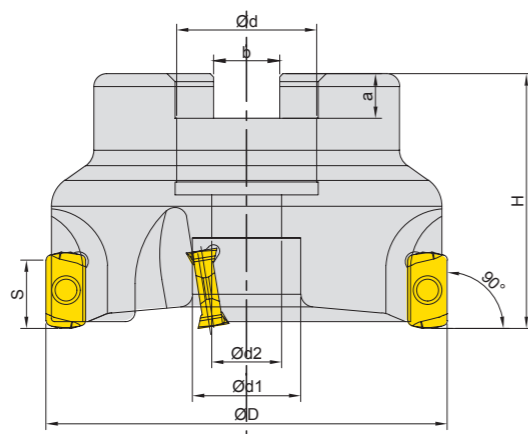
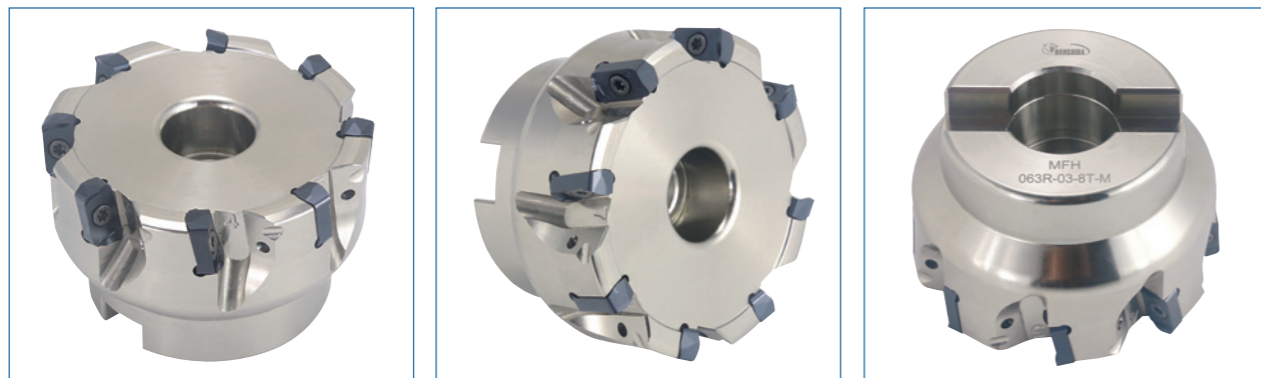

型号 Model		适用条件								螺丝 Screw	扳手 Wrench	
		刃数	ϕD	ϕd	$\phi d1$	$\phi d2$	H	S	b			a
MFH 035R-03-16-5T-M	LOGU 03 京瓷	5	35	16	14	9	40	9	8.4	7	LD40303064 T8-40	T-8
MFH 040R-03-16-6T-M		6	40	16	14	9	40	9	8.4	7		
MFH 050R-03-22-8T-M		8	50	22	17	11	40	9	10.4	7		
MFH 063R-03-22-8T-M		8	63	22	17	11	40	9	10.4	7		
MFH 080R-03-27-10T-M		10	80	27	34	13	40	9	12.4	7		
MFH 100R-03-32-12T-M		12	100	32	42	17	50	9	14.4	9		

MFH10系列锁牙刀头
MFH10 SERIES OF LOCK TOOL HEAD

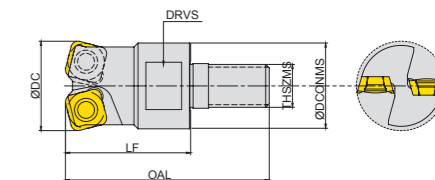
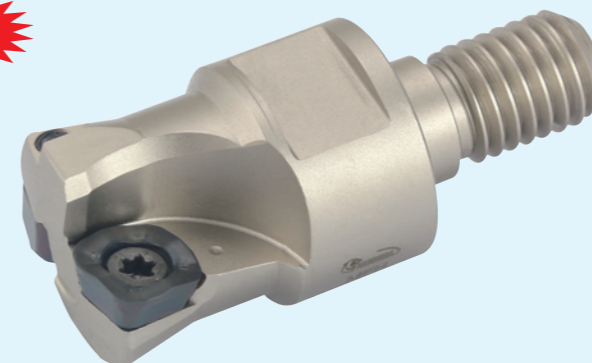

型号 Model		适用条件							螺丝 Screw	扳手 Wrench
		刃数	ϕDc	$\phi DCNMS$	LF	OAL	THSZMS	DRVS		
MFH 20-M10-10-1T	SOMT1004 京瓷	1	20	19	29	49	M10	15	LD55294010 T15-60	T-15
MFH 21-M10-10-1T		1	21	19	29	49	M10	15		
MFH 25-M12-10-2T		2	25	24	35	57	M12	19		
MFH 26-M12-10-2T		2	26	24	35	57	M12	19		
MFH 32-M16-10-3T		3	32	31	38	63	M16	24		
MFH 33-M16-10-3T		3	33	31	38	63	M16	24		
MFH 35-M16-10-3T		3	35	31	38	63	M16	24		

MFH10系列铣刀杆
MFH10 SERIES MILLING CUTTER BAR

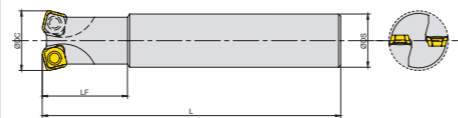
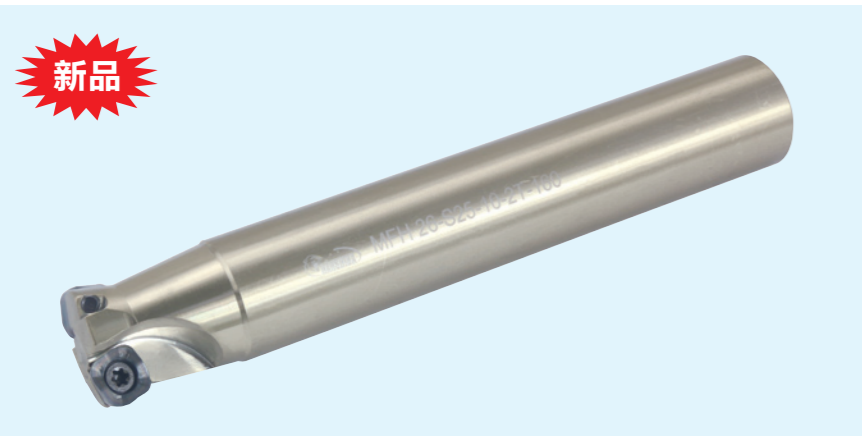

型号 Model		适用条件					螺丝 Screw 	扳手 Wrench
		刃数	φDC	φDS	L	LF		
MFH25-S25-10-2T-120	SOMT1004 京瓷	2	25	25	120	55	LD55294010 T15-60	T-15
MFH25-S25-10-2T-160		2	25	25	160	55		
MFH25-S25-10-2T-200		2	25	25	200	55		
MFH26-S25-10-2T-160		2	26	25	160	26		
MFH26-S25-10-2T-200		2	26	25	200	26		
MFH32-S32-10-3T-120		3	32	32	120	60		
MFH32-S32-10-3T-160		3	32	32	160	70		
MFH32-S32-10-3T-200		3	32	32	200	70		
MFH33-S32-10-3T-160		3	33	32	160	33		
MFH33-S32-10-3T-200		3	33	32	200	33		

MFH高进给刀杆刀盘系列
MFH HIGH FEED CUTTER HEAD SERIES



图1



图2

型号 Model		适用条件										螺丝 Screw 	扳手 Wrench
		刃数	φD	φd	φd1	φd2	H	S	b	a	形状		
MFH 040R-10-5T	SOMT1004 京瓷	5	40	16	9	17	40	1	8.4	7	图1	LD55294010 T15-60	T-15
MFH 050R-10-5T		5	50	22	11	17	40	1	10.4	7	图1		
MFH 063R-10-6T		6	63	22	11	34	40	1	10.4	7	图1		
MFH 080R-10-7T		7	80	27	13	42	50	1	12.4	7	图1		
MFH 050R-14-4T	SOMT1405 京瓷	4	50	22	11	15	40	1.5	10.4	7	图1	LD70275012 T20-70	T-20
MFH 063R-14-5T		5	63	22	11	17	40	1.5	10.4	7	图1		
MFH 080R-14-6T		6	80	27	13	32	50	1.5	12.4	7	图1		
MFH 100R-14-7T		7	100	32	17	42	50	1.5	14.4	9	图1		
MFH 125R-14-8T		8	125	40	55	-	55	1.5	16.4	9	图2		
MFH 160R-14-8T	8	160	40	90	-	55	1.5	16.4	9	图2			

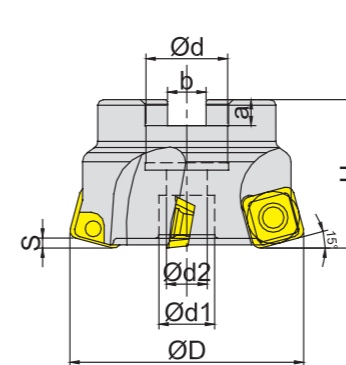
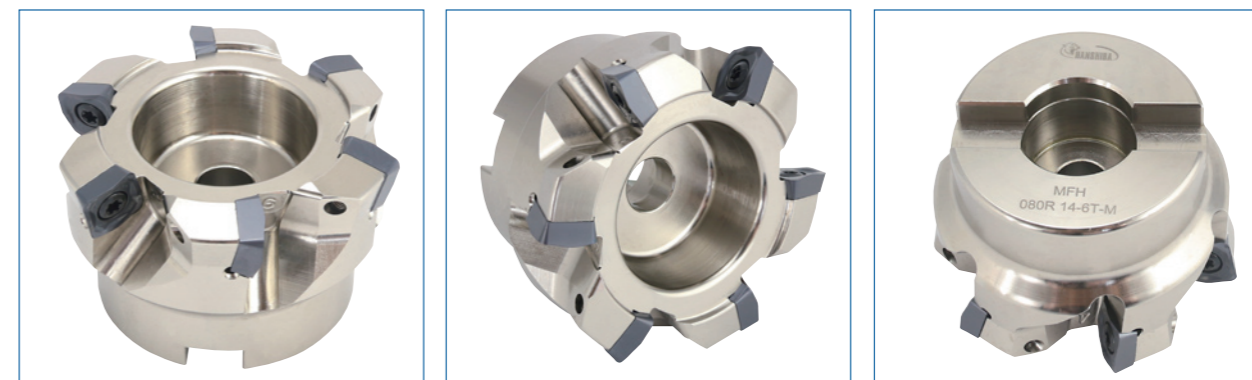
A

铣刀系列
Milling cutter series

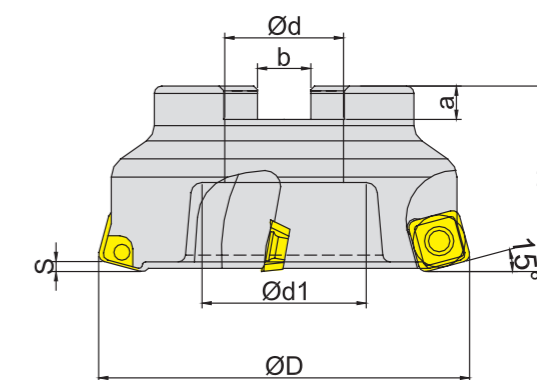
A

铣刀系列
Milling cutter series

EXN02 03系列锁牙刀头
EXN02 03 SERIES OF LOCK TOOL HEAD

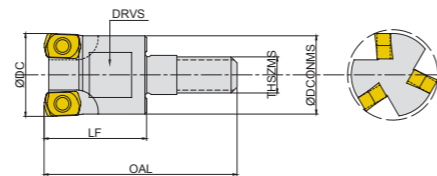
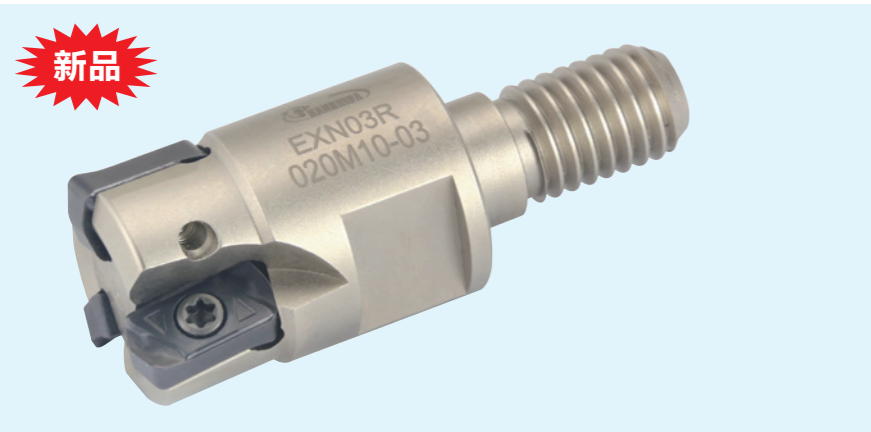

型号 Model		适用条件							螺丝 Screw	扳手 Wrench
		刃数	φDc	φDCONMS	LF	OAL	THSZMS	DRVS		
EXN02R08M04-01	LNMU02	1	8	7.8	17	28	M04	7	LD25261837 T6-20	T-6
EXN02R09M04-01		1	9	7.8	17	28	M04	7		
EXN02R010M05-02		2	10	9	17	29	M05	7		
EXN02R011M05-02		2	11	9	17	29	M05	7		
EXN02R012M06-03		3	12	11	17	32	M06	9		
EXN02R013M06-03		3	13	11	17	32	M06	9		
EXN02R014M06-03		3	14	13	17	32	M06	10		
EXN02R015M06-03		3	15	13	17	32	M06	10		
EXN02R016M08-04		4	16	15	25	43	M08	12		
EXN02R017M08-04		4	17	15	25	43	M08	12		
EXN03R016M08-02	LNMU03	2	16	15	25	43	M08	12	LD36272570 T8-42	T-8
EXN03R017M08-02		2	17	15	25	43	M08	12		
EXN03R018M08-02		2	18	15	25	43	M08	12		
EXN03R020M10-03		3	20	19	29	49	M10	15		
EXN03R021M10-03		3	21	19	29	49	M10	15		
EXN03R022M10-03		3	22	19	29	49	M10	15		
EXN03R025M12-04		4	25	24	35	57	M12	19		
EXN03R026M12-04		4	26	24	35	57	M12	19		
EXN03R028M12-05		5	28	24	35	57	M12	19		
EXN03R032M16-05		5	32	31	38	63	M16	24		
EXN03R035M16-06	6	35	31	38	63	M16	24			

EXN02 03系列铣刀杆
EXN02 03 SERIES MILLING CUTTER BAR

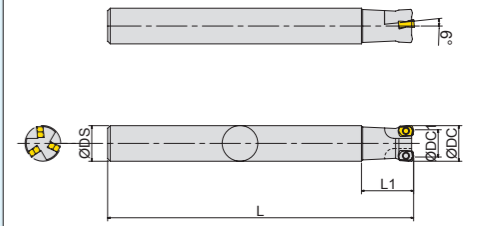
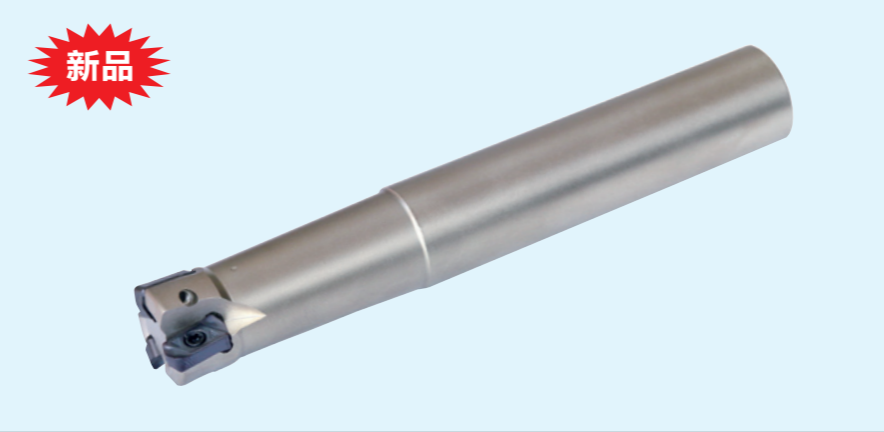

型号 Model		适用条件						螺丝 Screw	扳手 Wrench			
		刃数	φDc	φDc1	φDs	L	L1					
EXN02R08M10.0-100-01	LNMU02	1	8	3.61	10	100	17	LD25261837 T6-20	T-6			
EXN02R09M10.0-100-01		1	9	4.74	10	100	19					
EXN02R010M10.0-100-02		2	10	5.85	10	100	22					
EXN02R011M10.0-100-02		2	11	6.76	10	100	11					
EXN02R012M12.0-80-03		3	12	7.68	12	80	26					
EXN02R012M12.0-120-03		3	12	7.68	12	120	26					
EXN02R013M12.0-80-03		3	13	8.68	12	80	13					
EXN02R013M12.0-120-03		3	13	8.68	12	120	13					
EXN02R014M14.0-120-03		3	14	9.51	14	120	30					
EXN02R014M14.0-150-03		3	14	9.51	14	150	30					
EXN02R015M14.0-120-03		3	15	10.43	14	120	15					
EXN02R015M14.0-160-03		3	15	10.43	14	160	15					
EXN02R016M16.0-120-04		4	16	11.35	16	120	35					
EXN02R016M16.0-160-04		4	16	11.35	16	160	35					
EXN02R017M16.0-120-04		4	17	12.27	16	120	17					
EXN02R017M16.0-160-04		4	17	12.27	16	160	17					
EXN03R016M16.0-100-02		LNMU03	2	16	10.18	16	100			30	LD36272570 T8-42	T-8
EXN03R016M16.0-120-02			2	16	10.18	16	120			30		
EXN03R016M16.0-150-02			2	16	10.18	16	150			30		
EXN03R017M16.0-100-02			2	17	11.18	16	100			20		
EXN03R017M16.0-120-02	2		17	11.18	16	120	20					
EXN03R017M16.0-150-02	2		17	11.18	16	150	20					
EXN03R020M20.0-100-03	3		20	14.18	20	100	30					
EXN03R020M20.0-130-03	3		20	14.18	20	130	50					
EXN03R020M20.0-160-03	3		20	14.18	20	160	50					
EXN03R021M20.0-130-03	3		21	15.18	20	130	35					
EXN03R021M20.0-160-03	3		21	15.18	20	160	35					
EXN03R025M25.0-100-04	4		25	19.18	25	100	37					
EXN03R025M25.0-140-04	4		25	19.18	25	140	60					
EXN03R025M25.0-200-04	4		25	19.18	25	200	60					
EXN03R026M25.0-140-04	4		26	20.18	25	140	30					
EXN03R026M25.0-200-04	4		26	20.18	25	200	30					
EXN03R030M25.0-150-04	4		30	24.18	25	150	30					
EXN03R032M32.0-150-05	5		32	26.18	32	150	70					
EXN03R032M32.0-200-05	5		32	26.18	32	200	70					
EXN03R033M32.0-150-05	5		33	27.18	32	150	30					
EXN03R033M32.0-200-05	5	33	27.18	32	200	30						
EXN03R035M32.0-160-06	6	35	29.18	32	160	40						
EXN03R035M32.0-200-06	6	35	29.18	32	200	40						

A

铣刀系列
Milling cutter series

A

铣刀系列
Milling cutter series

TXN高进给刀杆刀盘系列
TXN HIGH FEED ROD AND DISC SERIES

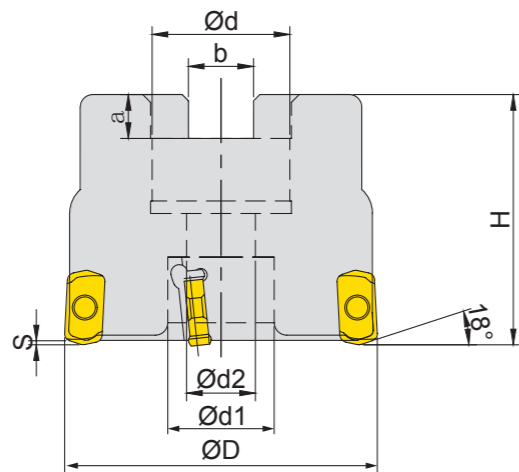
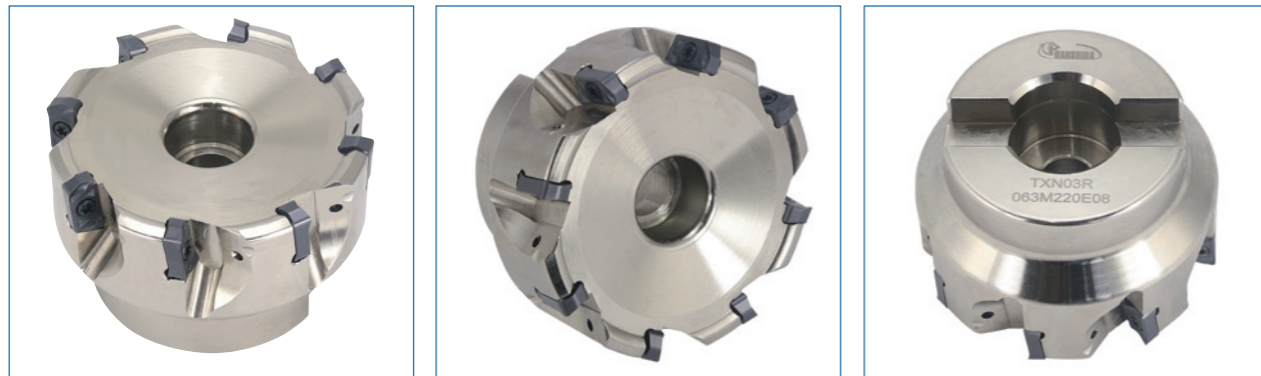

型号 Model		适用条件									螺丝 Screw	扳手 Wrench			
		刃数	φD	φd	φd1	φd2	H	S	b	a					
TXN03R032M160E06	LNMU03	6	32	16	14	9	40	0.5	8.4	6	LD36272570 T8-42	T-8			
TXN03R032M160E06-A		6	32	16	14	9	40	0.5	8.4	6					
TXN03R035M160E06		6	35	16	14	9	40	0.5	8.4	6					
TXN03R035M160E06-A		6	35	16	14	9	40	0.5	8.4	6					
TXN03R040M160E06		6	40	16	14	9	40	0.5	8.4	6					
TXN03R040M160E06-A		6	40	16	14	9	40	0.5	8.4	6					
TXN03R045M160E06		6	45	16	14	9	40	0.5	8.4	6					
TXN03R045M160E06-A		6	45	16	14	9	40	0.5	10.4	7					
TXN03R050M220E08		8	50	22	17	11	40	0.5	10.4	7					
TXN03R050M220E08-A		8	50	22	17	11	40	0.5	10.4	7					
TXN03R055M220E08		8	55	22	17	11	40	0.5	10.4	7					
TXN03R055M220E08-A		8	55	22	17	11	40	0.5	10.4	7					
TXN03R063M220E08		8	63	22	17	11	40	0.5	10.4	7					
TXN03R063M220E08-A		8	63	22	17	11	40	0.5	10.4	7					
TXN03R070M220E10		10	70	22	17	11	40	0.5	10.4	7					
TXN03R070M220E10-A		10	70	22	17	11	40	0.5	10.4	7					
TXN03R080M270E10		10	80	27	34	13	50	0.5	12.4	9					
TXN03R080M270E10-A		10	80	27	34	13	50	0.5	12.4	9					
TXN06R050M220E05		LNMU06	5	50	22	17	11	40	0.5	10.4			7	LD70275012 T20-70	T-20
TXN06R063M220E06			6	63	22	17	11	40	0.5	10.4			7		
TXN06R080M270E08	8		80	27	34	13	50	0.5	12.4	9					

TEBL 04 06系列锁牙刀头
TEBL 04 06 SERIES OF LOCK TOOL HEAD

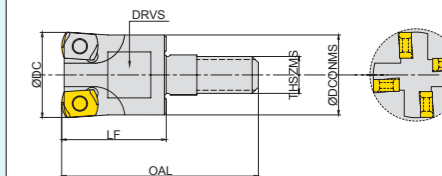

型号 Model		适用条件							螺丝 Screw	扳手 Wrench
		刃数	φDc	φDCONMS	LF	OAL	THSZMS	DRVS		
TEBL-108-M04-04	BLMP0402	1	8	7.8	17	28	M04	7	LD25261837 T6-20	T-6
TEBL-109-M04-04		1	9	7.8	17	28	M04	7		
TEBL-210-M05-04		2	10	9	17	29	M05	7		
TEBL-211-M05-04		2	11	9	17	29	M05	7		
TEBL-312-M06-04		3	12	11	17	32	M06	9		
TEBL-313-M06-04		3	13	11	17	32	M06	9		
TEBL-414-M06-04		4	14	13	17	32	M06	10		
TEBL-415-M06-04		4	15	13	17	32	M06	10		
TEBL-416-M08-04		4	16	15	25	43	M08	12		
TEBL-417-M08-04		4	17	15	25	43	M08	12		
TEBL-216-M08-06		2	16	15	25	43	M08	12		
TEBL-217-M08-06		2	17	15	25	43	M08	12		
TEBL-218-M08-06		2	18	15	25	43	M08	12		
TEBL-320-M10-06		3	20	19	29	49	M10	15		
TEBL-321-M10-06	3	21	19	29	49	M10	15			
TEBL-425-M12-06	4	25	24	35	57	M12	19			
TEBL-426-M12-06	4	26	24	35	57	M12	19			
TEBL-430-M16-06	4	30	29	38	63	M16	24			
TEBL-532-M16-06	5	32	31	38	63	M16	24			
TEBL-533-M16-06	5	33	31	38	63	M16	24			

TEBL04 06系列铣刀杆
TEBL04 06 SERIES MILLING CUTTER BAR

新品

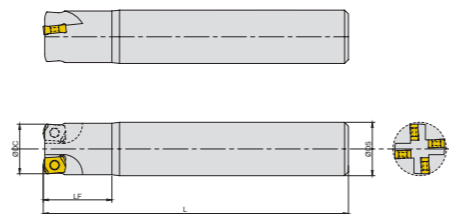
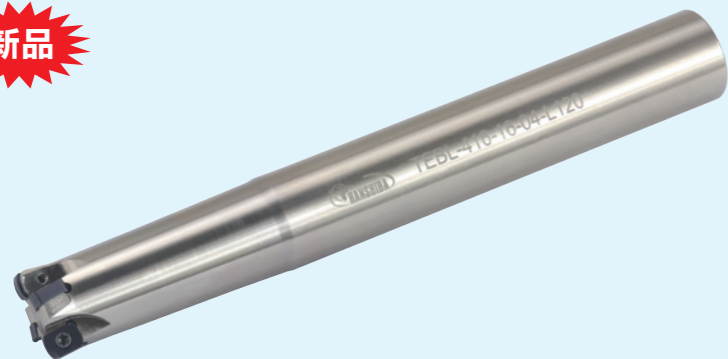

A

铣刀系列
Milling cutter series

型号 Model		适用条件					螺丝 Screw	扳手 Wrench
		刃数	φDC	φDS	L	LF		
TEBL-107-10-04-L80	BLMP0402	1	7	10	80	15	LD25261837 T6-20	T-6
TEBL-108-10-04-L80		1	8	10	80	17		
TEBL-109-10-04-L80		1	9	10	80	19		
TEBL-210-10-04-L80		2	10	10	80	22		
TEBL-211-10-04-L80		2	11	10	80	11		
TEBL-312-12-04-L80		3	12	12	80	26		
TEBL-313-12-04-L80		3	13	12	80	13		
TEBL-314-14-04-L100		3	14	14	100	30		
TEBL-315-14-04-L100		3	15	14	100	15		
TEBL-416-16-04-L120		4	16	16	120	35		
TEBL-417-16-04-L120		4	17	16	120	17		
TEBL-216-16-06-L 120		2	16	16	120	35		
TEBL-217-16-06-L 160		2	17	16	160	17		
TEBL-320-20-06-L 120		3	20	20	120	44		
TEBL-320-20-06-L 160		3	20	20	160	44		
TEBL-321-20-06-L 160	3	21	20	160	21			
TEBL-321-20-06-L 200	3	21	20	200	21			
TEBL-425-25-06-L 160	3	25	25	160	55			
TEBL-425-25-06-L 200	4	25	25	200	55			
TEBL-426-25-06-L 160	4	26	25	160	26			
TEBL-426-25-06-L 200	4	26	25	200	26			
TEBL-430-28-06-L 160	4	30	28	160	30			
TEBL-532-32-06-L 160	5	32	32	160	70			
TEBL-532-32-06-L 200	5	32	32	200	70			
TEBL-533-32-06-L 160	5	33	32	160	33			
TEBL-533-32-06-L 160	5	33	32	200	33			

TEMBL 刀盘系列
TEMBL CUTTER HEAD SERIES

新品

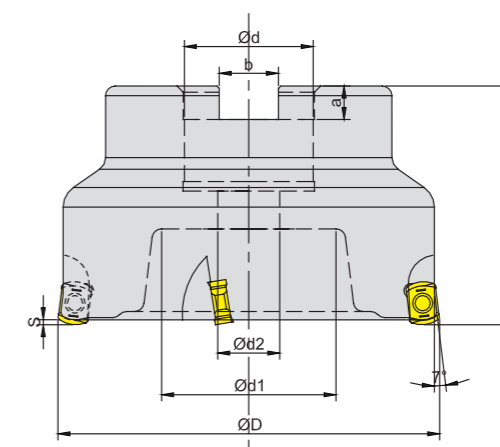
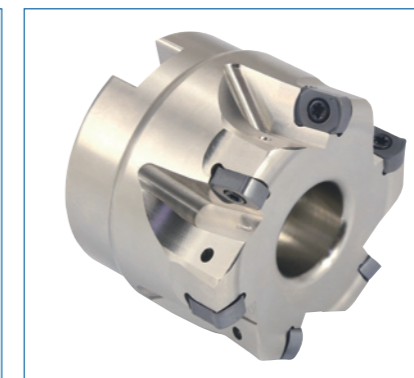

型号 Model		适用条件									螺丝 Screw	扳手 Wrench
		刃数	φD	φd	φd1	φd2	H	S	b	a		
TEMBL-435-16R-06	BLMP0603	4	35	16	14	9	40	1	8.4	7	LD36272570 T8-42	T-8
TEMBL-540-16R-06		5	40	16	14	9	40	1	8.4	7		
TEMBL-650-22R-06		6	50	22	17	11	40	1	10.4	7		
TEMBL-863-22R-06		8	63	22	17	11	40	1	10.4	7		
TEMBL-1080-27R-06		10	80	27	34	13	50	1	12.4	7		

A

铣刀系列
Milling cutter series

SDMT1205/1505高进给刀盘系列
SDMT1205/1505 HIGH INTAKE CUTTER HEAD SERIES

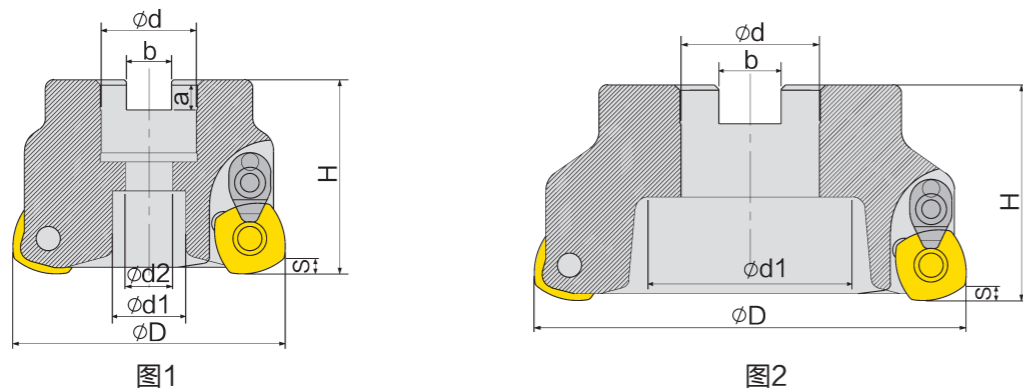

型号 Model		适用条件									螺丝 Screw	压板 Press plate	扳手 Wrench	
		刃数	φD	φd	φd1	φd2	H	S	b	a				形状
ASRF 12 050 4T 22	SDMT120512	4	50	22	17	11	45	2	10.4	7	图1	LD57294010	CYB1610-4	T-15
ASRF 12 063 4T 22		4	63	22	17	11	45	2	10.4	7	图1			
ASRF 12 080 5T 27		5	80	27	30	13	50	2	12.4	7	图1			
ASRF 12 100 6T 32		6	100	32	47	-	50	2	14.4	9	图2			
ASRF 12 125 7T 40		7	125	40	55.5	-	55	2	16.4	9	图2			
ASRF 12 160 8T 40		8	160	40	90.5	-	55	2	16.4	9	图2			
ASRF 15 050 4T 22	SDMT150512	4	50	22	17	11	45	3	10.4	7	图1	LD70275012	CYB1610-5	T-20
ASRF 15 063 4T 22		4	63	22	17	11	45	3	10.4	7	图1			
ASRF 15 080 5T 27		5	80	27	30	13	50	3	12.4	7	图1			
ASRF 15 100 6T 32		6	100	32	47	-	50	3	14.4	9	图2			
ASRF 15 125 7T 40		7	125	40	55.5	-	55	3	16.4	9	图2			
ASRF 15 160 8T 40		8	160	40	90.5	-	55	3	16.4	9	图2			

AP 玉米刀盘系列
AP CORN KNIFE PLATE SERIES

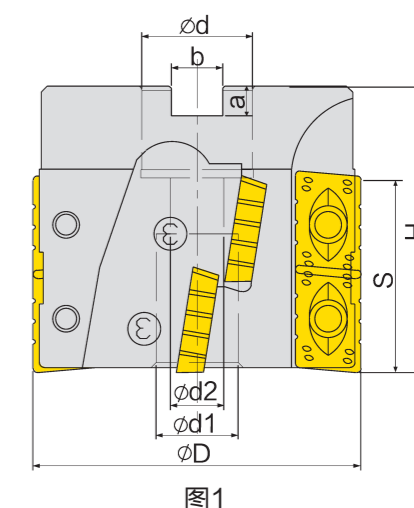
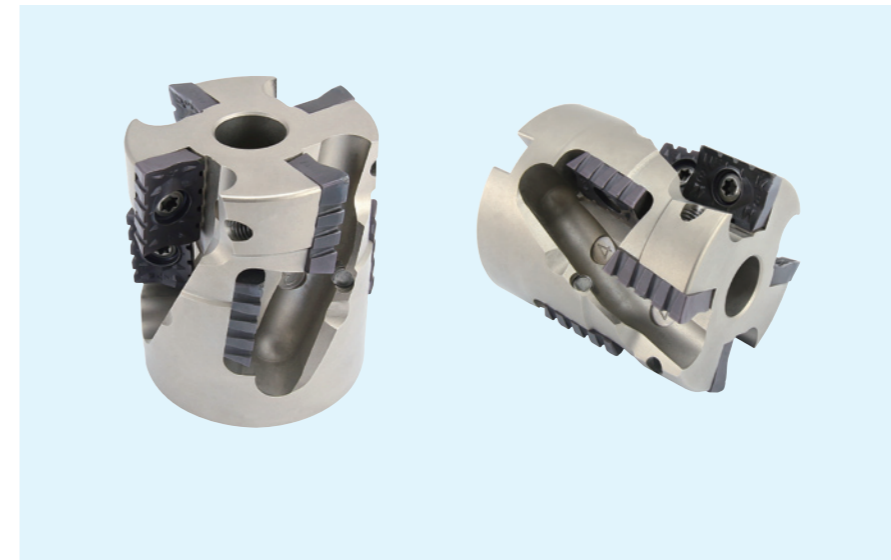

型号 Model		适用条件									螺丝 Screw	扳手 Wrench	
		刃数	φD	φd	φd1	φd2	H	S	b	a			形状
MSR063 45 22 3T JC	APMT 2506**ER-NB3	4	63	22	17	11	70	45	10.4	7	图1	LD80306015	T-25
MSR080 45 27 4T JC		4	80	27	20	13	70	45	12.4	7	图1		
MSR100 45 32 6T JC		6	100	32	25	17	70	45	14.4	9	图1		

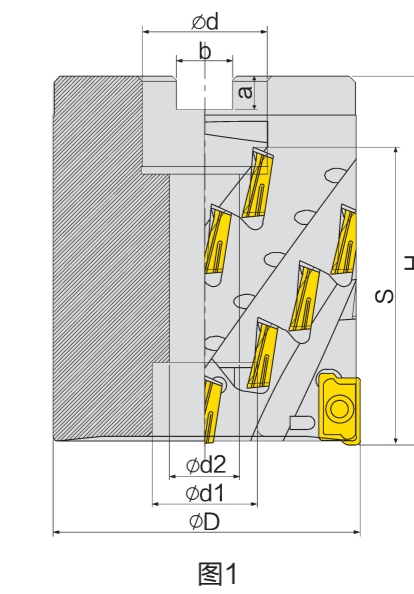
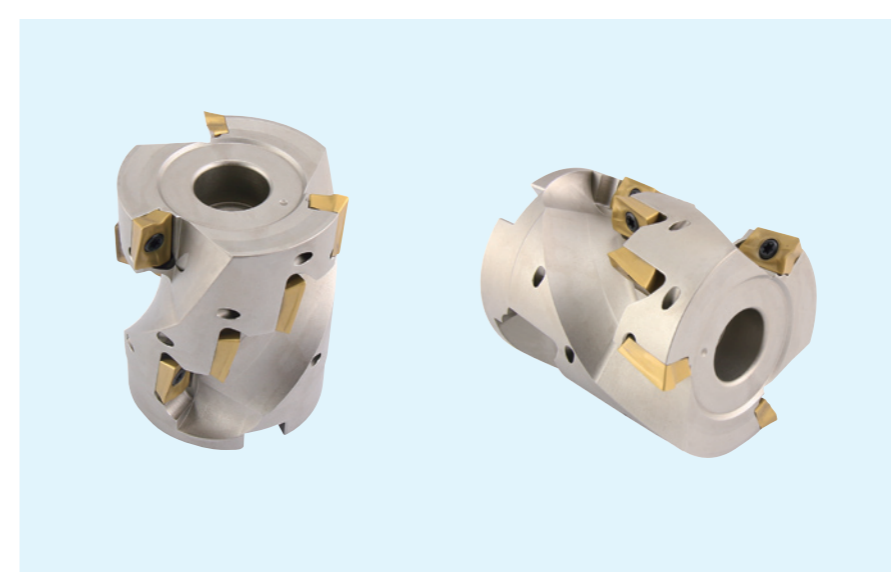

型号 Model		适用条件									螺丝 Screw	扳手 Wrench	
		刃数	φD	φd	φd1	φd2	H	S	b	a			形状
YMC050-AP17-58-22-3/12T	APMT 1705 特固克	3	50	22	17	11	75	58	10.4	7	图1	LD57294010	T-15
YMC063-AP17-58-22-3/12T		3	63	22	17	11	75	58	10.4	7	图1		
YMC063-AP17-58-22-4/16T		4	63	22	17	11	75	58	10.4	7	图1		
YMC080-AP17-76-27-5/25T		5	80	27	20	13	95	76	12.4	7	图1		
YMC100-AP17-76-32-6/30T		6	100	32	25	17	95	76	14.4	9	图1		

A

铣刀系列
Milling cutter series

A

铣刀系列
Milling cutter series

BAP直杆玉米铣刀杆
BAP STRAIGHT CORN MILLING CUTTER SHANK

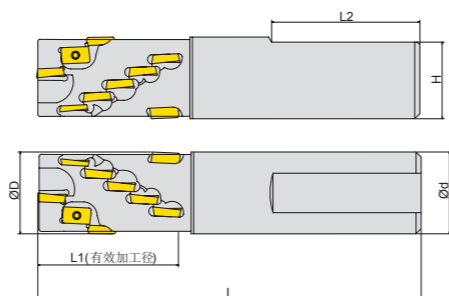

型号 Model		适用条件							螺丝 Screw	扳手 Wrench			
		刃数	ϕD	ϕd	L	L1	L2	H					
BAP300R-C20-19-26M-120-2T-6P	AP1135	6	19	20	120	26	58	23	LD35212550 T8-30	T-8			
BAP300R-C20-20-26M-120-2T-6P		6	20	20	120	26	58	23					
BAP300R-C20-19-44M-130-2T-10P		10	19	20	130	44	58	23					
BAP300R-C20-20-44M-130-2T-10P		10	20	20	130	44	58	23					
BAP300R-C20-19-70M-150-2T-16P		16	19	20	150	70	58	23					
BAP300R-C20-20-70M-150-2T-16P		16	20	20	150	70	58	23					
BAP300R-C25-24-35M-130-2T-8P		8	24	25	130	35	58	23					
BAP300R-C25-25-35M-130-2T-8P		8	25	25	130	35	58	23					
BAP300R-C25-24-44M-130-2T-10P		10	24	25	130	44	58	23					
BAP300R-C25-25-44M-130-2T-10P		10	25	25	130	44	58	23					
BAP300R-C25-24-70M-150-2T-16P		16	24	25	150	70	58	23					
BAP300R-C25-25-70M-150-2T-16P		16	25	25	150	70	58	23					
BAP300R-C32-31-44M-150-3T-15P		15	31	32	150	44	58	30					
BAP300R-C32-32-44M-150-3T-15P		15	32	32	150	44	58	30					
BAP400R-C32-31-41M-150-2T-6P		AP1604	6	31	32	150	41	58			30	LD57294010 T15-60	T-15
BAP400R-C32-32-41M-150-2T-6P			6	32	32	150	41	58			30		
BAP400R-C32-31-69M-150-2T-10P	10		31	32	150	69	58	30					
BAP400R-C32-32-69M-150-2T-10P	10		32	32	150	69	58	30					
BAP400R-C32-34-55M-150-2T-8P	8		34	32	150	55	58	30					
BAP400R-C32-35-55M-150-2T-8P	8		35	32	150	55	58	30					
BAP400R-C32-34-69M-150-2T-10P	10		34	32	150	69	58	30					
BAP400R-C32-35-69M-150-2T-10P	10		35	32	150	69	58	30					
BAP400R-C32-39-69M-150-3T-15P	15		39	32	150	69	58	37					
BAP400R-C32-40-69M-150-3T-15P	15		40	32	150	69	58	37					
BAP400R-C32-39-97M-200-3T-21P	21		39	32	200	97	108	37					
BAP400R-C32-40-97M-200-3T-21P	21		40	32	200	97	108	37					

BAP套式玉米铣刀盘
BAP NESTED CORN MILLING CUTTER DISC

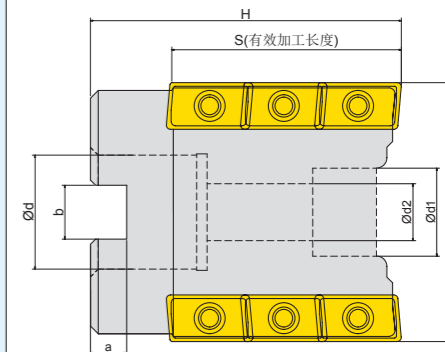
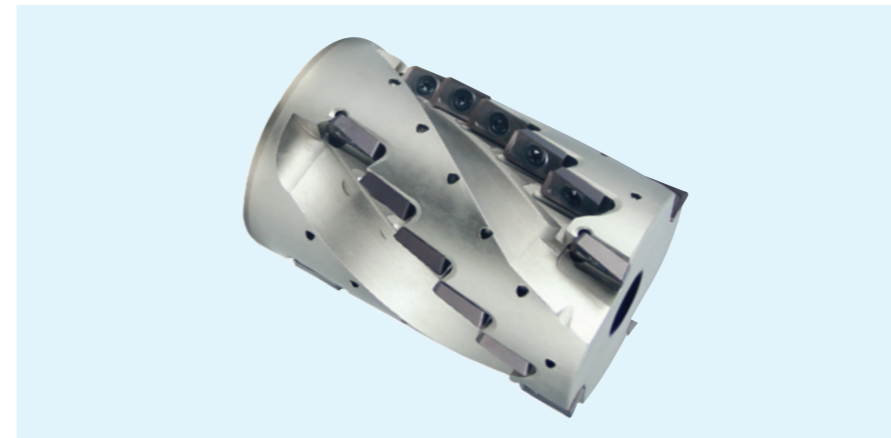

型号 Model		适用条件									螺丝 Screw	扳手 Wrench
		刃数	ϕD	ϕd	$\phi d1$	$\phi d2$	H	S	b	a		
BAP400R-50-22-42M-4T-12P	AP1604	12	50	22	17	11	60	42	10.4	7	LD57294010 T15-60	T-15
BAP400R-50-22-60M-4T-16P		16	50	22	17	11	75	60	10.4	7		
BAP400R-63-27-42M-4T-12P		12	63	27	20	14	60	42	12.4	7		
BAP400R-63-27-60M-4T-16P		16	63	27	20	14	75	60	12.4	7		
BAP400R-80-32-70M-5T-25P		25	80	32	27	18	95	72	14.4	9		
BAP400R-100-40-72M-6T-30P		30	100	40	32	22	110	72	16.4	9		

型号 Model		适用条件									螺丝 Screw	扳手 Wrench
		刃数	ϕD	ϕd	$\phi d1$	$\phi d2$	H	S	b	a		
BAP400R-50-22-70M-4T-20P	AP1604	20	50	22	17	11	90	70	10.4	7	LD57294010 T15-60	T-15
BAP400R-50-22-100M-4T-28P		28	50	22	17	11	120	100	10.4	7		
BAP400R-63-27-70M-4T-20P		20	63	27	20	14	90	70	12.4	7		
BAP400R-63-27-100M-4T-28P		28	63	27	20	14	120	100	12.4	7		
BAP400R-80-32-80M-5T-30P		30	80	32	27	18	110	80	14.4	9		
BAP400R-80-32-120M-5T-36P		36	80	32	27	18	150	120	14.4	9		
BAP400R-100-40-80M-6T-30P		30	100	40	32	22	110	80	16.4	9		
BAP400R-100-40-120M-6T-36P		36	100	40	32	22	150	120	16.4	9		

AP 一体式玉米刀盘系列
AP INTEGRATED CORN KNIFE PLATE SERIES

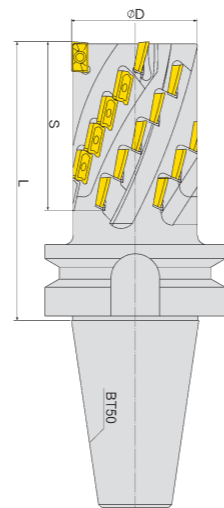

型号 Model		适用条件				螺丝 Screw	扳手 Wrench
		刃数	ϕD	H	S		
YMC050-AP16-97-BT50-4/28T	APMT 1604	4	50	166	97	LD57294010	T-15
YMC063-AP16-97-BT50-4/28T		4	63	166	97		
YMC080-AP16-125-BT50-5/45T		5	80	194	125		
YMC0100-AP16-125-BT50-6/54T		6	100	194	125		

SN 心轴式三面刃系列
SN AXIS TYPE THREE SIDE BLADE SERIES

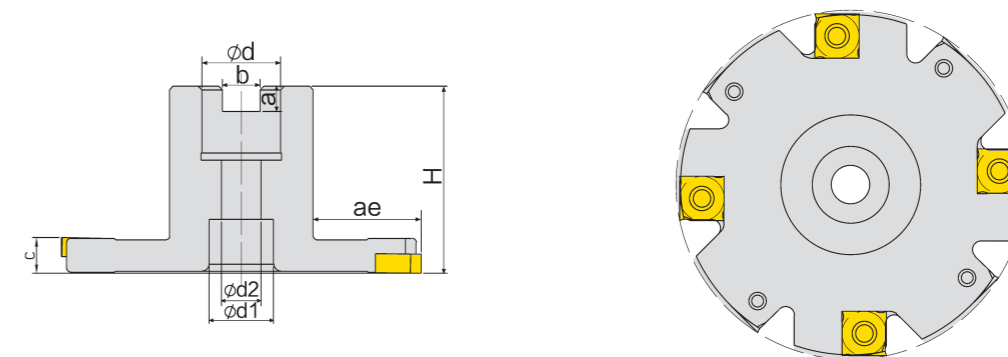
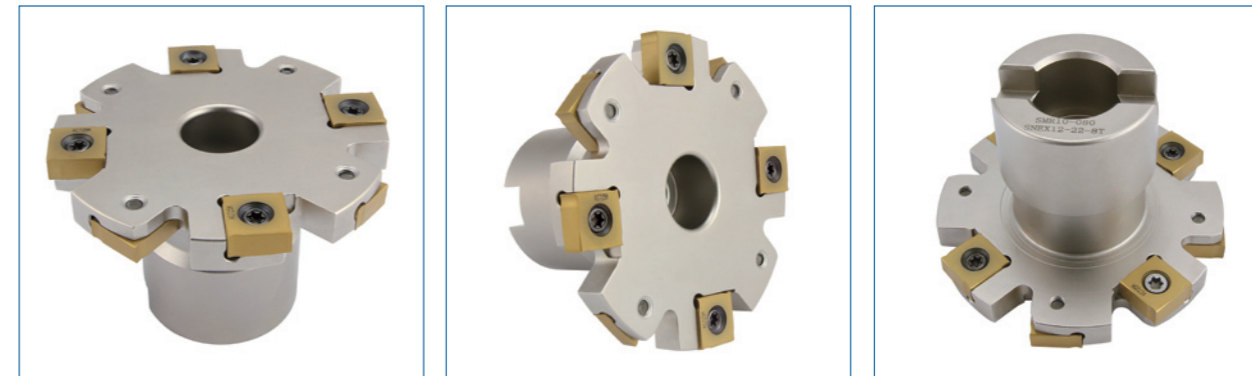

型号 Model		适用条件										固定螺钉 LD	扳手 Wrench
		刃数	ϕD	ϕd	$\phi d1$	$\phi d2$	ae	C	H	b	a		
MSA104063R6A22SN12	SNEX1202	6	63	22	17	11	11	4	40	10.4	7	LD654035-05	T-15
MSA105063R6A22SN12	SNEX1203	6	63	22	17	11	11	5	40	10.4	7	LD654045-05	
MSA106063R6A22SN12	SNEX12T3	6	63	22	17	11	11	6	40	10.4	7	LD654055-05	
MSA107063R6A22SN12	SNEX1204	6	63	22	17	11	11	7	40	10.4	7	LD654065-05	
MSA108063R6A22SN12	SNEX12T4	6	63	22	17	11	11	8	40	10.4	7	LD654075-05	
MSA104080R8A27SN12	SNEX1202	8	80	27	25	13	15.5	4	50	12.4	7	LD654035-05	
MSA105080R8A27SN12	SNEX1203	8	80	27	25	13	15.5	5	50	12.4	7	LD654045-05	
MSA106080R8A27SN12	SNEX12T3	8	80	27	25	13	15.5	6	50	12.4	7	LD654055-05	
MSA107080R8A27SN12	SNEX1204	8	80	27	25	13	15.5	7	50	12.4	7	LD654065-05	
MSA108080R8A27SN12	SNEX12T4	8	80	27	25	13	15.5	8	50	12.4	7	LD654075-05	
MSA104100R10A27SN12	SNEX1202	10	100	27	25	13	25.5	4	50	12.4	7	LD654035-05	
MSA105100R10A27SN12	SNEX1203	10	100	27	25	13	25.5	5	50	12.4	7	LD654045-05	
MSA106100R10A27SN12	SNEX12T3	10	100	27	25	13	25.5	6	50	12.4	7	LD654055-05	
MSA107100R10A27SN12	SNEX1204	10	100	27	25	13	25.5	7	50	12.4	7	LD654065-05	
MSA108100R10A27SN12	SNEX12T4	10	100	27	25	13	25.5	8	50	12.4	7	LD654075-05	
MSA104125R12A32SN12	SNEX1202	12	125	32	40	17	30	4	55	14.4	9	LD654035-05	
MSA105125R12A32SN12	SNEX1203	12	125	32	40	17	30	5	55	14.4	9	LD654045-05	
MSA106125R12A32SN12	SNEX12T3	12	125	32	40	17	30	6	55	14.4	9	LD654055-05	
MSA107125R12A32SN12	SNEX1204	12	125	32	40	17	30	7	55	14.4	9	LD654065-05	
MSA108125R12A32SN12	SNEX12T4	12	125	32	40	17	30	8	55	14.4	9	LD654075-05	
MSA104160R14A40SN12	SNEX1202	14	160	40	47	21	44.5	4	55	16.4	9	LD654035-05	
MSA105160R14A40SN12	SNEX1203	14	160	40	47	21	44.5	5	55	16.4	9	LD654045-05	
MSA106160R14A40SN12	SNEX12T3	14	160	40	47	21	44.5	6	55	16.4	9	LD654055-05	
MSA107160R14A40SN12	SNEX1204	14	160	40	47	21	44.5	7	55	16.4	9	LD654065-05	
MSA108160R14A40SN12	SNEX12T4	14	160	40	47	21	44.5	8	55	16.4	9	LD654075-05	

A

铣刀系列
Milling cutter series

A76

A

铣刀系列
Milling cutter series

A75

SN 盘式三面刃系列
SN DISC THREE SIDE BLADE SERIES

CN 心轴式三面刃系列
CN AXIS TYPE THREE SIDE BLADE SERIES

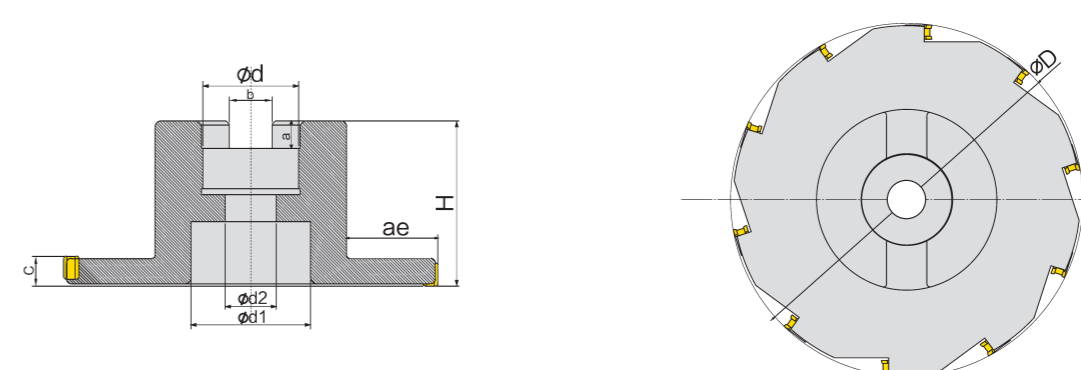
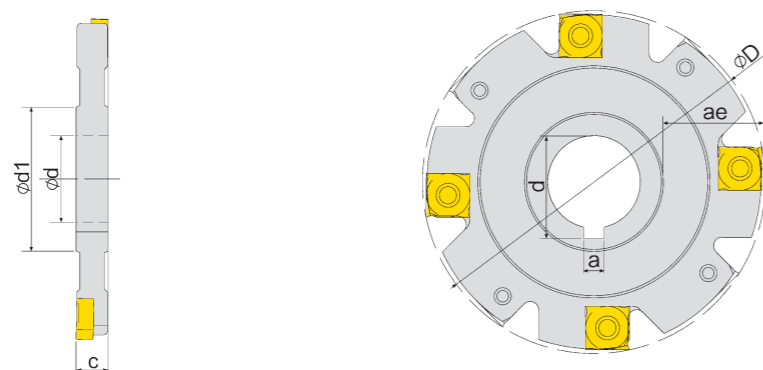
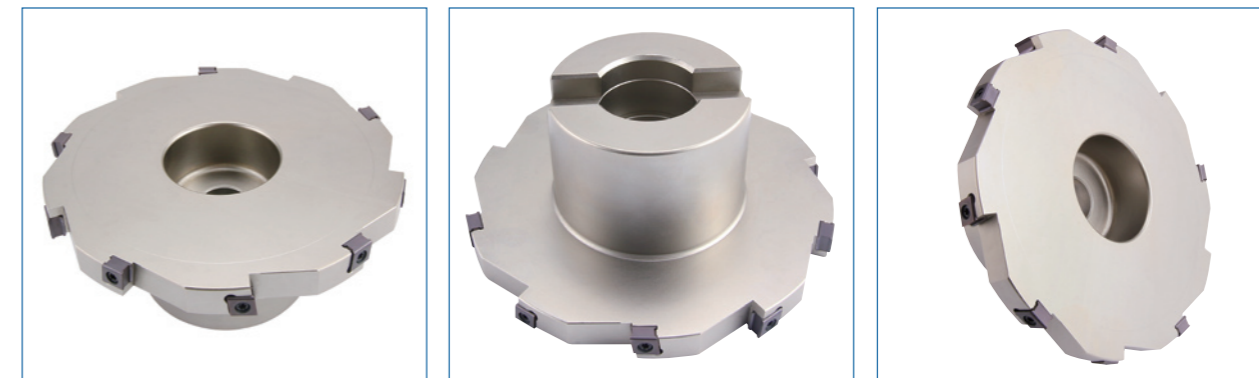

型号 Model	Image	适用条件								固定螺钉 LD	扳手 Wrench
		刃数	ϕD	ϕd	ϕd_1	ae	C	b	a		
MSA104063R6K22SN12	SNEX1202	6	63	22	34	14.5	4	25	6	LD654035-05	T-15
MSA105063R6K22SN12	SNEX1203	6	63	22	34	14.5	5	25	6	LD654045-05	
MSA106063R6K22SN12	SNEX12T3	6	63	22	34	14.5	6	25	6	LD654055-05	
MSA107063R6K22SN12	SNEX1204	6	63	22	34	14.5	7	25	6	LD654065-05	
MSA108063R6K22SN12	SNEX12T4	6	63	22	34	14.5	8	25	6	LD654075-05	
MSA104080R8K22SN12	SNEX1202	8	80	22	34	23	4	25	6	LD654035-05	
MSA105080R8K22SN12	SNEX1203	8	80	22	34	23	5	25	6	LD654045-05	
MSA106080R8K22SN12	SNEX12T3	8	80	22	34	23	6	25	6	LD654055-05	
MSA107080R8K22SN12	SNEX1204	8	80	22	34	23	7	25	6	LD654065-05	
MSA108080R8K22SN12	SNEX12T4	8	80	22	34	23	8	25	6	LD654075-05	
MSA104100R10K27SN12	SNEX1202	10	100	27	45	27.5	4	30	6	LD654035-05	
MSA105100R10K27SN12	SNEX1203	10	100	27	45	27.5	5	30	6	LD654045-05	
MSA106100R10K27SN12	SNEX12T3	10	100	27	45	27.5	6	30	6	LD654055-05	
MSA107100R10K27SN12	SNEX1204	10	100	27	45	27.5	7	30	6	LD654065-05	
MSA108100R10K27SN12	SNEX12T4	10	100	27	45	27.5	8	30	6	LD654075-05	
MSA104125R12K32SN12	SNEX1202	12	125	32	49	38	4	36	8	LD654035-05	
MSA105125R12K32SN12	SNEX1203	12	125	32	49	38	5	36	8	LD654045-05	
MSA106125R12K32SN12	SNEX12T3	12	125	32	49	38	6	36	8	LD654055-05	
MSA107125R12K32SN12	SNEX1204	12	125	32	49	38	7	36	8	LD654065-05	
MSA108125R12K32SN12	SNEX12T4	12	125	32	49	38	8	36	8	LD654075-05	
MSA104160R14K40SN12	SNEX1202	14	160	40	56.5	51.5	4	45	10	LD654035-05	
MSA105160R14K40SN12	SNEX1203	14	160	40	56.5	51.5	5	45	10	LD654045-05	
MSA106160R14K40SN12	SNEX12T3	14	160	40	56.5	51.5	6	45	10	LD654055-05	
MSA107160R14K40SN12	SNEX1204	14	160	40	56.5	51.5	7	45	10	LD654065-05	
MSA108160R14K40SN12	SNEX12T4	14	160	40	56.5	51.5	8	45	10	LD654075-05	
MSA104200R18K40SN12	SNEX1202	18	200	40	56.5	71.5	4	45	10	LD654035-05	
MSA105200R18K40SN12	SNEX1203	18	200	40	56.5	71.5	5	45	10	LD654045-05	
MSA106200R18K40SN12	SNEX12T3	18	200	40	56.5	71.5	6	45	10	LD654055-05	
MSA107200R18K40SN12	SNEX1204	18	200	40	56.5	71.5	7	45	10	LD654065-05	
MSA108200R18K40SN12	SNEX12T4	18	200	40	56.5	71.5	8	45	10	LD654075-05	

型号 Model	Image	适用条件									螺丝 Screw	扳手 Wrench	
		刃数	ϕD	ϕd	ϕd_1	ϕd_2	ae	C	H	b			a
MSA110063R6B22CN07	CNEU070508-PM CNEU070508-KM 金鹭	6	63	22	17	11	11	10	40	10.4	7	LD40283070 T8-40	T-8
MSA112063R6B22CN07		6	63	22	17	11	11	12	40	10.4	7		
MSA110080R8B27CN07		8	80	27	25	13	15.5	10	50	12.4	7		
MSA112080R8B27CN07		8	80	27	25	13	15.5	12	50	12.4	7		
MSA110100R8B27CN07		8	100	27	25	13	25.5	10	50	12.4	7		
MSA112100R8B27CN07		8	100	27	25	13	25.5	12	50	12.4	7		
MSA110125R10B32CN07		10	125	32	40	17	30	10	55	14.4	9		
MSA112125R10B32CN07		10	125	32	40	17	30	12	55	14.4	9		
MSA110160R12B40CN07		12	160	40	47	21	44.5	10	55	16.4	9		
MSA112160R12B40CN07		12	160	40	47	21	44.5	12	55	16.4	9		

A 铣刀系列 Milling cutter series

A 铣刀系列 Milling cutter series

CN-S 心轴式三面刃系列
CN-S AXIS TYPE THREE SIDE BLADE SERIES

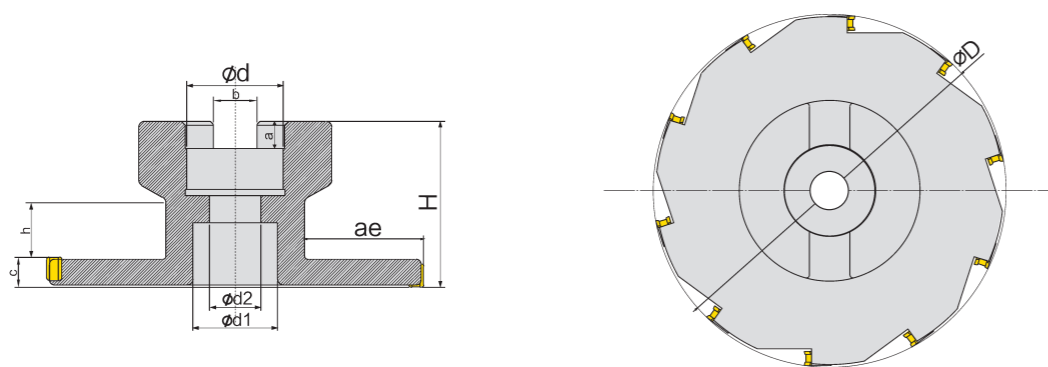
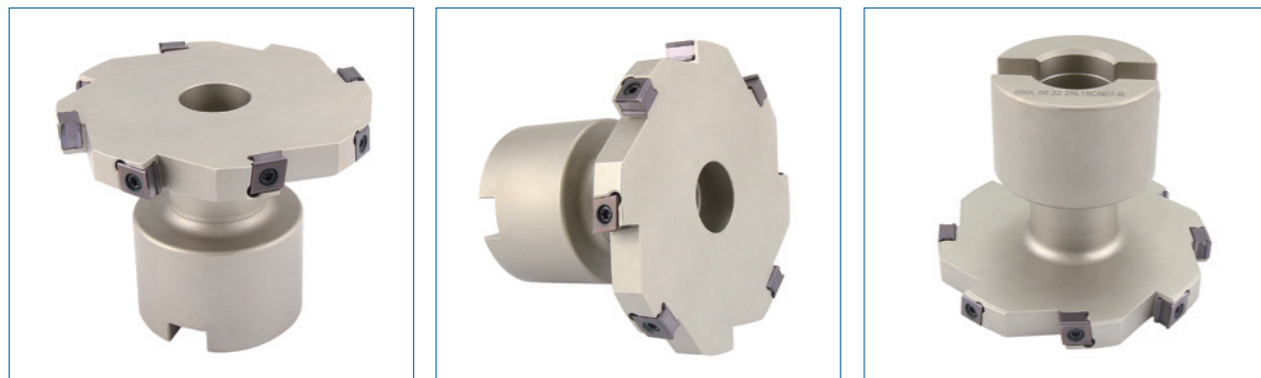

型号 Model		适用条件										螺丝 Screw	扳手 Wrench
		刃数	ϕD	ϕd	$\phi d1$	$\phi d2$	ae	C	H	b	a		
MSA110063R6B22CN07-S	CNEU070508-PM CNEU070508-KM 金鹭	6	63	22	17	11	16	10	40	10.4	7	LD40283070	T-8
MSA112063R6B22CN07-S		6	63	22	17	11	16	12	40	10.4	7		
MSA110080R8B27CN07-S		8	80	27	20	13	20.5	10	50	12.4	7		
MSA112080R8B27CN07-S		8	80	27	20	13	20.5	12	50	12.4	7		
MSA110100R8B27CN07-S		8	100	27	20	13	30.6	10	50	12.4	7		
MSA112100R8B27CN07-S		8	100	27	20	13	30.5	12	50	12.4	7		

CN 盘式三面刃系列
CN DISC THREE SIDE BLADE SERIES

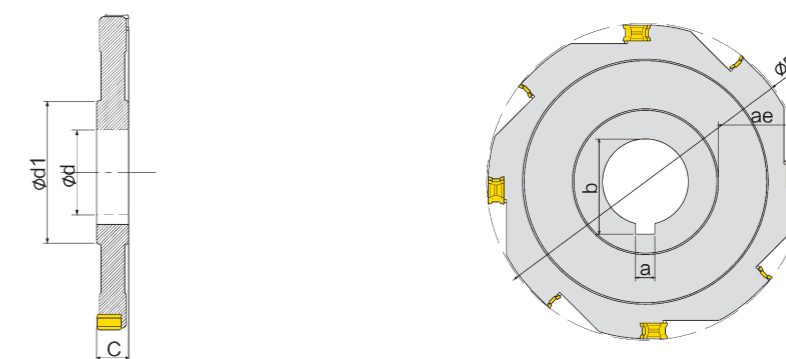

型号 Model		适用条件								螺丝 Screw	扳手 Wrench
		刃数	ϕD	ϕd	$\phi d1$	ae	C	b	a		
MSA110050R6K16CN07	CNEU070508-PM CNEU070508-KM 金鹭	6	50	16	26	12	10	18	4	LD40283070	T-8
MSA111050R6K16CN07		6	50	16	26	12	11	18	4		
MSA112050R6K16CN07		6	50	16	26	12	12	18	4		
MSA113050R6K16CN07		6	50	16	26	12	13	18	4		
MSA110063R6K22CN07		6	63	22	34	14.5	10	25	6		
MSA111063R6K22CN07		6	63	22	34	14.5	11	25	6		
MSA112063R6K22CN07		6	63	22	34	14.5	12	25	6		
MSA113063R6K22CN07		6	63	22	34	14.5	13	25	6		
MSA110080R8K22CN07		8	80	22	34	23	10	25	6		
MSA111080R8K22CN07		8	80	22	34	23	11	25	6		
MSA112080R8K22CN07		8	80	22	34	23	12	25	6		
MSA113080R8K22CN07		8	80	22	34	23	13	25	6		
MSA110100R8K27CN07		8	100	27	45	27.5	10	30	6		
MSA111100R8K27CN07		8	100	27	45	27.5	11	30	6		
MSA112100R8K27CN07		8	100	27	45	27.5	12	30	6		
MSA113100R8K27CN07		8	100	27	45	27.5	13	30	6		
MSA110125R10K32CN07		10	125	32	49	38	10	36	8		
MSA111125R10K32CN07		10	125	32	49	38	11	36	8		
MSA112125R10K32CN07		10	125	32	49	38	12	36	8		
MSA113125R10K32CN07		10	125	32	49	38	13	36	8		
MSA110160R12K40CN07		12	160	40	56.5	51.5	10	45	10		
MSA111160R12K40CN07		12	160	40	56.5	51.5	11	45	10		
MSA112160R12K40CN07		12	160	40	56.5	51.5	12	45	10		
MSA113160R12K40CN07		12	160	40	56.5	51.5	13	45	10		
MSA110200R16K40CN07		16	200	40	56.5	71.5	10	45	10		
MSA111200R16K40CN07		16	200	40	56.5	71.5	11	45	10		
MSA112200R16K40CN07		16	200	40	56.5	71.5	12	45	10		
MSA113200R16K40CN07		16	200	40	56.5	71.5	13	45	10		

A

铣刀系列
Milling cutter series

A

铣刀系列
Milling cutter series

GM刀杆 **新品**



图1

GM刀盘 **新品**

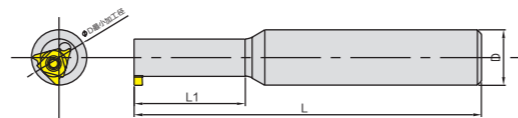

图2

型号 Model		φD	φd	D	L	L1	图示	螺丝 Screw	扳手 Wrench
GM-20*3-C20-1T	QC16 株钻扣槽刀片	20	13.4	20	125	40	图1		
GM-25*3-C20-1T		25	18.8	20	125	40			
GM-28*3-C25-2T		28	-	25	125	40			
GM-32*3-C25-2T		32	-	25	125	-			
GM-55*3-C48-6T-22		55	-	48	40	-	图2		

CC T形刀系列
CC T-SHAPED KNIFE SERIES

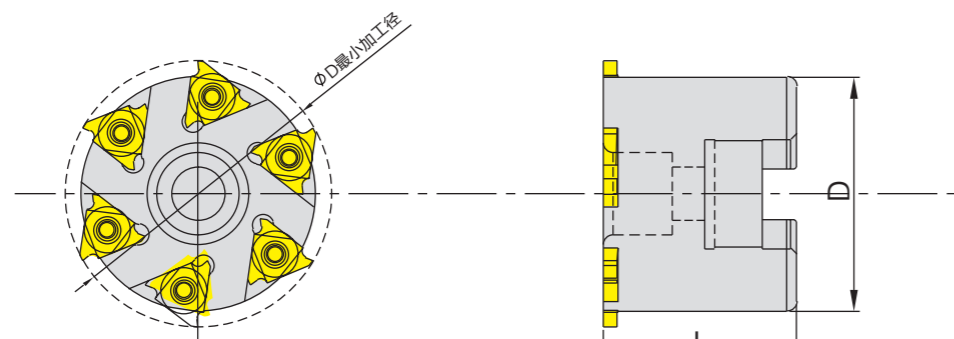
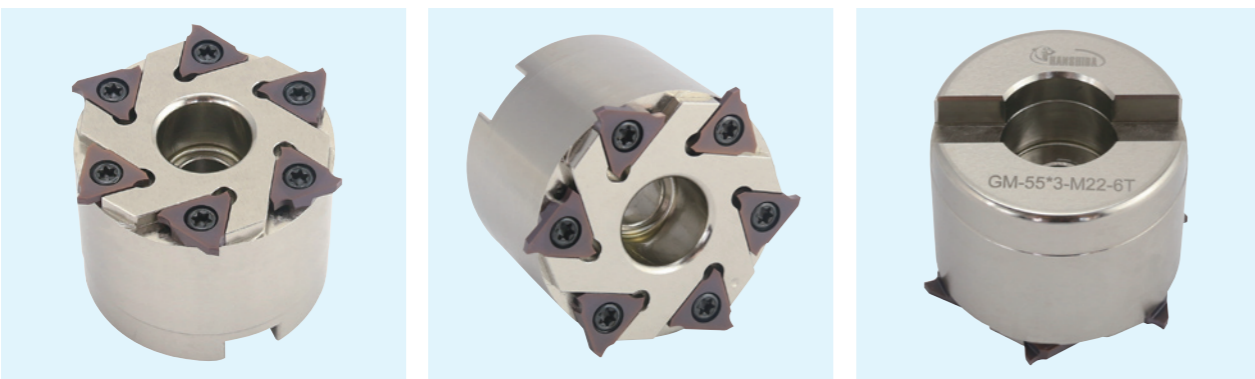
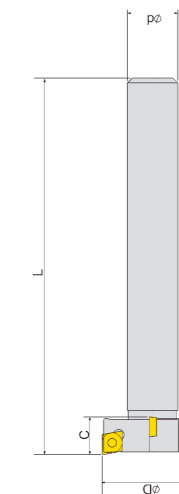

型号 Model		适用条件					螺丝 Screw	扳手 Wrench
		刃数	D	C	L	d		
TMC-20-H08-C14-T2-80 CC06	CCMT 060204	2	20	8	80	14	LD35212550 T8-30	T-8
TMC-20-H08-C14-T2-120 CC06		2	20	8	120	14		
TMC-20-H08-C14-T2-150 CC06		2	20	8	150	14		
TMC-20-H10-C14-T2-80 CC06		2	20	10	80	14		
TMC-20-H10-C14-T2-120 CC06		2	20	10	120	14		
TMC-20-H10-C14-T2-150 CC06		2	20	10	150	14		
TMC-25-H08-C16-T4-80 CC06		4	25	8	80	16		
TMC-25-H08-C16-T4-120 CC06		4	25	8	120	16		
TMC-25-H08-C16-T4-150 CC06		4	25	8	150	16		
TMC-25-H10-C16-T4-80 CC06		4	25	10	80	16		
TMC-25-H10-C16-T4-120 CC06		4	25	10	120	16		
TMC-25-H10-C16-T4-150 CC06		4	25	10	150	16		
TMC-30-H08-C16-T4-80 CC06		4	30	8	80	16		
TMC-30-H08-C16-T4-120 CC06		4	30	8	120	16		
TMC-30-H08-C16-T4-150 CC06		4	30	8	150	16		
TMC-30-H10-C16-T4-80 CC06		4	30	10	80	16		
TMC-30-H10-C16-T4-120 CC06		4	30	10	120	16		
TMC-30-H10-C16-T4-150 CC06		4	30	10	150	16		
TMC-35-H08-C20-T4-80 CC06		4	35	8	80	20		
TMC-35-H08-C20-T4-120 CC06		4	35	8	120	20		
TMC-35-H08-C20-T4-150 CC06		4	35	8	150	20		
TMC-35-H10-C20-T4-80 CC06		4	35	10	80	20		
TMC-35-H10-C20-T4-120 CC06		4	35	10	120	20		
TMC-35-H10-C20-T4-150 CC06		4	35	10	150	20		
TMC-40-H08-C20-T6-80 CC06		6	40	8	80	20		
TMC-40-H08-C20-T6-120 CC06		6	40	8	120	20		
TMC-40-H08-C20-T6-150 CC06		6	40	8	150	20		
TMC-40-H10-C20-T6-80 CC06		6	40	10	80	20		
TMC-40-H10-C20-T6-120 CC06		6	40	10	120	20		
TMC-40-H10-C20-T6-150 CC06		6	40	10	150	20		
TMC-50-H08-C25-T6-80 CC06		6	50	8	80	25		
TMC-50-H08-C25-T6-120 CC06		6	50	8	120	25		
TMC-50-H08-C25-T6-150 CC06		6	50	8	150	25		
TMC-50-H10-C25-T6-80 CC06		6	50	10	80	25		
TMC-50-H10-C25-T6-120 CC06		6	50	10	120	25		
TMC-50-H10-C25-T6-150 CC06		6	50	10	150	25		
TMC-63-H10-C32-T8-80 CC06		8	63	10	80	32		
TMC-63-H10-C32-T8-120 CC06		8	63	10	120	32		
TMC-63-H10-C32-T8-150 CC06		8	63	10	150	32		
TMC-80-H10-C32-T8-80 CC06		8	80	10	80	32		
TMC-80-H10-C32-T8-120 CC06	8	80	10	120	32			
TMC-80-H10-C32-T8-150 CC06	8	80	10	150	32			

A

铣刀系列
Milling cutter series

A

铣刀系列
Milling cutter series

SD T形刀系列
SD T-SHAPED KNIFE SERIES

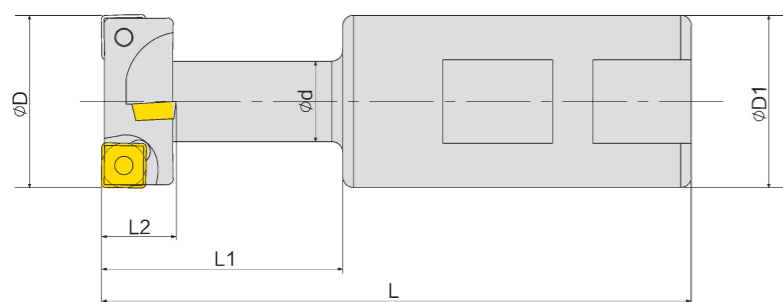
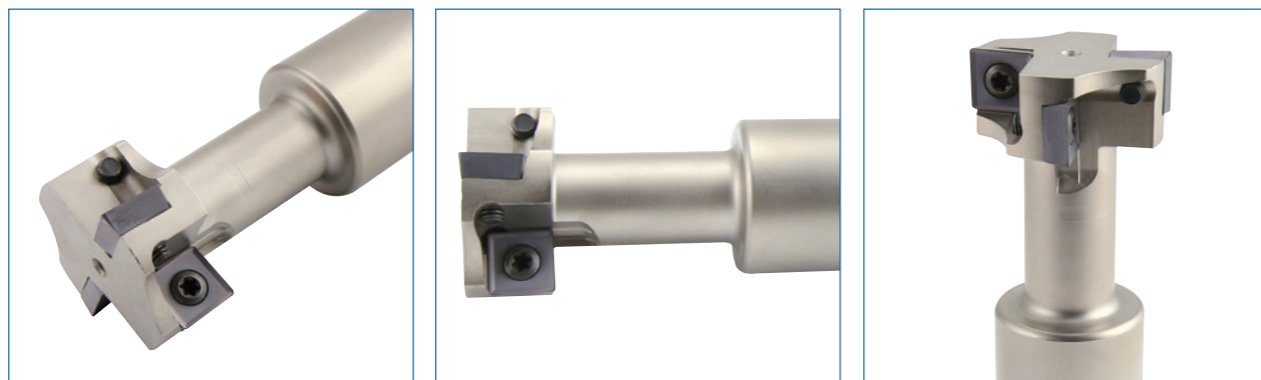

型号 Model	刃数 Blade number	适用条件	适用条件						螺丝 Screw	扳手 Wrench	T型槽 规格 Blade number
			D	D1	L	L1	L2	d			
TMS-025C21-MP06-T09-02	2	钻石 MPHT060304-DM	21	25	100	32	9	10	LD35212550	T-8	12
TMS-025C25-MP06-T11-02	2		25	25	100	35	11	12	T8-30		14
TMS-032C32-MP08-T14-04	4	钻石 MPHT060304-DM	32	32	110	45	14	15	LD40283070T8-40	T-8	18
TMS-040C32-MP12-T18-04	4		40	32	125	55	18	19			22
TMS-050C32-MP12-T22-04	4	钻石 MPHT120408-DM	50	32	135	65	22	25	LD70275012	T-20	28
TMS-060C32-MP12-T28-06	6		60	32	150	80	28	32	T20-70		36

SMC 盘式三面刃系列
SMC DISC THREE SIDE BLADE SERIES

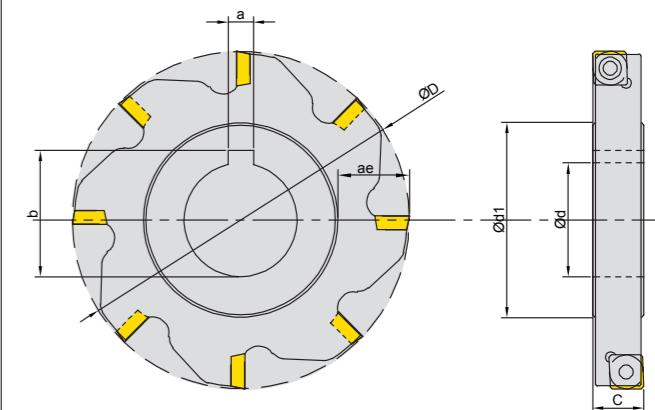

型号 Model	适用条件	适用条件								固定螺钉 LD	扳手 Wrench
		刃数	φD	φd	φd1	ae	C	b	a		
SMC-63-8-22-8T	MPHT06	8	63	22	35.2	13	8	25	6	LD35212550T8-30	T-8
SMC-63-10-22-8T	MPHT06	8	63	22	35.2	13	10	25	6	LD40283070T8-40	T-8
SMC-63-12-22-8T	MPHT08	8	63	22	35.2	13	12	25	6	LD70275012T20-70	T-20
SMC-63-16-22-6T	MPHT12	6	63	22	35.8	13	16	25	6	LD35212550T8-30	T-8
SMC-80-8-27-10T	MPHT06	10	80	27	46.2	16	8	30	6	LD40283070T8-40	T-8
SMC-80-10-27-10T	MPHT06	10	80	27	46.2	16	10	30	6	LD40283070T8-40	T-8
SMC-80-12-27-10T	MPHT08	10	80	27	46.2	16	12	30	6	LD70275012T20-70	T-20
SMC-80-16-27-6T	MPHT12	6	80	27	46.8	16	16	30	6	LD35212550T8-30	T-8
SMC-100-8-27-12T	MPHT06	12	100	27	46.2	26	8	30	6	LD40283070T8-40	T-8
SMC-100-10-27-12T	MPHT06	12	100	27	46.2	26	10	30	6	LD70275012T20-70	T-20
SMC-100-12-27-10T	MPHT08	10	100	27	46.2	26	12	30	6	LD35212550T8-30	T-8
SMC-100-16-27-8T	MPHT12	8	100	27	46.8	26	16	30	6	LD40283070T8-40	T-8
SMC-100-8-32-12T	MPHT06	12	100	32	50.2	24	8	36	8	LD40283070T8-40	T-8
SMC-100-10-32-12T	MPHT06	12	100	32	50.2	24	10	36	8	LD70275012T20-70	T-20
SMC-100-12-32-10T	MPHT08	10	100	32	50.2	24	12	36	8	LD35212550T8-30	T-8
SMC-100-16-32-8T	MPHT12	8	100	32	50.8	24	16	36	8	LD40283070T8-40	T-8
SMC-100-20-32-8T	MPHT12	8	100	32	50.8	24	20	36	8	LD70275012T20-70	T-20
SMC-125-8-40-14T	MPHT06	14	125	40	59.2	32	8	45	10	LD35212550T8-30	T-8
SMC-125-10-40-14T	MPHT06	14	125	40	59.2	32	10	45	10	LD40283070T8-40	T-8
SMC-125-12-40-12T	MPHT08	12	125	40	59.2	32	12	45	10	LD70275012T20-70	T-20
SMC-125-16-40-8T	MPHT12	8	125	40	59.8	32	16	45	10	LD35212550T8-30	T-8
SMC-125-20-40-8T	MPHT12	8	125	40	59.8	32	20	45	10	LD40283070T8-40	T-8
SMC-160-10-40-16T	MPHT06	16	160	40	59.2	49	10	45	10	LD70275012T20-70	T-20
SMC-160-12-40-12T	MPHT08	12	160	40	59.2	49	12	45	10	LD35212550T8-30	T-8
SMC-160-16-40-10T	MPHT12	10	160	40	59.8	49	16	45	10	LD40283070T8-40	T-8
SMC-160-20-40-10T	MPHT12	10	160	40	59.8	49	20	45	10	LD70275012T20-70	T-20
SMC-200-10-50-16T	MPHT06	16	200	50	71.2	63	10	55.2	14	LD35212550T8-30	T-8
SMC-200-12-50-16T	MPHT08	16	200	50	71.2	63	12	55.2	14	LD40283070T8-40	T-8
SMC-200-16-50-16T	MPHT12	16	200	50	71.8	63	16	55.2	14	LD70275012T20-70	T-20
SMC-200-20-50-16T	MPHT12	16	200	50	71.8	63	20	55.2	14	LD35212550T8-30	T-8
SMC-250-10-50-16T	MPHT06	16	250	50	71.2	88	10	55.2	14	LD40283070T8-40	T-8
SMC-250-12-50-16T	MPHT08	16	250	50	71.2	88	12	55.2	14	LD70275012T20-70	T-20
SMC-250-16-50-16T	MPHT12	16	250	50	71.8	88	16	55.2	14	LD35212550T8-30	T-8
SMC-250-20-50-16T	MPHT12	16	250	50	71.8	88	20	55.2	14	LD40283070T8-40	T-8

A

铣刀系列
Milling cutter series

A

铣刀系列
Milling cutter series

RT形刀系列 RT KNIFE SERIES

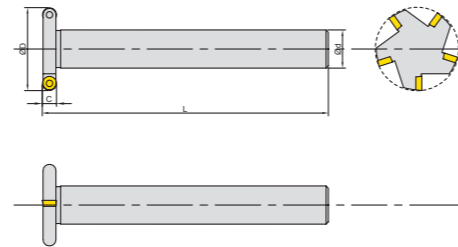
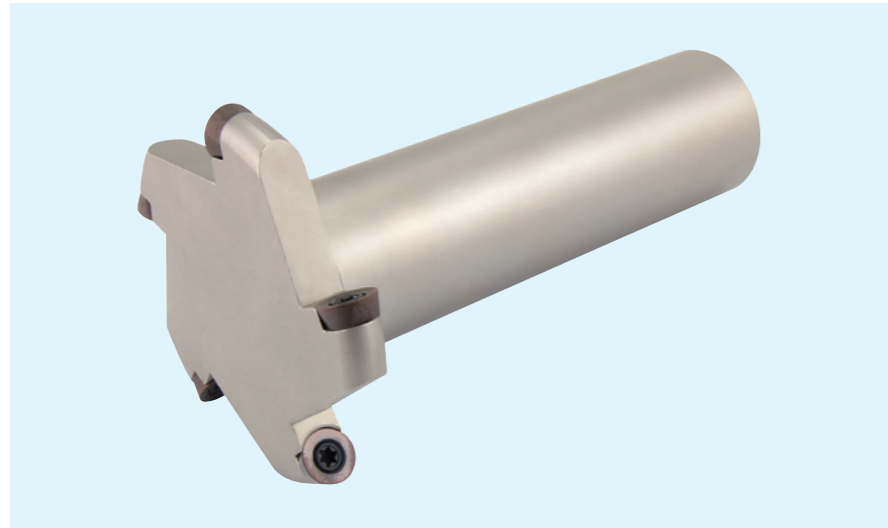

型号 Model	刃数 Blade number		适用条件				螺丝 Screw	扳手 Wrench
			D	C	L	d		
TMR-20-R3-C14-T2-120	2	RCMT0602	20	6	120	14	LD35272560T8-30	T-8
TMR-20-R4-C14-T2-120	2	RPMT08T2	20	8	120	14	LD40303064T8-40	T-8
TMR-25-R3-C14-T4-120	4	RCMT0602	25	6	120	14	LD35272560T8-30	T-8
TMR-25-R4-C14-T3-120	3	RPMT08T2	25	8	120	14	LD40303064T8-40	T-8
TMR-25-R5-C14-T2-120	2	RPMT10T3	25	10	120	14	LD53273580T15-45	T-15
TMR-30-R3-C16-T5-120	5	RCMT0602	30	6	120	16	LD35272560T8-30	T-8
TMR-30-R4-C16-T4-120	4	RPMT08T2	30	8	120	16	LD40303064T8-40	T-8
TMR-30-R5-C16-T3-120	3	RPMT10T3	30	10	120	16	LD53273580T15-45	T-15
TMR-30-R6-C16-T2-120	2	RPMT1204	30	12	120	16	LD57294010T15-60	T-15
TMR-35-R3-C16-T5-120	5	RCMT0602	35	6	120	16	LD35272560T8-30	T-8
TMR-35-R4-C16-T5-120	5	RPMT08T2	35	8	120	16	LD40303064T8-40	T-8
TMR-35-R5-C16-T3-120	3	RPMT10T3	35	10	120	16	LD53273580T15-45	T-15
TMR-35-R6-C16-T2-120	2	RPMT1204	35	12	120	16	LD57294010T15-60	T-15
TMR-40-R3-C20-T6-120	6	RCMT0602	40	6	120	20	LD35272560T8-30	T-8
TMR-40-R4-C20-T5-120	5	RPMT08T2	40	8	120	20	LD40303064T8-40	T-8
TMR-40-R5-C20-T4-120	4	RPMT10T3	40	10	120	20	LD53273580T15-45	T-15
TMR-40-R6-C20-T3-120	3	RPMT1204	40	12	120	20	LD57294010T15-60	T-15
TMR-45-R3-C20-T6-120	6	RCMT0602	45	6	120	20	LD35272560T8-30	T-8
TMR-45-R4-C20-T5-120	5	RPMT08T2	45	8	120	20	LD40303064T8-40	T-8
TMR-45-R5-C20-T4-120	4	RPMT10T3	45	10	120	20	LD53273580T15-45	T-15
TMR-45-R6-C20-T4-120	4	RPMT1204	45	12	120	20	LD57294010T15-60	T-15
TMR-50-R3-C25-T6-120	6	RCMT0602	50	6	120	25	LD35272560T8-30	T-8
TMR-50-R4-C25-T6-120	6	RPMT08T2	50	8	120	25	LD40303064T8-40	T-8
TMR-50-R5-C25-T4-120	4	RPMT10T3	50	10	120	25	LD53273580T15-45	T-15
TMR-50-R6-C25-T4-120	4	RPMT1204	50	12	120	25	LD57294010T15-60	T-15

TMR 盘式三面刃系列 TMR DISC THREE SIDED BLADE SERIES

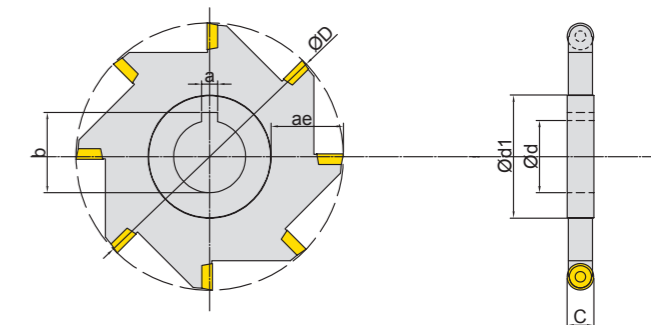

型号 Model		适用条件								螺丝 Screw	扳手 Wrench
		刃数	φD	φd	φd1	ae	C	b	a		
TMR-63-R3-8-M22	RC0602	8	63	22	34.4	14.3	6	25	6	LD35272560T8-30	T8
TMR-63-R4-6-M22	RP08T2	6	63	22	34.4	14.3	8	25	6	LD40303064T8-40	T8
TMR-63-R5-6-M22	RP10T3	6	63	22	34.4	14.3	10	25	6	LD53273578T10-40	T10
TMR-63-R6-5-M22	RP1204	5	63	22	34.4	14.3	12	25	6	LD57274010T15-60	T15
TMR-80-R3-8-M27	RC0602	8	80	27	46	17	6	30	6	LD35272560T8-30	T8
TMR-80-R4-7-M27	RP08T2	7	80	27	46	17	8	30	6	LD40303064T8-40	T8
TMR-80-R5-6-M27	RP10T3	6	80	27	46	17	10	30	6	LD53273578T10-40	T10
TMR-80-R6-6-M27	RP1204	6	80	27	46	17	12	30	6	LD57274010T15-60	T15
TMR-100-R3-10-M27	RC0602	10	100	27	46	27	6	30	6	LD35272560T8-30	T8
TMR-100-R4-8-M27	RP08T2	8	100	27	46	27	8	30	6	LD40303064T8-40	T8
TMR-100-R5-8-M27	RP10T3	8	100	27	46	27	10	30	6	LD53273578T10-40	T10
TMR-100-R6-6-M27	RP1204	6	100	27	46	27	12	30	6	LD57274010T15-60	T15
TMR-125-R4-10-M32	RP08T2	10	125	32	49.3	37.5	8	36	8	LD40303064T8-40	T8
TMR-125-R5-8-M32	RP10T3	8	125	32	49.3	37.5	10	36	8	LD53273578T10-40	T10
TMR-125-R6-8-M32	RP1204	8	125	32	49.3	37.5	12	36	8	LD57274010T15-60	T15
TMR-125-R8-6-M32	RD1604	6	125	32	49.3	37.5	16	36	8	LD70255012T20-80	T20
TMR-160-R4-12-M40	RP08T2	12	160	40	58.3	50.5	8	45	10	LD40303064T8-40	T8
TMR-160-R5-10-M40	RP10T3	10	160	40	58.3	50.5	10	45	10	LD53273578T10-40	T10
TMR-160-R6-8-M40	RP1204	8	160	40	58.3	50.5	12	45	10	LD57274010T15-60	T15
TMR-160-R8-8-M40	RD1604	8	160	40	58.3	50.5	16	45	10	LD70255012T20-80	T20
TMR-200-R5-12-M50	RP10T3	12	200	50	70.3	64.5	10	55.2	14	LD53273578T10-40	T10
TMR-200-R6-10-M50	RP1204	10	200	50	70.3	64.5	12	55.2	14	LD57274010T15-60	T15
TMR-200-R8-8-M50	RD1604	8	200	50	70.3	64.5	16	55.2	14	LD70255012T20-80	T20
TMR-200-R10-8-M50	RD2006	8	200	50	70.3	64.5	20	55.2	14	LD11286016T25-82	T25
TMR-250-R5-12-M50	RP10T3	12	250	50	70.3	89.5	10	55.2	14	LD53273578T10-40	T10
TMR-250-R6-12-M50	RP1204	12	250	50	70.3	89.5	12	55.2	14	LD57274010T15-60	T15
TMR-250-R8-10-M50	RD1604	10	250	50	70.3	89.5	16	55.2	14	LD70255012T20-80	T20
TMR-250-R10-8-M50	RD2006	8	250	50	70.3	89.5	20	55.2	14	LD11286016T25-82	T25

A
铣刀系列
Milling cutter series

A
铣刀系列
Milling cutter series

燕尾刀系列刀盘
SWALLOWTAIL KNIFE SERIES DISC

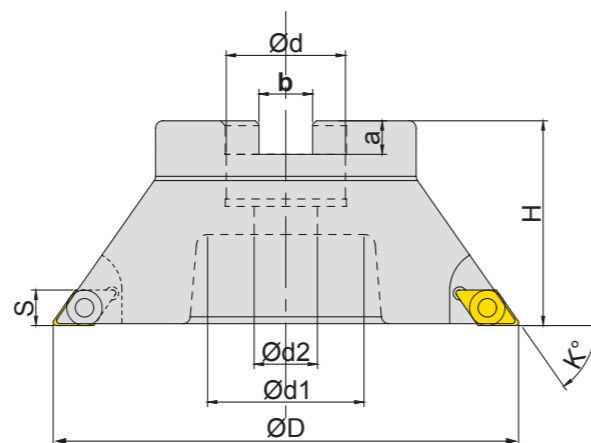
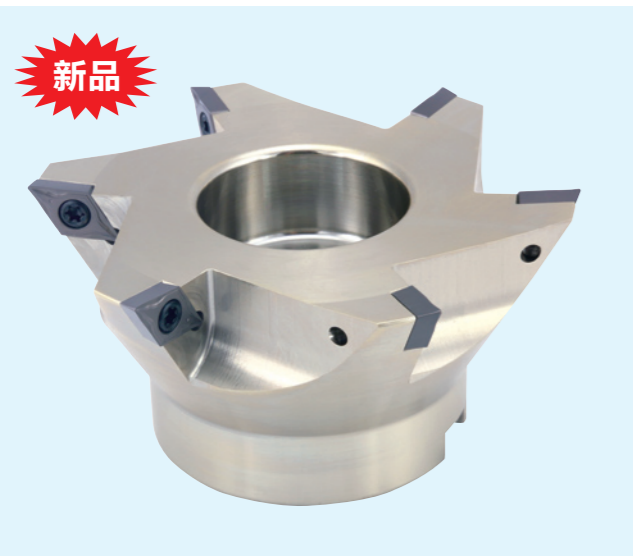

型号 Model	适用条件	适用条件										螺丝 Screw	扳手 Wrench
		刃数	ϕD	ϕd	$\phi d1$	$\phi d2$	H	S	b	K°	a		
YW55-100-M27-6T DC11	DCMT11	6	100	27	34	13	50	8	12.4	55	7	LD57294010 T15-60	T-15
YW55-125-M32-7T DC11		7	125	32	42	17	55	8	14.4	55	9		
YW60-100-M27-6T DC11		6	100	27	34	13	50	8	12.4	60	7		
YW60-125-M30-7T DC11		7	125	32	42	17	55	8	14.4	60	9		

燕尾刀系列刀杆
SWALLOWTAIL KNIFE SERIES BLADE ROD

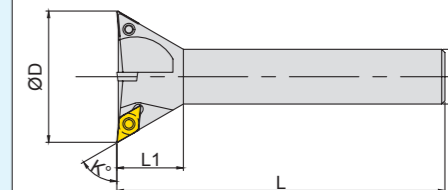
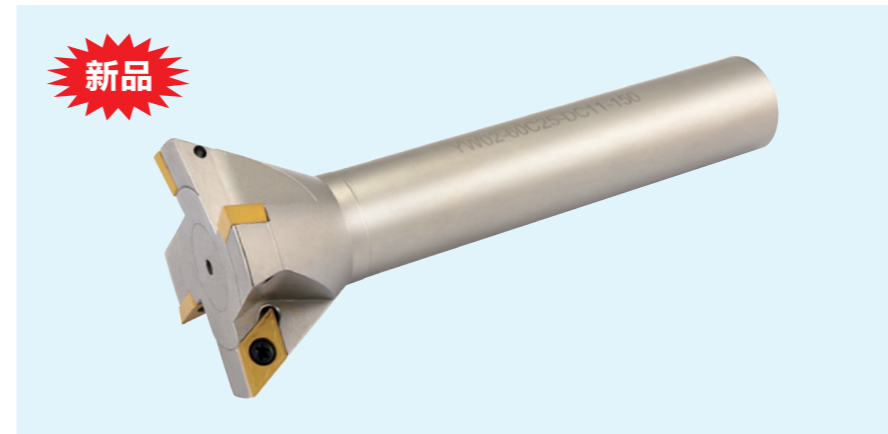

型号 Model		适用条件						螺丝 Screw	扳手 Wrench
		刃数	ϕD	ϕd	L	L1	K		
YW45-30-C20-120-2T VC08	VCMT08	2	30	20	120	25	45	LD36272570 T8-37	T8
YW45-40-C20-160-2T VC11	VCMT11	2	40	20	160	25	45		
YW45-50-C25-160-3T VC11	VCMT16	3	50	25	160	30	45	LD50203599 T15-40	T15
YW45-60-C32-160-3T VC16		3	60	32	160	40	45		
YW45-80-C32-160-4T VC16		4	80	32	160	40	45		
YW55-25-C20-120-2T DC07		DCMT07	2	25	20	120	25		
YW55-30-C20-120-3T DC07	DCMT11	3	30	20	120	25	55		
YW55-40-C25-160-3T DC11		3	40	25	160	30	55		
YW55-50-C32-160-3T DC11		4	50	32	160	40	55		
YW55-60-C32-160-4T DC11		5	60	32	160	40	55		
YW55-80-C32-160-5T DC11	DCMT07	2	80	32	160	40	55	LD36272570 T8-37	T8
YW60-25-C20-120-2T DC07		3	25	20	120	25	60		
YW60-30-C20-120-3T DC07		3	30	20	120	25	60		
YW60-40-C25-160-3T DC11		3	40	25	160	30	60		
YW60-60-C32-160-3T DC11	DCMT11	3	50	32	160	40	60	LD50203599 T15-40	T15
YW60-60-C32-160-4T DC11		4	60	32	160	40	60		
YW60-80-C32-160-4T DC11		4	80	32	160	45	60		

CC 反拉刀系列
CC ANTI - BROACH SERIES

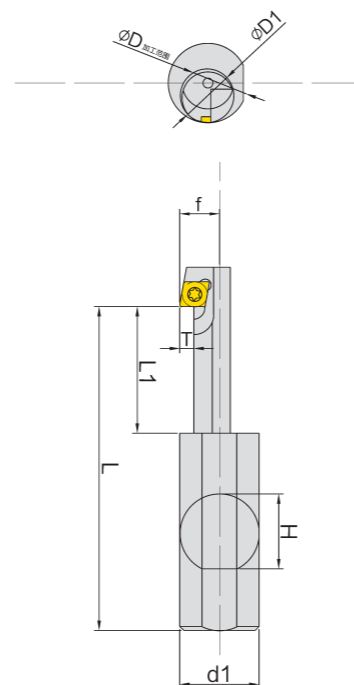

型号 Model		适用条件						φD 加工范围	φD1	T	L	L1	d1	H	螺丝 Screw	扳手 Wrench
		φD 加工范围	φD1	T	L	L1	d1									
FLD 0915D20-28	CC□□0602	15	9	3.3	78	28	20	19	LD352506	T8						
FLD 1118D20-35		18	11	3.8	85	35										
FLD 1320D20-42		20	13	3.8	92	42										
FLD 1524D20-52		24	15	4.8	99	49										
FLD 1727D20-32	CC□□09T3	27	17	5.3	106	56	25	24	LD353509	T15						
FLD 2133D20-32		33	21	6.3	120	70										
FLD 2336D20-32		36	23	6.8	127	77										
FLD 2539D20-52		39	25	7.3	134	84										

可根据客户要求来函订做

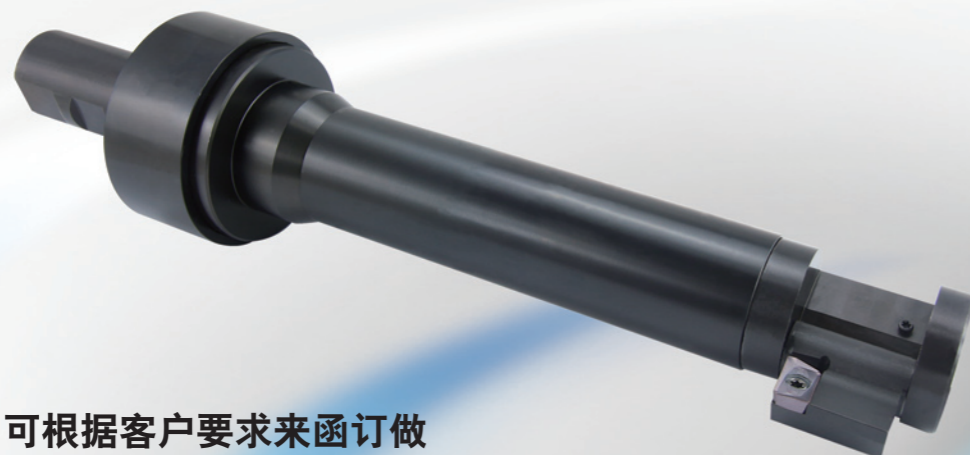

● 可根据客户要求来函订做

TC 倒角刀系列
TC ROSE REAMER SERIES

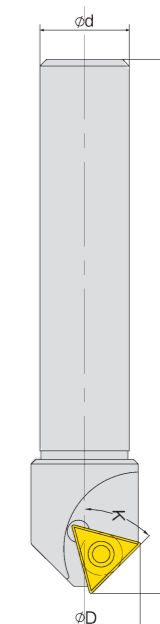
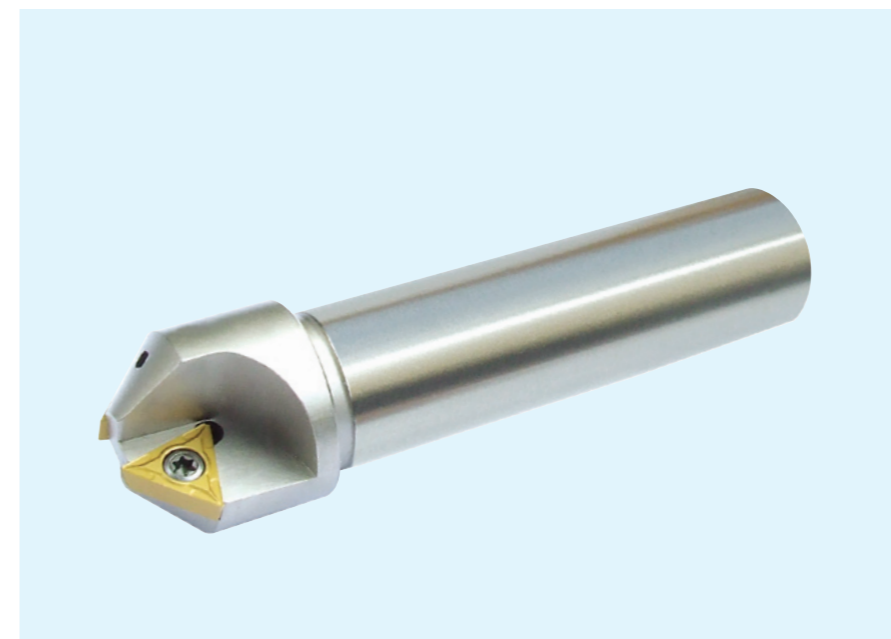

型号 Model	刃数 Blade number		D	D1	d	L	K°	螺丝 Screw	扳手 Wrench			
B15TC11 20 1T20-120	1	TC□□1102□□	20	15	20	120	15	LD352506	T-8			
B15TC11 25 2T20-120	2		25	20	20	120	15					
B30TC11 20 1T20-120	1		20	10.3	20	120	30					
B30TC11 25 2T20-120	2		25	15.3	20	120	30					
B45TC11 20 1T20-120	1		20	6.2	20	120	45					
B45TC11 25 2T20-120	2		25	11.2	20	120	45					
B60TC11 20 1T20-120	1		20	2.9	20	120	60					
B60TC11 25 2T20-120	2		25	7.9	20	120	60					
B15TC16 20 1T20-120	1		TC□□16T3□□	20	12.2	20	120			15	LD574010	T-15
B15TC16 32 2T25-120	2			32	24.2	25	120			15		
B30TC16 20 1T20-120	1	20		4.8	20	120	30					
B30TC16 32 2T25-120	2	32		16.8	25	120	30					
B30TC16 40 2T25-120	2	40		24.8	25	120	30					
B45TC16 20 1T20-120	1	20		3.4	20	120	45					
B45TC16 32 2T25-120	2	32		15.4	25	120	45					
B45TC16 40 2T25-120	2	40		23.4	25	120	45					
B60TC16 20 1T20-120	1	20		1.4	20	120	60					
B60TC16 32 2T25-120	2	32		13.4	25	120	60					
B60TC16 40 2T25-120	2	40	21.4	25	120	60						

AP1604 倒角刀系列 (可用废刀片)
AP 1604 A SERIES OF CHAMFERING KNIVES (WITH A WASTE BLADE)

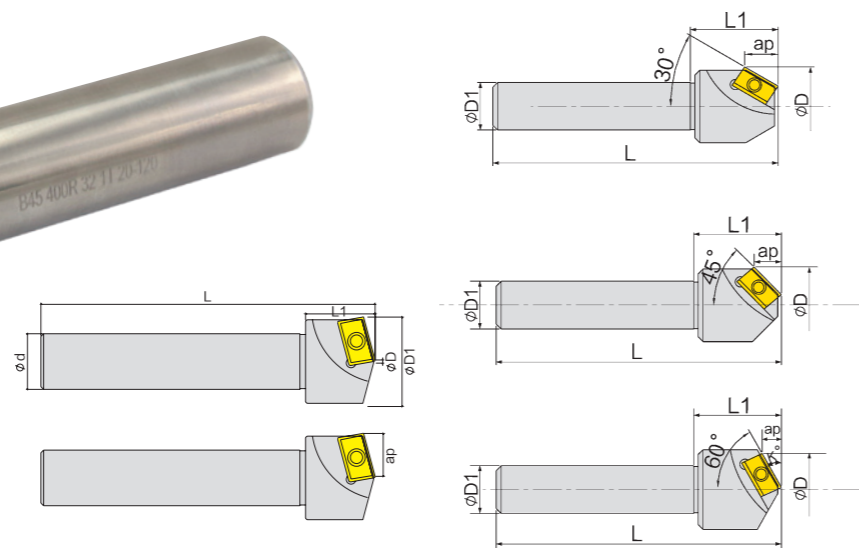
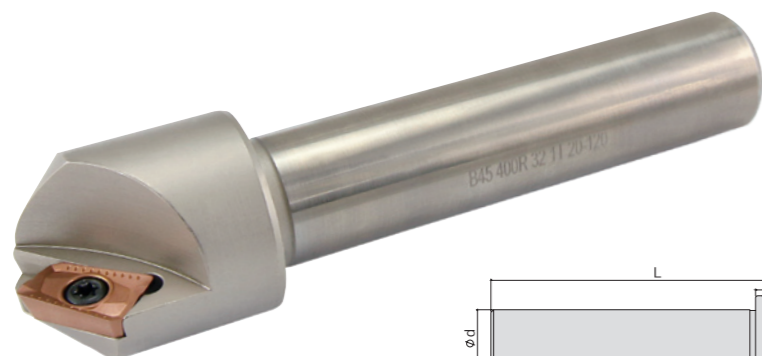

型号 Model	刃数 Blade number		D	D1	d	L	L1	ap	K°	螺丝 Screw	扳手 Wrench
B15AP16-1T-S20-120	1	AP1604	1.2	32	20	120	25	15.4	15	M4*9	T15
B30AP16-1T-S20-120	1		4.5	32	20	120	25	13.8	30		
B45AP16-1T-S20-120	1		9.6	32	20	120	25	11.2	45		
B60AP16-1T-S20-120	1		16.2	32	20	120	25	7.9	60		

SC 倒角刀系列(多功能)
SC ROSE REAMER SERIES (MULTI-PURPOSE)

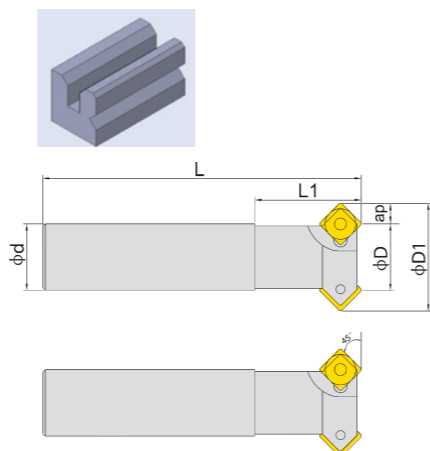

型号 Model	刃数 Blade number		D	D1	d	L	L1	ap	螺丝 Screw	扳手 Wrench
B45SC 091 T20-120	1	SCMT09T304	9	22.6	20	120	40	5	LD533509	T15
B45SC 192 T20-120	2	SCMT09T304	19	32.14	20	120	40	6	LD533509	T15
B45SC 252 T25-120	2	SCMT120408	24	40	25	120	40	14	LD715012	T20

合金防震螺纹铣刀系列
ALLOY SHOCKPROOF THREAD MILLING CUTTER SERIES

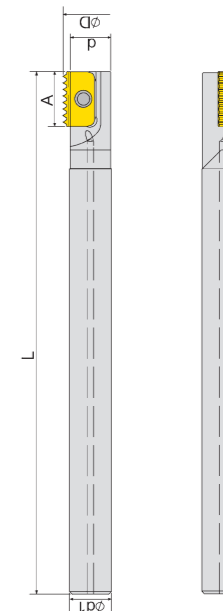

型号 Model		适用条件					螺丝 Screw	扳手 Wrench		
		D	D1	d	L	A				
SR 0810K12C	12 I * ISO MT7	9.9	8	7.8	125	12	LD403007	T-8		
SR 1013M14C	14 I * ISO MT7	13.2	10	9.8	150	14				
SR 1215Q14C	14 I * ISO MT7	15.2	12	11.8	180	14	LD574009	T-15		
SR 1621R21C	21 I * ISO MT7	21	16	15.5	200	21				
SR 2027S30C	30 I * ISO MT7	27	20	19.5	250	30	LD715012	T-20		
● 以下为带内冷										
SR 0810K12C-A	12 I * ISO MT7	9.9	8	7.8	125	12	LD403007	T-8		
SR 1013M14C-A	14 I * ISO MT7	13.2	10	9.8	150	14				
SR 1215Q14C-A	14 I * ISO MT7	15.2	12	11.8	180	14	LD574009	T-15		
SR 1621R21C-A	21 I * ISO MT7	21	16	15.5	200	21				
SR 2027S30C-A	30 I * ISO MT7	27	20	19.5	250	30	LD715012	T-20		

螺纹铣刀系列
THREAD MILLING CUTTER SERIES

螺丝沉头刀
COUNTERSUNK SCREWDRIVER

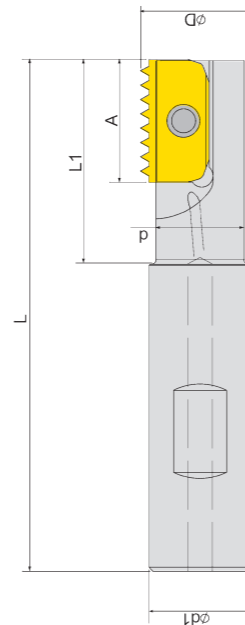

型号 Model	适用条件	适用条件						螺丝 Screw	扳手 Wrench
		D	D1	d	L	L1	A		
SR 2010G12	12 I * ISO MT7	9.9	20	7.6	85	16	12	LD403007	T-8
SR 2012F14	14 I * ISO MT7	12	20	8.9	75	20	14		
SR 2014G14	14 I * ISO MT7	14.5	20	11.2	85	25	14		
SR 2017G14	14 I * ISO MT7	17	20	13.4	85	30	14		
SR 2018G21	21 I * ISO MT7	18	20	14.4	85	30	21		
SR 2021G21	21 I * ISO MT7	21	20	16.5	85	40	21		
SR 2529J30	30 I * ISO MT7	29	25	22.4	110	50	30	LD574009	T-15
SR 4048M40	40 I * ISO MT7	48	40	35	150	78	40		
加长型									
SR 2025K21	21 I * ISO MT7	25	20	-	125	-	21	LD574009	T-15
SR 2531M21	21 I * ISO MT7	31	25	-	150	-	21		
SR 3238M30	30 I * ISO MT7	38	32	-	150	-	30	LD715012	T-20
SR 4048R40	40 I * ISO MT7	48	40	-	200	-	40		
● 以下为带内冷									
SR 2010G12-A	12 I * ISO MT7	9.9	20	7.6	85	16	12	LD403007	T-8
SR 2012F14-A	14 I * ISO MT7	12	20	8.9	75	20	14		
SR 2014G14-A	14 I * ISO MT7	14.5	20	11.2	85	25	14		
SR 2017G14-A	14 I * ISO MT7	17	20	13.4	85	30	14		
SR 2018G21-A	21 I * ISO MT7	18	20	14.4	85	30	21		
SR 2021G21-A	21 I * ISO MT7	21	20	16.5	85	40	21		
SR 2529J30-A	30 I * ISO MT7	29	25	22.4	110	50	30	LD574009	T-15
SR 4048M40-A	40 I * ISO MT7	48	40	35	150	78	40		
加长型									
SR 2025K21-A	21 I * ISO MT7	25	20	-	125	-	21	LD574009	T-15
SR 2531M21-A	21 I * ISO MT7	31	25	-	150	-	21		
SR 3238M30-A	30 I * ISO MT7	38	32	-	150	-	30	LD715012	T-20
SR 4048R40-A	40 I * ISO MT7	48	40	-	200	-	40		

注：螺纹铣刀根据CPT品牌刀片来生产，如装国内其他品牌刀片请试装一下看是否合适

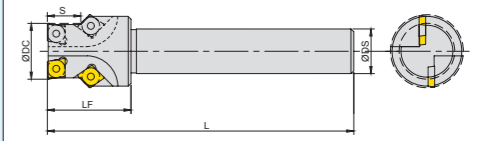
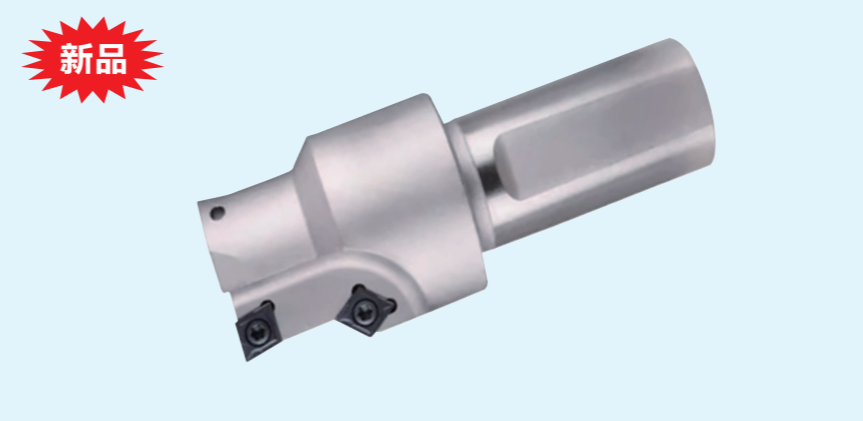

型号 Model	适用条件	适用条件					螺丝 Screw	扳手 Wrench
		φDC	φDS	S	L	LF		
CH-M6-H7-D11-C16-110L	CC0602	11	16	6	110	25	LD35202557 T8-30	T8
CH-M8-H9-D14-C16-110L		14	16	8	110	25		
CH-M10-H11-D17-C16-110L		17	16	10	110	25		
CH-M12-H13-D20-C16-110L		20	16	12	110	30		
CH-M14-H15-D23-C20-120L		23	16	14	120	40		
CH-M16-H17-D26-C25-120L		26	16	16	120	40		
CH-M18-H19-D29-C25-120L		29	16	18	120	40		
CH-M20-H21-D32-C32-120L		32	16	20	120	40		
CH-M24-H25-D39-C32-140L		39	16	24	140	60		
CH-M30-H32-D48-C40-140L		48	16	30	140	60		

A

铣刀系列
Milling cutter series

A

铣刀系列
Milling cutter series

外圆车刀杆识别系统

CYLINDRICAL TOOL ARBOR RECOGNITION SYSTEM

C-type型号	P-type型号	S-type型号
D-type型号	M-type型号	

1	2	3	4	5	6	7	8	9	10
M	C	L	N	R	25	25	M	12	FZ

2 刀片形状	4 刀片后角	5 方向	6 高度(mm)	7 宽度(mm)	8 长度(mm)	9 切刃长
C 四边形 顶角80° D 四边形 顶角55° K 平形四边形 顶角55° R 圆形 S 正方形 T 正三角形 V 四边形 顶角35° W 特殊六角形	C 7° B 5° N 0° P 11°	L N R	H 100 K 125 M 150 P 170 R 200	3 9.525 4 12.7 5 15.875 6 19.05 8 25.4	内切圆直径 (mm) 3 9.525 4 12.7 5 15.875 6 19.05 8 25.4	切刃长 3 9.525 4 12.7 5 15.875 6 19.05 8 25.4

外圆车刀防震系列

OUTSIDE TURNING TOOL SHOCK SERIES



外圆车刀防震系列

TYPE CIRCULAR KNIFE SHOCKPROOF SERIES

目录

95° 外径(B1) CCLNR/L-FZ	95° 外径(B1) CSSNR/L-FZ	45° 外径(B2) CSDNN-FZ	91° 外径(B2) CTGNR/L-FZ	95° 外径(B3) CWLNR/L-FZ
95° 外径(B4) DCLNR/L-FZ	45° 外径(B4) DSSNR/L-FZ	95° 外径(B5) DWLNR/L-FZ	91° 外径(B5) DTGNR/L-FZ	93° 外径(B6) DVJNR/L-FZ
117.5° 外径(B6) DVQNR/L-FZ				

防震刀杆在高速切削的工况下



防震CBN刀杆可根据客户需求定制

CCLNR/L-FZ

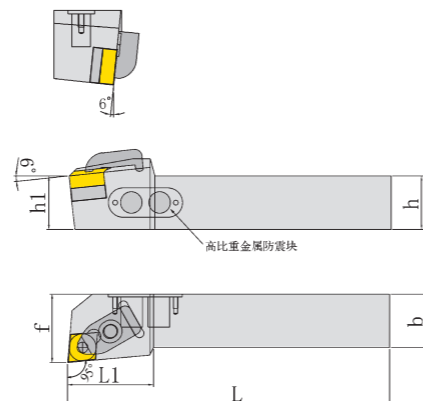

型号 Model		h	b	L	L1	h1	f	刀垫CN Knife pad CN	销钉CXD Pin CXD	压板CYB Pressing plate CYB	固定螺钉NLJ Fixed screw NLJ	弹簧TH Spring TH	扳手 Wrench
CCLNR/L2020K1204-FZ		20	20	125	40	20	25						
CCLNR/L2525M1204-FZ	CN□□1204□□	25	25	150	40	25	32	CN1204					
CCLNR/L3232P1204-FZ		32	32	170	40	32	40						
CCLNR/L2020K1206-FZ		20	20	125	40	20	25						
CCLNR/L2525M1206-FZ	CN□□1206□□	25	25	150	40	25	32	CN1204	CXD0614	CYB3015	NLJ0625	TH0913	L5.0
CCLNR/L3232P1206-FZ		32	32	170	40	32	40						
CCLNR/L2020K1207-FZ	CN□□1204□□	20	20	125	40	20	25	CN1204					
CCLNR/L2525M1207-FZ	CN□□1207□□	25	25	150	40	25	32	CN1207					
CCLNR/L3232P1207-FZ		32	32	170	40	32	40						

CSDNN-FZ

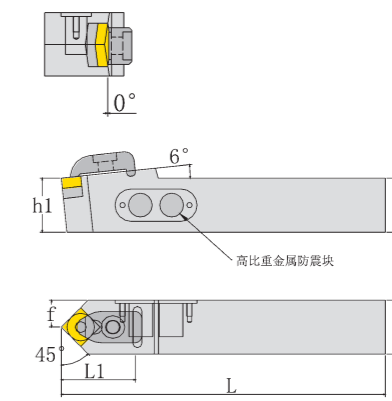

型号 Model		h	b	L	L1	h1	f	刀垫SN Knife pad SN	销钉CXD Pin CXD	压板CYB Pressing plate CYB	固定螺钉NLJ Fixed screw NLJ	弹簧TH Spring TH	扳手 Wrench
CSDNN2020K1204-FZ		20	20	125	43	20	10						
CSDNN2525M1204-FZ	SN□□1204□□	25	25	150	43	25	12.5	SN1204					
CSDNN3232P1204-FZ		32	32	170	43	32	16						
CSDNN2020K1206-FZ		20	20	125	43	20	10						
CSDNN2525M1206-FZ	SN□□1206□□	25	25	150	43	25	12.5	SN1204	CXD0614	CYB3015	NLJ0625	TH0913	L5.0
CSDNN3232P1206-FZ		32	32	170	43	32	16						
CSDNN2020K1207-FZ	SN□□1204□□	20	20	125	43	20	10	SN1204					
CSDNN2525M1207-FZ	SN□□1207□□	25	25	150	43	25	12.5	SN1207					
CSDNN3232P1207-FZ		32	32	170	43	32	16						

CSSNR/L-FZ

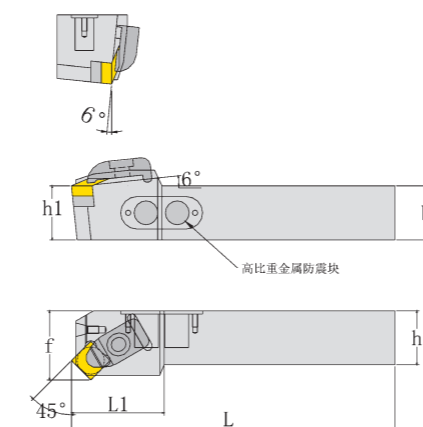

型号 Model		h	b	L	L1	h1	f	刀垫SN Knife pad SN	销钉CXD Pin CXD	压板CYB Pressing plate CYB	固定螺钉NLJ Fixed screw NLJ	弹簧TH Spring TH	扳手 Wrench
CSSNR/L2020K1204-FZ		20	20	125	43	20	25						
CSSNR/L2525M1204-FZ	SN□□1204□□	25	25	150	43	25	32	SN1204					
CSSNR/L3232P1204-FZ		32	32	170	43	32	40						
CSSNR/L2020K1206-FZ		20	20	125	43	20	25						
CSSNR/L2525M1206-FZ	SN□□1206□□	25	25	150	43	25	32	SN1204	CXD0614	CYB3015	NLJ0625	TH0913	L5.0
CSSNR/L3232P1206-FZ		32	32	170	43	32	40						
CSSNR/L2020K1207-FZ	SN□□1204□□	20	20	125	43	20	25	SN1204					
CSSNR/L2525M1207-FZ	SN□□1207□□	25	25	150	43	25	32	SN1207					
CSSNR/L3232P1207-FZ		32	32	170	43	32	40						

CTGNR/L-FZ

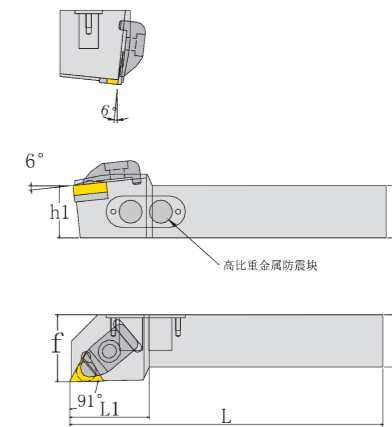

型号 Model		h	b	L	L1	h1	f	刀垫TN Knife pad TN	销钉CXD Pin CXD	压板CYB Pressing plate CYB	固定螺钉NLJ Fixed screw NLJ	弹簧TH Spring TH	扳手 Wrench
CTGNR/L2020K1604-FZ		20	20	125	42	20	25						
CTGNR/L2525M1604-FZ	TN□□1604□□	25	25	150	38	25	32	TN1603+2					
CTGNR/L3232P1604-FZ		32	32	170	38	32	40						
CTGNR/L2020K1606-FZ		20	20	125	42	20	25						
CTGNR/L2525M1606-FZ	TN□□1606□□	25	25	150	38	25	32	TN1603	CXD0512	CYB3015	NLJ0625	TH0913	L5.0
CTGNR/L3232P1606-FZ		32	32	170	38	32	40						

B

外圆车刀防震系列 Type circular knife shockproof series

B

外圆车刀防震系列 Type circular knife shockproof series

CWLNLR/L-FZ

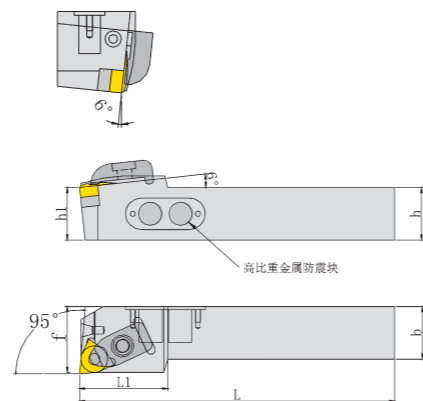

型号 Model		h	b	L	L1	h1	f	刀垫WN Knife pad WN	螺钉 screw	销钉CXD Pin CXD	压板CYB Pressing plate CYB	固定螺钉NLJ Fixed screw NLJ	弹簧TH Spring TH	扳手 Wrench
CWLNLR/L2020K0804-FZ	WN□□0804□□	20	20	125	42	20	25	WN0804						
CWLNLR/L2525M0804-FZ		25	25	150	42	25	32							
CWLNLR/L3232P0804-FZ		32	32	170	42	32	40							
CWLNLR/L4040S0804-FZ	WN□□0806□□	40	40	250	45	40	50	WN0804						
CWLNLR/L2020K0806-FZ		20	20	125	42	20	25							
CWLNLR/L2525M0806-FZ		25	25	150	42	25	32							
CWLNLR/L3232P0806-FZ	32	32	170	42	32	40								
CWLNLR/L4040S0806-FZ	WN□□0804□□	40	40	250	45	40	50	WN0804						
CWLNLR/L2020K0807-FZ		20	20	125	42	20	25							
CWLNLR/L2525M0807-FZ		25	25	150	42	25	32							
CWLNLR/L3232P0807-FZ	32	32	170	42	32	40								
CWLNLR/L4040S0807-FZ	WN□□0807□□	40	40	250	45	40	50	WN0807						

DCLNR/L-FZ

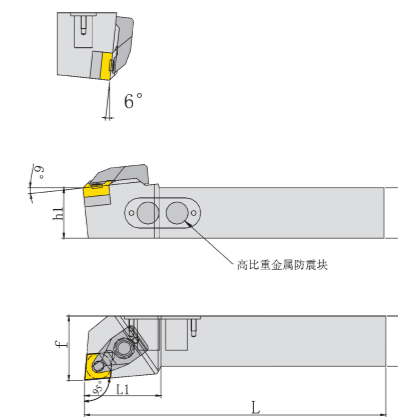

型号 Model		h	b	L	L1	h1	f	刀垫CN Knife pad CN	销钉DXD Pin DXD	压板DYB Pressing plate DYB	固定螺钉NLJ Fixed screw NLJ	弹簧TH Spring TH	扳手 Wrench
DCLNR/L2020K12-FZ	CN□□1204□□	20	20	125	38	20	25	CN1204	DXD0614	DYB2915	NLJ0625	TH0913	L5.0
DCLNR/L2525M12-FZ		25	25	150	38	25	32						
DCLNR/L3232P12-FZ		32	32	170	38	32	40						

DSSNR/L-FZ

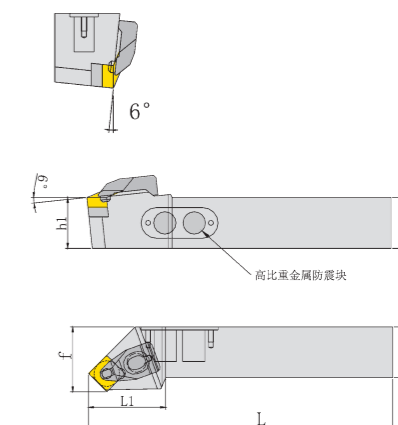

型号 Model		h	b	L	L1	h1	f	刀垫SN Knife pad SN	销钉DXD Pin DXD	压板DYB Pressing plate DYB	固定螺钉NLJ Fixed screw NLJ	弹簧TH Spring TH	扳手 Wrench
DSSNR/L2020K12-FZ	SN□□1204□□	20	20	125	38	20	25	SN1204	DXD0614	DYB2915	NLJ0625	TH0913	L5.0
DSSNR/L2525M12-FZ		25	25	150	38	25	32						
DSSNR/L3232P12-FZ		32	32	170	40	32	40						

DWLNLR/L-FZ

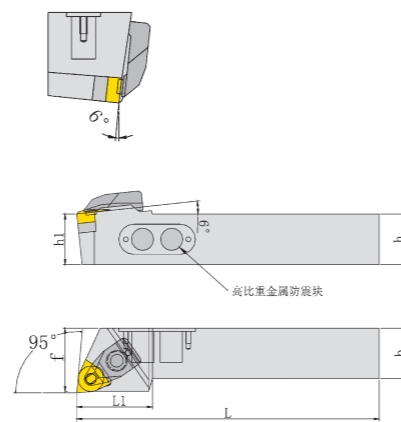

型号 Model		h	b	L	L1	h1	f	刀垫WN Knife pad WN	销钉DXD Pin DXD	压板DYB Pressing plate DYB	固定螺钉NLJ Fixed screw NLJ	弹簧TH Spring TH	扳手 Wrench
DWLNLR/L2020K08-FZ		20	20	125	36	20	25						
DWLNLR/L2525M08-FZ	WN□□0804□□	25	25	150	36	25	32	WN0804	DXD0614	DYB2915	NLJ0625	TH0913	L5.0
DWLNLR/L3232P08-FZ		32	32	170	38	32	40						

DVJNR/L-FZ

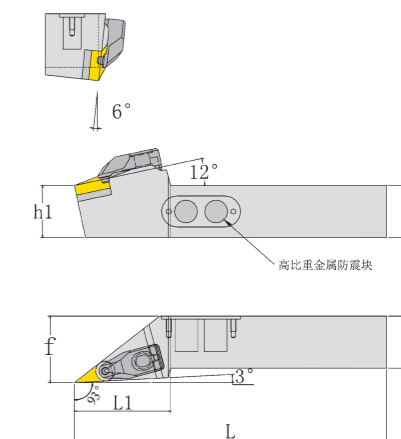

型号 Model		h	b	L	L1	h1	f	刀垫VN Knife pad VN	销钉DXD Pin DXD	压板DYB Pressing plate DYB	固定螺钉NLJ Fixed screw NLJ	弹簧TH Spring TH	扳手 Wrench
DVJNR/L1616H16-FZ		16	16	100	45	16	20						
DVJNR/L2020K16-FZ	VN□□1604□□	20	20	125	47	20	25	VN1603	DXD0512	DYB3113	NLJ0525	TH0814	L4.0
DVJNR/L2525M16-FZ		25	25	150	47	25	32						
DVJNR/L3232P16-FZ		32	32	170	50	32	40						

DTGNR/L-FZ

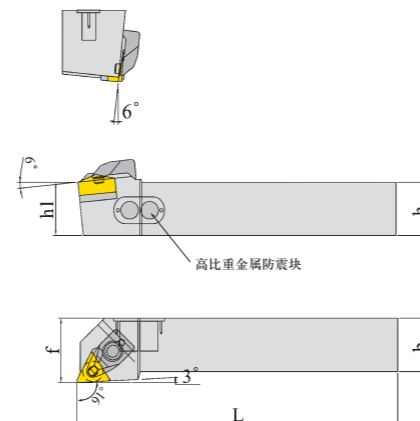

型号 Model		h	b	L	L1	h1	f	刀垫TN Knife pad TN	销钉DXD Pin DXD	压板DYB Pressing plate DYB	固定螺钉NLJ Fixed screw NLJ	弹簧TH Spring TH	扳手 Wrench
DTGNR/L2020K1604-FZ		20	20	125	38	20	25						
DTGNR/L2525M1604-FZ	TN□□1604□□	25	25	150	38	25	32	TN1603	DXD0512	DYB2513	NLJ0525	TH0814	L4.0
DTGNR/L3232P1604-FZ		32	32	170	38	32	40						

DVQNR/L-FZ

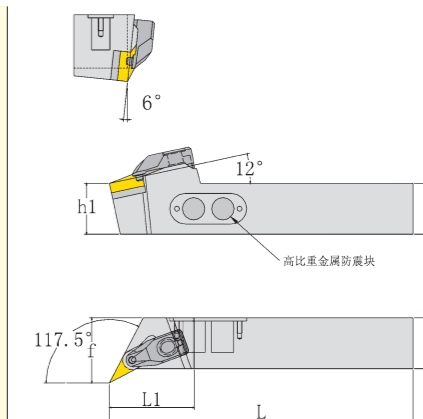

型号 Model		h	b	L	L1	h1	f	刀垫VN Knife pad VN	销钉DXD Pin DXD	压板DYB Pressing plate DYB	固定螺钉NLJ Fixed screw NLJ	弹簧TH Spring TH	扳手 Wrench
DVQNR/L2020K16-FZ		20	20	125	44	20	25						
DVQNR/L2525M16-FZ	VN□□1604□□	25	25	150	44	25	32	VN1603	DXD0512	DYB3113	NLJ0525	TH0814	L4.0
DVQNR/L3232P16-FZ		32	32	170	44	32	40						

M型车刀分解图



D型车刀分解图



1. 装加方便, 稳定性好
2. 适用于重切削







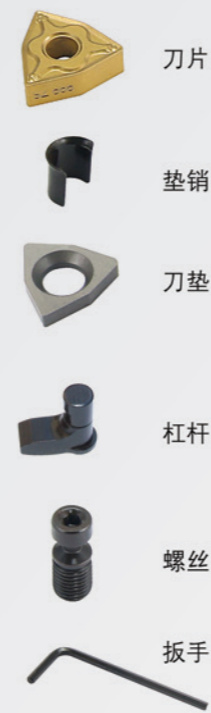











































W型车刀分解图



P型车刀分解图



1. 装加适合不同刀片花纹
装加方便
2. 适用于重切削

95° 外径(C1)  MCLNR/L	95° 外径(C1)  DCLNR/L	95° 外径(C2)  PCLNR/L	95° 外径(C2)  PCLNR/L-A	75° 端面(C3)  MCKNR/L	60° 外径(C16)  MTENN	6° 外径(C17)  PTENR/L	60° 外径(C17)  WTENN	95° 外径(C18)  MWLNR/L	95° 外径(C18)  DWLNR/L
75° 外径(C3)  PCKNR/L	40° 外径(C4)  MCMNN-100	50° 外径(C4)  MCMNN	45° 外径(C5)  MCSNR/L	75° 外径(C5)  MCBNR/L	95° 外径(C19)  PWLNR/L	95° 外径(C19)  PWLNR/L-A	50° 外径(C20)  MWWNN	93° 外径(C20)  MDJNR/L	93° 外径(C21)  DDJNR/L
75° 外径(C6)  PCBNR/L	91° 外径(C6)  MCGNR/L	75° 端面(C7)  MSKNR/L	75° 端面(C7)  PSKNR/L	75° 外径(C8)  MSBNR/L	107.5° 外径(C21)  DDQNR/L	93° 外径(C22)  PDJNR/L	62.5° 外径(C22)  DDPNN	62.5° 外径(C23)  PDPNN	93° 外径(C23)  MVJNR/L
75° 外径(C8)  PSBNR/L	45° 外径(C9)  MSSNR/L	45° 外径(C9)  DSSNR/L	45° 外径(C10)  PSSNR/L	45° 外径(C11)  MSDNN	93° 外径(C24)  DVJNR/L	72.5° 外径(C24)  DVVNN	117.5° 外径(C25)  DVQNR/L	95° 端面(C25)  DVUNR/L	45° 端面(C26)  MHSNR/L
45° 外径(C11)  PSDNN	105° 端面(C12)  MTQNR/L	93° 外径(C12)  MTJNR/L	93° 外径(C13)  DTJNR/L	93° 外径(C13)  WTJNR/L	45° 端面(C26)  DHSNR/L				
93° 外径(C14)  PTJNR/L	93° 外径(C14)  PTJNR/L-A	93° 外径(C15)  MTFNR/L	91° 外径(C15)  MTGNR/L	91° 外径(C16)  PTGNR/L					

MCLNR/L

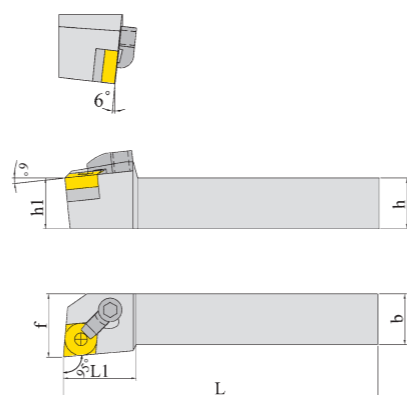

型号 Model		h	b	L	L1	h1	f	刀垫CN Knife pad CN	销钉MXD Pin MXD	压板MYB Pressing plate MYB	双头螺丝ST Double-headed Screw ST	扳手 Wrench
MCLNR/L1616H12	CN□□1204□□	16	16	100	32	16	20	CN1204	MXD0617	MYB1814	ST0625	L2.5
MCLNR/L2020K12		20	20	125	32	20	25					
MCLNR/L2525M12		25	25	150	32	25	32					
MCLNR/L3232P12		32	32	170	32	32	40					

DCLNR/L

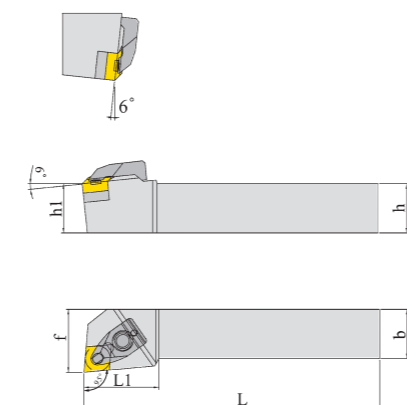

型号 Model		h	b	L	L1	h1	f	刀垫CN Knife pad CN	销钉DXD Pin DXD	压板DYB Pressing plate DYB	固定螺钉NLJ Fixed screw NLJ	弹簧TH Spring TH	扳手 Wrench
DCLNR/L1616H12	CN□□1204□□	16	16	100	35	16	20	CN1204	DXD0614	DXB2413	DGD0525	TH0814	L4.0
DCLNR/L2020K12		20	20	125	35	20	25						
DCLNR/L2525M12		25	25	150	32	25	32						
DCLNR/L3232P12		32	32	170	32	32	40						
DCLNR/L3232P16	CN□□1606□□	32	32	170	40	32	40	CN1604-D	DXD0614	DXB3216	DGD0625	TH0913	L5.0
DCLNR/L3232P19	CN□□1906□□	32	32	170	48	32	40	CN1906-D	DXD0614	DXB3719	DGD0625	TH0913	L5.0
DCLNR/L4040S19	CN□□2509□□	40	40	250	48	40	50	CN2506-D	DXD0614	DXB4523	DGD0830	TH1118	L6.0
DCLNR/L4040S25		40	40	250	56	40	50						
DCLNR/L5050T25	CN□□2509□□	50	50	300	56	50	60						

PCLNR/L

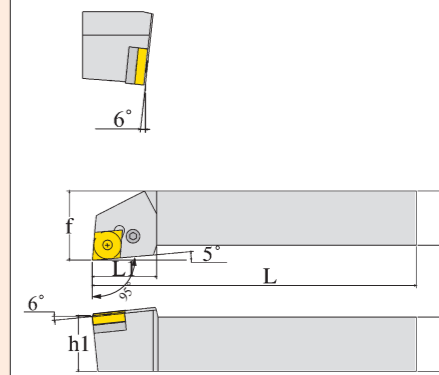

型号 Model		h	b	L	L1	h1	f	杠杆GGX Level GGX	螺丝NLJ-P Screw NLJ-P	垫片CN-P Spacer CN-P	垫销DX Shim DX	扳手 Wrench
PCLNR/L1616H12	CN□□1204□□	16	16	100	28	16	20	GGX0514	NLJ0820-P	CN1203-P	DX0606	L3.0
PCLNR/L2020K12		20	20	125	28	20	25					
PCLNR/L2525M12		25	25	150	28	25	32					
PCLNR/L3232P12		32	32	170	28	32	40					
PCLNR/L2525M16	CN□□1606□□	25	25	150	33	25	32	GGX0617	NLJ0821-P	CN1604-P	DX0808	L3.0
PCLNR/L3232P16	CN□□1906□□	32	32	170	33	32	40	GGX0820	NLJ1027-P	CN1904-P	DX0909	L4.0
PCLNR/L3232P19		32	32	170	40	32	40					
PCLNR/L4040S19	CN□□2509□□	40	40	250	40	40	50	GGX0925	NLJ1237-P	CN2506-P	DX1312	L5.0
PCLNR/L4040S25		40	40	250	47	40	50					
PCLNR/L5050T25	CN□□2509□□	50	50	300	47	50	60					

PCLNR/L-A 内冷款 新品

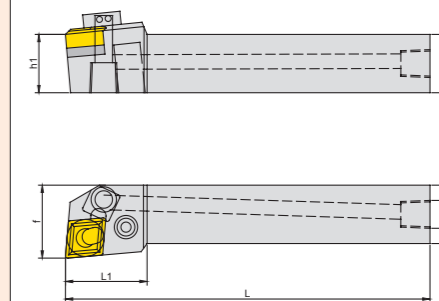

型号 Model		h	b	L	L1	h1	f	杠杆GGX Level GGX	螺丝NLJ-P Screw NLJ-P	垫片CN-P Spacer CN-P	垫销DX Shim DX	弹簧TH Spring TH	扳手 Wrench
PCLNR/L2020K12-A	CN□□1204□□	20	20	125	28	20	25	GGX0516	NLJ0812-P	CN1203-P	DX0606	TH0607	L3.0
PCLNR/L2525M12-A		25	25	150	28	25	32					TH0608	
PCLNR/L3232P12-A		32	32	170	28	32	40						

外圆车刀系列 Type circular knife series

外圆车刀系列 Type circular knife series

MCKNR/L

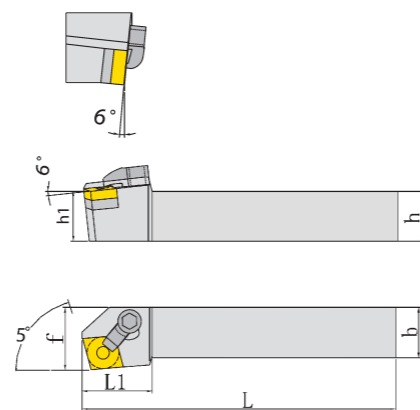

型号 Model		h	b	L	L1	h1	f	刀垫CN Knife pad CN	销钉MXD Pin MXD	压板MYB Pressing plate MYB	双头螺丝ST Double-headed Screw ST	扳手 Wrench
MCKNR/L1616H12	CN□□1204□□	16	16	100	32	16	20	CN1204	MXD0617	MYB1814	ST0625	L2.5 L3.0
MCKNR/L2020K12		20	20	125	32	20	25					
MCKNR/L2525M12		25	25	150	32	25	32					
MCKNR/L3232P12		32	32	170	35	32	40					

MCMNN-100

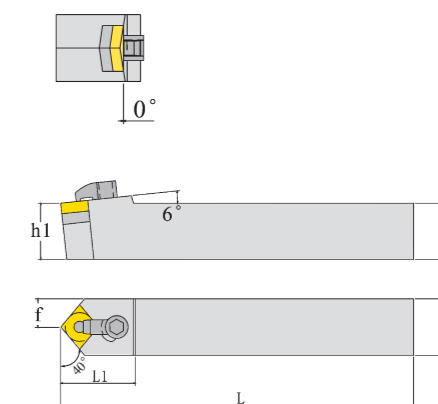

型号 Model		h	b	L	L1	h1	f	刀垫CN Knife pad CN	销钉MXD Pin MXD	压板MYB Pressing plate MYB	双头螺丝ST Double-headed Screw ST	扳手 Wrench
MCMNN1616H12-100	CN□□1204□□	16	16	100	37	16	8	CN1204	MXD0617	MYB1814	ST0625	L2.5 L3.0
MCMNN2020K12-100		20	20	125	37	20	10					
MCMNN2525M12-100		25	25	150	37	25	12.5					
MCMNN3232P12-100		32	32	170	37	32	16					

PCKNR/L

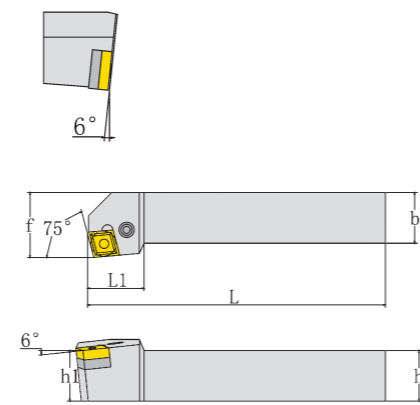

型号 Model		h	b	L	L1	h1	f	杠杆GGX Level GGX	螺丝NLJ-P Screw NLJ-P	垫片CN-P Spacer CN-P	垫销DX Shim DX	扳手 Wrench
PCKNR/L2020K12	CN□□1204□□	20	20	125	28	20	25	GGX0514	NLJ0820-P	CN1203-P	DX0606	L3.0
PCKNR/L2525M12		25	25	150	28	25	32					
PCSKNR/L3232P12	CN□□1606□□	32	32	170	30	32	40	GGX0617	NLJ0821-P	CN1604-P	DX0808	L3.0
PCSKNR/L2525M16		25	25	150	33	25	32					
PCKNR/L3232P16	CN□□1906□□	32	32	170	33	32	40	GGX0820	NLJ1027-P	CN1904-P	DX0909	L4.0
PCKNR/L3232P19		32	32	170	33	32	40					
PCKNR/L4040S19	CN□□2509□□	40	40	250	42	40	50	GGX0925	NLJ1237-P	CN2506-P	DX1312	L5.0
PCKNR/L4040S25		40	40	250	50	40	50					
PCKNR/L5050T25		50	50	300	52	50	60					

MCMNN

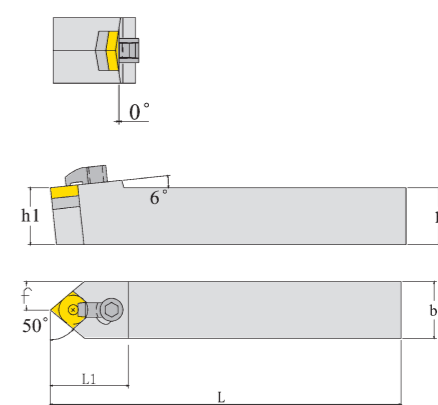

型号 Model		h	b	L	L1	h1	f	刀垫CN Knife pad CN	销钉MXD Pin MXD	压板MYB Pressing plate MYB	双头螺丝ST Double-headed Screw ST	扳手 Wrench
MCMNN1616H12	CN□□1204□□	16	16	100	37	16	8	CN1204	MXD0617	MYB1814	ST0625	L2.5 L3.0
MCMNN2020K12		20	20	125	37	20	10					
MCMNN2525M12		25	25	150	37	25	12.5					
MCMNN3232P12		32	32	170	37	32	16					

C

外圆车刀系列 Type circular knife series

C

外圆车刀系列 Type circular knife series

MCSNR/L

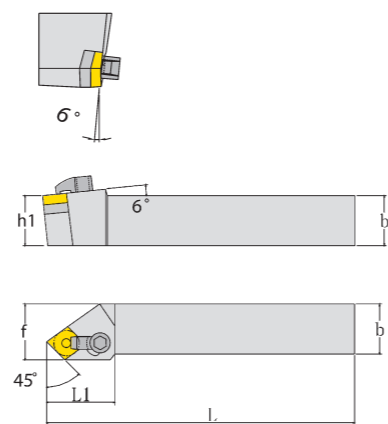

型号 Model		h	b	L	L1	h1	f	刀垫CN Knife pad CN	销钉MXD Pin MXD	压板MYB Pressing plate MYB	双头螺丝ST Double-headed Screw ST	扳手 Wrench
MCSNR/L2020K12		20	20	125	40	20	25					
MCSNR/L2525M12	CN□□1204□□	25	25	150	40	25	32	CN1204	MXD0617	MYB1814	ST0625	L2.5
MCSNR/L3232P12		32	32	170	40	32	40					L3.0

PCBNR/L

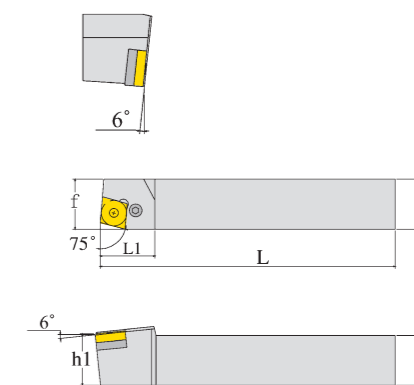

型号 Model		h	b	L	L1	h1	f	杠杆GGX Level GGX	螺丝NLJ-P Screw NLJ-P	垫片CN-P Spacer CN-P	垫销DX Shim DX	扳手 Wrench
PCBNR/L2020K12		20	20	125	27	20	20					
PCBNR/L2525M12	CN□□1204□□	25	25	150	30	25	25	GGX0514	NLJ0820-P	CN1203-P	DX0606	L3.0
PCBNR/L3232P12		32	32	170	30	32	32					
PCBNR/L2525M16		25	25	150	33	25	25					
PCBNR/L3232P16	CN□□1606□□	32	32	170	33	32	32	GGX0617	NLJ0821-P	CN1604-P	DX0808	L3.0
PCBNR/L3232P19		32	32	170	40	32	32					
PCBNR/L4040S19	CN□□1906□□	40	40	250	40	40	40	GGX0820	NLJ1027-P	CN1904-P	DX0909	L4.0
PCBNR/L4040S25		40	40	250	50	40	40					
PCBNR/L5050T25	CN□□2509□□	50	50	300	50	50	50	GGX0925	NLJ1237-P	CN2506-P	DX1312	L5.0

MCBNR/L

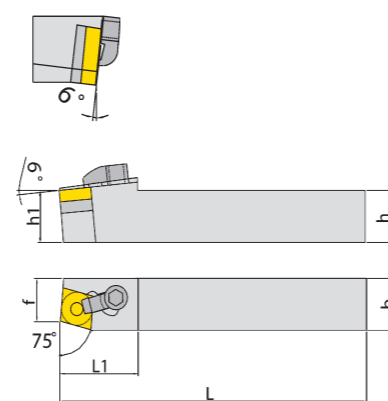

型号 Model		h	b	L	L1	h1	f	刀垫CN Knife pad CN	销钉MXD Pin MXD	压板MYB Pressing plate MYB	双头螺丝ST Double-headed Screw ST	扳手 Wrench
MCBNR/L2020K12		20	20	125	32	20	20					
MCBNR/L2525M12	CN□□1204□□	25	25	150	32	25	25	CN1204	MXD0617	MYB1814	ST0625	L2.5
MCBNR/L3232P12		32	32	170	32	32	32					L3.0

MCGNR/L

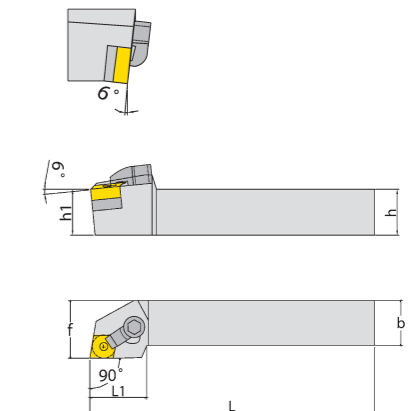

型号 Model		h	b	L	L1	h1	f	刀垫CN Knife pad CN	销钉MXD Pin MXD	压板MYB Pressing plate MYB	双头螺丝ST Double-headed Screw ST	扳手 Wrench
MCGNR/L1616H12		16	16	100	34	16	20					
MCGNR/L2020K12	CN□□1204□□	20	20	125	32	20	25	CN1204	MXD0617	MYB1814	ST0625	L2.5
MCGNR/L2525M12		25	25	150	32	25	32					L3.0
MCGNR/L3232P12		32	32	170	35	32	40					

C

外圆车刀系列 Type circular knife series

C

外圆车刀系列 Type circular knife series

MSKNR/L

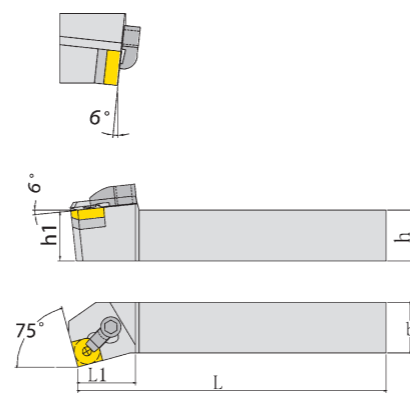

型号 Model		h	b	L	L1	h1	f	刀垫SN Knife pad SN	销钉MXD Pin MXD	压板MYB Pressing plate MYB	双头螺丝ST Double headed Screw ST	扳手 Wrench
MSKNR/L1616H12	SN□□1204□□	16	16	100	36	16	20	SN1204	MXD0617	MYB1814	ST0625	L2.5
MSKNR/L2020K12		20	20	125	32	20	25					
MSKNR/L2525M12		25	25	150	32	25	32					
MSKNR/L3232P12		32	32	170	32	32	40					

MSBNR/L

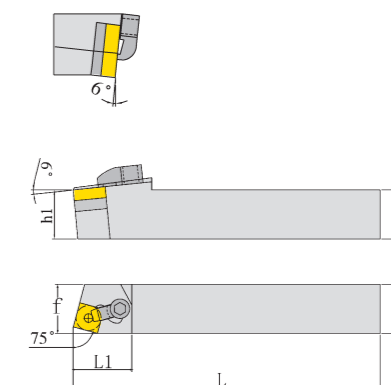

型号 Model		h	b	L	L1	h1	f	刀垫SN Knife pad SN	销钉MXD Pin MXD	压板MYB Pressing plate MYB	双头螺丝ST Double headed Screw ST	扳手 Wrench
MSBNR/L2020K12	SN□□1204□□	20	20	125	35	20	20	SN1204	MXD0617	MYB1814	ST0625	L2.5
MSBNR/L2525M12		25	25	150	37	25	25					
MSBNR/L3232P12		32	32	170	37	32	32					

PSKNR/L

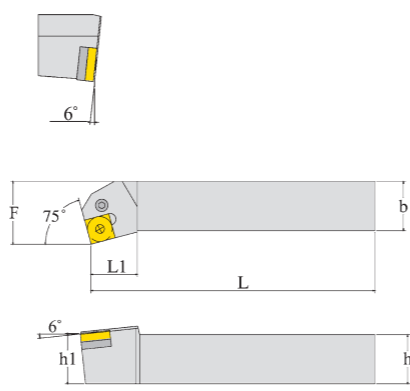

型号 Model		h	b	L	L1	h1	f	杠杆GGX Level GGX	螺丝NLJ-P Screw NLJ-P	垫片SN-P Spacer SN-P	垫销DX Shim DX	扳手 Wrench
PSKNR/L2020K12	SN□□1204□□	20	20	125	28	20	25	GGX0514	NLJ0820-P	SN1203-P	DX0606	L3.0
PSKNR/L2525M12		25	25	150	30	25	32					
PSKNR/L3232P12		32	32	170	30	32	40					
PSKNR/L2525M15	SN□□1506□□	25	25	150	32	25	32	GGX0617	NLJ0821-P	SN1504-P	DX0808	L3.0
PSKNR/L3232P15		32	32	170	32	32	40					
PSKNR/L3232P19	SN□□1906□□	32	32	170	38	32	40	GGX0820	NLJ1027-P	SN1904-P	DX0909	L4.0
PSKNR/L4040S19		40	40	250	38	40	50					
PSKNR/L4040S25	SN□□2509□□	40	40	250	46	40	60	GGX0925	NLJ1237-P	SN2506-P	DX1312	L5.0
PSKNR/L5050T25		50	50	300	50	50	60					

PSBNR/L

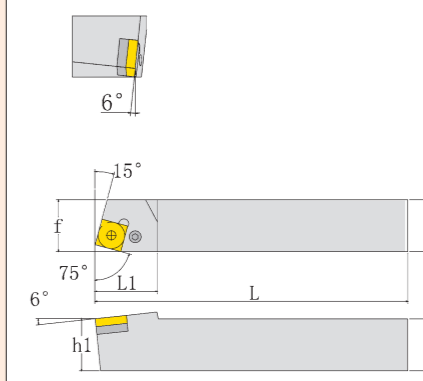

型号 Model		h	b	L	L1	h1	f	杠杆GGX Level GGX	螺丝NLJ-P Screw NLJ-P	垫片SN-P Spacer SN-P	垫销DX Shim DX	扳手 Wrench
PSBNR/L2020K12	SN□□1204□□	20	20	125	28	20	20	GGX0514	NLJ0820-P	SN1203-P	DX0606	L3.0
PSBNR/L2525M12		25	25	150	28	25	25					
PSBNR/L3232P12		32	32	170	28	32	32					
PSBNR/L2525M15	SN□□1506□□	25	25	150	35	25	25	GGX0617	NLJ0821-P	SN1504-P	DX0808	L3.0
PSBNR/L3232P15		32	32	170	35	32	32					
PSBNR/L3232P19	SN□□1906□□	32	32	170	42	32	32	GGX0820	NLJ1027-P	SN1904-P	DX0909	L4.0
PSBNR/L4040S19		40	40	250	42	40	40					
PSBNR/L4040S25	SN□□2509□□	40	40	250	50	40	40	GGX0925	NLJ1237-P	SN2506-P	DX1312	L5.0
PSBNR/L5050T25		50	50	300	50	50	50					

C

外圆车刀系列 Type circular knife series

C

外圆车刀系列 Type circular knife series

MSSNR/L

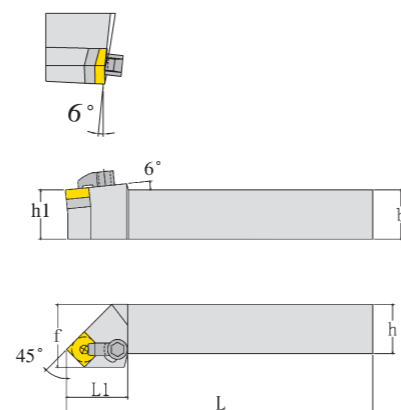

型号 Model		h	b	L	L1	h1	f	刀垫SN Knife pad SN	销钉MXD Pin MXD	压板MYB Pressing plate MYB	双头螺丝ST Double headed Screw ST	扳手 Wrench
MSSNR/L2020K12		20	20	125	35	20	25					
MSSNR/L2525M12	SN□□1204□□	25	25	150	35	25	32	SN1204	MXD0617	MYB1814	ST0625	L2.5
MSSNR/L3232P12		32	32	170	35	32	40					L3.0

PSSNR/L

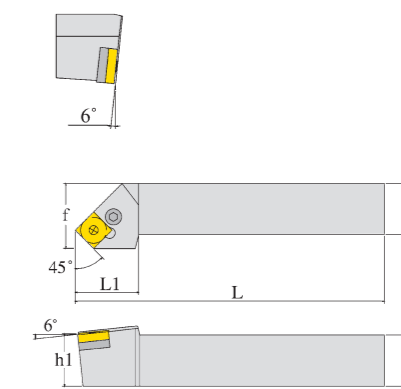

型号 Model		h	b	L	L1	h1	f	杠杆GGX Level GGX	螺丝NLJ-P Screw NLJ-P	垫片SN-P Spacer SN-P	垫销DX Shim DX	扳手 Wrench
PSSNR/L2020K12		20	20	125	30	20	25					
PSSNR/L2525M12	SN□□1204□□	25	25	150	30	25	32	GGX0514	NLJ0820-P	SN1203-P	DX0606	L3.0
PSSNR/L3232P12		32	32	170	32	32	40					
PSSNR/L2525M15		25	25	150	36	25	32					
PSSNR/L3232P15	SN□□1506□□	32	32	170	36	32	40	GGX0617	NLJ0821-P	SN1504-P	DX0808	L3.0
PSSNR/L3232P19		32	32	170	42	32	40					
PSSNR/L4040S19	SN□□1906□□	40	40	250	42	40	50	GGX0820	NLJ1027-P	SN1904-P	DX0909	L4.0
PSSNR/L4040S25		40	40	250	52	40	50					
PSSNR/L5050T25	SN□□2509□□	50	50	300	52	50	60	GGX0925	NLJ1237-P	SN2506-P	DX1312	L5.0

DSSNR/L

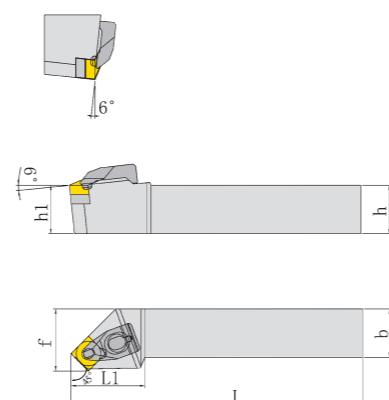

型号 Model		h	b	L	L1	h1	f	刀垫SN Knife pad SN	销钉DXD Pin DXD	压板DYB Pressing plate DYB	固定螺钉NLJ Fixed screw NLJ	弹簧TH Spring TH	扳手 Wrench
DSSNR/L2020K12		20	20	125	38	20	25						
DSSNR/L2525M12	SN□□1204□□	25	25	150	38	25	32	SN1204	DXD0614	DYD2413	DGD0525	TH0814	L4.0
DSSNR/L3232P12		32	32	170	40	32	40						

C

外圆车刀系列 Type circular knife series

C

外圆车刀系列 Type circular knife series

MSDNN

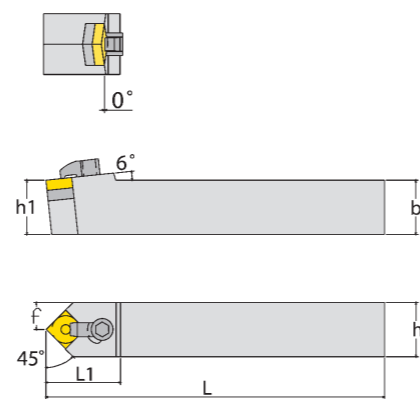

型号 Model		h	b	L	L1	h1	f	刀垫SN Knife pad SN	销钉MXD Pin MXD	压板MYB Pressing plate MYB	双头螺丝ST Double headed Screw ST	扳手 Wrench
MSDNN1616H12	SN□□1204□□	16	16	100	36	16	8	SN1204	MXD0617	MYB1814	ST0625	L2.5
MSDNN2020K12		20	20	125	36	20	10					
MSDNN2525M12		25	25	150	36	25	12.5					
MSDNN3232P12		32	32	170	36	32	16					

PSDNN

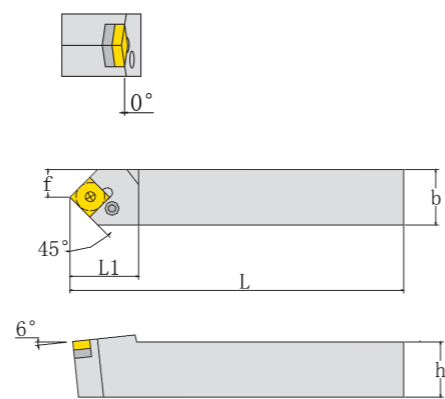

型号 Model		h	b	L	L1	h1	f	杠杆GGX Level GGX	螺丝NLJ-P Screw NLJ-P	垫片SN-P Spacer SN-P	垫销DX Shim DX	扳手 Wrench
PSDNN2020K12	SN□□1204□□	20	20	125	30	20	10	GGX0514	NLJ0820-P	SN1203-P	DX0606	L3.0
PSDNN2525M12		25	25	150	30	25	12.5					
PSDNN3232P12		32	32	170	32	32	16					
PSDNN2525M15	SN□□1506□□	25	25	150	36	25	12.5	GGX0617	NLJ0821-P	SN1504-P	DX0808	L3.0
PSDNN3232P15		32	32	170	36	32	16					
PSDNN3232P19	SN□□1906□□	32	32	170	42	32	16	GGX0820	NLJ1027-P	SN1904-P	DX0909	L4.0
PSDNN4040S19		40	40	250	42	40	20					
PSDNN4040S25	SN□□2509□□	40	40	250	52	40	20	GGX0925	NLJ1237-P	SN2506-P	DX1312	L5.0
PSDNN5050T25		50	50	300	52	50	25					

MTQNR/L

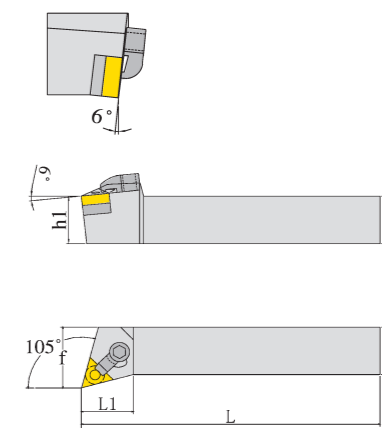

型号 Model		h	b	L	L1	h1	f	刀垫TN Knife pad TN	销钉MXD Pin MXD	压板MYB Pressing plate MYB	双头螺丝ST Double headed Screw ST	扳手 Wrench
MTQNR/L1616H16	TN□□1604□□	16	16	100	30	16	20	TN1603	MXD0513	MYB1814	ST0625	L2.0
MTQNR/L2020K16		20	20	125	30	20	25					
MTQNR/L2525M16		25	25	150	30	25	32					
MTQNR/L3232P16		32	32	170	32	32	40					

MTJNR/L

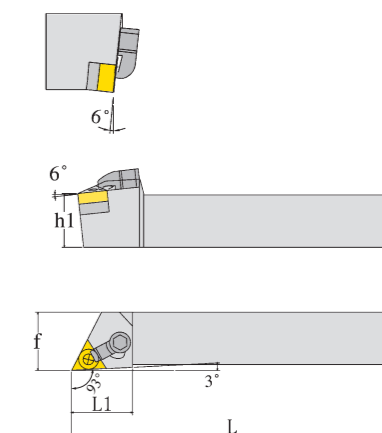

型号 Model		h	b	L	L1	h1	f	刀垫TN Knife pad TN	销钉MXD Pin MXD	压板MYB Pressing plate MYB	双头螺丝ST Double headed Screw ST	扳手 Wrench
MTJNR/L1616H16	TN□□1604□□	16	16	100	33	16	20	TN1603	MXD0513	MYB1814	ST0625	L2.0
MTJNR/L2020K16		20	20	125	33	20	25					
MTJNR/L2525M16		25	25	150	33	25	32					
MTJNR/L3232P16		32	32	170	37	32	40					

C

外圆车刀系列 Type circular knife series

C

外圆车刀系列 Type circular knife series

DTJNR/L

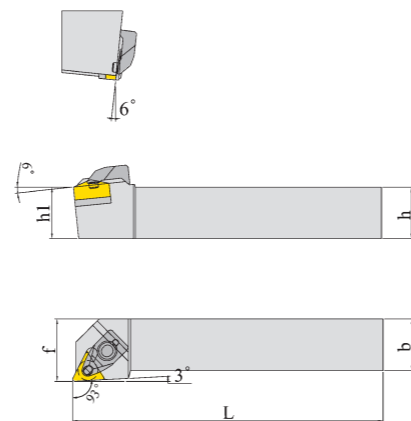

型号 Model		h	b	L	L1	h1	f	刀垫TN Knife pad TN	销钉DXD Pin DXD	压板DYB Pressing plate DYB	固定螺钉NLJ Fixed screw NLJ	弹簧TH Spring TH	扳手 Wrench
DTJNR/L2020K16		20	20	125	30	20	25						
DTJNR/L2525M16	TN□□1604□□	25	25	150	30	25	32	TN1603	DXD0512	DYB2513	DGD0525	TH0814	L4.0
DTJNR/L3232P16		32	32	170	32	32	40						

PTJNR/L

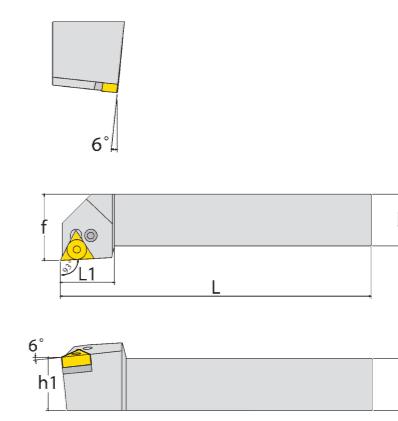

型号 Model		h	b	L	L1	h1	f	杠杆GGX Level GGX	螺丝NLJ-P Screw NLJ-P	垫片TN-P Spacer TN-P	垫销DX Shim DX	扳手 Wrench
PTJNR/L1616H16		16	16	100	22	16	20					
PTJNR/L2020K16		20	20	125	22	20	25	GGX0310	NLJ0618-P	TN1602-P	DX0505	L3.0
PTJNR/L2525M16	TN□□1604□□	25	25	150	28	25	32					
PTJNR/L3232P16		32	25	170	28	32	40					

WTJNR/L

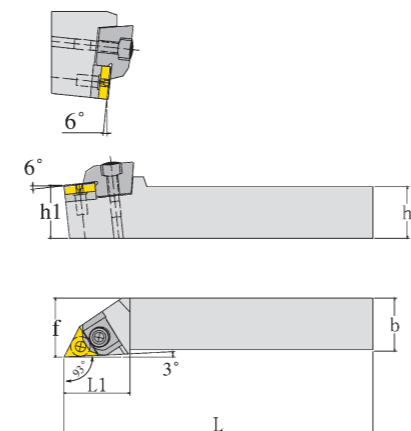

型号 Model		h	b	L	L1	h1	f	刀垫TN Knife pad TN	销钉WXD Pin WXD	压板CYB Pressing plate CYB	固定螺钉NLJ Fixed screw NLJ	弹簧TH Spring TH	扳手 Wrench
WTJNR/L1616H16		16	16	125	33	16	20						
WTJNR/L2020K16		20	20	125	33	20	25	TN1603	WXD0513	WYB1816	NLJ0525	TH0814	L2.5
WTJNR/L2525M16	TN□□1604□□	25	25	150	33	25	32						L4.0
WTJNR/L3232P16		32	32	170	35	32	40						

PTJNR/L-A 内冷款 **新品**

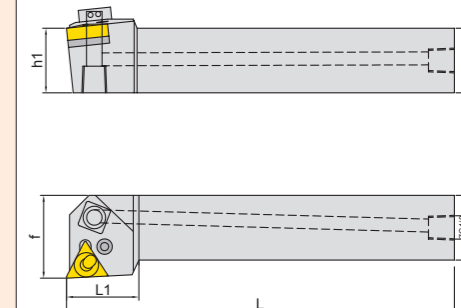

型号 Model		h	b	L	L1	h1	f	杠杆GGX Level GGX	螺丝NLJ-P Screw NLJ-P	垫片TN-P Spacer TN-P	垫销DX Shim DX	弹簧TH Spring TH	扳手 Wrench
PTJNR/L2020K16-A		20	20	125	22	20	25						
PTJNR/L2525M16-A	TN□□1604□□	25	25	150	28	25	32	GGX0313	NLJ0610-P	TN1602-P	DX0505	TH0411	L2.5
PTJNR/L3232P16-A		32	32	170	28	32	40						

C

外圆车刀系列 Type circular knife series

C

外圆车刀系列 Type circular knife series

MTFNR/L

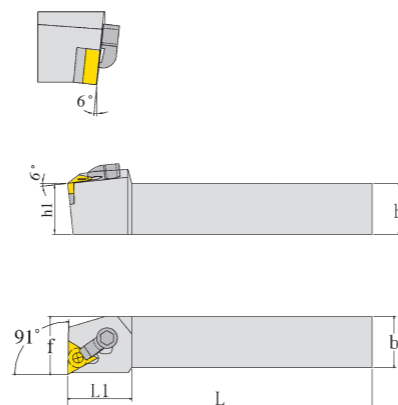

型号 Model		h	b	L	L1	h1	f	刀垫TN Knife pad TN	销钉MXD Pin MXD	压板MYB Pressing plate MYB	双头螺丝ST Double headed Screw ST	扳手 Wrench
MTFNR/L1616H16	TN□□1604□□	16	16	100	32	16	20					
MTFNR/L2020K16		20	20	125	32	20	25	TN1603	MXD0513	MYB1814	ST0625	L2.0
MTFNR/L2525M16		25	25	150	32	25	32					L3.0
MTFNR/L3232P16		32	32	170	35	32	40					

PTGNR/L

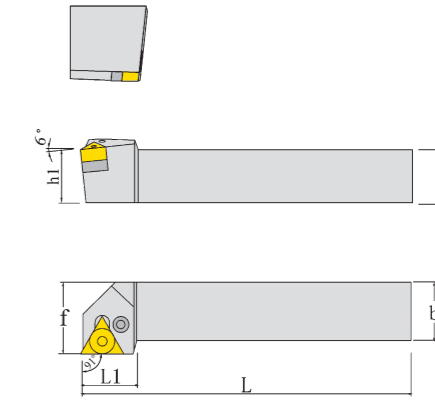

型号 Model		h	b	L	L1	h1	f	刀垫TN Knife pad TN	销钉MXD Pin MXD	压板MYB Pressing plate MYB	双头螺丝ST Double headed Screw ST	扳手 Wrench
PTGNR/L1616H16	TN□□1604□□	16	16	100	22	16	20					
PTGNR/L2020K16		20	20	125	22	20	25					L2.0
PTGNR/L2525M16		25	25	150	28	25	32					L3.0
PTGNR/L3232P16		32	32	170	28	32	40					

MTGNR/L

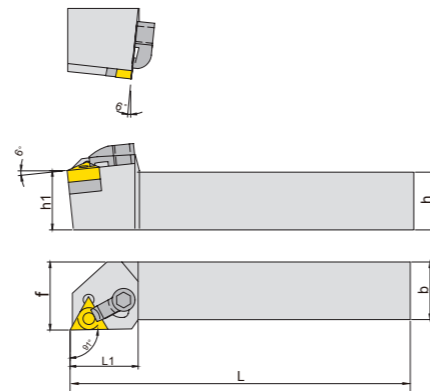

型号 Model		h	b	L	L1	h1	f	刀垫TN Knife pad TN	销钉MXD Pin MXD	压板MYB Pressing plate MYB	双头螺丝ST Double headed Screw ST	扳手 Wrench
MTGNR/L1616H16	TN□□1604□□	16	16	100	32	16	20					
MTGNR/L2020K16		20	20	125	32	20	25	TN1603	MXD0513	MYB1814	ST0625	L2.0
MTGNR/L2525M16		25	25	150	32	25	32					L3.0
MTGNR/L3232P16		32	32	170	35	32	40					

MTENN

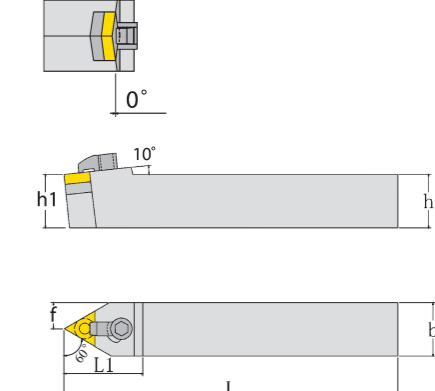

型号 Model		h	b	L	L1	h1	f	刀垫TN Knife pad TN	销钉MXD Pin MXD	压板MYB Pressing plate MYB	双头螺丝ST Double headed Screw ST	扳手 Wrench
MTENN1616H16	TN□□1604□□	16	16	100	35	16	8					
MTENN2020K16		20	20	125	35	20	10	TN1603	MXD0513	MYB1814	ST0625	L2.0
MTENN2525M16		25	25	150	35	25	12.5					L3.0
MTENN3232P16		32	32	170	35	32	16					

C

外圆车刀系列 Type circular knife series

C

外圆车刀系列 Type circular knife series

PTENR/L

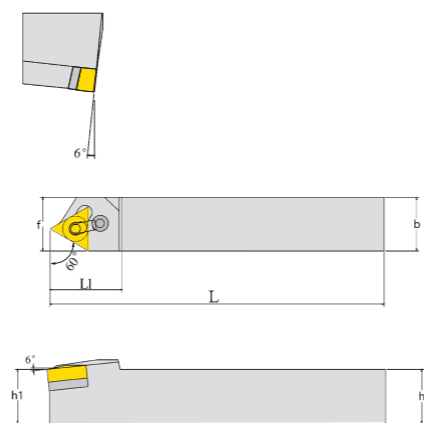

型号 Model		h	b	L	L1	h1	f	杠杆GGX Level GGX	螺丝NLJ-P Screw NLJ-P	垫片TN-P Spacer TN-P	垫销DX Shim DX	扳手 Wrench
PTENR/L2020K16	TN□□1604□□	20	20	125	27	20	20					
PTENR/L2525M16	TN□□1604□□	25	25	150	30	25	25	GGX0310	NLJ0618-P	TN1602-P	DDX0505	L3.0

WTENN

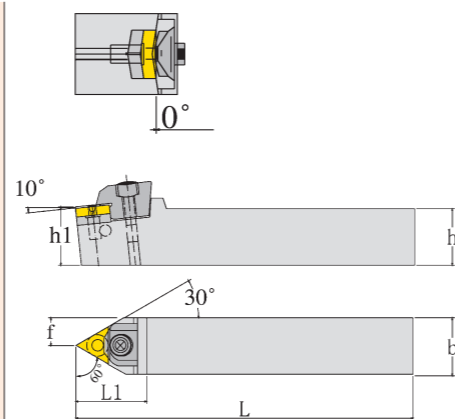

型号 Model		h	b	L	L1	h1	f	刀垫TN Knife pad TN	销钉WXD Pin WXD	压板WYB Pressing plate WYB	固定螺钉NLJ Fixed screw NLJ	弹簧TH Spring TH	扳手 Wrench
WTENN1616H16	TN□□1604□□	16	16	125	33	16	8						
WTENN2020K16	TN□□1604□□	20	20	125	33	20	10	TN1604	WXD0513	WYB1816	NLJ0525	TH0814	L2.5
WTENN2525M16	TN□□1604□□	25	25	150	33	25	12.5						L4.0
WTENN3232P16	TN□□1604□□	32	32	170	33	32	16						

MWLNLR/L

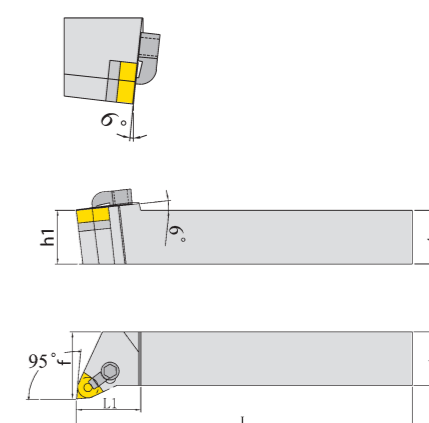

型号 Model		h	b	L	L1	h1	f	刀垫WN Knife pad WN	销钉MXD Pin MXD	压板MYB Pressing plate MYB	双头螺丝ST Double headed Screw ST	扳手 Wrench
MWLNLR/L1616H06	WN□□0604□□	16	16	100	28	16	20					
MWLNLR/L2020K06	WN□□0604□□	20	20	125	28	20	25	WN0603	MXD0513	MYB1814	ST0625	L2.0
MWLNLR/L2525M06	WN□□0604□□	25	25	150	28	25	32					L3.0
MWLNLR/L1616H08	WN□□0804□□	16	16	100	33	16	20					
MWLNLR/L2020K08	WN□□0804□□	20	20	125	29	20	25	WN0804	MXD0617	MYB1814	ST0625	L2.5
MWLNLR/L2525M08	WN□□0804□□	25	25	150	29	25	32					L3.0
MWLNLR/L3232P08	WN□□0804□□	32	32	170	29	32	40					

DWLNLR/L

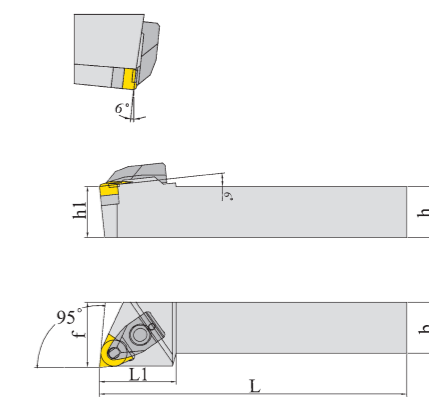

型号 Model		h	b	L	L1	h1	f	刀垫WN Knife pad WN	销钉DXD Pin DXD	压板DYB Pressing plate DYB	固定螺钉NLJ Fixed screw NLJ	弹簧TH Spring TH	扳手 Wrench
DWLNLR/L2020K08	WN□□0804□□	20	20	125	36	20	25						
DWLNLR/L2525M08	WN□□0804□□	25	25	150	32	25	32	WN0804	DXD0614	DYB2413	DGD0525	TH0814	L4.0
DWLNLR/L3232P08	WN□□0804□□	32	32	170	35	32	40						

C

外圆车刀系列 Type circular knife series

C

外圆车刀系列 Type circular knife series

PWLNR/L

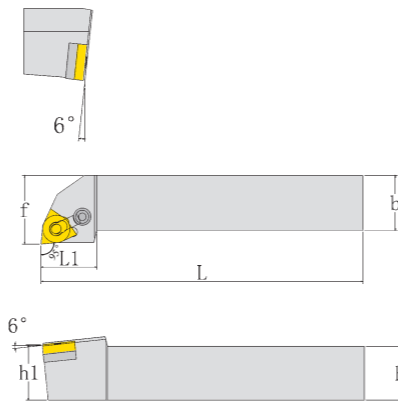

型号 Model		h	b	L	L1	h1	f	杠杆GGX Level GGX	螺丝NLJ-P Screw NLJ-P	垫片WN-P Spacer WN-P	垫销DX Shim DX	扳手 Wrench
PWLNR/L1616H06	WN□□0604□□	16	16	100	20	16	20	GGX0310	NLJ0618-P	WN0602-P	DX0505	L3.0
PWLNR/L2020K06		20	20	125	25	20	25					
PWLNR/L2525M06	WN□□0804□□	25	25	150	25	25	32	GGX0514	NLJ0820-P	WN0803-P	DX0606	L3.0
PWLNR/L1616H08		16	16	100	26	16	20					
PWLNR/L2020K08		20	20	125	26	20	25					
PWLNR/L2525M08		25	25	150	26	25	32					
PWLNR/L3232P08		32	25	170	30	32	40					

MWWNN

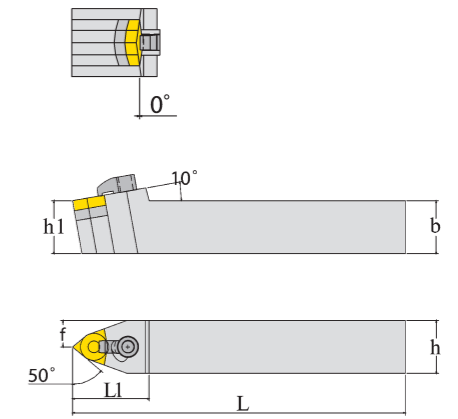

型号 Model		h	b	L	L1	h1	f	刀垫WN Knife pad WN	销钉MXD Pin MXD	压板MYB Pressing plate MYB	双头螺丝ST Double-headed screw ST	扳手 Wrench
MWWNN2020K08	WN□□0804□□	20	20	125	37	20	10	WN0804	MXD0617	MYB1814	ST0625	L2.5
MWWNN2525M08		25	25	150	37	25	12.5					

PWLNR/L-A 内冷款 **新品**

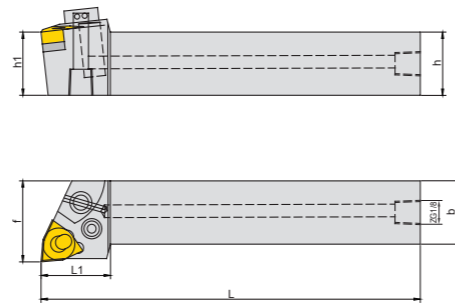

型号 Model		h	b	L	L1	h1	f	杠杆GGX Level GGX	螺丝NLJ-P Screw NLJ-P	垫片WN-P Spacer WN-P	垫销DX Shim DX	弹簧TH Spring TH	扳手 Wrench
PWLNR/L2020K08-A	WN□□0804□□	20	20	125	29	20	25	GGX0516	NLJ0812-P	WN0803-P	DX0606	TH0607	L3.0
PWLNR/L2525M08-A		25	25	150	28	25	32					TH0608	
PWLNR/L3232H08-A		32	32	170	30	32	40						

MDJNR/L

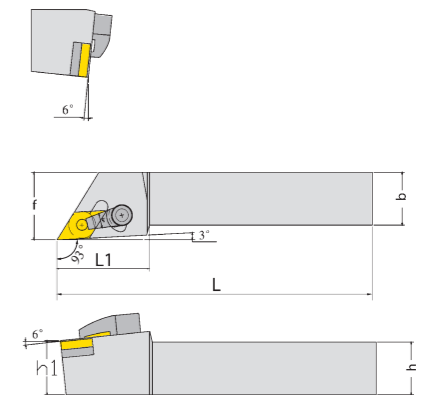

型号 Model		h	b	L	L1	h1	f	刀垫DN Knife pad DN	销钉MXD Pin MXD	压板MYB Pressing plate MYB	双头螺丝ST Double-headed screw ST	扳手 Wrench	
MDJNR/L1616H11	DN□□1104□□	16	16	100	41	16	20	DN1102	MXD0513	MYB1814	ST0625	L2.0	
MDJNR/L2020K11		20	20	125	41	20	25						L3.0
MDJNR/L2525M11		25	25	150	41	25	32						
MDJNR/L2020K15	DN□□1504□□ DN□□1506□□	20	20	125	41	20	25	DN1504 DN1506	MXD0619	MYB2214	ST0625	L2.5	
MDJNR/L2525M15		25	25	150	41	25	32						L3.0
MDJNR/L3232P15		32	32	170	41	32	40						

D型刀片分1504和1506为通用刀杆，在选配时请自己注明型号

C

外圆车刀系列 Type circular knife series

C

外圆车刀系列 Type circular knife series

DDJNR/L

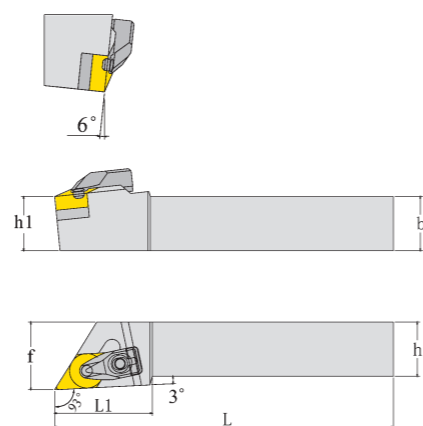

型号 Model		h	b	L	L1	h1	f	刀垫DN Knife pad DN	销钉DXD Pin DXD	压板DYB Pressing plate DYB	固定螺钉NLJ Fixed screw NLJ	弹簧TH Spring TH	扳手 Wrench
DDJNR/L2020K1504		20	20	125	39	20	25	DN1504	DXD0614	DYB2813	DGD0525	TH0814	L4.0
DDJNR/L2525M1504	DN□□1504□□	25	25	150	39	25	32						
DDJNR/L3232P1504		32	32	170	39	32	40						
DDJNR/L2020K1506		20	20	125	39	20	25						
DDJNR/L2525M1506	DN□□1506□□	25	25	150	39	25	32	DN1506 DN1504					
DDJNR/L3232P1506		32	32	170	39	32	40						
DDJNR/L2020K15	DN□□1504□□ DN□□1506□□	20	20	125	39	20	25						
DDJNR/L2525M15		25	25	150	39	25	32						
DDJNR/L3232P15		32	32	170	39	32	40						

D型刀片分1504和1506为通用刀杆，在选配时请自己注明型号

DDQNR/L

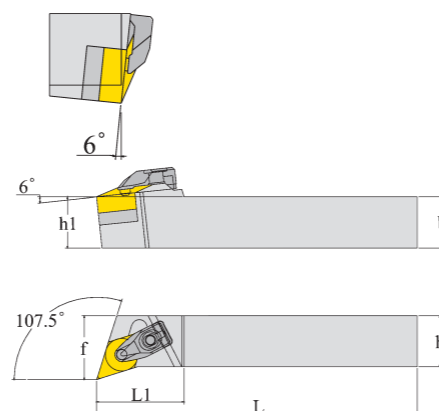

型号 Model		h	b	L	L1	h1	f	刀垫DN Knife pad DN	销钉DXD Pin DXD	压板DYB Pressing plate DYB	固定螺钉NLJ Fixed screw NLJ	弹簧TH Spring TH	扳手 Wrench
DDQNR/L2020K15		20	20	125	39	20	25	DN1506 DN1504	DXD0614	DYB2813	DGD0525	TH0814	L4.0
DDQNR/L2525M15	DN□□1504□□ DN□□1506□□	25	25	150	39	25	32						
DDQNR/L3232P15		32	32	170	39	32	40						

D型刀片分1504和1506为通用刀杆，在选配时请自己注明型号

PDJNR/L

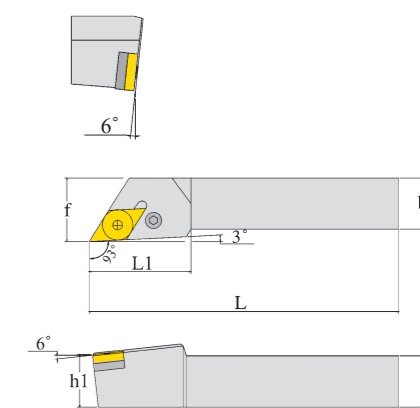

型号 Model		h	b	L	L1	h1	f	刀垫DN Knife pad DN	销钉DXD Pin DXD	压板DYB Pressing plate DYB	固定螺钉NLJ Fixed screw NLJ	弹簧TH Spring TH	扳手 Wrench
PDJNR/L1616H11		16	16	100	28	16	20	DN□□1104□□					
PDJNR/L2020K11		20	20	125	28	20	25						
PDJNR/L2525M11		25	25	150	28	25	32						
PDJNR/L1616H1504		16	16	100	35	16	20	DN□□1504□□					
PDJNR/L2020K1504		20	20	125	35	20	25						
PDJNR/L2525M1504		25	25	150	35	25	32						
PDJNR/L3232P1504		32	32	170	40	32	40						
PDJNR/L1616H1506		16	16	100	35	16	20	DN□□1506□□					
PDJNR/L2020K1506		20	20	125	35	20	25						
PDJNR/L2525M1506		25	25	150	35	25	32						
PDJNR/L3232P1506		32	32	170	40	32	40						

型号 Model	杠杆GGX Level GGX	螺丝NLJ-P Screw NLJ-P	垫片DN-P Spacer DN-P	垫销DX Shim DX	扳手 Wrench
GGX0312	NLJ0618-P	DN1102-P	DX0505	L3.0	
GGX0514	NLJ0820-P	CN1503-P	DX0606	L3.0	
GGX0514D	NLJ0821-P	DN1503-P	DX0606	L3.0	

DDPNN

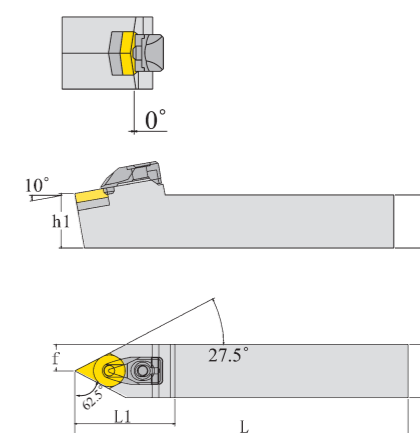

型号 Model		h	b	L	L1	h1	f	刀垫DN Knife pad DN	销钉DXD Pin DXD	压板DYB Pressing plate DYB	固定螺钉NLJ Fixed screw NLJ	弹簧TH Spring TH	扳手 Wrench
DDPNN2020K15		20	20	125	45	20	10	DN1506 DN1504	DXD0614	DYB3113	DGD0525	TH0814	L4.0
DDPNN2525M15	DN□□1504□□ DN□□1506□□	25	25	150	45	25	12.5						
DDPNN3232P15		32	32	170	45	32	16						

D型刀片分1504和1506为通用刀杆，在选配时请自己注明型号

C

外圆车刀系列 Type circular knife series

C

外圆车刀系列 Type circular knife series

PDPNN

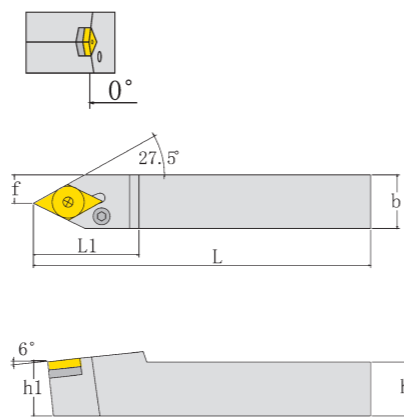

型号 Model		h	b	L	L1	h1	f	杠杆GGX Level GGX	螺丝NLJ-P Screw NLJ-P	垫片DN-P Spacer DN-P	垫销DX Shim DX	扳手 Wrench
PDPNN1616H11	DN□□1104□□	16	16	100	28	16	8	GGX0310	NLJ0618-P	DN1102-P	DX0505	L3.0
PDPNN2020K11	DN□□1104□□	20	20	125	28	20	10	GGX0310	NLJ0618-P	DN1102-P	DX0505	L3.0
PDPNN2525M1504	DN□□1504□□	25	25	150	37	25	12.5	GGX0514	NLJ0820-P	DN1503-P	DX0606	L3.0
PDPNN3232P1504	DN□□1504□□	32	25	170	37	32	16	GGX0514	NLJ0820-P	DN1503-P	DX0606	L3.0
PDPNN2525M1506	DN□□1506□□	25	25	150	37	25	12.5	GGX0514D	NLJ0821-P	DN1503-P	DX0606	L3.0
PDPNN3232P1506	DN□□1506□□	32	25	170	37	32	16	GGX0514D	NLJ0821-P	DN1503-P	DX0606	L3.0

MVJNR/L

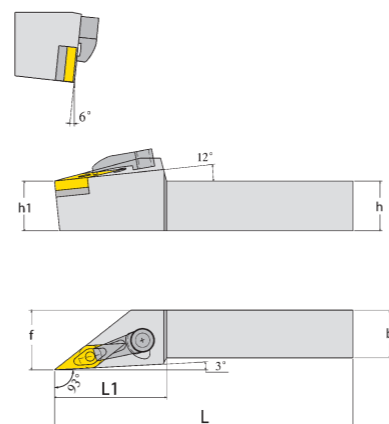

型号 Model		h	b	L	L1	h1	f	刀垫VN Knife pad VN	销钉MXD Pin MXD	压板MYB Pressing plate MYB	双头螺丝ST Double-headed Screw ST	扳手 Wrench
MVJNR/L1616H16	VN□□1604□□	16	16	100	47	16	20	VN1603	MXD0513	MYB2614	ST0625	L2.5
MVJNR/L2020K16	VN□□1604□□	20	20	125	47	20	25	VN1603	MXD0513	MYB2614	ST0625	L2.5
MVJNR/L2525M16	VN□□1604□□	25	25	150	47	25	32	VN1603	MXD0513	MYB2614	ST0625	L3.0
MVJNR/L3232P16	VN□□1604□□	32	32	170	50	32	40	VN1603	MXD0513	MYB2614	ST0625	L3.0

DVJNR/L

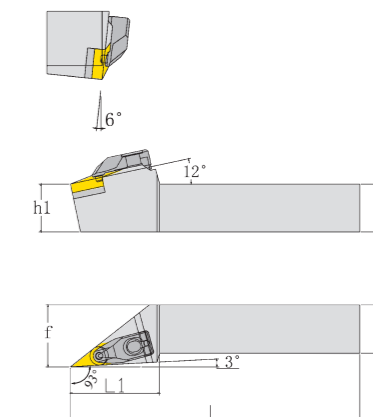

型号 Model		h	b	L	L1	h1	f	刀垫VN Knife pad VN	销钉DXD Pin DXD	压板DYB Pressing plate DYB	固定螺钉NLJ Fixed screw NLJ	弹簧TH Spring TH	扳手 Wrench
DVJNR/L1616H16	VN□□1604□□	16	16	100	47	16	20	VN1603	DXD0512	DYB3113	DGD0525	TH0814	L4.0
DVJNR/L2020K16	VN□□1604□□	20	20	125	47	20	25	VN1603	DXD0512	DYB3113	DGD0525	TH0814	L4.0
DVJNR/L2525M16	VN□□1604□□	25	25	150	47	25	32	VN1603	DXD0512	DYB3113	DGD0525	TH0814	L4.0
DVJNR/L3232P16	VN□□1604□□	32	32	170	50	32	40	VN1603	DXD0512	DYB3113	DGD0525	TH0814	L4.0

DVVNN

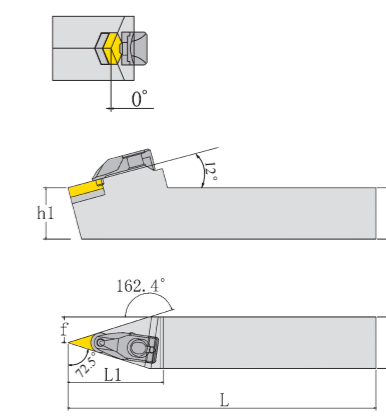
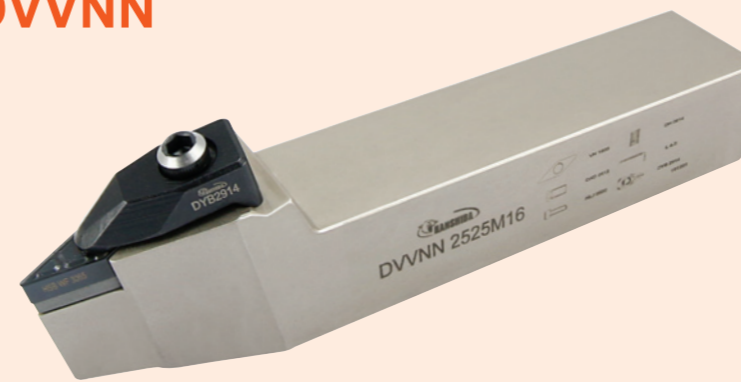

型号 Model		h	b	L	L1	h1	f	刀垫VN Knife pad VN	销钉DXD Pin DXD	压板DYB Pressing plate DYB	固定螺钉NLJ Fixed screw NLJ	弹簧TH Spring TH	扳手 Wrench
DVVNN2020K16	VN□□1604□□	20	20	125	52	20	10	VN1603	DXD0512	DYB3313	DGD0525	TH0814	L4.0
DVVNN2525M16	VN□□1604□□	25	25	150	52	25	12.5	VN1603	DXD0512	DYB3313	DGD0525	TH0814	L4.0
DVVNN3232P16	VN□□1604□□	32	25	170	52	32	16	VN1603	DXD0512	DYB3313	DGD0525	TH0814	L4.0

C

外圆车刀系列 Type circular knife series

C

外圆车刀系列 Type circular knife series

DVQNR/L

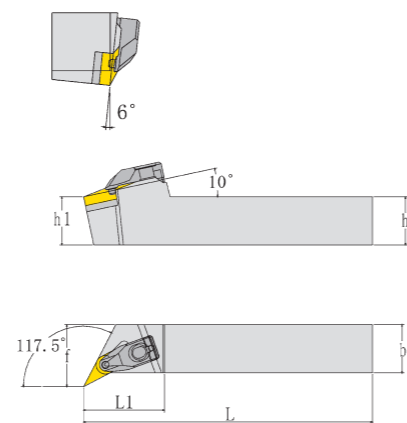

型号 Model		h	b	L	L1	h1	f	刀垫VN Knife pad VN	销钉DXD Pin DXD	压板DYB Pressing plate DYB	固定螺钉NLJ Fixed screw NLJ	弹簧TH Spring TH	扳手 Wrench
DVQNR/L2020K16		20	20	125	44	20	25						
DVQNR/L2525M16	VN□□1604□□	25	25	150	44	25	32	VN1603	DXD0512	DYB3113	DGD0525	TH0814	L4.0
DVQNR/L3232P16		32	32	170	44	32	40						

MHSNR/L

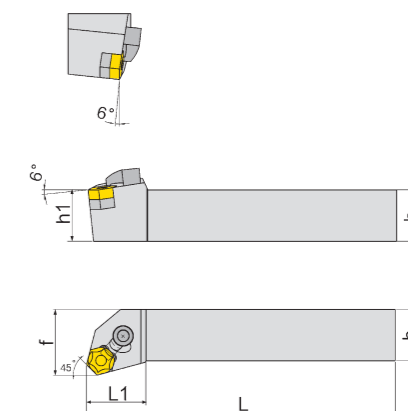

型号 Model		h	b	L	L1	h1	f	刀垫HN Knife pad HN	销钉MXD Pin MXD	压板MYB Pressing plate MYB	双头螺丝ST Double-headed Screw ST	扳手 Wrench
MHSNR/L2020K06		20	20	125	32	20	25					
MHSNR/L2525M06	HN□□0604□□	25	25	150	29	25	32	HN0604	MXD0617	MYB1814	ST0625	L2.5
MHSNR/L3232P06		32	32	170	29	32	40					L3.0

DVUNR/L

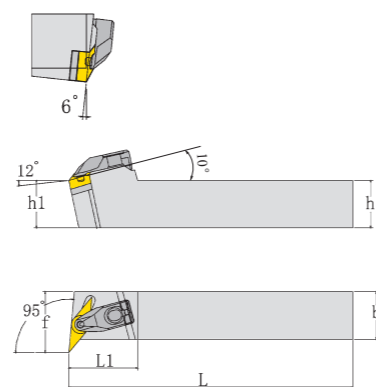

型号 Model		h	b	L	L1	h1	f	刀垫VN Knife pad VN	销钉DXD Pin DXD	压板DYB Pressing plate DYB	固定螺钉NLJ Fixed screw NLJ	弹簧TH Spring TH	扳手 Wrench
DVUNR/L2020K16		20	20	125	38	20	30						
DVUNR/L2525M16	VN□□1604□□	25	25	150	38	25	32	VN1603	DXD0512	DYB3113	DGD0525	TH0814	L4.0
DVUNR/L3232P16		32	32	170	38	32	40						

DHSNR/L

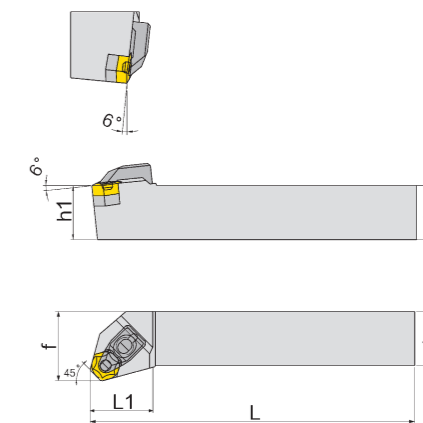

型号 Model		h	b	L	L1	h1	f	刀垫HN Knife pad HN	销钉DXD Pin DXD	压板DYB Pressing plate DYB	固定螺钉NLJ Fixed screw NLJ	弹簧TH Spring TH	扳手 Wrench
DHSNR/L2020K06		20	20	125	32	20	25						
DHSNR/L2525M06	HN□□0604□□	25	25	150	30	25	32	HN0604	DXD0614	DYD2413	DGD0520	TH0814	L4.0
DHSNR/L3232P06		32	32	170	30	32	40						

C

外圆车刀系列 Type circular knife series

C

外圆车刀系列 Type circular knife series

外圆刀(螺钉型)

EXCICLE BLADE (SCREW TYPE)

目录

95° 外径(D1) SCLCR/L	75° 端面(D1) SCKCR/L	40° 外径(D2) SCMCN-100	50° 外径(D2) SCMCN	75° 外径(D3) SCBCR/L
90° 外径(D4) SDACR/L	107.5° 外径(D4) SDQCR/L	91° 端面(D5) SDFCR/L	93° 外径(D5) SDJCR/L	62.5° 外径(D6) SDNCN
90° 外径(D7) SSSCR/L	45° 外径(D7) SSDCN	75° 端面(D8) SSKCR/L	75° 外径(D8) SSBCR/L	60° 端面(D9) STWCR/L
91° 端面(D9) STFCR/L	91° 外径(D10) STGCR/L	72.5° 外径(D11) SVVC(B)/N	93° 外径(D11) SVJC(B)/R/L	117.5° 外径(D12) SVQC(B)/R/L
95° 端面(D12) SVUC(B)/R/L	外径(D13) SRAC(P)/R/L	外径(D14) SRDC(P)/N	外径(D15) SRGC(P)/R/L	

SCLCR/L

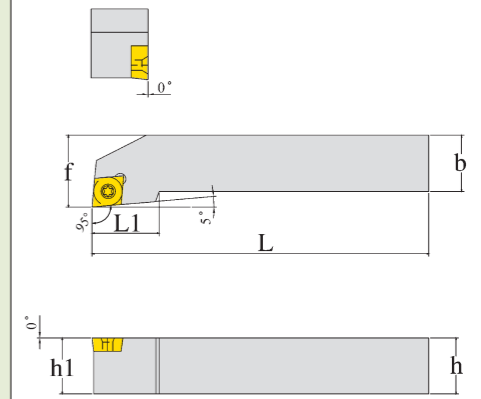

型号 Model		h	b	L	L1	h1	f	螺丝 Screw	扳手 Wrench
SCLCR/L 1010 H06	CC□□0602□□	10	10	100	15	10	12	M2.5*6	T-8
SCLCR/L 1212 H06		12	12	100	15	12	16		
SCLCR/L 1212 H09		12	12	100	20	12	16		
SCLCR/L 1616 H09	CC□□09T3□□	16	16	100	20	16	20	M3.5*8	T-15
SCLCR/L 2020 K09		20	20	125	22	20	25		
SCLCR/L 2525 M09	CC□□1204□□	25	25	150	22	25	32	M5*12	T-20
SCLCR/L 2020 K12		20	20	125	22	20	25		
SCLCR/L 2525 M12		25	25	150	28	25	32		
SCLCR/L 3232 P12		32	32	170	28	32	40		

SCKCR/L

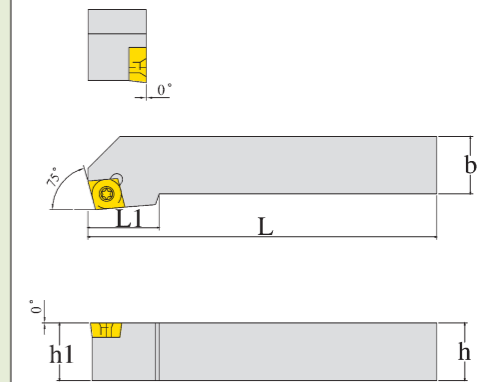

型号 Model		h	b	L	L1	h1	f	螺丝 Screw	扳手 Wrench
SCKCR/L 1212 H09	CC□□09T3□□	12	12	100	20	12	16	M3.5*8	T-15
SCKCR/L 1616 H09		16	16	100	22	16	20		
SCKCR/L 2020 K09		20	20	125	22	20	25		
SCKCR/L 2525 M09	CC□□1204□□	25	25	150	22	25	32	M5*12	T-20
SCKCR/L 2020 K12		20	20	125	22	20	25		
SCKCR/L 2525 M12		25	25	150	22	25	32		
SCKCR/L 3232 P12		32	32	170	28	32	40		

D

外圆刀螺钉型 Excicle Blade (screw type)

SCMCN-100

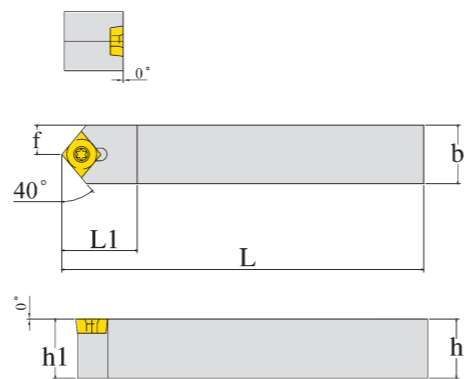

型号 Model		h	b	L	L1	h1	f	螺丝 Screw	扳手 Wrench
SCMCN 1010 H06-100	CC□□0602□□	10	10	100	12	10	5	M2.5*6	T-8
SCMCN 1212 H09-100	CC□□09T3□□	12	12	100	16	12	6	M3.5*8	T-15
SCMCN 1616 H09-100	CC□□09T3□□	16	16	100	18	16	8	M3.5*8	T-15
SCMCN 2020 K12-100	CC□□1204□□	20	20	125	22	20	10	M5*12	T-20
SCMCN 2525 M12-100	CC□□1204□□	25	25	150	28	25	12.5	M5*12	T-20

SCMCN

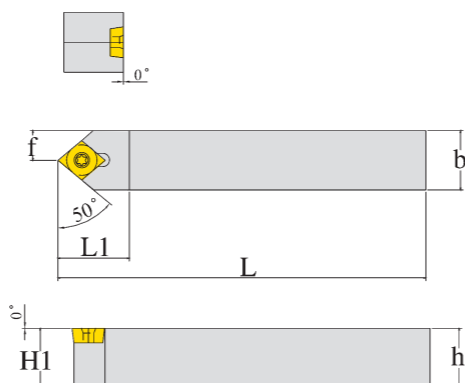

型号 Model		h	b	L	L1	h1	f	螺丝 Screw	扳手 Wrench
SCMCN 1010 H06	CC□□0602□□	10	10	100	15	10	5	M2.5*6	T-8
SCMCN 1212 H09	CC□□09T3□□	12	12	100	20	12	6	M3.5*8	T-15
SCMCN 1616 H09	CC□□09T3□□	16	16	100	20	16	8	M3.5*8	T-15
SCMCN 2020 K12	CC□□1204□□	20	20	125	22	20	10	M5*12	T-20
SCMCN 2525 M12	CC□□1204□□	25	25	150	28	25	12.5	M5*12	T-20

SCBCR/L

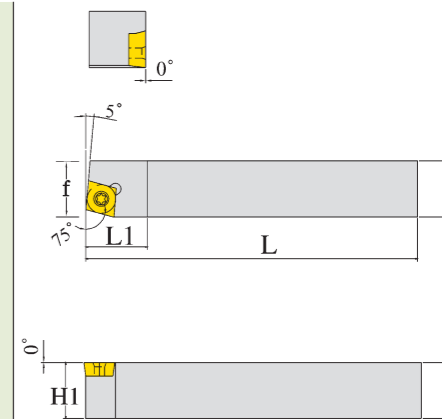

型号 Model		h	b	L	L1	h1	f	螺丝 Screw	扳手 Wrench
SCBCR/L 2020 K09	CC□□09T3□□	20	20	125	22	20	20	M3.5*8	T-15
SCBCR/L 2525 M09	CC□□09T3□□	25	25	150	22	25	25	M3.5*8	T-15
SCBCR/L 2020 K12	CC□□1204□□	20	20	125	22	20	20	M5*12	T-20
SCBCR/L 2525 M12	CC□□1204□□	25	25	150	22	25	25	M5*12	T-20

D

外圆刀螺钉型 Excicle blade (screw type)

D

外圆刀螺钉型 Excicle blade (screw type)

SDACR/L

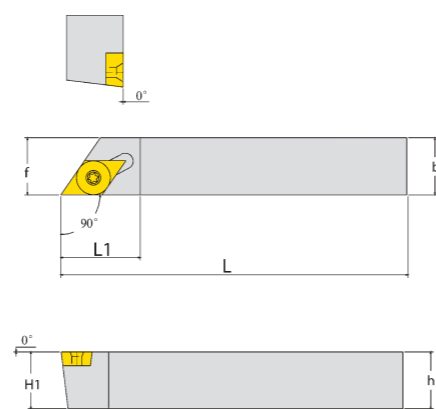

型号 Model		h	b	L	L1	h1	f	螺丝 Screw	扳手 Wrench
SDACR/L 0808 H07	DC□□0702□□	8	8	100	15	8	8	M2.5*6	T-8
SDACR/L 1010 H07		10	10	100	15	10	10		
SDACR/L 1212 H07		12	12	100	15	12	12		
SDACR/L 1212 H11	DC□□11T3□□	12	12	100	22	12	12	M3.5*8	T-15
SDACR/L 1616 H11		16	16	100	22	16	16		
SDACR/L 2020 K11		20	20	125	22	20	20		
SDACR/L 2525 M11		25	25	150	22	25	25		

SDQCR/L

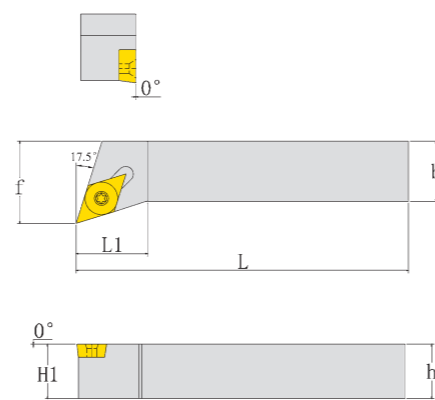

型号 Model		h	b	L	L1	h1	f	螺丝 Screw	扳手 Wrench
SDQCR/L 1010 H07	DC□□0702□□	10	10	100	16	10	12	M2.5*6	T-8
SDQCR/L 1212 H07		12	12	100	16	12	16		
SDQCR/L 1212 H11		12	12	100	18	12	16		
SDQCR/L 1616 H11	DC□□11T3□□	16	16	100	22	16	20	M3.5*8	T-15
SDQCR/L 2020 K11		20	20	125	22	20	25		
SDQCR/L 2525 M11		25	25	150	22	25	32		

SDFCR/L

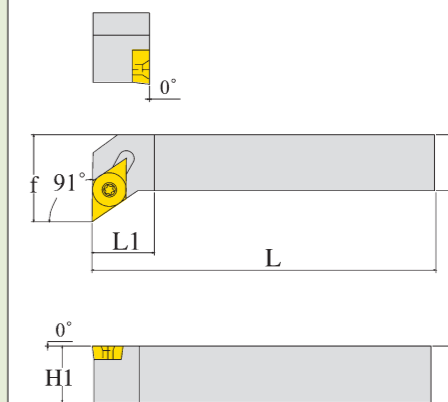

型号 Model		h	b	L	L1	h1	f	螺丝 Screw	扳手 Wrench
SDFCR/L 1212 H07	DC□□0702□□	12	12	100	16	12	16	M2.5*6	T-8
SDFCR/L 1616 H11		16	16	100	18	16	20		
SDFCR/L 2020 K11	DC□□11T3□□	20	20	125	22	20	25	M3.5*8	T-15
SDFCR/L 2525 M11		25	25	150	22	25	32		
SDFCR/L 3232 P11		32	32	170	25	32	40		

SDJCR/L

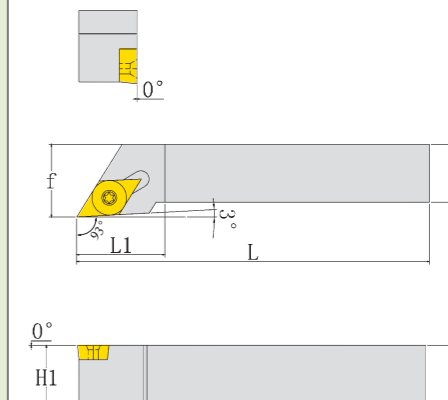

型号 Model		h	b	L	L1	h1	f	螺丝 Screw	扳手 Wrench
SDJCR/L 1010 H07	DC□□0702□□	10	10	100	16	10	12	M2.5*6	T-8
SDJCR/L 1212 H07		12	12	100	16	12	16		
SDJCR/L 1616 H07		16	16	100	20	16	20		
SDJCR/L 1212 H11	DC□□11T3□□	12	12	100	22	12	16	M3.5*8	T-15
SDJCR/L 1616 H11		16	16	100	22	16	20		
SDJCR/L 2020 K11		20	20	125	25	20	25		
SDJCR/L 2525 M11		25	25	150	32	25	32		
SDJCR/L 3232 P11		32	32	170	32	32	40		

D

外圆刀螺钉型 Excicle blade (screw type)

D

外圆刀螺钉型 Excicle blade (screw type)

SDNCN

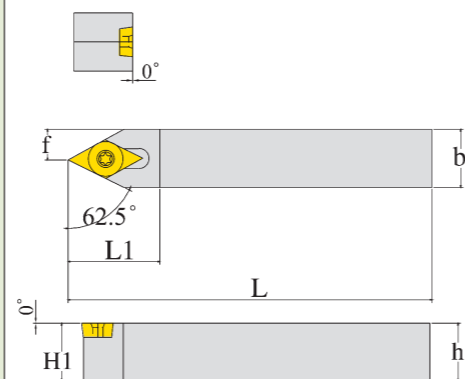

型号 Model		h	b	L	L1	h1	f	螺丝 Screw	扳手 Wrench
SDNCN 0808 K07		8	8	125	16	8	4	M2.5*6	T-8
SDNCN 1010 K07	DC□□0702□□	10	10	125	16	10	5		
SDNCN 1212 K07		12	12	125	18	12	6		
SDNCN 1212 H11		12	12	100	22	12	6	M3.5*8	T-15
SDNCN 1616 H11		16	16	100	27	16	8		
SDNCN 2020 K11	DC□□11T3□□	20	20	125	27	20	10		
SDNCN 2525 M11		25	25	150	27	25	12.5		

SSSCR/L

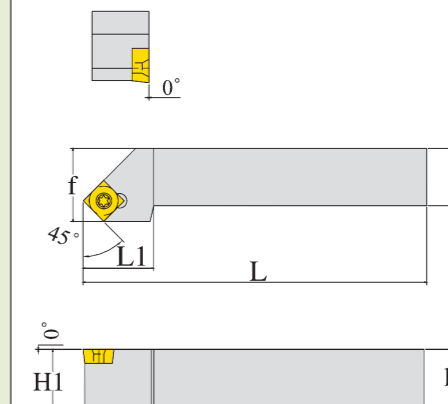

型号 Model		h	b	L	L1	h1	f	螺丝 Screw	扳手 Wrench
SSSCR/L 1212 H09		12	12	100	20	12	16	M3.5*8	T-15
SSSCR/L 1616 H09	SC□□09T3□□	16	16	100	22	16	20		
SSSCR/L 2020 K09		20	20	125	25	20	25		
SSSCR/L 2020 K12		20	20	125	25	20	25	M5*12	T-20
SSSCR/L 2525 M12	SC□□1204□□	25	25	150	30	25	32		

SSDCN

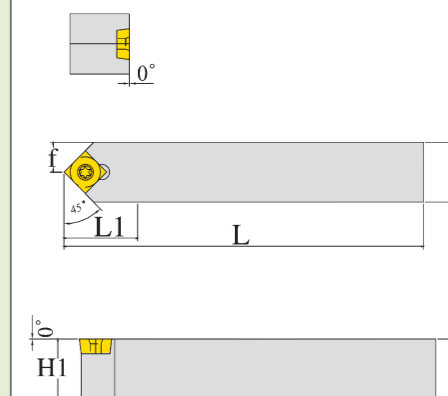

型号 Model		h	b	L	L1	h1	f	螺丝 Screw	扳手 Wrench
SSDCN 1212 H09		12	12	100	16	12	6	M3.5*8	T-15
SSDCN 1616 H09	SC□□09T3□□	16	16	100	20	16	8		
SSDCN 2020 K09		20	20	125	20	20	10		
SSDCN 2020 K12		20	20	125	22	20	10	M5*12	T-20
SSDCN 2525 M12	SC□□1204□□	25	25	150	25	25	12.5		

D

外圆刀螺钉型 Excircle blade (screw type)

D

外圆刀螺钉型 Excircle blade (screw type)

SSKCR/L

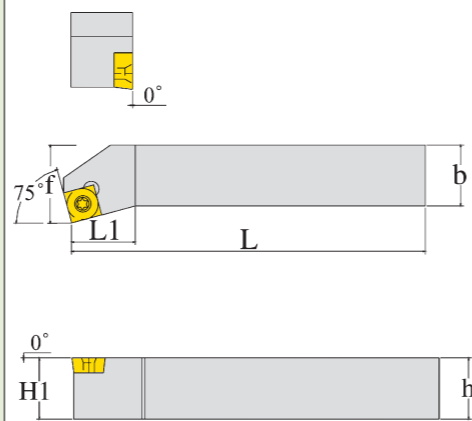

型号 Model		h	b	L	L1	h1	f	螺丝 Screw	扳手 Wrench
SSKCR/L 1212 H09		12	12	100	16	12	16	M3.5*8	T-15
SSKCR/L 1616 H09	SC□□09T3□□	16	16	100	18	16	20		
SSKCR/L 2020 K09		20	20	125	22	20	25	M5*12	T-20
SSKCR/L 2020 K12	SC□□1204□□	20	20	125	22	20	25		
SSKCR/L 2525 M12		25	25	150	30	25	32		

STWCR/L

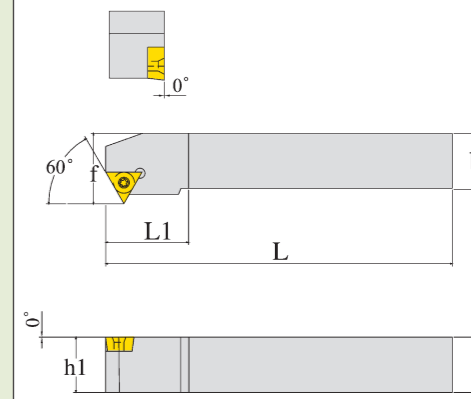

型号 Model		h	b	L	L1	h1	f	螺丝 Screw	扳手 Wrench
STWCR/L 1212 H11		12	12	100	18	12	16	M2.5*6	T-8
STWCR/L 1616 H11	TC□□1102□□	16	16	100	20	16	20		
STWCR/L 2020 K16		20	20	125	23	20	25	M3.5*8	T-15
STWCR/L 2525 M16	TC□□16T3□□	25	25	150	30	25	32		
STWCR/L 3232 P16		32	32	170	30	32	40		

SSBCR/L

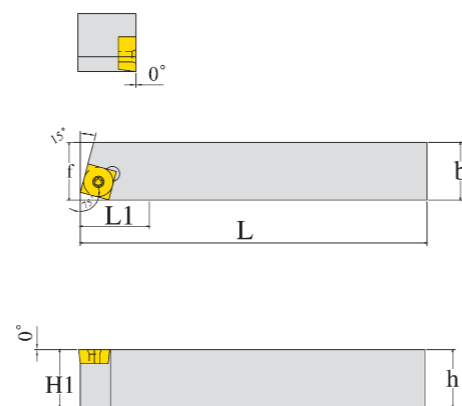

型号 Model		h	b	L	L1	h1	f	螺丝 Screw	扳手 Wrench
SSBCR/L 1212 H09		12	12	100	16	12	12	M3.5*8	T-15
SSBCR/L 1616 H09	SC□□09T3□□	16	16	100	20	16	16		
SSBCR/L 2020 K09		20	20	125	20	20	20	M5*12	T-20
SSBCR/L 2020 K12	SC□□1204□□	20	20	125	20	20	20		
SSBCR/L 2525 M12		25	25	150	25	25	25		

STFCR/L

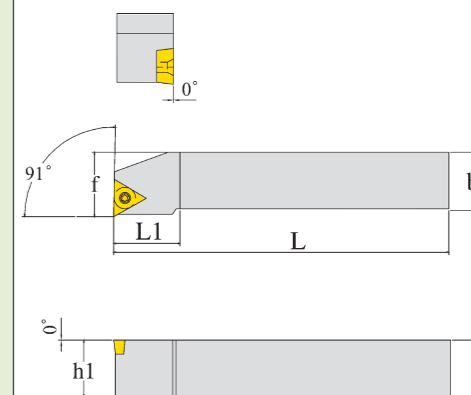

型号 Model		h	b	L	L1	h1	f	螺丝 Screw	扳手 Wrench
STFCR/L 1212 H11		12	12	100	18	12	16	M2.5*6	T-8
STFCR/L 1616 H11	TC□□1102□□	16	16	100	20	16	20		
STFCR/L 2020 K16		20	20	125	23	20	25	M3.5*8	T-15
STFCR/L 2525 M16	TC□□16T3□□	25	25	150	30	25	32		
STFCR/L 3232 P16		32	32	170	30	32	40		

D

外圆刀螺钉型 Excicle blade (screw type)

D

外圆刀螺钉型 Excicle blade (screw type)

STGCR/L

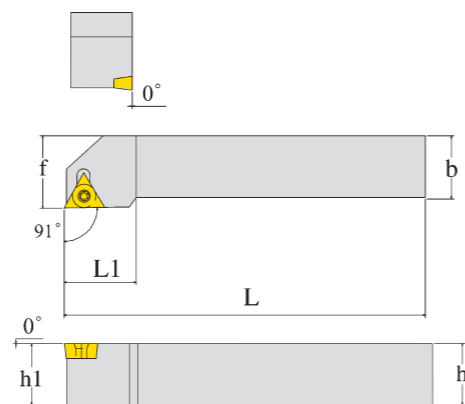

型号 Model		h	b	L	L1	h1	f	螺丝 Screw	扳手 Wrench
STGCR/L 1212 H11		12	12	100	18	12	16	M2.5*6	T-8
STGCR/L 1616 H11	TC□□1102□□	16	16	100	20	16	20		
STGCR/L 2020 K11		20	20	125	23	20	25	M3.5*8	T-15
STGCR/L 2525 M16	TC□□16T3□□	25	25	150	30	25	32		
STGCR/L 3232 P16		32	32	170	30	32	40		

SVVC(B)N

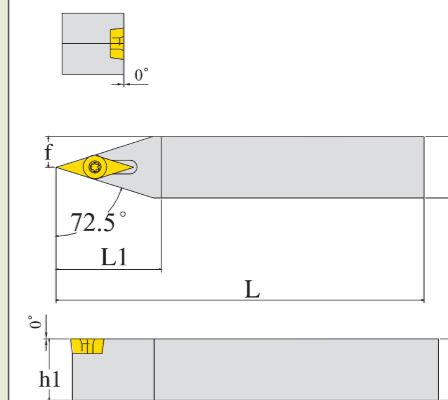

型号 Model		h	b	L	L1	h1	f	螺丝 Screw	扳手 Wrench
SVVC(B)N 1616 H11		16	16	100	28	16	20	M2.5*6	T-8
SVVC(B)N 2020 K11	VC(B)□□1103□□	20	20	125	35	20	25		
SVVC(B)N 2525 M11		25	25	150	35	25	32	M3.5*8	T-15
SVVC(B)N 1616 H16		16	16	100	32	16	20		
SVVC(B)N 2020 K16	VC(B)□□1604□□	20	20	125	35	20	25		
SVVC(B)N 2525 M16		25	25	150	38	25	32		
SVVC(B)N 3232 P16		32	32	170	45	32	40		

SVJC(B)R/L

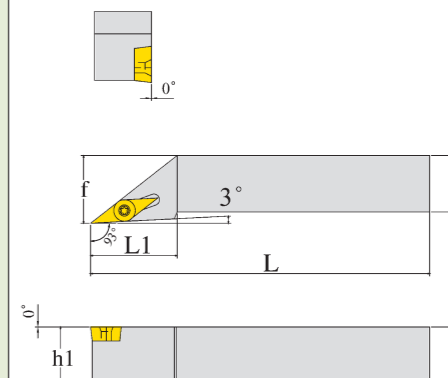

型号 Model		h	b	L	L1	h1	f	螺丝 Screw	扳手 Wrench
SVJC(B)R/L 1212 H11		12	12	100	25	12	16	M2.5*6	T-8
SVJC(B)R/L 1616 H11	VC(B)□□1103□□	16	16	100	28	16	20		
SVJC(B)R/L 2020 K11		20	20	125	35	20	25	M3.5*8	T-15
SVJC(B)R/L 2525 M11		25	25	150	35	25	32		
SVJC(B)R/L 1616 H16		16	16	100	32	16	20		
SVJC(B)R/L 2020 K16	VC(B)□□1604□□	20	20	125	35	20	25		
SVJC(B)R/L 2525 M16		25	25	150	38	25	32		
SVJC(B)R/L 3232 P16		32	32	170	45	32	40		

D

外圆刀螺钉型 Excicle blade (screw type)

D

外圆刀螺钉型 Excicle blade (screw type)

SVQC(B)R/L

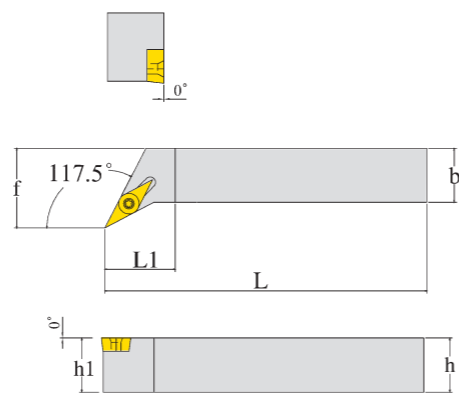

型号 Model		h	b	L	L1	h1	f	螺丝 Screw	扳手 Wrench
SVQC(B)R/L 1616 H11	VC(B)□□1103□□	16	16	100	35	16	20	M2.5*6	T-8
SVQC(B)R/L 2020 K11		20	20	125	35	20	25		
SVQC(B)R/L 1616 H16	VC(B)□□1604□□	25	25	150	35	16	20	M3.5*8	T-15
SVQC(B)R/L 2020 K16		20	20	125	35	20	25		
SVQC(B)R/L 2525 M16		25	25	150	35	25	32		
SVQC(B)R/L 3232 P16		32	32	170	35	32	40		

SVUC(B)R/L

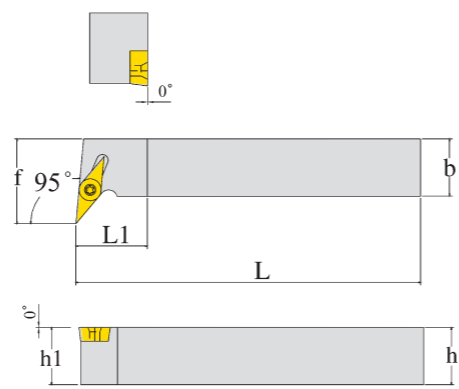

型号 Model		h	b	L	L1	h1	f	螺丝 Screw	扳手 Wrench
SVUC(B)R/L 1616 H11	VC(B)□□1103□□	16	16	100	16	20	20	M2.5*6	T-8
SVUC(B)R/L 2020 K11		20	20	125	16	20	30		
SVUC(B)R/L 2020 K16	VC(B)□□1604□□	20	20	125	16	20	30	M3.5*8	T-15
SVUC(B)R/L 2525 M16		25	25	150	16	25	35		

SRAC(P)R/L

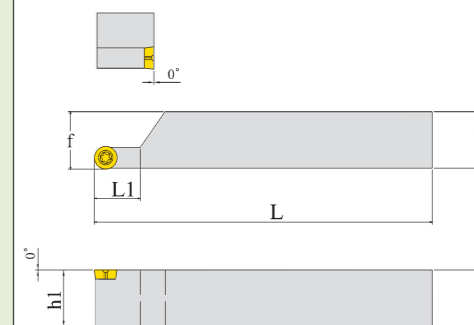

型号 Model		h	b	L	L1	h1	f	螺丝 Screw	扳手 Wrench			
SRAC(P)R/L 1616 H06	RC(P)□□0602□□	16	16	100	15	16	16	M2.5*6	T-8			
SRAC(P)R/L 2020 K06		20	20	125	20	20	20					
SRAC(P)R/L 2525 M06	RC(P)□□0803□□	25	25	150	20	25	25	M3*10	T-10			
SRAC(P)R/L 1616 H08		16	16	100	15	16	16					
SRAC(P)R/L 2020 K08		20	20	125	20	20	20					
SRAC(P)R/L 2525 M08		25	25	150	20	25	25					
SRAC(P)R/L 3232 P08	RC(P)□□1004□□	32	32	170	25	32	32	M3.5*10	T-15			
SRAC(P)R/L 1616 H10		16	16	100	15	16	16					
SRAC(P)R/L 2020 K10		20	20	125	20	20	20					
SRAC(P)R/L 2525 M10		25	25	150	20	25	25					
SRAC(P)R/L 3232 P10		32	32	170	25	32	32					
SRAC(P)R/L 4040 R10		40	40	200	32	40	40					
SRAC(P)R/L 2020 K12		RC(P)□□1204□□	20	20	125	20	20			20	M3.5*10	T-15
SRAC(P)R/L 2525 M12			25	25	150	20	25			25		
SRAC(P)R/L 3232 P12		RC(P)□□1606□□	32	32	170	25	32			32	M5*12	T-20
SRAC(P)R/L 4040 R12			40	40	200	32	40			40		
SRAC(P)R/L 2525 M16	25		25	150	20	25	25					
SRAC(P)R/L 3232 P16	32		32	170	25	32	32					
SRAC(P)R/L 4040 R16	RC(P)□□2006□□	40	40	200	32	40	40	M6*15	T-20			
SRAC(P)R/L 3232 P20		32	32	170	25	32	32					
SRAC(P)R/L 4040 R20		40	40	200	32	40	40					

刀片后角和内孔不同，请根据所使用的刀片选购，也可根据刀片后角和要求定做。订购前请咨询客服后再下单。

Blade Angle and the inner hole is different, depending on the use of the blade, please choose and buy, also can be customized according to the blade back Angle and requirements.

D

外圆刀螺钉型 Excircle blade (screw type)

D

外圆刀螺钉型 Excircle blade (screw type)

SRDC(P)N

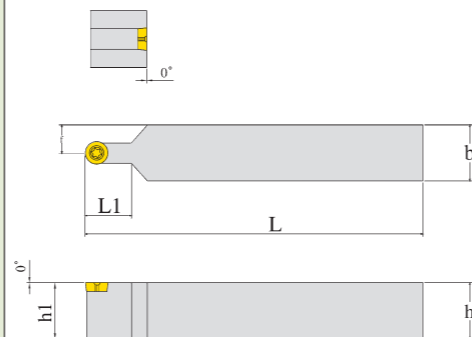

型号 Model		h	b	L	L1	h1	f	螺丝 Screw	扳手 Wrench
SRDC(P)N 1616 H06		16	16	100	15	16	16		
SRDC(P)N 2020 K06	RC(P)□□0602□□	20	20	125	15	20	20	M2.5*6	T-8
SRDC(P)N 2525 M06		25	25	150	15	25	25		
SRDC(P)N 1616 H08		16	16	100	16	16	16		
SRDC(P)N 2020 K08	RC(P)□□0803□□	20	20	125	16	20	20	M3*10	T-10
SRDC(P)N 2525 M08		25	25	150	16	25	25		
SRDC(P)N 3232 P08		32	32	170	16	32	32		
SRDC(P)N 1616 H10		16	16	100	20	16	16		
SRDC(P)N 2020 K10		20	20	125	20	20	20		
SRDC(P)N 2525 M10	RC(P)□□1004□□	25	25	150	20	25	25	M3.5*10	T-15
SRDC(P)N 3232 P10		32	32	170	20	32	32		
SRDC(P)N 4040 R10		40	40	200	20	40	40		
SRDC(P)N 2020 K12		20	20	125	28	20	20		
SRDC(P)N 2525 M12	RC(P)□□1204□□	25	25	150	28	25	25	M3.5*10	T-15
SRDC(P)N 3232 P12		32	32	170	28	32	32		
SRDC(P)N 4040 R12		40	40	200	28	40	40		
SRDC(P)N 2525 M16		25	25	150	32	25	25		
SRDC(P)N 3232 P16	RC(P)□□1606□□	32	32	170	32	32	32	M5*12	T-20
SRDC(P)N 4040 R16		40	40	200	32	40	40		
SRDC(P)N 3232 P20		32	32	170	40	32	32		
SRDC(P)N 4040 R20	RC(P)□□2006□□	40	40	200	40	40	40	M6*15	T-20

刀片后角和内孔不同，请根据所使用的刀片选购，也可根据刀片后角和要求定做。订购前请咨询客服后再下单。

Blade Angle and the inner hole is different, depending on the use of the blade, please choose and buy, also can be customized according to the blade back Angle and requirements.

SRGC(P)R/L

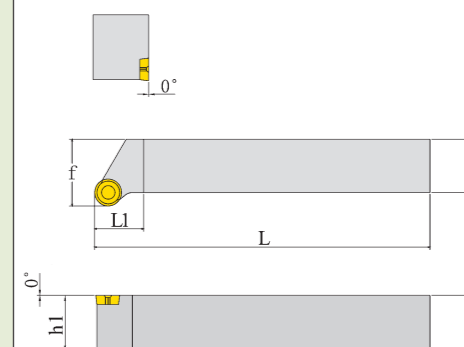

型号 Model		h	b	L	L1	h1	f	螺丝 Screw	扳手 Wrench
SRGC(P)R/L 1616 H06		16	16	100	15	16	20		
SRGC(P)R/L 2020 K06	RC(P)□□0602□□	20	20	125	15	20	25	M2.5*6	T-8
SRGC(P)R/L 2525 M06		25	25	150	15	25	32		
SRGC(P)R/L 1616 H08		16	16	100	16	16	20		
SRGC(P)R/L 2020 K08	RC(P)□□0803□□	20	20	125	16	20	25	M3*10	T-10
SRGC(P)R/L 2525 M08		25	25	150	16	25	32		
SRGC(P)R/L 3232 P08		32	32	170	16	32	40		
SRGC(P)R/L 1616 H10		16	16	100	20	16	20		
SRGC(P)R/L 2020 K10		20	20	125	20	20	25		
SRGC(P)R/L 2525 M10	RC(P)□□10T3□□	25	25	150	20	25	32	M3.5*10	T-15
SRGC(P)R/L 3232 P10		32	32	170	20	32	40		
SRGC(P)R/L 4040 R10		40	40	200	20	40	50		
SRGC(P)R/L 2020 K12		20	20	125	28	20	25		
SRGC(P)R/L 2525 M12	RC(P)□□1204□□	25	25	150	28	25	32	M3.5*10	T-15
SRGC(P)R/L 3232 P12		32	32	170	28	32	40		
SRGC(P)R/L 4040 R12		40	40	200	28	40	50		
SRGC(P)R/L 2525 M16		25	25	150	32	25	32		
SRGC(P)R/L 3232 P16	RC(P)□□1606□□	32	32	170	32	32	40	M5*12	T-20
SRGC(P)R/L 4040 R16		40	40	200	32	40	50		
SRGC(P)R/L 3232 P20		32	32	170	40	32	40		
SRGC(P)R/L 4040 R20	RC(P)□□2006□□	40	40	200	40	40	50	M6*15	T-20

刀片后角和内孔不同，请根据所使用的刀片选购，也可根据刀片后角和要求定做。订购前请咨询客服后再下单。

Blade Angle and the inner hole is different, depending on the use of the blade, please choose and buy, also can be customized according to the blade back Angle and requirements.

镗刀杆识别系统 BORING BAR IDENTIFICATION SYSTEM

P-type型号	C-type型号
D-type型号	M-type型号
C-type型号	
4 夹紧方式	

A 90°	G 91°	P 62.5°	X 100°
B 75°	H 91°	Q 45°	Y 80°
D 45°	J 93°	S 45°	Z 93°
E 60°	K 75°	V 72.5°	
F 91°	L 95°	U 95°	
6 切入角			

S **25** **R** - **M** **C** **L** **N** **R** **12**

1 材质	2 柄的直径	3 长度 (mm)	5 刀片形状	7 刀片后角	8 方向	9 切削长
C 碳化钨		H 100	C 四边形 顶角80°	C 7°	L	1 1
H 高速钢		K 125	D 四边形 顶角55°	B 5°	R	2 2
S 合金钢		M 150	K 平形四边形 顶角55°	N 0°		3 3
		N 160	R 圆形	P 11°		4 4
		Q 180	S 正方形			5 5
		R 200	T 正三角形			6 6
		S 250	V 四边形 顶角35°			7 7
		T 300	W 特殊六角形			8 8
		U 350				9 9
		V 400				
		W 450				
		Y 500				

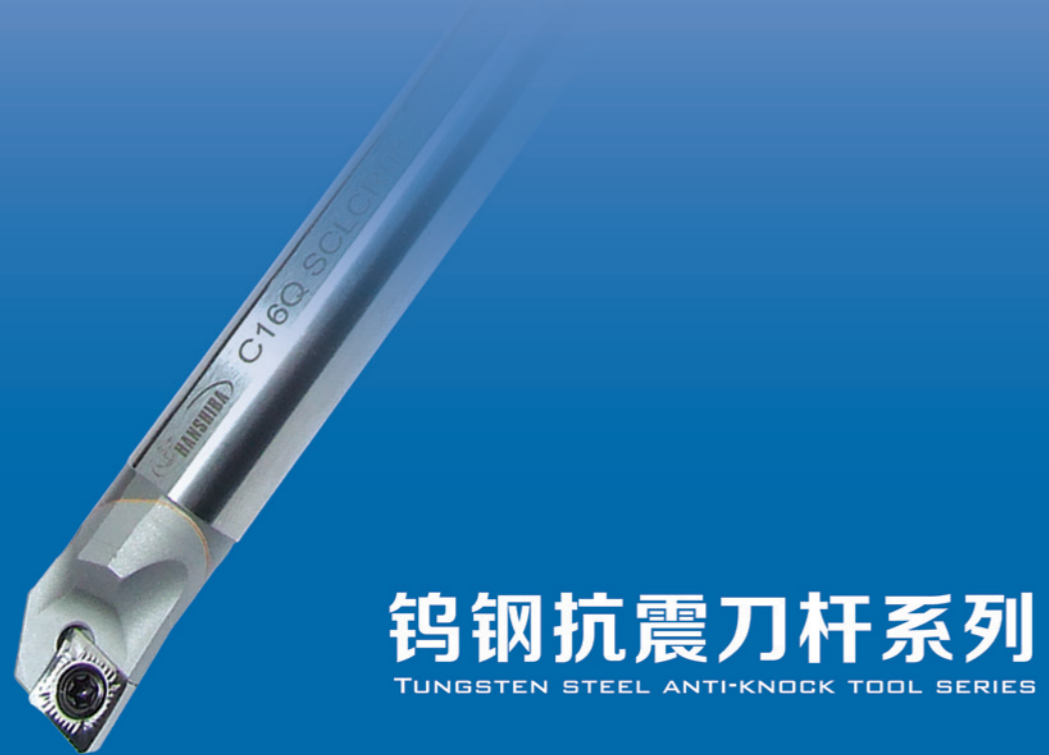

钨钢抗震刀杆系列

TUNGSTEN STEEL ANTI-KNOCK TOOL SERIES

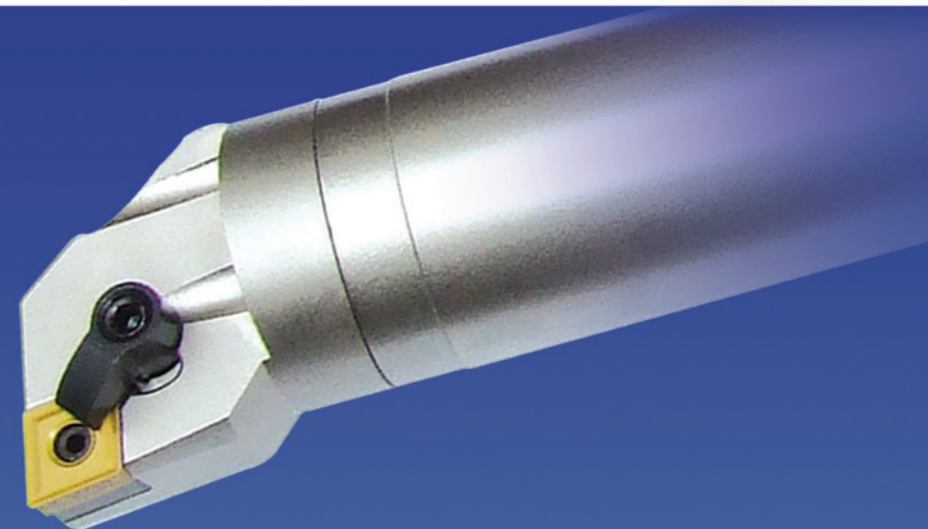

NEW!

换头防震镗刀

Head removable & anti-shock boring cutter

性能

- ▲ 防震有效深度可达 4-4.5 倍径
- ▲ 防震性能明显优越于普通合金钢刀杆。工件表面光洁度更好，尺寸更稳定，刀片耐磨性增加，降低生产成本，进而提升效益。
- ▲ 同一的刀体尺寸适应不同的工件角度及加工条件，可直接更换防震刀头，避免再次校对中心，省时省力。
- ▲ 此款刀杆，若刀头损坏，刀体可继续使用。有效降低使用成本，减少材料浪费，有益于环保。

防震系统

可换头

刀体



钨钢抗震刀杆系列 Tungsten steel anti-knock tool bar series 目录

95° 钨钢抗震镗刀杆(E1) SCLCR/L 变杆	95° 钨钢抗震镗刀杆(E1) SCLCR/L-A 变杆	95° 钨钢抗震镗刀杆(E2) SCLCR/L	95° 钨钢抗震镗刀杆(E2) SCLCR/L-A	91° 钨钢抗震镗刀杆(E3) STFCR/L
91° 钨钢抗震镗刀杆(E3) STFCR/L-A	95° 钨钢抗震镗刀杆(E4) STUCR/L	95° 钨钢抗震镗刀杆(E4) STUCR/L-A	107.5° 钨钢抗震刀杆(E5) SDQCR/L	95° 钨钢抗震镗刀杆(E5) SDUCR/L
93° 钨钢抗震镗刀杆(E6) SWUBR/L	93° 钨钢抗震镗刀杆(E6) SWUBR/L-A	内螺纹钨钢抗震刀杆(E7) CNR/L	内螺纹钨钢抗震刀杆(E7) CNR/L-A	

换头防震镗刀系列 Head removable & anti-shock boring cutter 目录

换头钨钢防震镗刀杆(F1) WGFZ	换头防震镗刀杆(F1) PTFZ	95° 换头防震镗刀头(F2) PCLNR/L	95° 换头防震镗刀头(F2) PWLNR/L	95° 换头防震镗刀头(F3) PDUNR/L
95° 换头防震镗刀头(F3) PTUNR/L	117.5° 换头防震镗刀头(F4) SVQCR/L	107.5° 换头防震镗刀头(F4) SDQCR/L	95° 换头防震镗刀头(F5) SCLCR/L	95° 换头防震镗刀头(F5) STUCR/L

SCLCR/L 变杆

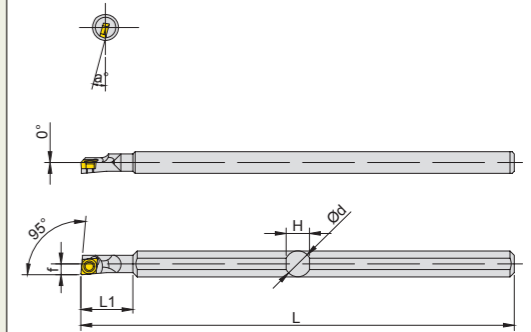
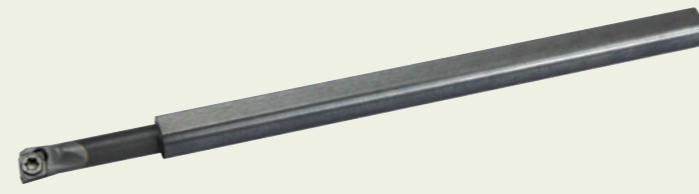

型号 Model		ØD	Ød	f	L	L1	H	a°	螺丝 Screw	扳手 Wrench
C0604H-SCLCR/L03-3	CC□□0301□□	5.5	6	2.5	100	12	5.4	15	M1.6*4	T-6
C0604H-SCLCR/L03-5	CC□□0301□□	5.5	6	2.5	100	20	5.4	15	M1.6*4	T-6
C0605H-SCLCR/L04-3	CC□□0401□□	6	6	3	100	15	5.4	15	M2*4	T-6
C0605H-SCLCR/L04-5	CC□□0401□□	6	6	3	100	25	5.4	15	M2*4	T-6

SCLCR/L-A 变杆

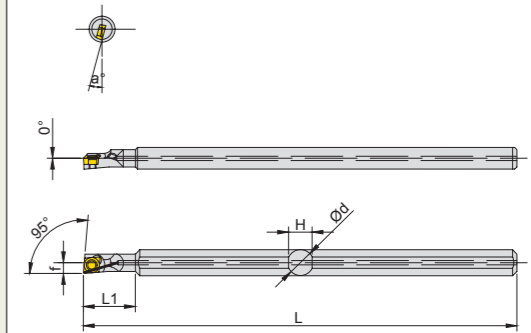
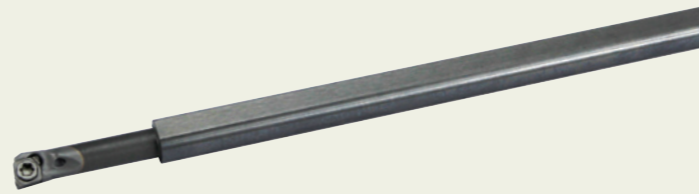

型号 Model		ØD	Ød	f	L	L1	H	a°	螺丝 Screw	扳手 Wrench
C0604H-SCLCR/L03-A-3	CC□□0301□□	5.5	6	2.5	100	12	5	15	M1.6*4	T-6
C0604H-SCLCR/L03-A-5	CC□□0301□□	5.5	6	2.5	100	20	5	15	M1.6*4	T-6
C0605H-SCLCR/L04-A-3	CC□□0401□□	6	6	3	100	15	5	15	M2*4	T-6
C0605H-SCLCR/L04-A-5	CC□□0401□□	6	6	3	100	25	4	15	M2*4	T-6

SCLCR/L

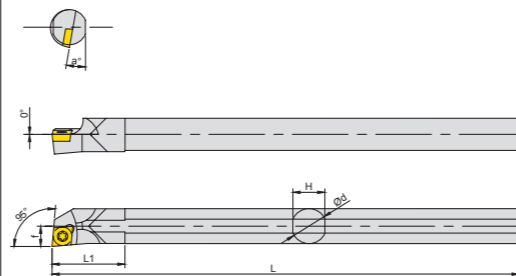

型号 Model		∅D	∅d	f	L	L1	H	a°	螺丝 Screw	扳手 Wrench
C05H-SCLCR/L04	CC□□0401□□	7	5	3	100	15	4	15	M2*4	T-6
C06H-SCLCR/L04		8	6	3.5	100	15	5	15		
C07K-SCLCR/L06	CC□□0602□□	9	7	4.5	125	20	6	13	M2.5*6	T-8
C08K-SCLCR/L06		10	8	5	125	20	7	13		
C09K-SCLCR/L06		11	9	5.5	125	22	8	12		
C10K-SCLCR/L06		12	10	6	125	22	9	12		
C12M-SCLCR/L06		14	12	7	150	25	11	10		
C12N-SCLCR/L06		14	12	7	160	25	11	10		
C12Q-SCLCR/L06	CC□□09T3□□	14	12	7	180	25	11	10	M3.5*8	T-15
C12M-SCLCR/L09		15	12	7.5	150	25	11	12		
C12N-SCLCR/L09	CC□□09T3□□	15	12	7.5	160	25	11	12	M3.5*8	T-15
C16Q-SCLCR/L09		20	16	9.5	180	28	15	10		
C20R-SCLCR/L09		25	20	12	200	33	19	8		
C20S-SCLCR/L09		25	20	12	250	33	19	8		
C25T-SCLCR/L09		31	25	14.5	300	38	24	6		
C25U-SCLCR/L09		31	25	14.5	350	38	24	6		

SCLCR/L-A

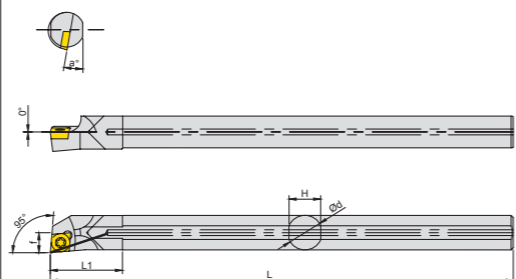

型号 Model		∅D	∅d	f	L	L1	H	a°	螺丝 Screw	扳手 Wrench
C05H-SCLCR/L04-A	CC□□0401□□	7	5	3	100	15	5	15	M2*4	T-6
C06H-SCLCR/L04-A		8	6	3.5	100	15	5	15		
C08K-SCLCR/L06-A	CC□□0602□□	10	8	5	125	20	7	13	M2.5*6	T-8
C10K-SCLCR/L06-A		13	10	6	125	22	9	12		
C12M-SCLCR/L06-A		16	12	7	150	25	11	10		
C12Q-SCLCR/L09-A		16	12	7.5	150	25	11	12		
C16Q-SCLCR/L09-A		20	16	9.5	180	28	15	10		
C16R-SCLCR/L09-A		20	16	9.5	200	28	15	10		
C20R-SCLCR/L09-A	CC□□09T3□□	25	20	12	200	33	19	8	M3.5*8	T-15
C20S-SCLCR/L09-A		25	20	12	250	33	19	8		
C25T-SCLCR/L09-A		31	25	14.5	300	38	24	6		
C25U-SCLCR/L09-A		31	25	14.5	350	38	24	6		

STFCR/L

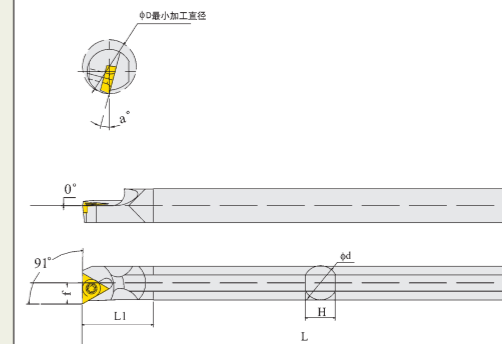

型号 Model		∅D	∅d	f	L	L1	H	a°	螺丝 Screw	扳手 Wrench
C08K-STFC(P)R/L 09	TC(P)□□0902□□	10	8	5	125	20	7	13	C:M2.2*5 P:M2.5*6	T-8
C10K-STFC(P)R/L 09		13	10	6	125	22	9	12		
C10K-STFC(P)R/L 11		16	12	7	150	22	11	10		
C12M-STFC(P)R/L 11	TC□□1102□□	16	12	7.5	150	25	11	12	C:M2.5*6 P:M3*7	T-8
C12Q-STFC(P)R/L 11		16	12	7.5	180	25	11	12		
C16Q-STFC(P)R/L 11	TP□□1103□□	20	16	9.5	180	28	15	10	M3.5*8	T-15
C16R-STFC(P)R/L 11		20	16	9.5	200	28	15	10		
C20R-STFC(P)R/L 16	TC(P)□□16T3□□	25	20	12	200	33	19	8	M3.5*8	T-15
C20S-STFC(P)R/L 16		25	20	12	250	33	19	8		

STFCR/L-A

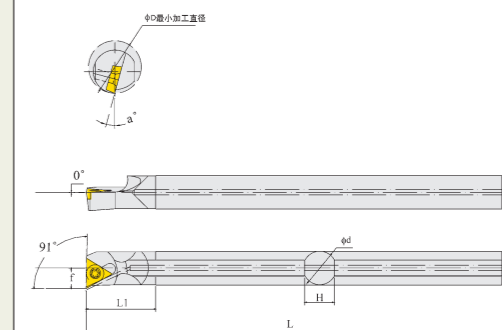

型号 Model		∅D	∅d	f	L	L1	H	a°	螺丝 Screw	扳手 Wrench
C08K-STFC(P)R/L 09-A	TC(P)□□0902□□	10	8	5	125	20	7	13	C:M2.2*5 P:M2.5*6	T-8
C10K-STFC(P)R/L 09-A		13	10	6	125	22	9	12		
C10K-STFC(P)R/L 11-A		16	12	7	150	22	11	10		
C12M-STFC(P)R/L 11-A	TC□□1102□□	16	12	7.5	150	25	11	12	C:M2.5*6 P:M3*7	T-8
C12Q-STFC(P)R/L 11-A		16	12	7.5	180	25	11	12		
C16Q-STFC(P)R/L 11-A	TP□□1103□□	20	16	9.5	180	28	15	10	M3.5*8	T-15
C16R-STFC(P)R/L 11-A		20	16	9.5	200	28	15	10		
C20R-STFC(P)R/L 16-A	TC(P)□□16T3□□	25	20	12	200	33	19	8	M3.5*8	T-15
C20S-STFC(P)R/L 16-A		25	20	12	250	33	19	8		

STUCR/L

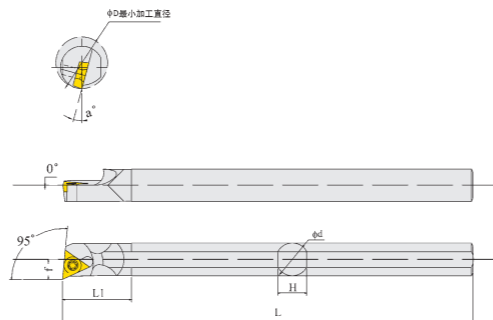

型号 Model		∅D	∅d	f	L	L1	H	a°	螺丝 Screw	扳手 Wrench
C06H-STUBR/L 06	TB□□0601□□	8	6	3.5	100	15	5	15	M2*4	T-6
C08K-STUC(P)R/L 09	TC(P)□□0902□□	10	8	5	125	20	7	13	C:M2.2*5 P:M2.5*6	T-8
C10K-STUC(P)R/L 09		13	10	6	125	22	9	12		
C10K-STUC(P)R/L 11	TC□□1102□□	16	12	7	150	22	11	10	C:M2.5*6 P:M3*7	T-8
C12M-STUC(P)R/L 11		16	12	7.5	150	25	11	12		
C16Q-STUC(P)R/L 11	TP□□1103□□	20	16	9.5	180	28	15	10	M3.5*8	T-15
C16R-STUC(P)R/L 11	TC□□16T3□□	25	20	12	200	33	19	8		
C20R-STUC(P)R/L 16	TP□□1603□□	25	20	12	250	33	19	8		

SDQCR/L

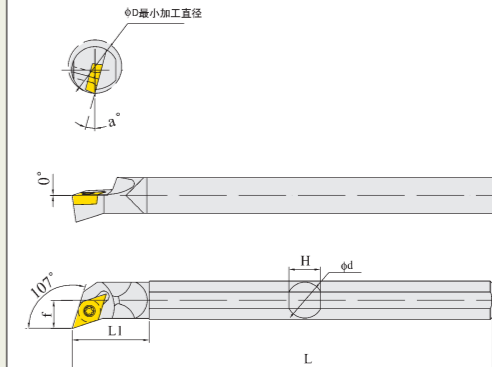

型号 Model		∅D	∅d	f	L	L1	H	a°	螺丝 Screw	扳手 Wrench
C08K-SDQCR/L07	DC□□0702□□	13	8	6	125	20	7	12	M2.5*6	T-8
C10K-SDQCR/L07		16	10	7	125	23	9	10		
C12M-SDQCR/L07		20	12	9	150	30	11	8		
C12Q-SDQCR/L07		20	12	9	180	30	11	8		
C16N-SDQCR/L07		25	16	10.5	160	30	15	6		
C16Q-SDQCR/L07		25	16	10.5	180	30	15	6		
C16N-SDQCR/L11	DC□□11T3□□	25	16	11	160	30	15	6	M3.5*8	T-15
C16Q-SDQCR/L11		25	16	11	180	30	15	6		
C16R-SDQCR/L11		25	16	11	200	30	15	6		
C20R-SDQCR/L11		28	20	13	200	39	19	6		
C20S-SDQCR/L11		28	20	13	250	39	19	6		

STUCR/L-A

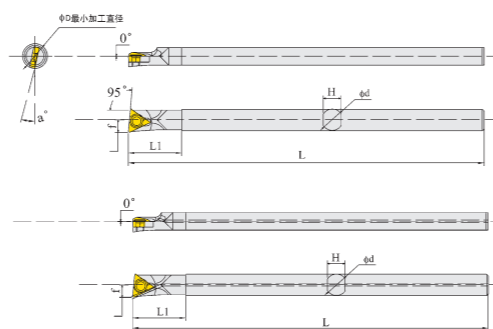

型号 Model		∅D	∅d	f	L	L1	H	a°	螺丝 Screw	扳手 Wrench
C06H-STUBR/L 06-A	TB□□0601□□	8	6	3.5	100	15	5	15	M2*4	T-6
C08K-STUC(P)R/L 09-A	TC(P)□□0902□□	10	8	5	125	20	7	13	C:M2.2*5 P:M2.5*6	T-8
C10K-STUC(P)R/L 09-A		13	10	6	125	22	9	12		
C10K-STUC(P)R/L 11-A	TC□□1102□□	16	12	7	150	22	11	10	C:M2.5*6 P:M3*7	T-8
C12M-STUC(P)R/L 11-A		16	12	7.5	150	25	11	12		
C16Q-STUC(P)R/L 11-A	TP□□1103□□	20	16	9.5	180	28	15	10	M3.5*8	T-15
C16R-STUC(P)R/L 11-A	TC□□16T3□□	25	20	12	200	33	19	8		
C20R-STUC(P)R/L 16-A	TP□□1603□□	25	20	12	250	33	19	8		

SDUCR/L

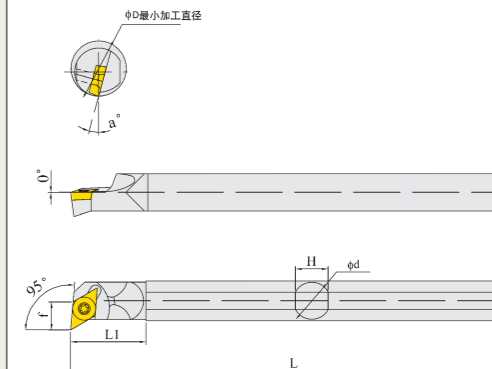

型号 Model		∅D	∅d	f	L	L1	H	a°	螺丝 Screw	扳手 Wrench
C08K-SDUCR/L07	DC□□0702□□	13	10	7	125	25	9	12	M2.5*6	T-8
C10K-SDUCR/L07		15	10	8	125	25	9	10		
C12M-SDUCR/L07		17	12	9	150	28	11	8		
C12Q-SDUCR/L07		17	12	9	180	28	11	8		
C16N-SDUCR/L07		22	16	11	160	30	15	6		
C16Q-SDUCR/L07		22	16	11	180	30	15	6		
C16N-SDUCR/L11	DC□□11T3□□	23	20	11.5	160	35	15	8	M3.5*8	T-15
C16Q-SDUCR/L11		23	20	11.5	180	35	15	8		
C16R-SDUCR/L11		23	20	11.5	200	35	15	8		
C20R-SDUCR/L11		25	20	13	200	40	19	6		
C20S-SDUCR/L11		25	20	13	250	40	19	6		
C25T-SDUCR/L11		32	25	16	300	45	24	4		

SWUBR/L

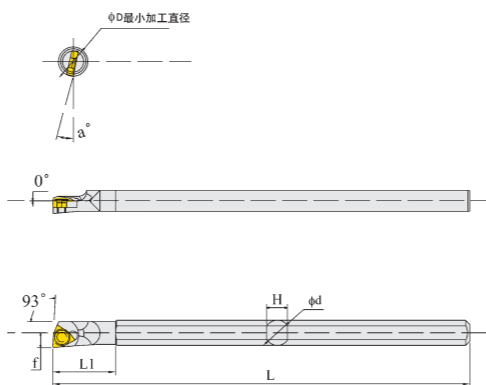
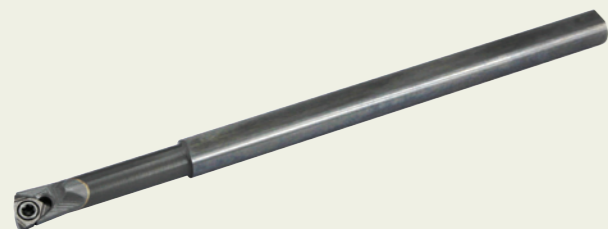

型号 Model		ϕD	ϕd	f	L	L1	H	a°	螺丝 Screw 	扳手 Wrench
C06H-SWUBR/L 03	WB□□0301□□	8	6	3.5	100	15	5	15	M2*4	T-6

SWUBR/L-A

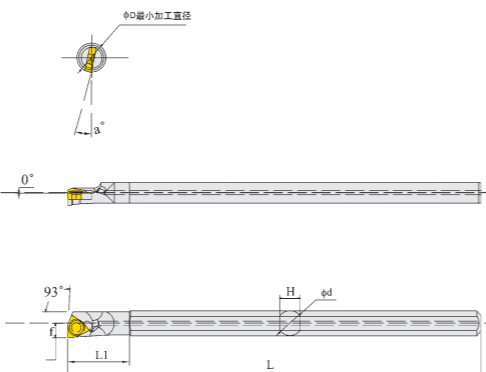

型号 Model		ϕD	ϕd	f	L	L1	H	a°	螺丝 Screw 	扳手 Wrench
C06H-SWUBR/L 03-A-3	WB□□0301□□	6	6	3	100	15	5	15	M2*4	T-6
C06H-SWUBR/L 03-A-5		6	6	3	100	25	5	15		
C06H-SWUBR/L 03-A		8	6	3.5	100	15	5	15		

CNR/L

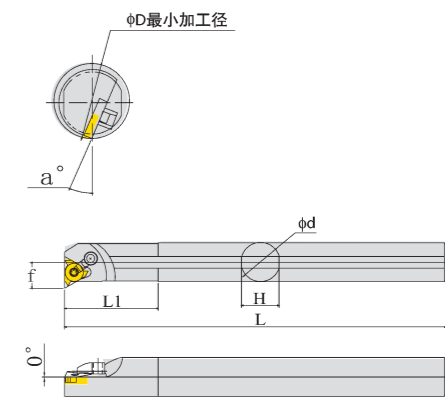

型号 Model		ϕD	ϕd	f	L	L1	H	a°	螺丝 Screw 	扳手 Wrench
CNR/L 0008K08	11NR/L	11	8	6.2	125	22	7	17	M2.2*5	T8
CNR/L 0010K11		13	12	7.2	125	22	9	15	M2.5*6	T8
CNR/L 0012M11		15	13	7.8	150	32	11	17		
CNR/L 0016N16	16NR/L	19	16	11.7	160	36	15	15	M3.5*10	T15
CNR/L 0016Q16		19	16	11.7	180	36	15	15		
CNR/L 0020Q16		24	20	13.7	180	40	19	21		
CNR/L 0020R16		24	20	13.7	200	40	19	21		

CNR/L-A

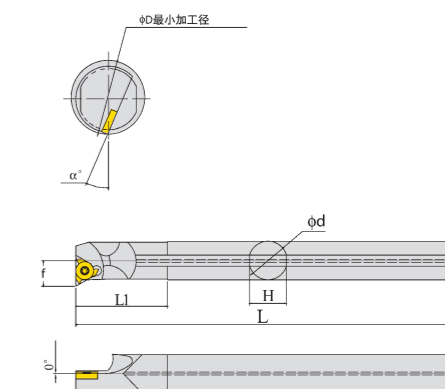

型号 Model		ϕD	ϕd	f	L	L1	H	a°	螺丝 Screw 	扳手 Wrench
CNR/L 0008K08-A	11NR/L	11	8	6.2	125	22	7	17	M2.2*5	T8
CNR/L 0010K11-A		13	12	7.2	125	22	9	15	M2.5*6	T8
CNR/L 0012M11-A		15	13	7.8	150	32	11	17		
CNR/L 0016N16-A	16NR/L	19	16	11.7	160	36	15	15	M3.5*10	T15
CNR/L 0016Q16-A		19	16	11.7	180	36	15	15		
CNR/L 0020Q16-A		24	20	13.7	180	40	19	21		
CNR/L 0020R16-A		24	20	13.7	200	40	19	21		

WGfZ

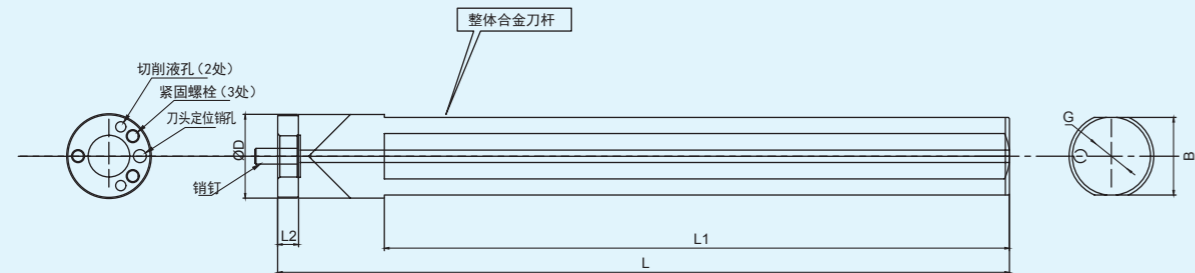

型号 Model	ØD	B	L	L1	L2	G	螺丝 Screw	扳手 Wrench
WGfZ-3232-310	32	30	310	280	8	ZG1/4	0520 0530	L4.0
WGfZ-4040-360	40	38	360	330	8			
WGfZ-5050-460	50	48	460	430	8			

PCLNR/L

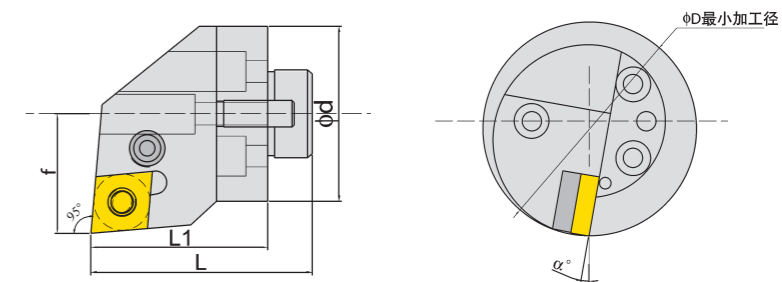
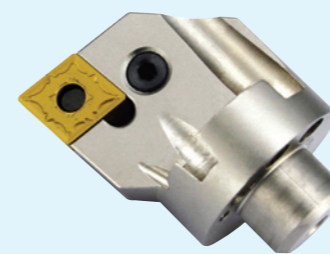

型号 Model	配件	ØD	Ød	L	L1	f	α°	杠杆GGX Level GGX	螺丝NLJ-P Screw NLJ-P	垫片CN-P Spacer CN-P	垫销DX Shim DX	扳手 Wrench
TH32-PCLNR/L 12	CN□□1204□□	40	32	50	40	22.5	10	GGX0514	NLJ0820-P	CN1203-P	DX0606	L3.0
TH40-PCLNR/L 12		50	40	50	40	27	10					
TH50-PCLNR/L 12		60	50	50	40	32	10					

PTfZ

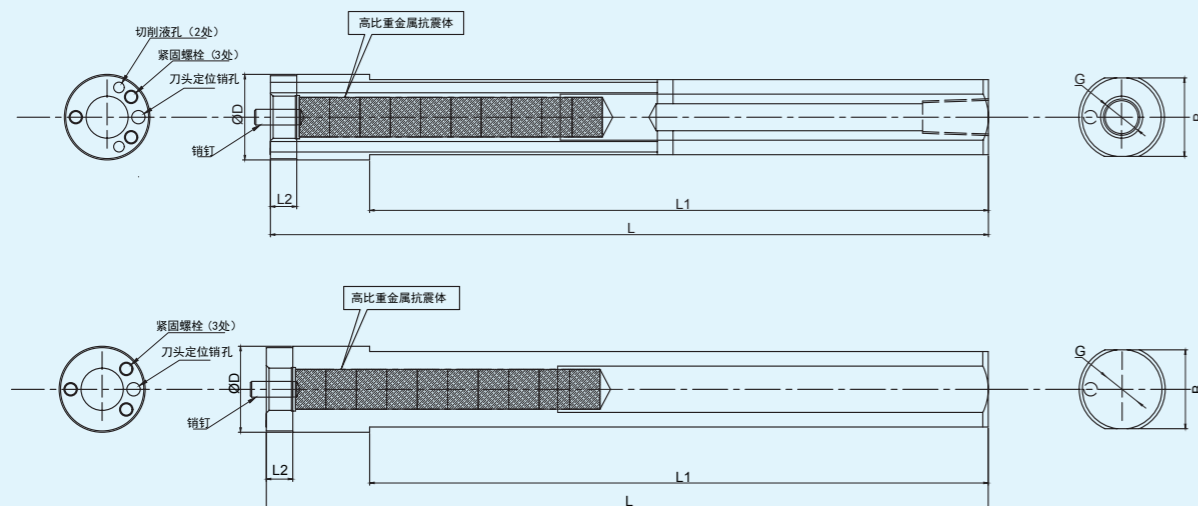

型号 Model	ØD	B	L	L1	L2	G	螺丝 Screw	扳手 Wrench
PTfZ 3232-200-A	32	29	200	170	10	ZG1/4	0520 0530	L4.0
PTfZ 3232-310-A	32	29	310	280	10			
PTfZ 4040-200-A	40	36	200	170	10			
PTfZ 4040-360-A	40	36	360	330	10			
PTfZ 5050-460-A	50	46	460	430	10			
PTfZ 3232-160	32	29	160	130	10	-	0520 0530	L4.0
PTfZ 3232-200	32	29	200	170	10			
PTfZ 3232-250	32	29	250	220	10			
PTfZ 3232-310	32	29	310	280	10			
PTfZ 4040-160	40	36	160	130	10			
PTfZ 4040-200	40	36	200	170	10			
PTfZ 4040-250	40	36	250	220	10			
PTfZ 4040-310	40	36	310	280	10			
PTfZ 5050-250	50	46	250	220	10			
PTfZ 5050-310	50	46	310	280	10			
PTfZ 5050-360	50	46	360	330	10	0620 0630	L5.0	

PWLNR/L

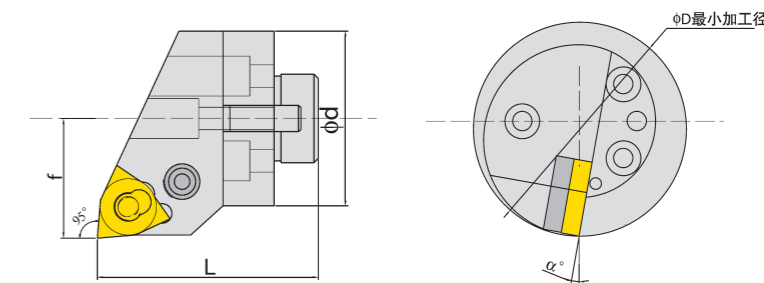

型号 Model	配件	ØD	Ød	L	L1	f	α°	杠杆GGX Level GGX	螺丝NLJ-P Screw NLJ-P	垫片WN-P Spacer WN-P	垫销DX Shim DX	扳手 Wrench
TH32-PWLNR/L 08	WN□□0804□□	40	32	50	40	22.5	10	GGX0514	NLJ0820-P	WN0803-P	DX0606	L3.0
TH40-PWLNR/L 08		50	40	50	40	27	10					
TH50-PWLNR/L 08		60	50	50	40	32	10					

F

钨钢抗震系列 Tungsten Steellant-knock Tool Bar Series

F

钨钢抗震系列 Tungsten Steellant-knock Tool Bar Series

PDUNR/L

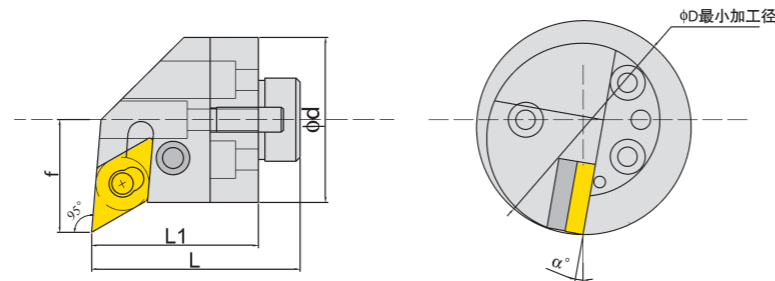
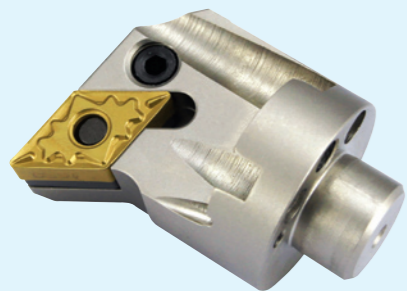

型号 Model	刀片 Insert	ϕD	ϕd	L	L1	f	a°	杠杆GGX Level GGX	螺丝NLJ-P Screw NLJ-P	垫片DN-P Spacer DN-P	垫销DX Shim DX	扳手 Wrench
TH32-PDUNR/L 15		40	32	50	40	22.5	10					
TH40-PDUNR/L 15	DN□□1504□□	50	40	50	40	27	10	GGX0514D	NLJ0821-P	DN1503-P	DX0606	L3.0
TH50-PDUNR/L 15		60	50	50	40	32	10					

SVQCR/L

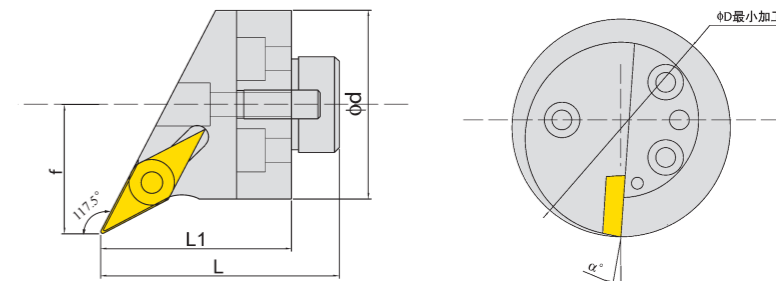
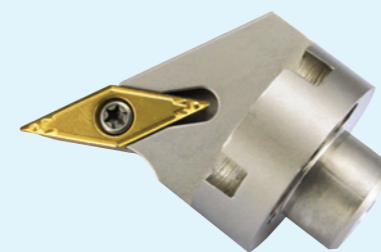

型号 Model	刀片 Insert	ϕD	ϕd	L	L1	f	a°	螺丝 Screw	扳手 Wrench
TH32-SVQCR/L 16		40	32	50	40	22.5	4		
TH40-SVQCR/L 16	VC□□1604□□	50	40	50	40	27	4	M3.5*8	T15
TH50-SVQCR/L 16		60	50	50	40	32	4		

PTUNR/L

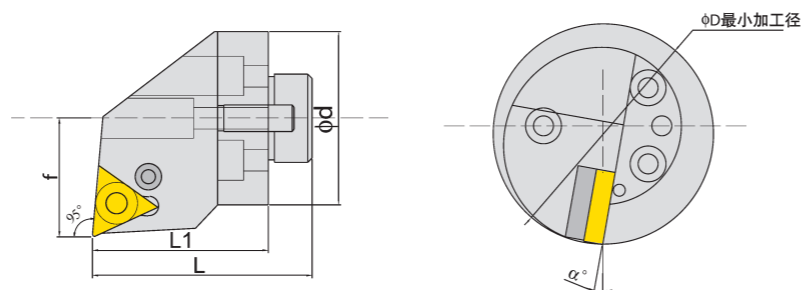

型号 Model	刀片 Insert	ϕD	ϕd	L	L1	f	a°	杠杆GGX Level GGX	螺丝NLJ-P Screw NLJ-P	垫片TN-P Spacer TN-P	垫销DX Shim DX	扳手 Wrench
TH32-PTUNR/L 16		40	32	50	40	22.5	10					
TH40-PTUNR/L 16	TN□□1604□□	50	40	50	40	27	10	GGX0310	NLJ0618-P	TN1603-P	DX0505	L3.0
TH50-PTUNR/L 16		60	50	50	40	32	10					

SDQCR/L

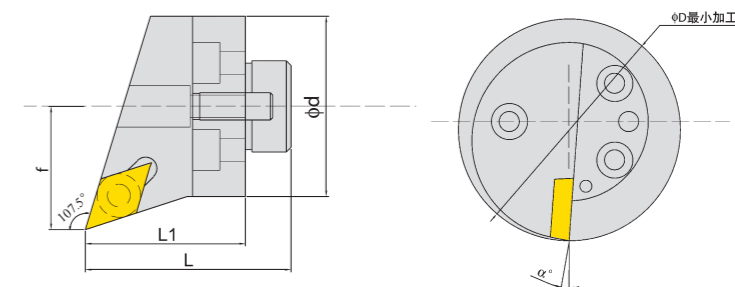
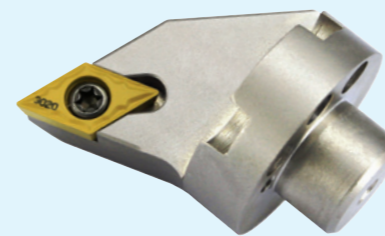

型号 Model	刀片 Insert	ϕD	ϕd	L	L1	f	a°	螺丝 Screw	扳手 Wrench
TH32-SDQCR/L 11		40	32	45	35	22.5	4		
TH40-SDQCR/L 11	DC□□11T3□□	50	40	45	35	27	4	M3.5*8	T15
TH50-SDQCR/L 11		60	50	50	40	32	4		

SCLCR/L

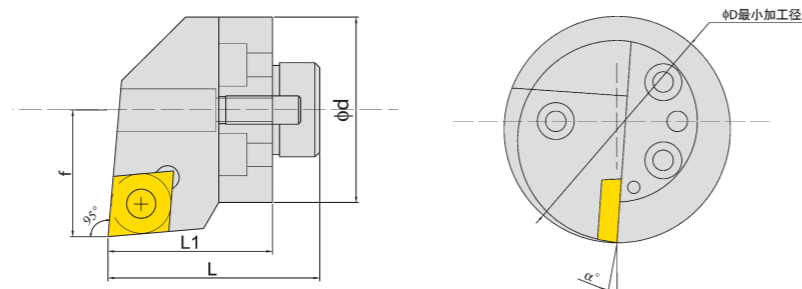
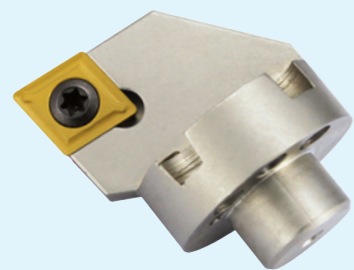

型号 Model		ϕD	ϕd	L	L1	f	α°	螺丝 Screw	扳手 Wrench
TH32-SCLCR/L 12	CC□□1204□□	40	32	45	35	22.5	4	M5*12	T20
TH40-SCLCR/L 12		50	40	45	35	27	4		
TH50-SCLCR/L 12		60	50	50	40	32	4		

STUCR/L

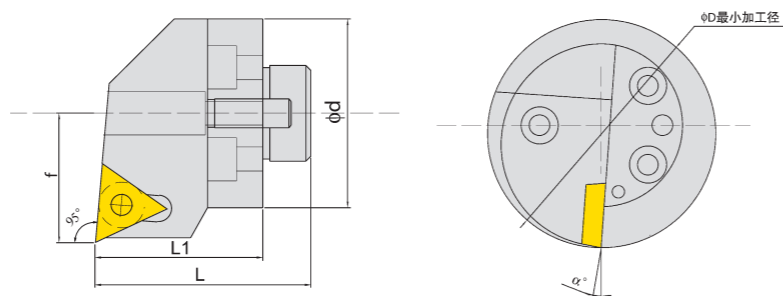
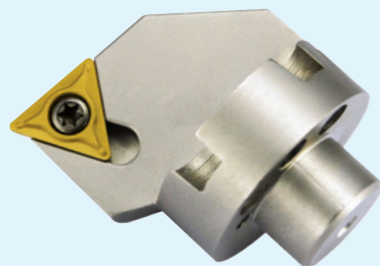

型号 Model		ϕD	ϕd	L	L1	f	α°	螺丝 Screw	扳手 Wrench
TH32-STUCR/L 16	TC□□16T3□□	40	32	45	35	22.5	4	M3.5*8	T15
TH40-STUCR/L 16		50	40	45	35	27	4		
TH50-STUCR/L 16		60	50	50	40	32	4		

压板、螺钉型镗刀 >>

Pressure plate, screw-type boring knife

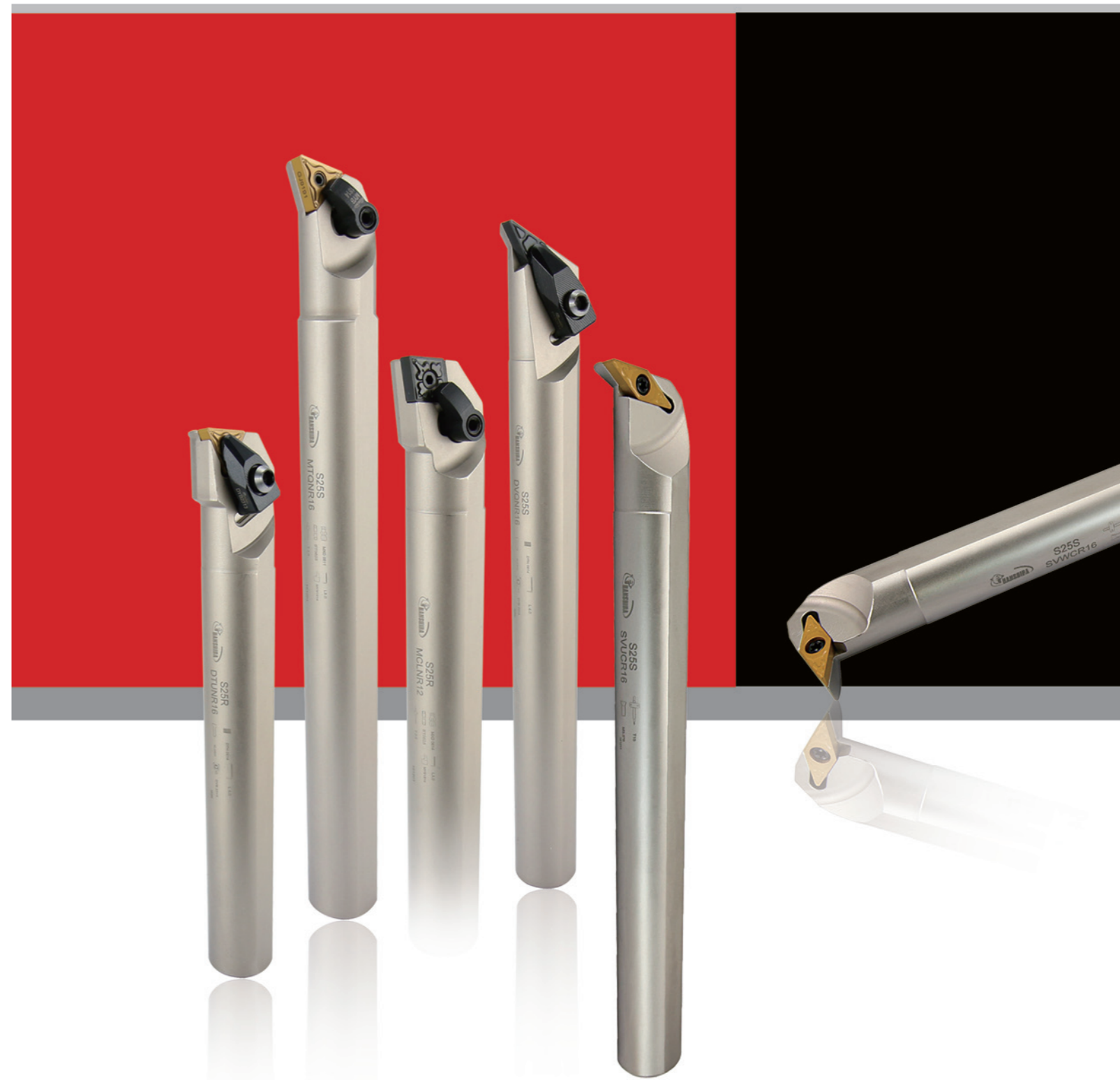

压板型镗刀系列 PLATEN TYPE BORING CUTTER

目录

95° 内径镗刀(G1) MCLNR/L	95° 内径镗刀(G1) DCLNR/L	95° 内径镗刀(G2) PCLNR/L	75° 内径镗刀(G2) MCKNR/L	50° 内径镗刀(G3) MCWNR/L
75° 内径镗刀(G3) MSKNR/L	93° 内径镗刀(G4) MTJNR/L	105° 内径镗刀(G4) MTQNR/L	91° 内径镗刀(G5) MTFNR/L	60° 内径镗刀(G5) MTWNR/L
95° 内径镗刀(G6) MTUNR/L	95° 内径镗刀(G6) DTUNR/L	95° 内径镗刀(G7) PTUNR/L	95° 内径镗刀(G7) PTUNR/L-A	95° 内径镗刀(G8) DDUNR/L
107.5° 内径镗刀(G8) DDQNR/L	95° 内径镗刀(G9) DDZNR/L	95° 内径镗刀(G9) PDUNR/L	95° 内径镗刀(G10) MWLNR/L	95° 内径镗刀(G10) DWLNR/L
95° 内径镗刀(G11) PWLNR/L	95° 内径镗刀(G11) PWLNR/L-A	95° 内径镗刀(G12) PWLNR/L	117.5° 内径镗刀(G13) DVQNR/L	95° 内径镗刀(G13) DVUNR/L
139° 内径镗刀(G14) DVXNR/L	72.5° 内径镗刀(G14) DVWNR/L			

MCLNR/L

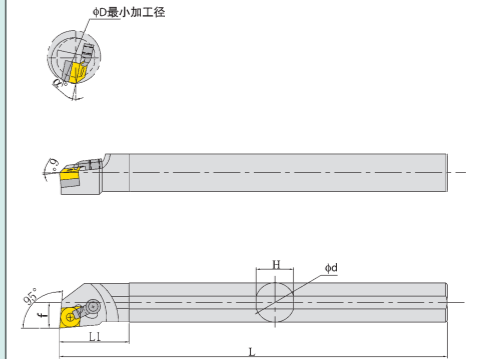
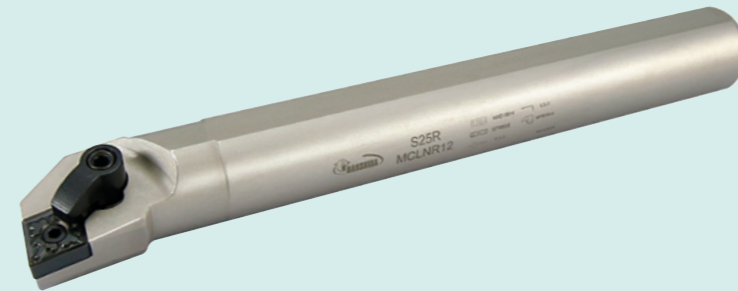

型号 Model		ØD	Ød	L	L1	H	f	a°	垫片CN Spacer CN	销钉MXD Pin MXD	压板MYB Pressing plate MYB	双头螺丝ST Double-headed Screw ST	扳手 Wrench
S20Q-MCLNR/L 12	CN□□1204□□	27	20	180	20	18	13	15	⊗	MXD0614	MYB1811	ST0620	L2.5 L3.0
S20R-MCLNR/L 12		27	20	200	25	18	13	15					
S25R-MCLNR/L 12		32	25	200	25	23	16.5	12	CN1204	MXD0617	MYB1814	ST0625	
S25S-MCLNR/L 12		32	25	250	25	23	16.5	12					
S32S-MCLNR/L 12		40	32	250	32	29	22.5	17					
S32T-MCLNR/L 12		40	32	300	32	29	22.5	17					
S40T-MCLNR/L 12		50	40	300	40	37	26	15					
S40U-MCLNR/L 12		50	40	350	40	37	26	15					

DCLNR/L

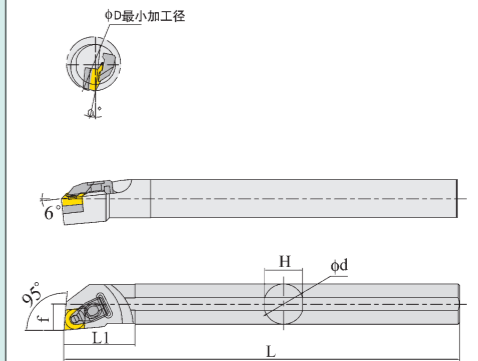
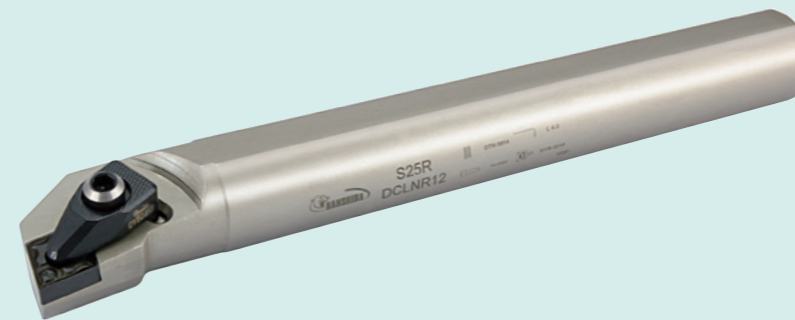

型号 Model		ØD	Ød	H	L	L1	f	a°	刀垫CN Knife pad CN	销钉DXD Pin DXD	压板DYB Pressing plate DYB	固定螺钉NLJ Fixed screw NLJ	弹簧TH Spring TH	扳手 Wrench
S20R-DCLNR/L 12	CN□□1204□□	27	20	18	200	25	13	15	⊗	⊗	DYB2413	NLJ0525	TH0814	L4.0
S25S-DCLNR/L 12		32	25	23	250	25	16.5	12						
S32T-DCLNR/L 12		40	32	30	300	32	22.5	17	CN1204	DXD0614				
S40U-DCLNR/L 12		50	40	37	350	40	26	15						

G

压板型镗刀系列 Platen type boring cutter

PCLNR/L

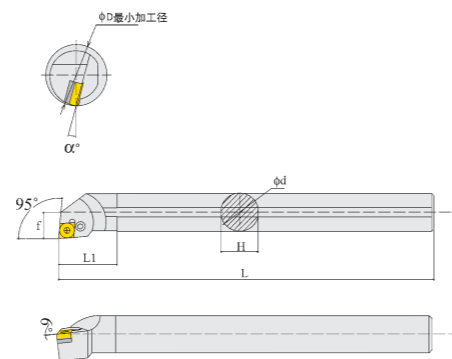

型号 Model		ϕD	ϕd	H	L	L1	f	a°	杠杆GGX Level GGX	螺丝NLJ-P Screw NLJ-P	垫片CN-P Spacer CN-P	垫销DX Shim DX	扳手 Wrench
S20R-PCLNR/L 09	CN□□0903□□	25	20	18	200	25	13	15	GGX0310A	NLJ0615-P	⊗	⊗	L3.0
S25S-PCLNR/L 12	CN□□1204□□	32	25	23	250	25	17	12	GGX0514A	NLJ0816-P	⊗	⊗	
S32T-PCLNR/L 12		40	32	29	300	32	22	17	GGX0514	NLJ0820-P	CN1203-P	DX0606	
S40T-PCLNR/L 12		50	40	37	300	40	27	15					

MCWNR/L

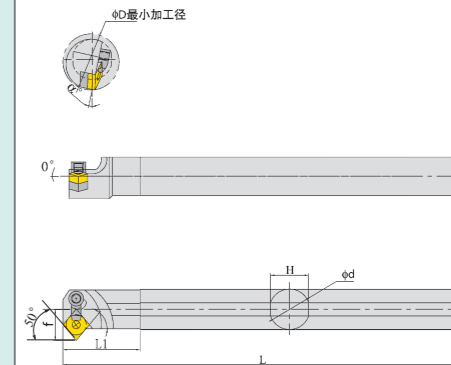
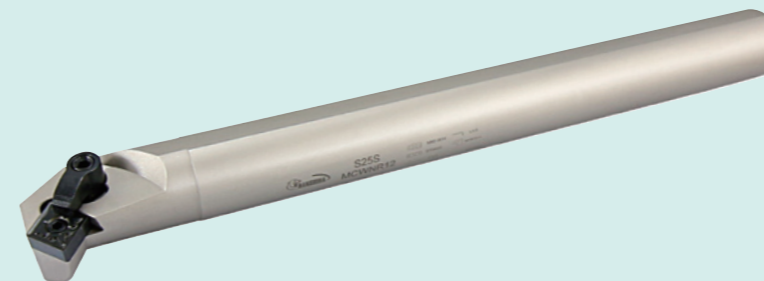

型号 Model		ϕD	ϕd	L	L1	H	f	a°	垫片CN Spacer CN	销钉MXD Pin MXD	压板MYB Pressing plate MYB	双头螺丝ST Double-headed Screw ST	扳手 Wrench
S20R-MCWNR/L 12	CN□□1204□□	30	20	200	25	18	17	15	⊗	MXD0614	MYB1811	ST0620	L2.5
S25S-MCWNR/L 12		35	25	250	25	23	19.5	12	CN1204	MXD0617	MYB1814	ST0625	L3.0
S32T-MCWNR/L 12		42	32	300	32	29	23	17					

MCKNR/L

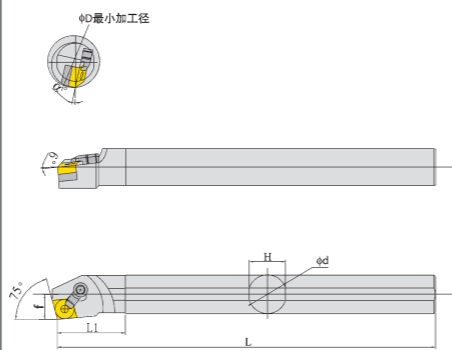

型号 Model		ϕD	ϕd	L	L1	H	f	a°	垫片CN Spacer CN	销钉MXD Pin MXD	压板MYB Pressing plate MYB	双头螺丝ST Double-headed Screw ST	扳手 Wrench
S20Q-MCKNR/L 12	CN□□1204□□	27	20	180	20	18	14	15	⊗	MXD0614	MYB1811	ST0620	L2.5 L3.0
S20R-MCKNR/L 12		27	20	200	25	18	14	15					
S25R-MCKNR/L 12		32	25	200	25	23	16	12					
S25S-MCKNR/L 12		32	25	250	25	23	16	12	CN1204	MXD0617	MYB1814	ST0625	
S32S-MCKNR/L 12		40	32	250	32	29	22	17					
S32T-MCKNR/L 12		40	32	300	32	29	22	17					

MSKNR/L

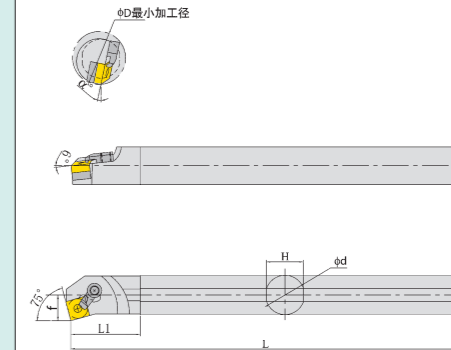
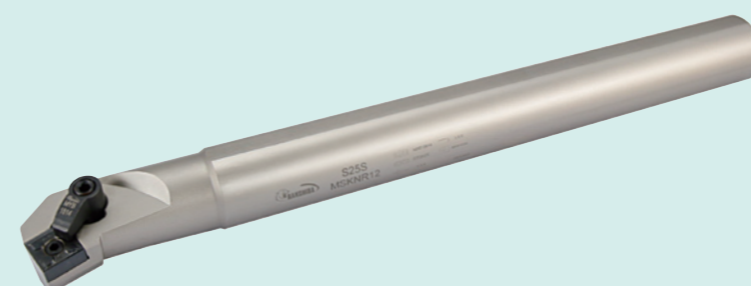

型号 Model		ϕD	ϕd	L	L1	H	f	a°	垫片SN Spacer SN	销钉MXD Pin MXD	压板MYB Pressing plate MYB	双头螺丝ST Double-headed Screw ST	扳手 Wrench
S20R-MSKNR/L 12	SN□□1204□□	27	20	200	25	18	13	15	⊗	MXD0614	MYB1811	ST0620	L2.5
S25S-MSKNR/L 12		32	25	250	30	23	17	12					
S32T-MSKNR/L 12		40	32	300	35	29	22	17					

MTJNR/L

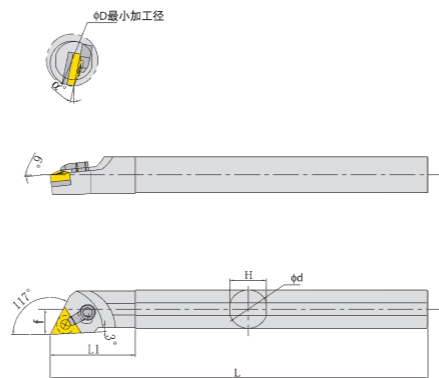

型号 Model		ØD	Ød	L	L1	H	f	a°	垫片TN Spacer TN	销钉MXD Pin MXD	压板MYB Pressing plate MYB	双头螺丝ST Double-headed Screw ST	扳手 Wrench
S20Q-MTJNR/L 16	TN□□1604□□	27	20	180	30	18	13	15	⊗	MXD0511	MYB1811	ST0620	L2.0 L3.0
S20R-MTJNR/L 16		27	20	200	30	18	13	15					
S25R-MTJNR/L 16		32	25	200	30	23	16	12					
S25S-MTJNR/L 16		32	25	250	30	23	16	12					
S32S-MTJNR/L 16		41	32	250	32	29	22.5	17					
S32T-MTJNR/L 16		41	32	300	32	29	22.5	17					
									TN1603	MXD0513			

MTFNR/L

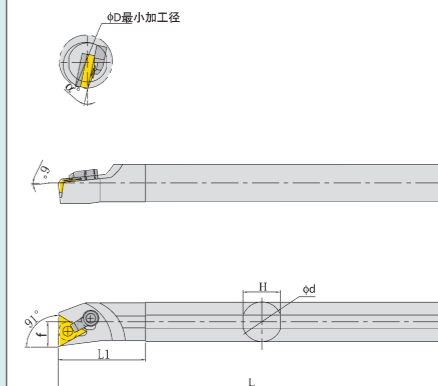

型号 Model		ØD	Ød	L	L1	H	f	a°	垫片TN Spacer TN	销钉MXD Pin MXD	压板MYB Pressing plate MYB	双头螺丝ST Double-headed Screw ST	扳手 Wrench
S16Q-MTFNR/L 16	TN□□1604□□	20	16	180	25	15	11	15	⊗	MXD0511	MYB1811	ST0620	L2.0 L3.0
S20Q-MTFNR/L 16		27	20	180	25	18	13	15					
S20R-MTFNR/L 16		27	20	200	25	18	13	15					
S25R-MTFNR/L 16		32	25	200	25	23	16.5	12					
S25S-MTFNR/L 16		32	25	250	25	23	16.5	12					
S32S-MTFNR/L 16		41	32	250	32	29	22.5	17					
S32T-MTFNR/L 16	41	32	300	32	29	22.5	17	TN1603	MXD0513				

MTQNR/L

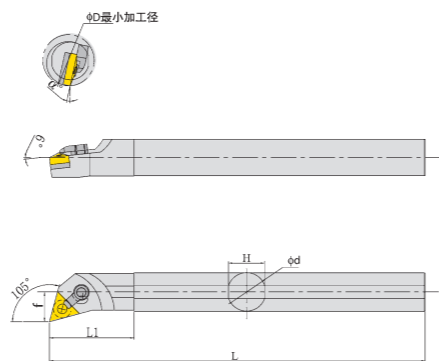

型号 Model		ØD	Ød	L	L1	H	f	a°	垫片TN Spacer TN	销钉MXD Pin MXD	压板MYB Pressing plate MYB	双头螺丝ST Double-headed Screw ST	扳手 Wrench
S20R-MTQNR/L 16	TN□□1604□□	27	20	200	25	18	12.5	15	⊗	MXD0511	MYB1811	ST0620	L2.0 L3.0
S25S-MTQNR/L 16		32	25	250	25	23	16	12					
S32T-MTQNR/L 16		41	32	300	32	29	22.5	17					

MTWNR/L

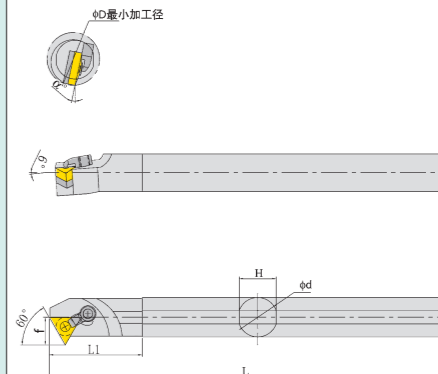

型号 Model		ØD	Ød	L	L1	H	f	a°	垫片TN Spacer TN	销钉MXD Pin MXD	压板MYB Pressing plate MYB	双头螺丝ST Double-headed Screw ST	扳手 Wrench
S20R-MTWNR/L 16	TN□□1604□□	27	20	200	25	18	14	15	⊗	MXD0511	MYB1811	ST0620	L2.0 L3.0
S25S-MTWNR/L 16		32	25	250	25	23	16	12					
S32T-MTWNR/L 16		41	32	300	32	29	20	17					

MTUNR/L

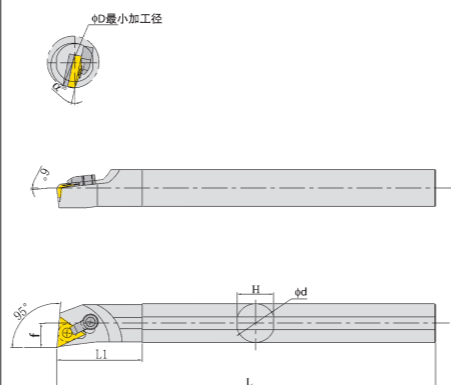

型号 Model		∅D	∅d	L	L1	H	f	a°	垫片TN Spacer TN	销钉MXD Pin MXD	压板MYB Pressing plate MYB	双头螺丝ST Double headed Screw ST	扳手 Wrench
S16Q-MTUNR/L 16	TN□□1604□□	21	16	180	25	15	11	15	⊗	MXD0511	MYB1811	ST0617	L2.0 L3.0
S20Q-MTUNR/L 16		27	20	180	25	18	13	15				ST0620	
S20R-MTUNR/L 16		27	20	200	25	18	13	15					
S25R-MTUNR/L 16		32	25	200	30	23	16.5	12			MYB1814	ST0625	
S25S-MTUNR/L 16		32	25	250	30	23	16.5	12					
S32S-MTUNR/L 16		41	32	250	35	29	22.5	17					
S32T-MTUNR/L 16		41	32	300	35	29	22.5	17			TN1603	MXD0513	

PTUNR/L

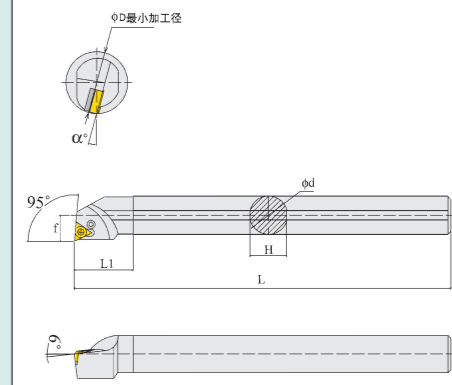

型号 Model		∅D	∅d	H	L	L1	f	a°	杠杆GGX Level GGX	螺丝NLJ-P Screw NLJ-P	垫片TN-P Spacer TN-P	垫销DX Shim DX	扳手 Wrench
S20R-PTUNR/L 16	TN□□1604□□	25	20	18	200	30	13	15	GGX0310A	NLJ0615-P	⊗	⊗	L2.5
S25S-PTUNR/L 16		32	25	23	250	35	17	12					
S32T-PTUNR/L 16		44	32	30	300	40	22	17					
S40U-PTUNR/L 16		54	40	37	350	45	27	15					

DTUNR/L

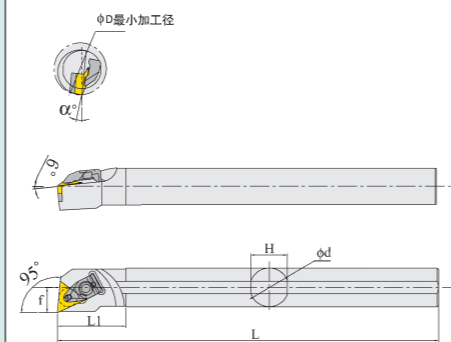

型号 Model		∅D	∅d	H	L	L1	f	a°	刀垫TN Knife pad TN	销钉DXD Pin DXD	压板DYB Pressing plate DYB	固定螺钉NLJ Fixed screw NLJ	弹簧TH Spring TH	扳手 Wrench
S20R-DTUNR/L 16	TN□□1604□□	27	20	18	200	30	13	15	⊗	⊗	DYB2513	NLJ0525	TH0814	L4.0
S25S-DTUNR/L 16		32	25	23	250	35	16.5	12						
S32T-DTUNR/L 16		42	32	29	300	40	22.5	17						

PTUNR/L-A 内冷款 **新品**

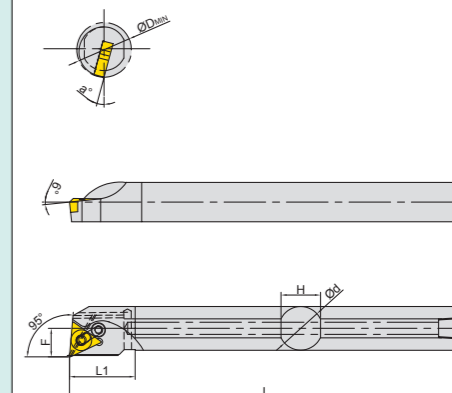

型号 Model		∅D	∅d	H	L	L1	f	a°	杠杆GGX Level GGX	螺丝NLJ-P Screw NLJ-P	垫片TN-P Spacer TN-P	垫销DX Shim DX	弹簧TH Spring TH	扳手 Wrench
S20Q-PTUNR/L16-A	TN□□1604□□	25	20	18	180	30	13	15	GGX0313A	NLJ0607-P	⊗	⊗	TH0405	L2.5
S25R-PTUNR/L16-A		32	25	23	200	35	17	12						
S32S-PTUNR/L16-A		44	32	29	250	40	22	17						
S40T-PTUNR/L16-A		54	40	37	300	45	27	15						

DDUNR/L

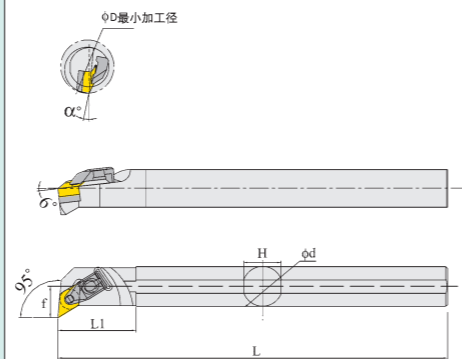
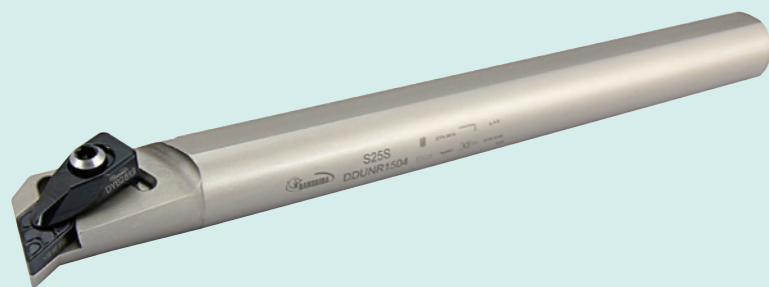

型号 Model		ØD	Ød	L	L1	H	f	a°	刀垫DN Knife pad DN	销钉DXD Pin DXD	压板DYB Pressing plate DYB	固定螺钉NLJ Fixed screw NLJ	弹簧TH Spring TH	扳手 Wrench
S25S-DDUNR/L 1504	DN□□1504□□	32	25	250	25	23	17	12	⊗	⊗				
S32T-DDUNR/L 1504		42	32	300	32	29	22.5	17	DN1504					
S40U-DDUNR/L 1504		50	40	350	40	37	26	15		DXD0614	DYB2813	NLJ0525	TH0814	L4.0
S32T-DDUNR/L 1506	DN□□1506□□	42	32	300	32	29	22.5	17	DN1504					
S40U-DDUNR/L 1506		50	40	350	40	37	26	15	DN1504					

DDZNR/L

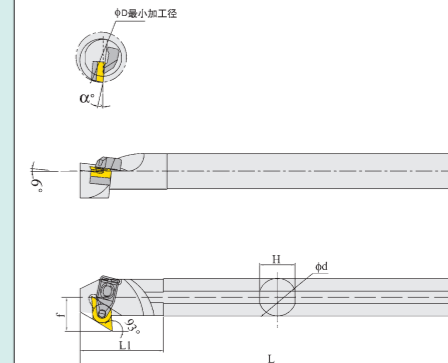

型号 Model		ØD	Ød	L	L1	H	f	a°	刀垫DN Knife pad DN	销钉DXD Pin DXD	压板DYB Pressing plate DYB	固定螺钉NLJ Fixed screw NLJ	弹簧TH Spring TH	扳手 Wrench
S32T-DDZNR/L 1504	DN□□1504□□	40	32	300	32	29	22	17	DN1504					
S40U-DDZNR/L 1504		50	40	350	40	37	27	15		DXD0614	DYB2813	NLJ0525	TH0814	L4.0
S32T-DDZNR/L 1506	DN□□1506□□	40	32	300	32	29	22.5	17	DN1504					
S40U-DDZNR/L 1506		50	40	350	40	37	27	15	DN1504					

此款刀具无现货，需要请订货。

DDQNR/L

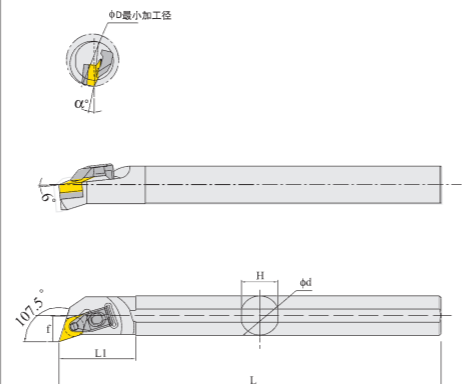

型号 Model		ØD	Ød	L	L1	H	f	a°	刀垫DN Knife pad DN	销钉DXD Pin DXD	压板DYB Pressing plate DYB	固定螺钉NLJ Fixed screw NLJ	弹簧TH Spring TH	扳手 Wrench
S25S-DDQNR/L 1504	DN□□1504□□	32	25	250	25	23	17	12	⊗	⊗				
S32T-DDQNR/L 1504		42	32	300	32	29	22.5	17	DN1504					
S40U-DDQNR/L 1504		50	40	350	40	37	26	15		DXD0614	DYB2813	NLJ0525	TH0814	L4.0
S32T-DDQNR/L 1506	DN□□1506□□	42	32	300	32	29	22.5	17	DN1504					
S40U-DDQNR/L 1506		50	40	350	40	37	26	15	DN1504					

PDUNR/L

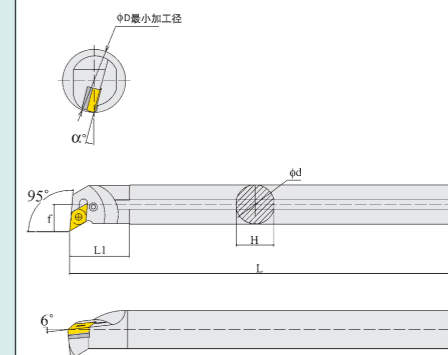

型号 Model		ØD	Ød	H	L	L1	f	a°	杠杆GGX Level GGX	螺丝NLJ-P Screw NLJ-P	垫片DN-P Spacer DN-P	垫销DX Shim DX	扳手 Wrench
S20R-PDUNR/L 11	DN□□1104□□	25	20	18	200	20	13	15	GGX0310A	NLJ0615-P	⊗	⊗	
S25S-PDUNR/L 15	DN□□1504□□	32	25	23	250	25	17	12	GGX0514A	NLJ0816-P			L3.0
S32T-PDUNR/L 15		40	32	30	300	32	22	17	GGX0514D	NLJ0821-P	DN1503-P	DX0606	
S40T-PDUNR/L 15		50	40	37	300	40	27	15					

G

压板型镗刀系列
Platen type boring cutter

G

压板型镗刀系列
Platen type boring cutter

MWLNLR/L

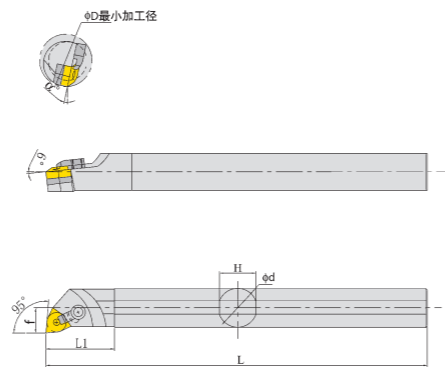

型号 Model		∅D	∅d	L	L1	H	f	a°	垫片WN Spacer WN	销钉MXD Pin MXD	压板MYB Pressing plate MYB	双头螺丝ST Double-headed Screw ST	扳手 Wrench
S16Q-MWLNLR/L 06	WN□□0604□□	21	16	180	16	15	11	18	⊗	MXD0511	MYB1811	ST0617	L2.0 L3.0
S20R-MWLNLR/L 06		27	20	200	20	18	13	15			MYB1814	ST0620	
S25S-MWLNLR/L 06		32	25	250	25	23	16.5	12			ST0625		
S20Q-MWLNLR/L 08	WN□□0804□□	25	20	180	25	18	13	15	⊗	MXD0614	MYB1811	ST0620	L2.5 L3.0
S20R-MWLNLR/L 08		25	20	200	25	18	13	15			MYB1814	ST0625	
S25R-MWLNLR/L 08		32	25	200	25	23	16.5	12			MYB1814	ST0625	
S25S-MWLNLR/L 08		32	25	250	25	23	16.5	12					
S32S-MWLNLR/L 08		41	32	250	32	29	22	17			WN0804	MXD0617	
S32T-MWLNLR/L 08		41	32	300	32	29	22	17					
S40T-MWLNLR/L 08		50	40	300	40	37	26	15					
S40U-MWLNLR/L 08	50	40	350	40	37	26	15						

PWLNLR/L

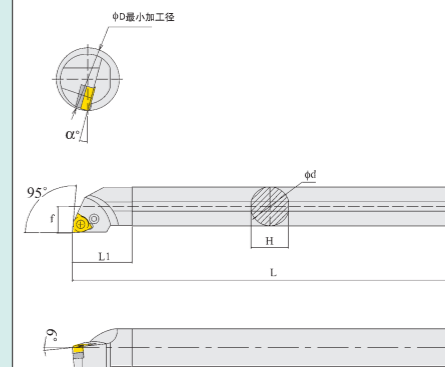

型号 Model		∅D	∅d	H	L	L1	f	a°	杠杆GGX Level GGX	螺丝NLJ-P Screw NLJ-P	垫片WN-P Spacer WN-P	垫销DX Shim DX	扳手 Wrench
S20R-PWLNLR/L 06	WN□□0604□□	25	20	18	200	25	13	12	GGX0310A	NLJ0615-P	⊗	⊗	L3.0
S25S-PWLNLR/L 08		32	25	23	250	32	17	12	GGX0514A	NLJ0816-P			
S32T-PWLNLR/L 08	WN□□0804□□	44	32	30	300	32	22	10	GGX0514	NLJ0820-P	WN0803-P	DX0606	L3.0
S40T-PWLNLR/L 08		54	40	37	300	40	27	10					

PWLNLR/L-A 内冷款 **新品**

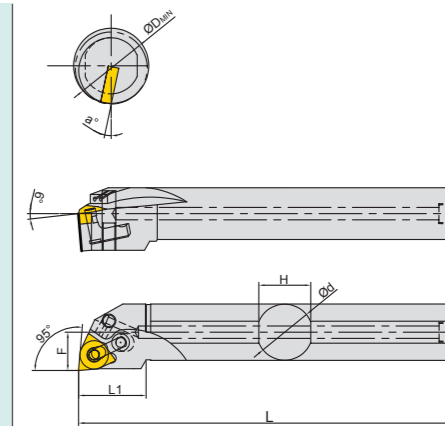

型号 Model		∅D	∅d	H	L	L1	F	a°	杠杆GGX Level GGX	螺丝NLJ-P Screw NLJ-P	垫片WN-P Spacer WN-P	垫销DX Shim DX	弹簧TH Spring TH	扳手 Wrench					
S25P-PWLNLR/L 06-A	WN□□0804□□	32	25	23	170	32	17	12	GGX0516A	NLJ0809-P	⊗	⊗	TH0607						
S25R-PWLNLR/L 08-A		32	25	23	200	32	17	12											
S25S-PWLNLR/L 08-A		32	25	23	250	32	17	12											
S32R-PWLNLR/L 08-A		44	32	29	200	32	22	17											
S32S-PWLNLR/L 08-A		44	32	29	250	32	22	17											
S32T-PWLNLR/L 08-A		44	32	29	300	32	22	17											
S40R-PWLNLR/L 08-A		54	40	37	200	40	27	15											
S40S-PWLNLR/L 08-A		54	40	37	250	40	27	15											
S40T-PWLNLR/L 08-A		54	40	37	300	40	27	15											
S40U-PWLNLR/L 08-A		54	40	37	350	40	27	15											
S25P-PWLNLR/L 06-A			32	25	23	170	32	17						12	GGX0516	NLJ0812-P	WN0803-P	DX0606	TH0608
S25R-PWLNLR/L 08-A		32	25	23	200	32	17	12											
S25S-PWLNLR/L 08-A		32	25	23	250	32	17	12											

DWLNLR/L

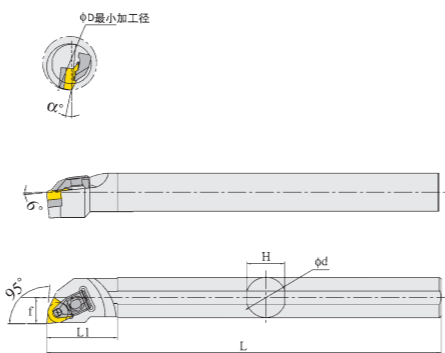

型号 Model		∅D	∅d	L	L1	H	f	a°	刀垫WN Knife pad WN	销钉DXD Pin DXD	压板DYB Pressing plate DYB	固定螺钉NLJ Fixed screw NLJ	弹簧TH Spring TH	扳手 Wrench
S20R-DWLNLR/L 08	WN□□0804□□	27	20	200	30	18	13	15	⊗	⊗	DYB2413	NLJ0525	TH0814	L4.0
S25S-DWLNLR/L 08		32	25	250	30	23	16.5	12						
S32T-DWLNLR/L 08		42	32	300	35	29	22.5	17						
S40U-DWLNLR/L 08		50	40	350	40	37	26	15						

PWLR/L

新品

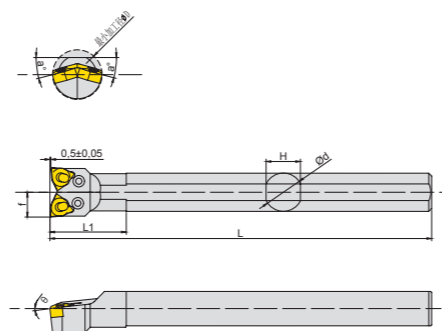

型号 Model		φD 最小加工径	φd	H	L	L1	f	a°	θ	杠杆GGX Level GGX	螺丝NLJ-P Screw NLJ-P	垫片TN-P Spacer TN-P	垫销DX Shim DX	扳手 Wrench
S20N-PWL0604-R/L	WN□□0604□□	27	20	18	160	40	13	15	6	0310A	0615			L3
S20R-PWL0604-R/L		27	20	18	200	40	13	15	6			⊗	⊗	
S25N-PWL0804-R/L	WN□□0804□□	34	25	23	160	45	16.5	12	6	0514A	0816			
S25R-PWL0804-R/L		34	25	23	200	45	16.5	12	6					
S32N-PWL0804-R/L		41	32	29	160	50	20	17	6	0514	0820	0803	0606	
S32R-PWL0804-R/L		41	32	29	200	50	20	17	6					
S32S-PWL0804-R/L		41	32	29	250	50	20	17	6					
S40N-PWL0804-R/L		47	40	37	160	55	23	15	6					
S40R-PWL0804-R/L	47	40	37	200	55	23	15	6						
S40S-PWL0804-R/L	47	40	37	250	55	23	15	6						

DVQNR/L

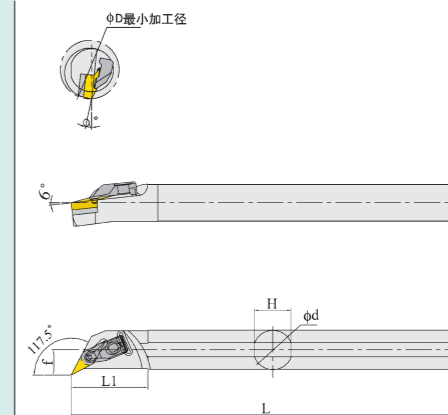

型号 Model		φD	φd	L	L1	H	f	a°	刀垫VN Knife pad VN	销钉DXD Pin DXD	压板DYB Pressing plate DYB	固定螺钉NLJ Fixed screw NLJ	弹簧TH Spring TH	扳手 Wrench
S25S-DVQNR/L 16	VN□□1604□□	32	25	250	25	23	17	12	⊗	⊗				
S32T-DVQNR/L 16		42	32	300	32	29	23	17	VN1603	DXD0512	DYB3113	NLJ0525	TH0814	L4.0
S40U-DVQNR/L 16		50	40	350	40	37	27	15						

DVUNR/L

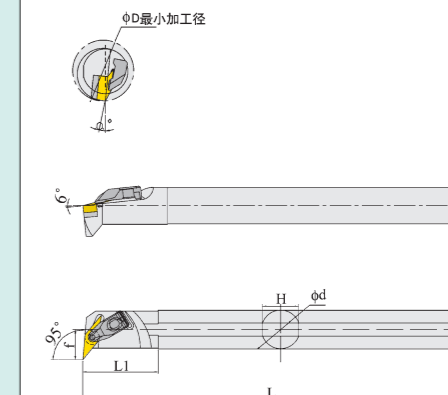
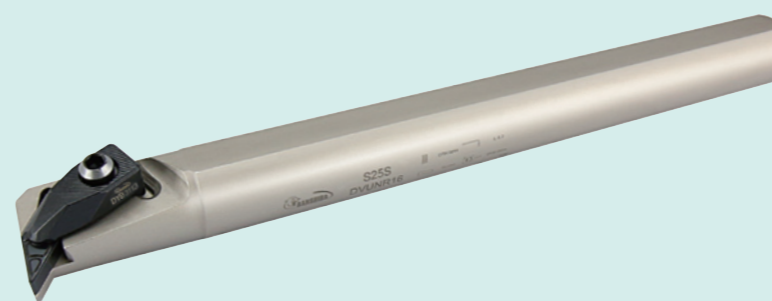

型号 Model		φD	φd	L	L1	H	f	a°	刀垫VN Knife pad VN	销钉DXD Pin DXD	压板DYB Pressing plate DYB	固定螺钉NLJ Fixed screw NLJ	弹簧TH Spring TH	扳手 Wrench
S25S-DVUNR/L 16	VN□□1604□□	36	25	250	25	23	20	12	⊗	⊗				
S32T-DVUNR/L 16		42	32	300	32	29	23	17	VN1603	DXD0512	DYB3113	NLJ0525	TH0814	L4.0
S40U-DVUNR/L 16		50	40	350	40	37	26	15						

DVXNR/L

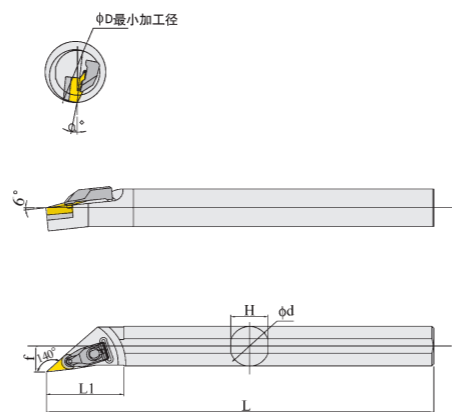

型号 Model		∅D	∅d	L	L1	H	f	a°	刀垫VN Knife pad VN	销钉DXD Pin DXD	压板DYB Pressing plate DYB	固定螺钉NLJ Fixed screw NLJ	弹簧TH Spring TH	扳手 Wrench
S20R-DVXNR/L 16	VN□□1604□□	27	20	200	40	18	14	15	⊗	⊗	DYB3113	NLJ0525	TH0814	L4.0
S25S-DVXNR/L 16		32	25	250	45	23	17	12						
S32T-DVXNR/L 16		42	32	300	50	29	23	17						
S40U-DVXNR/L 16		50	40	350	55	37	27	15	VN1603 DXD0512					

DVWNR/L

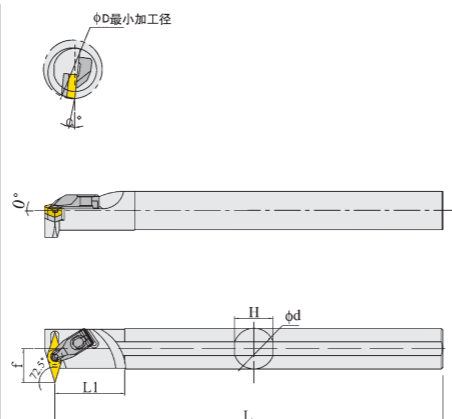

型号 Model		∅D	∅d	L	L1	H	f	a°	刀垫VN Knife pad VN	销钉DXD Pin DXD	压板DYB Pressing plate DYB	固定螺钉NLJ Fixed screw NLJ	弹簧TH Spring TH	扳手 Wrench
S25S-DVWNR/L 16	VN□□1604□□	38	25	250	25	23	23	12	⊗	⊗	DYB3113	NLJ0525	TH0814	L4.0
S32T-DVWNR/L 16		46	32	300	32	29	27.5	17	VN1603 DXD0512					

螺钉型镗刀

SCREW TYPE BORING CUTTER

目录

95° 内径镗刀(H1) SCLCR/L 变杆	95° 内径(H1) SCLCR/L-A	95° 内径(H2) SCLCR/L	95° 内径(H2) SCLR/L	75° 内径(H3) SCKCR/L
93° 内径(H3) SCZCR/L	45° 内径(H4) SSSCR/L	75° 内径(H4) SSKCR/L	107.5° 内径(H5) SDQCR/L	93° 内径(H5) SDZCR/L
95° 内径(H6) SDUCR/L	62.5° 内径(H6) SDWCR/L	93° 内径(H7) SDJCR/L	91° 内径镗刀(H8) STFCR/L	95° 内径镗刀(H8) STUPR/L
95° 内径镗刀(H9) STUCR/L	60° 内径镗刀(H9) STWCR/L	93° 内径(H10) STUNR/L	120° 内径(H10) STWNR/L	117.5° 内径(H11) SVQC(B)R/L
95° 内径(H11) SVUC(B)R/L	139° 内径(H12) SVXC(B)R/L	93° 内径(H12) SVZC(B)R/L	72.5° 内径(H13) SVWC(B)R/L	95° 内径(H14) SWUBR/L
95° 内径(H14) SWLCR/L	93° 内径(H15) SWUNR/L	93° 内径(H16) SWUR/L	镗孔刀刀套(H17) 	

SCLCR/L 变杆

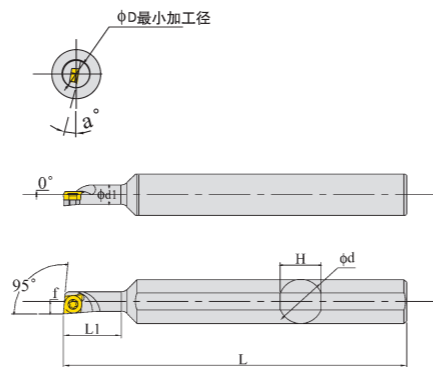

型号 Model		ϕD	ϕd	ϕd_1	f	L	L1	H	a°	螺丝 Screw	扳手 Wrench
S0612K-SCLCR/L 04	CC□□0402□□	7	12	6	3.5	125	18	11	10	M2*4	T-6
S0812K-SCLCR/L 06	CC□□0602□□	10	12	8	5	125	24	11	10	M2.5*6	T-8
S0616M-SCLCR/L 04	CC□□0402□□	7	16	6	3.5	150	18	15	10	M2*4	T-6
S0816M-SCLCR/L 06	CC□□0602□□	10	16	8	5	150	24	15	10	M2.5*6	T-8
S1016M-SCLCR/L 06		13	16	10	6	150	30	15	10		
S1216M-SCLCR/L 06		16	16	12	7	150	36	15	10		
S1020M-SCLCR/L 06		13	20	10	6	150	30	18	8		
S1220M-SCLCR/L 06		16	20	12	7	150	36	18	8		
S1220M-SCLCR/L 09	CC□□09T3□□	16	20	12	7.5	150	36	18	8	M3.5*8	T-15

SCLCR/L-A 内冷款 **新品**

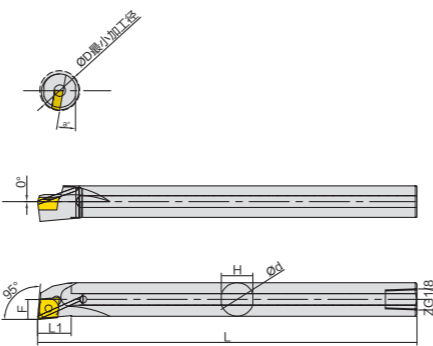

型号 Model		ϕD	ϕd	L	L1	F	H	a°	螺丝 Screw	扳手 Wrench
S07K-SCLCR/L06-A	CC□□0602□□	9	7	125	14	4.5	6	15	M2.5*6	T-8
S08K-SCLCR/L06-A		10	8	125	16	5	7	13		
S10K-SCLCR/L06-A		13	10	125	16	6	9	12		
S12M-SCLCR/L06-A	CC□□09T3□□	16	12	150	16	7	11	10	M3.5*8	T-15
S14N-SCLCR/L09-A		18	14	160	16	8.5	13	12		
S16Q-SCLCR/L09-A		20	16	180	16	9.5	15	10		
S20R-SCLCR/L09-A		25	20	200	25	11.5	18	8		

SCLCR/L

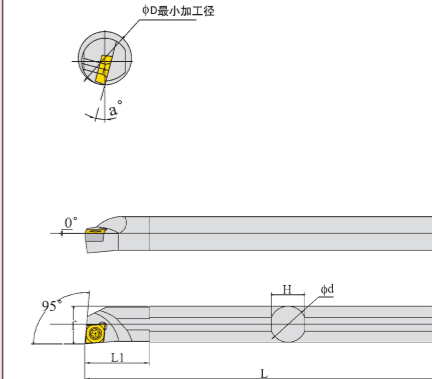

型号 Model		ϕD	ϕd	f	L	L1	H	a°	螺丝 Screw	扳手 Wrench
S07K-SCLCR/L 06	CC□□0602□□	9	7	4.5	125	14	6	15	M2.5*6	T-8
S08K-SCLCR/L 06		10	8	5	125	16	7	13		
S10K-SCLCR/L 06		13	10	6	125	16	9	12		
S12M-SCLCR/L 06		16	12	7	150	16	11	10		
S12M-SCLCR/L 09	CC□□09T3□□	16	12	7.5	150	16	11	12	M3.5*8	T-15
S14N-SCLCR/L 09		18	14	8.5	160	16	13	12		
S14Q-SCLCR/L 09		18	14	8.5	180	16	13	12		
S16N-SCLCR/L 09		20	16	9.5	160	16	15	10		
S16Q-SCLCR/L 09		20	16	9.5	180	16	15	10		
S18Q-SCLCR/L 09		22	18	10.5	180	20	17	10		
S20Q-SCLCR/L 09		25	20	11.5	180	20	18	8		
S20R-SCLCR/L 09		25	20	11.5	200	25	18	8		
S25R-SCLCR/L 09		31	25	14	200	20	23	6		
S25S-SCLCR/L 09		31	25	14	250	20	23	6		
S20Q-SCLCR/L 12	CC□□1204□□	25	20	12	180	25	18	8	M5*12	T-20
S20R-SCLCR/L 12		25	20	12	200	25	18	8		
S25R-SCLCR/L 12		31	25	14.5	200	25	23	6		
S25S-SCLCR/L 12		31	25	14.5	250	25	23	6		
S32S-SCLCR/L 12		39	32	18	250	32	29	4		
S32T-SCLCR/L 12		39	32	18	300	32	29	4		

SCLR/L **新品**

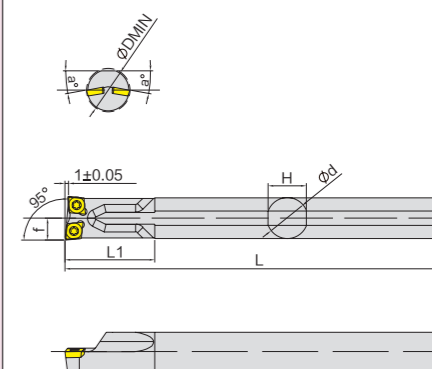

型号 Model		ϕD	ϕd	f	L	L1	H	a°	螺丝 Screw	扳手 Wrench
S16M-SCL0602-R/L	CC□□0602□□	18	16	8.5	150	35	15	10	M2.5*6	T-8
S16Q-SCL0602-R/L		18	16	8.5	150	35	15	10		

螺钉型镗刀 Screw type boring cutter

螺钉型镗刀 Screw type boring cutter

H

H

SCKCR/L

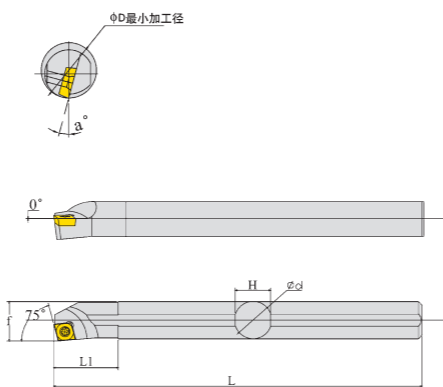

型号 Model		ØD	Ød	f	L	L1	H	a°	螺丝 Screw 	扳手 Wrench
S08K-SCKCR/L 06	CC□□0602□□	10.5	8	5.5	125	16	5	13	M2.5*6	T-8
S10K-SCKCR/L 06		13.5	10	6	125	16	9	12		
S12M-SCKCR/L 06	CC□□09T3□□	16	12	7	150	16	11	10	M3.5*8	T-15
S12M-SCKCR/L 09		16	12	7.5	150	20	11	12		
S16N-SCKCR/L 09		20	16	9.5	160	20	15	10		
S16Q-SCKCR/L 09		20	16	9.5	180	20	15	10		
S20Q-SCKCR/L 09		25	20	11.5	180	20	18	8		
S20R-SCKCR/L 09		25	20	11.5	200	25	18	8		
S25R-SCKCR/L 09		31	25	14	200	25	23	6		
S25S-SCKCR/L 09		31	25	14	250	25	23	6		

SCZCR/L

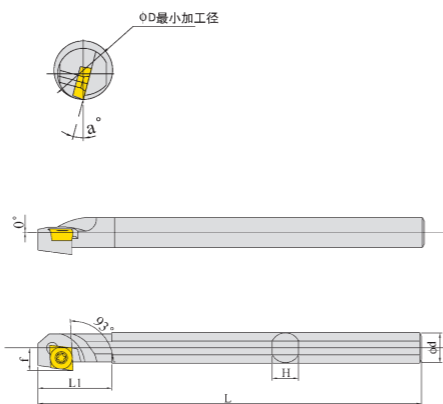

型号 Model		ØD	Ød	f	L	L1	H	a°	螺丝 Screw 	扳手 Wrench
S08K-SCZCR/L 06	CC□□0602□□	12.5	8	6.5	125	16	7	13	M2.5*6	T-8
S10K-SCZCR/L 06		14	10	7.5	125	16	9	12		
S12M-SCZCR/L 06	CC□□09T3□□	16	12	8.5	150	16	11	10	M3.5*8	T-15
S16Q-SCZCR/L 09		20	16	11	180	20	15	10		
S20R-SCZCR/L 09		25	20	13.5	200	25	18	8		
S25S-SCZCR/L 09		32	25	16	250	30	23	6		

SSSCR/L

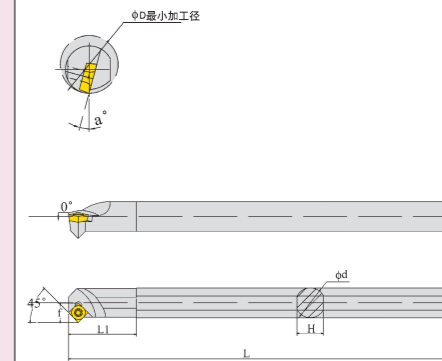

型号 Model		ØD	Ød	f	L	L1	H	a°	螺丝 Screw 	扳手 Wrench
S12M-SSSCR/L 09	SC□□09T3□□	16	12	8.5	150	16	11	12	M3.5*8	T-15
S16N-SSSCR/L 09		22	16	11.5	160	16	15	10		
S20R-SSSCR/L 09		26	20	13.5	200	25	18	8		
S25S-SSSCR/L 09		31	25	16	250	25	23	6		
S20R-SSSCR/L 12	SC□□1204□□	26	20	14	200	25	18	8	M5*12	T-20
S25S-SSSCR/L 12		31	25	16.5	250	25	23	6		

SSKCR/L

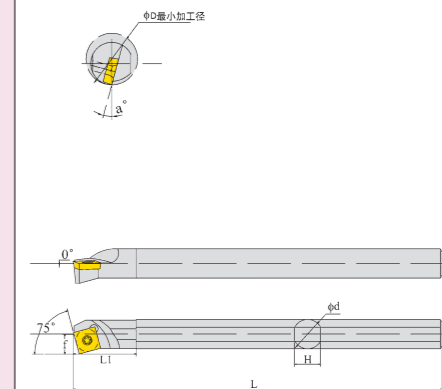

型号 Model		ØD	Ød	f	L	L1	H	a°	螺丝 Screw 	扳手 Wrench
S12M-SSKCR/L 09	SC□□09T3□□	16	12	8.5	150	16	11	12	M3.5*8	T-15
S16Q-SSKCR/L 09		20	16	10.5	180	16	15	10		
S20R-SSKCR/L 09		24	20	12.5	200	25	18	8		
S25S-SSKCR/L 09		31	25	15	250	25	23	6		
S20R-SSKCR/L 12	SC□□1204□□	24	20	13	200	25	18	8	M5*12	T-20
S25S-SSKCR/L 12		31	25	15.5	250	25	23	6		

SDQCR/L

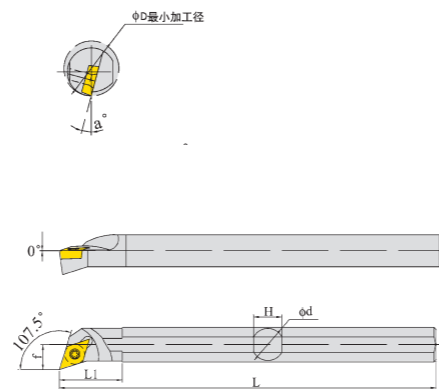

型号 Model		ϕD	ϕd	f	L	L1	H	a°	螺丝 Screw	扳手 Wrench
S08K-SDQCR/L 07	DC□□0702□□	13	8	6	125	16	7	12	M2.5*6	T-8
S10K-SDQCR/L 07		16	10	7	125	16	9	10		
S12M-SDQCR/L 07		20	12	9	150	16	11	8		
S16N-SDQCR/L 07		25	16	10.5	160	16	15	6		
S16Q-SDQCR/L 07		25	16	10.5	180	16	15	6		
S16N-SDQCR/L 11		DC□□11T3□□	25	16	11	160	16	15		
S16Q-SDQCR/L 11	25		16	11	180	16	15	6		
S20Q-SDQCR/L 11	28		20	13	180	20	18	6		
S20R-SDQCR/L 11	28		20	13	200	25	18	6		
S25R-SDQCR/L 11	33		25	16	200	25	23	4		
S25S-SDQCR/L 11	33		25	16	250	25	23	4		
S32S-SDQCR/L 11	41		32	20	250	32	29	4		
S32T-SDQCR/L 11	41	32	20	300	32	29	4			

SDUCR/L

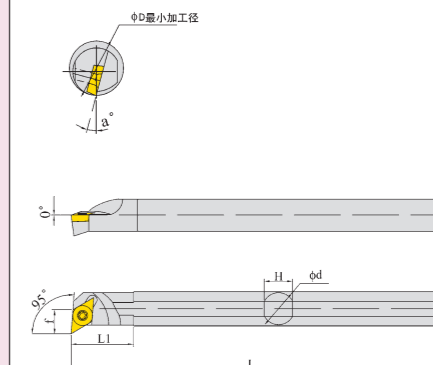

型号 Model		ϕD	ϕd	f	L	L1	H	a°	螺丝 Screw	扳手 Wrench
S08K-SDUCR/L 07	DC□□0702□□	13	8	7	125	16	7	12	M2.5*6	T-8
S10K-SDUCR/L 07		15	10	8	125	16	9	10		
S12M-SDUCR/L 07		17	12	9	150	16	11	8		
S14N-SDUCR/L 07		20	14	10	160	16	13	8		
S16N-SDUCR/L 07		22	16	11	160	16	15	6		
S16Q-SDUCR/L 07		22	16	11	180	16	15	6		
S16N-SDUCR/L 11	DC□□11T3□□	23	16	11.5	160	16	15	8	M3.5*8	T-15
S16Q-SDUCR/L 11		23	16	11.5	180	16	15	8		
S20Q-SDUCR/L 11		25	20	13	180	20	18	6		
S20R-SDUCR/L 11		25	20	13	200	25	18	6		
S25S-SDUCR/L 11		32	25	16	250	25	23	4		
S25R-SDUCR/L 11		32	25	16	200	25	23	4		
S32S-SDUCR/L 11		39	32	20	250	32	29	4		
S32T-SDUCR/L 11	39	32	20	300	32	29	4			

SDZCR/L

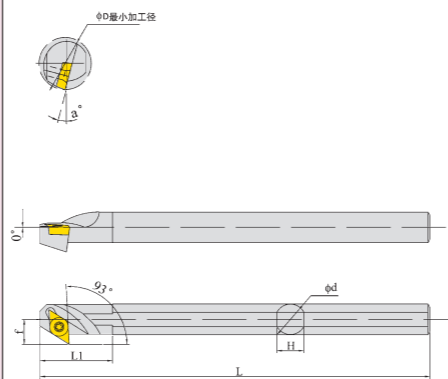

型号 Model		ϕD	ϕd	f	L	L1	H	a°	螺丝 Screw	扳手 Wrench
S10K-SDZCR/L 07	DC□□0702□□	16	10	8	125	16	9	12	M2.5*6	T-8
S12M-SDZCR/L 07		18	12	9	150	16	11	10		
S16Q-SDZCR/L 07		22	16	11	180	16	15	8		
S16Q-SDZCR/L 11	DC□□11T3□□	24	16	12	180	16	15	8	M3.5*8	T-15
S20R-SDZCR/L 11		28	20	13	200	25	18	8		
S25S-SDZCR/L 11		34	25	16	250	25	23	6		
S32T-SDZCR/L 11		38	32	20.5	300	32	29	4		

SDWCR/L

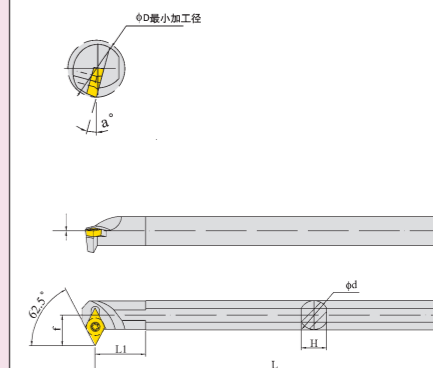

型号 Model		ϕD	ϕd	f	L	L1	H	a°	螺丝 Screw	扳手 Wrench
S10K-SDWCR/L 07	DC□□0702□□	16	10	9.5	125	16	9	12	M2.5*6	T-8
S12M-SDWCR/L 07		19	12	10.5	150	16	11	10		
S16N-SDWCR/L 07		23	16	12.5	160	16	15	8		
S16Q-SDWCR/L 11	DC□□11T3□□	23	16	14	180	16	15	8	M3.5*8	T-15
S20R-SDWCR/L 11		25.5	20	14.5	200	25	19	6		
S25S-SDWCR/L 11		32	25	17	250	25	24	4		
S32T-SDWCR/L 11		40	32	20	300	32	30	4		

SDJCR/L

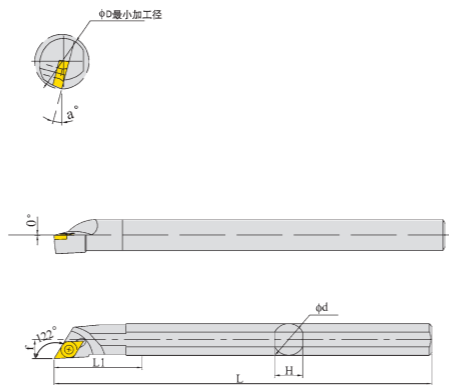

型号 Model		∅D	∅d	f	L	L1	H	a°	螺丝 Screw	扳手 Wrench
S08K-SDJCR/L 07	DC□□0702□□	10	8	5.5	125	16	7	12	M2.5*6	T-8
S10K-SDJCR/L 07		12	10	6.5	125	16	9	10		
S12M-SDJCR/L 07		15	12	7.5	150	16	11	8		
S16N-SDJCR/L 07		20	16	10.5	160	20	15	6		
S16Q-SDJCR/L 07		20	16	10.5	180	20	15	6		
S20Q-SDJCR/L 11	DC□□11T3□□	24	20	13	180	25	18	6	M3.5*8	T-15
S20R-SDJCR/L 11		24	20	13	200	25	18	6		
S25S-SDJCR/L 11		30	25	15.5	250	25	23	4		

STFCR/L

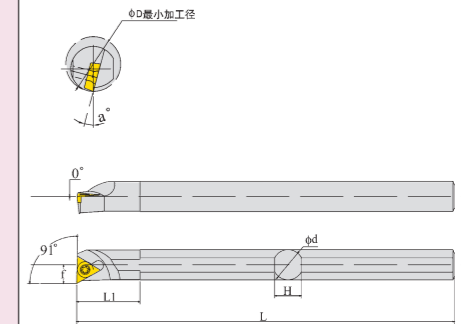

型号 Model		∅D	∅d	f	L	L1	H	a°	螺丝 Screw	扳手 Wrench
S08K-STFCR/L 09	TC□□0902□□	11	8	5	125	16	7	15	M2.2*6	T-6
S10K-STFCR/L 09		13	10	6	125	16	9	13		
S12M-STFCR/L 09		16	12	7	150	16	11	10		
S10K-STFCR/L 11		13	10	6	125	16	9	12		
S12M-STFCR/L 11		16	12	7	150	16	11	10		
S14N-STFCR/L 11	TC□□1102□□	18	14	8	160	16	13	10	M2.5*6	T-8
S14Q-STFCR/L 11		18	14	8	180	16	13	10		
S16N-STFCR/L 11		20	16	9	160	16	15	8		
S16Q-STFCR/L 11		20	16	9	180	16	15	8		
S20Q-STFCR/L 11		25	20	11	180	25	18	6		
S20R-STFCR/L 11	TC□□16T3□□	25	20	11	200	25	18	6	M3.5*8	T-15
S16Q-STFCR/L 16		20	16	9	180	16	15	8		
S20Q-STFCR/L 16		25	20	11.5	180	25	18	8		
S20R-STFCR/L 16		25	20	11.5	200	25	18	8		
S25R-STFCR/L 16		31	25	14	200	25	23	6		
S25S-STFCR/L 16		31	25	14	250	25	23	6		
S32S-STFCR/L 16		39	32	17.5	250	32	29	4		
S32T-STFCR/L 16	39	32	17.5	300	32	29	4			

STUPR/L

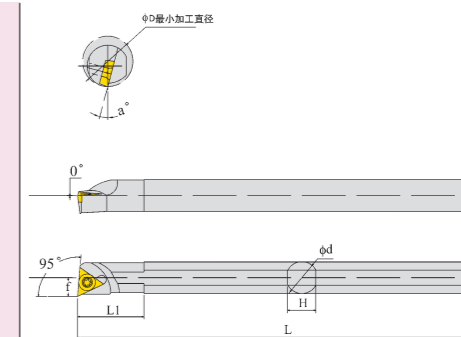

型号 Model		∅D	∅d	f	L	L1	H	a°	螺丝 Screw	扳手 Wrench
S08K-STUPR/L 09	TP□□0902□□	10	8	5	125	16	7	15	M2.5*6	T-8
S10K-STUPR/L 09		13	10	6	125	16	9	13		
S12K-STUPR/L 09		16	12	7	125	16	11	13		
S10K-STUPR/L 11		13	10	6	125	16	9	12		
S12M-STUPR/L 11		16	12	7	150	16	11	10		
S16Q-STUPR/L 11	TP□□1103□□	20	16	9	180	16	15	8	M3.0*7	T-8
S20R-STUPR/L 11		25	20	11	200	25	18	6		
S16Q-STUPR/L 16		20	16	9.5	180	16	15	8		
S20R-STUPR/L 16		25	20	11.5	200	25	18	8		
S25S-STUPR/L 16		31	25	14	250	25	23	6		
S32T-STUPR/L 16	TP□□1603□□	39	32	17.5	300	32	29	4	M3.5*8	T-15

螺钉型镗刀 Screw type boring cutter

螺钉型镗刀 Screw type boring cutter

H

H

STUCR/L

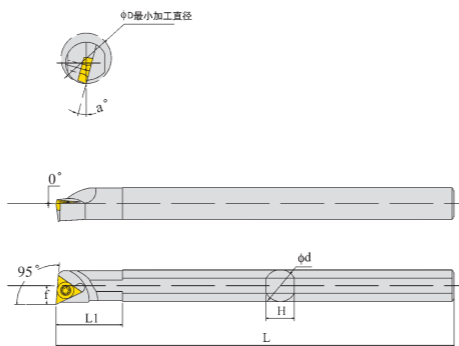

型号 Model		ϕD	ϕd	f	L	L1	H	a°	螺丝 Screw	扳手 Wrench
S06H-STUBR/L 06	TB□□0601□□	7	6	3.5	100	15	5.4	15	M2.0*4	T-6
S08K-STUCR/L 09	TC□□0902□□	10	8	5	125	16	7	15	M2.2*5	T-8
S10K-STUCR/L 09		13	10	6	125	16	9	13		
S12K-STUCR/L 09		16	12	7	125	16	11	13		
S10K-STUCR/L 11		13	10	6	125	16	9	12		
S12M-STUCR/L 11	TC□□1102□□	16	12	7	150	16	11	10	M2.5*6	T-8
S14N-STUCR/L 11		18	14	8	160	16	13	10		
S16N-STUCR/L 11		20	16	9	160	16	15	8		
S16Q-STUCR/L 11		20	16	9	180	16	15	8		
S20Q-STUCR/L 11		25	20	11	180	25	19	6		
S20R-STUCR/L 11		25	20	11	200	25	19	6		
S16N-STUCR/L 16	TC□□16T3□□	20	16	9.5	180	16	15	8	M3.5*8	T-15
S16Q-STUCR/L 16		20	16	9.5	160	16	15	8		
S20Q-STUCR/L 16		25	20	11.5	180	25	18	8		
S20R-STUCR/L 16		25	20	11.5	200	25	18	8		
S25R-STUCR/L 16		31	25	14	200	25	23	6		
S25S-STUCR/L 16		31	25	14	250	25	23	6		
S32S-STUCR/L 16		39	32	17.5	250	32	29	4		
S32T-STUCR/L 16	39	32	17.5	300	32	29	4			

STUNR/L 新品

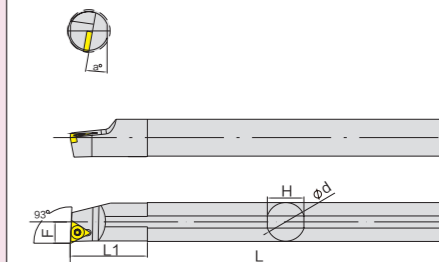

型号 Model		ϕD	ϕd	H	L	L1	F	a°	螺丝 Screw	扳手 Wrench
S12M-STUNR/L 12	TN□□1204□□	14	12	11	150	27	7	14	M3*8	T10
S14N-STUNR/L 12		16	14	13	160	30	8	14		
S16Q-STUNR/L 12		18	16	15	180	40	9	12		
S20R-STUNR/L 12		22	20	19	200	40	11	10		

STWCR/L

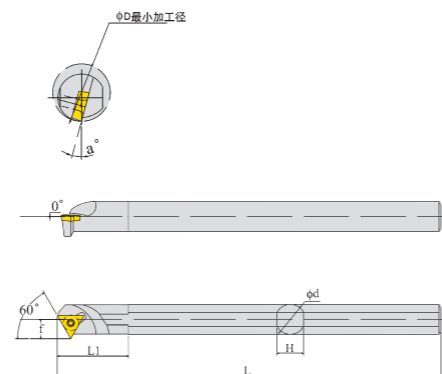

型号 Model		ϕD	ϕd	f	L	L1	H	a°	螺丝 Screw	扳手 Wrench
S08K-STWCR/L 09	TC□□0902□□	11	8	5.5	125	16	7	13	M2.2*6	T-6
S10K-STWCR/L 09		13	10	6.5	125	16	9	12		
S10K-STWCR/L 11	TC□□1102□□	14	10	8	125	16	9	12	M2.5*6	T-8
S12M-STWCR/L 11		16	12	9	150	16	11	10		
S14N-STWCR/L 11		18	14	10	160	16	13	10		
S16Q-STWCR/L 11		20	16	11	180	16	15	10		
S16Q-STWCR/L 16	TC□□16T3□□	21	16	12	180	16	15	10	M3.5*8	T-15
S20R-STWCR/L 16		25	20	14.5	200	25	18	8		
S25S-STWCR/L 16		32	25	17	250	25	23	6		

STWNR/L 新品

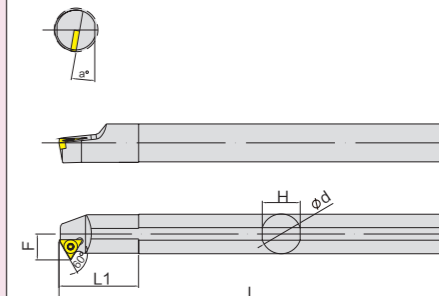

型号 Model		ϕD	ϕd	H	L	L1	F	a°	螺丝 Screw	扳手 Wrench
S12M-STWNR/L 12	TN□□1204□□	16	12	11	150	27	9	14	M3*8	T10
S14N-STWNR/L 12		18	14	13	160	30	10	14		
S16Q-STWNR/L 12		20	16	15	180	40	11	12		
S20R-STWNR/L 12		24	20	19	200	40	13	10		

SVQC(B)R/L

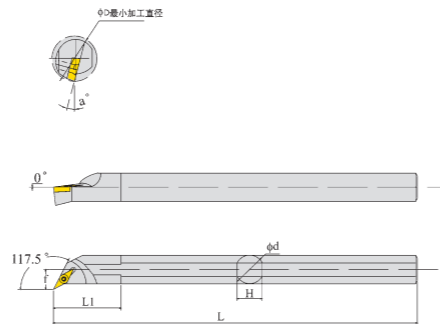

型号 Model		ϕD	ϕd	f	L	L1	H	a°		螺丝 Screw	扳手 Wrench
								B	C		
S16Q-SVQC(B)R/L 11	VC(B)□□1103□□	22	16	11.5	180	16	15	12	10	M2.5*6	T-8
S20R-SVQC(B)R/L 11		27	20	14	200	25	18	12	8		
S20R-SVQC(B)R/L 16		27	20	14	200	25	18	12	8		
S25S-SVQC(B)R/L 16	VC(B)□□1604□□	32	25	16.5	250	25	23	8	6	M3.5*8	T-15
S32T-SVQC(B)R/L 16		41	32	22.5	300	32	29	8	4		

SVXC(B)R/L

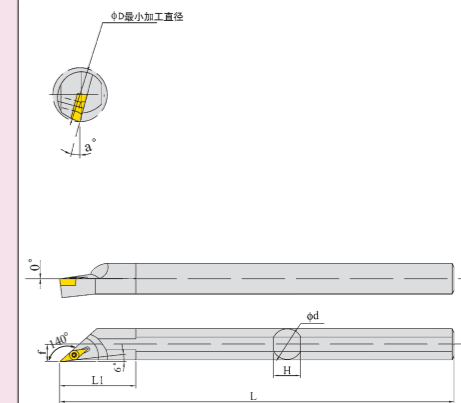

型号 Model		ϕD	ϕd	f	L	L1	H	a°		螺丝 Screw	扳手 Wrench
								B	C		
S16Q-SVXC(B)R/L 11	VC(B)□□1103□□	22	16	11	150	16	15	12	10	M2.5*6	T-8
S20R-SVXC(B)R/L 11		27	20	13.5	200	25	18	12	8		
S20R-SVXC(B)R/L 16		27	20	13.5	200	25	18	12	8		
S25S-SVXC(B)R/L 16	VC(B)□□1604□□	32	25	16	250	25	23	8	6	M3.5*8	T-15
S32T-SVXC(B)R/L 16		41	32	19.5	300	32	29	8	4		

SVUC(B)R/L

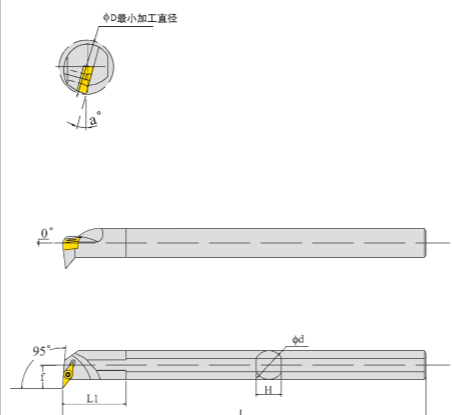

型号 Model		ϕD	ϕd	f	L	L1	H	a°		螺丝 Screw	扳手 Wrench
								B	C		
S16Q-SVUC(B)R/L 11	VC(B)□□1103□□	22	16	11.5	180	16	15	12	10	M2.5*6	T-8
S20R-SVUC(B)R/L 11		27	20	14	200	25	18	12	8		
S20R-SVUC(B)R/L 16		27	20	19	200	25	18	12	8		
S25S-SVUC(B)R/L 16	VC(B)□□1604□□	33	25	20	250	25	23	8	6	M3.5*8	T-15
S32T-SVUC(B)R/L 16		41	32	22.5	300	32	29	8	4		

SVZC(B)R/L

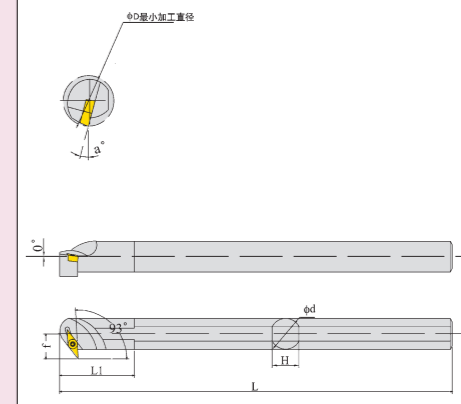
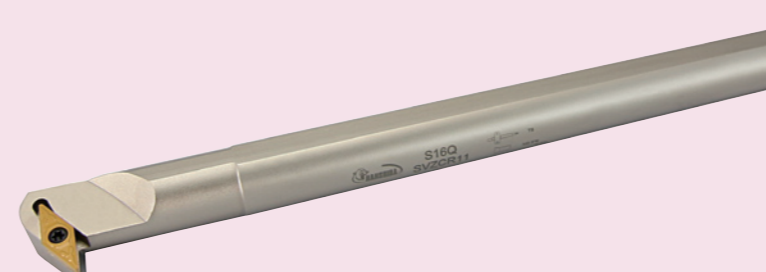

型号 Model		ϕD	ϕd	f	L	L1	H	a°		螺丝 Screw	扳手 Wrench
								B	C		
S16Q-SVZC(B)R/L 11	VC(B)□□1103□□	22	16	11.5	150	16	15	12	10	M2.5*6	T-8
S20R-SVZC(B)R/L 11		27	20	14	200	25	18	12	8		
S20R-SVZC(B)R/L 16		27	20	14	200	25	18	12	8		
S25S-SVZC(B)R/L 16	VC(B)□□1604□□	32	25	19	250	25	23	8	6	M3.5*8	T-15
S32T-SVZC(B)R/L 16		41	32	23.5	300	32	29	8	4		

SVWC(B)R/L

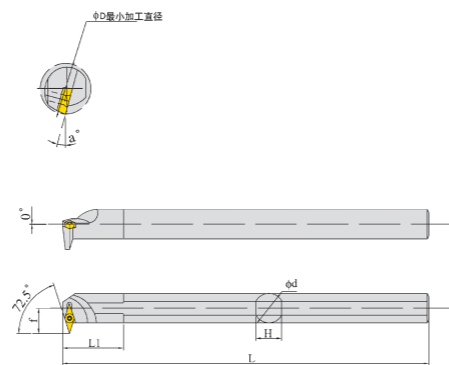

型号 Model		ØD	Ød	f	L	L1	H	a°		螺丝 Screw	扳手 Wrench
								B	C		
S25S-SVWC(B)R/L 16	VC(B)□□1604□□	38	25	23	250	25	23	6	6	M3.5*8	T-15
S32T-SVWC(B)R/L 16		45	32	26	300	32	29	6	4		

SWUBR/L

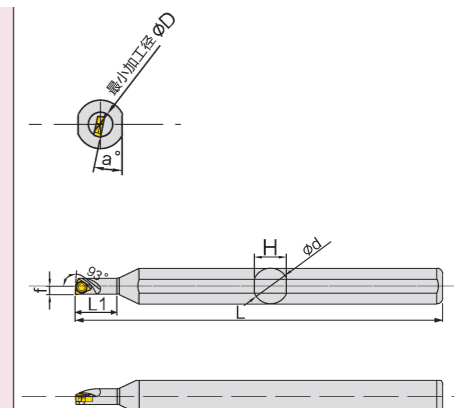

型号 Model		ØD	Ød	f	L	L1	H	a°	螺丝 Screw	扳手 Wrench
S0610K-SWUBR/L06-L18	7	10	3.5	125	18	9	12			
S0710K-SWUBR/L06-L20	8	10	4	125	20	9	12			
S0512K-SWUBR/L06-L15	6	12	3	125	15	11	12			
S0612K-SWUBR/L06-L18	7	12	3.5	125	18	11	12			
S0712K-SWUBR/L06-L20	8	12	4	125	20	11	12			

SWLCR/L

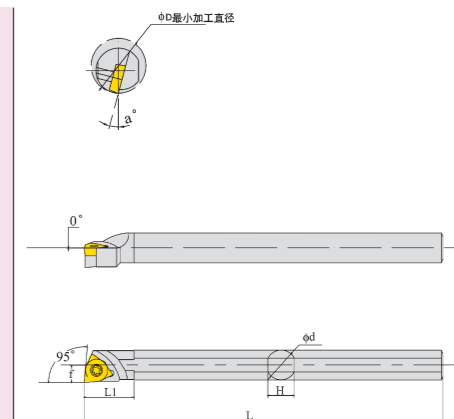

型号 Model		ØD	Ød	f	L	L1	H	a°	螺丝 Screw	扳手 Wrench
S10K-SWLCR/L 04	13	10	6.5	125	16	9	10			
S12M-SWLCR/L 06	WC□□06T3□□	16	12	8	150	16	11	13	M3.5*8	T-15
S16Q-SWLCR/L 06		20	16	10	180	16	15	10		
S20R-SWLCR/L 08		25	20	12	200	25	19	8		
S25S-SWLCR/L 08	WC□□0804□□	31	25	14.5	250	25	24	6	M5*12	T-20

SWUNR/L

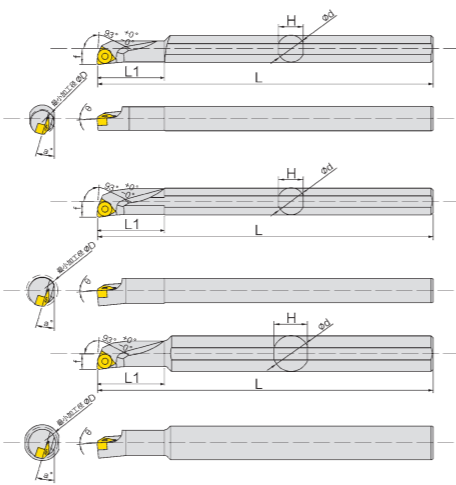
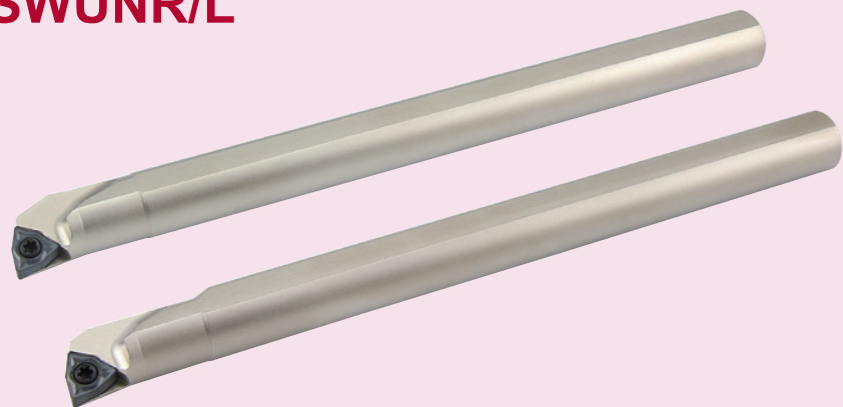

型号 Model		∅D	∅d	f	L	L1	H	a°	螺丝 Screw 	扳手 Wrench
S10K-SWUNR/L 04	WNMU0403□□	13	10	6	125	25	9	4	M2.5*7	T-8
S12M-SWUNR/L 04		15	12	7	150	30	11	4		
S14N-SWUNR/L 04		17	14	8	160	35	13	4		
S16Q-SWUNR/L 04		19	16	9	180	40	15	4		
S16Q-SWUNR/L 06	WNMU06T3□□	19	16	9	180	40	15	6	M3.5*9	T-10
S18Q-SWUNR/L 06		21	18	10	180	40	17	6		
S20R-SWUNR/L 06		23	20	11	200	45	18	6		
S25S-SWUNR/L 06		28	25	13.5	250	45	23	6		
S10K-SWUNR/L 04-10	WNMU0403□□	10	10	6	125	25	9	4	M2.5*7	T-8
S12M-SWUNR/L 04-11		11	12	7	150	30	11	4		
S14N-SWUNR/L 04-13		13	14	8	160	35	13	4		
S16Q-SWUNR/L 04-15		15	16	9	180	40	15	4		
S16Q-SWUNR/L 06-15	WNMU06T3□□	15	16	9	180	40	15	6	M3.5*9	T-10
S18Q-SWUNR/L 06-17		17	18	10	180	42.5	17	6		
S20R-SWUNR/L 06-19		19	20	11	200	47.5	18	6		
S25S-SWUNR/L 06-24		24	25	13.5	250	60	23	6		
S1016M-SWUNR/L 04	WNMU0403□□	13	16	6	150	25	15	4	M2.5*7	T-8
S1216M-SWUNR/L 04		15	16	7	150	30	15	4		
S1416M-SWUNR/L 04		17	16	8	150	35	15	4		
S1020M-SWUNR/L 04		13	20	6	150	25	18	4		
S1220M-SWUNR/L 04		15	20	7	150	30	18	4		
S1420M-SWUNR/L 04		17	20	8	150	35	18	4		
S1620M-SWUNR/L 04	19	20	9	150	40	18	4			
S1820M-SWUNR/L 04		21	20	10	150	45	18	4		

注：此款为新款最经济的小孔内径刀

SWUR/L **新品**

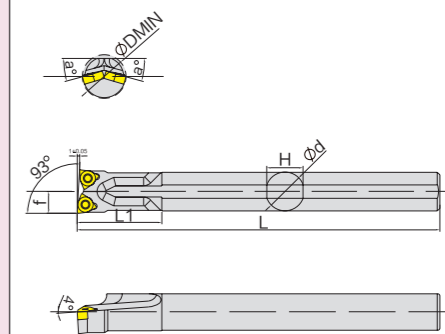
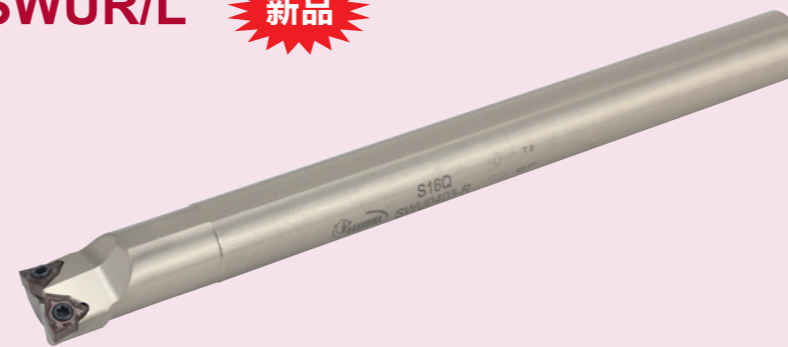

型号 Model		∅D	∅d	f	L	L1	H	a°	螺丝 Screw 	扳手 Wrench
S16M-SWU0403-R/L	WN□□0403□□	19	16	9	150	35	15	15	M2.5*6	T-8
S16Q-SWU0403-R/L		19	16	9	180	35	15	15		
S20N-SWU0403-R/L		23	20	11	160	35	18	15		
S20R-SWU0403-R/L		23	20	11	200	35	18	15		

镗孔刀刀套

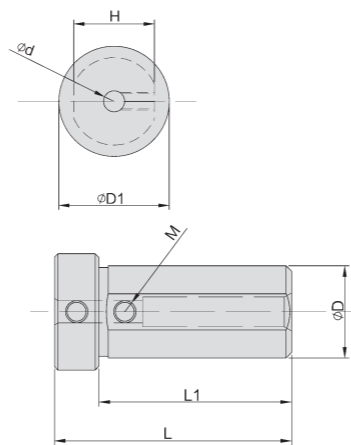

型号 Model	适用条件							型号 Model	适用条件						
	φD	φD1	φd	H	L	L1	M		φD	φD1	φd	H	L	L1	M
NC16-04			4					NC32-12			12				
NC16-06			6				M5	NC32-14			14				
NC16-08	16	19	8	15	62	55		NC32-16			16				
NC16-10			10				M6	NC32-18	32	38	18	30	100	85	M8
NC16-12			12					NC32-20			20				
NC20-06			6					NC32-25			25				
NC20-08			8					NC40-07			7				M6
NC20-10			10					NC40-08			8				
NC20-12	20	27	12	18	67	60	M6	NC40-10			10				
NC20-14			14					NC40-12			12				
NC20-16			16					NC40-14			14				
NC25-06			6				M6	NC40-16	40	46	16	38	100	85	M8
NC25-08			8					NC40-18			18				
NC25-10			10					NC40-20			20				
NC25-12			12					NC40-25			25				
NC25-14	25	35	14	23	64	58	M8	NC40-32			32				
NC25-16			16					NC50-08			8				
NC25-18			18					NC50-10			10				
NC25-20			20					NC50-12			12				
NC32-05			5				M6	NC50-16	50	58	16	48	100	85	M8
NC32-06			6					NC50-20			20				
NC32-07	32	38	7	30	100	85		NC50-25			25				
NC32-08			8					NC50-32			32				
NC32-10			10				M8	NC50-40			40				

割刀 螺纹刀
Cutting knife Chaser



高速加工 高韧性 高刚性

螺钉型镗刀 Screw type boring cutter

H

外径割刀(I1)	外径割刀(I2)	外径割刀(I3)	外径割刀(I4-I5)	外径割刀(I6)
TTER/L	MGEHR/L	MGEHR/L-A	MGEHR/L-T	KGMR/L
外径割刀(I7)	外径割刀(I8)	外径割刀(I9)	外径割刀(I9)	外径割刀(I10)
KGMR/L-T	QE□DR/L	GHDR/L	GHGR/L	MGEVR/L
外径割刀(I10)	外径割刀(I11)	小径镗孔刀(I12)	小径镗孔刀(I12)	外径割刀(I13)
MGEVR/L-T	MGWHR/L	SVNR	S-SVNR	SGEL
外径割刀(I13)	外径割刀(I14)	内径割刀(I15)	内径割刀(I16-I17)	内径割刀(I18)
B-SGEL	MGENN	MGNVR/L-A	MGNVR/L	KIGMR/L
内径割刀(I18)	内径割刀(I19)	小内径割刀(I20)	小内径割刀(I21)	小内径割刀(I21)
TTSIR/L	SNGR/L	MG小径槽刀	A◇SGFTN◇◇	A◇SGFTN◇◇X
内孔端面扣槽刀(I22)	内孔端面扣槽刀(I23)	端面扣槽刀(I24-I25)	端面扣槽刀(I26-I27)	端面扣槽刀(I28-I29)
MFHR/L	NDMR/L-T	MGHH	FGDHX...	FGEHX...
端面扣槽刀(I30-I33)	端面扣槽刀(I34-I35)	端面扣槽刀(I36-I37)	45° 外扣槽刀(I38)	45° 内扣槽刀(I38)
WDMR...	MGFHR/L	STEHR/L	MRWUR/L	MRNUR/L

TTER/L

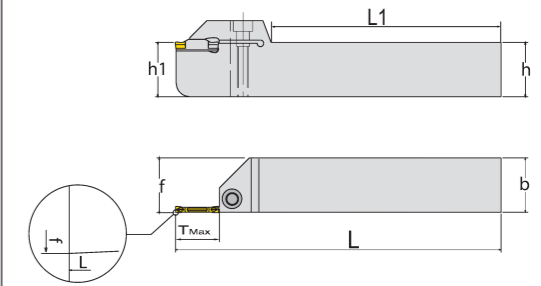

型号 Model	外槽加工, 车削加工 Outside groove processing, turning processing						T _{最大} Max		螺丝NLJ Screw NLJ	扳手 Wrench
	h	b	L	L1	f					
TTER/L	1616 -2	16	16	100	66	16.1	12	TD□□2□□	NLJ0520	L4.0
	2020 -2	20	20	125	91	20.1				
	2525 -2	25	25	150	113	25.1				
	1616 -3	16	16	100	66	16.3	12	TD□□3□□		
	2020 -3	20	20	125	91	20.3				
	2525 -3	25	25	150	113	25.3				
	1616 -4	16	16	100	66	16.5	15	TD□□4□□		
	2020 -4	20	20	125	91	20.5				
	2525 -4	25	25	150	113	25.5				
	2020 -5	20	20	125	86	20.6	20	TD□□5□□		
2525 -5	25	25	150	113	25.6					

TTER/L-T

型号 Model	外槽加工, 车削加工 Outside groove processing, turning processing						T _{最大} Max		螺丝NLJ Screw NLJ	扳手 Wrench
	h	b	L	L1	f					
TTER/L-T	1616 -2T14	16	16	100	66	16.1	14	TD□□2□□	NLJ0520	L4.0
	2020 -2T14	20	20	125	91	20.1				
	2525 -2T14	25	25	150	116	25.1				
	1616 -2T17	16	16	100	63	16.1	17	TD□□2□□		
	2020 -2T17	20	20	125	88	20.1				
	2525 -2T17	25	25	150	113	25.1				
	1616 -3T17	16	16	100	63	16.3	17	TD□□3□□		
	2020 -3T17	20	20	125	88	20.3				
	2525 -3T17	25	25	150	113	25.3				
	1616 -3T20	16	16	100	60	16.3	20	TD□□3□□		
	2020 -3T20	20	20	125	85	20.3				
	2525 -3T20	25	25	150	110	25.3				
	1616 -4T19	16	16	100	61	16.5	19	TD□□4□□		
	2020 -4T19	20	20	125	86	20.5				
	2525 -4T19	25	25	150	111	25.5				
	1616 -4T25	16	16	100	55	16.5	25	TD□□4□□		
	2020 -4T25	20	20	125	80	20.5				
	2525 -4T25	25	25	150	105	25.5				
	2020 -5T25	20	20	125	80	20.6	25	TD□□5□□		
	2525 -5T25	25	25	150	105	25.6				

此款割刀匹配的是特固克的刀片槽

MGEHR/L

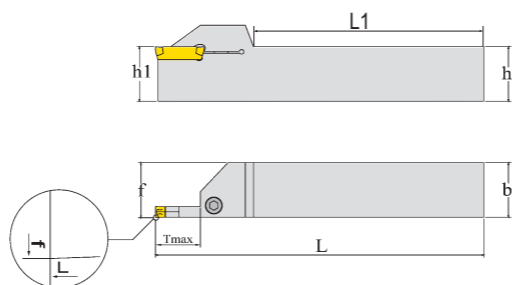



型号 Model		外槽加工, 车削加工 External groove machining, Lathe machining						T _{最大} Max	 螺丝NLJ Screw NLJ	 扳手 Wrench	
		h	b	L	L1	h1	f				
MGEHR/L	1616 H-2	16	16	100	63	16	16.25	14.5	MGMN200	NLJ0520	L4.0
	2020 K-2	20	20	125	90	20	20.25				
	2525 M-2	25	25	150	114	25	25.25				
	3232 P-2	32	32	170	133	32	32.25				
	1616 H-2.5	16	16	100	63	16	16.3				
	2020 K-2.5	20	20	125	88	20	20.3				
	2525 M-2.5	25	25	150	112	25	25.3	16	MGMN250	NLJ0520	L4.0
	3232 P-2.5	32	32	170	130	32	32.3				
	1616 H-3	16	16	100	62	16	16.4				
	2020 K-3	20	20	125	86	20	20.4				
	2525 M-3	25	25	150	110	25	25.4				
	3232 P-3	32	32	170	125	32	32.4				
	1616 H-4	16	16	100	62	16	16.4	18	MGMN300	NLJ0520	L4.0
	2020 K-4	20	20	125	86	20	20.4				
	2525 M-4	25	25	150	110	25	25.4				
	3232 P-4	32	32	170	125	32	32.4				
	1616 H-5	16	16	100	56	16	16.5				
	2020 K-5	20	20	125	80	20	20.5				
	2525 M-5	25	25	150	105	25	25.5	23	MGMN500	NLJ0520	L4.0
	3232 P-5	32	32	170	122	32	32.5				
	2525 M-6	25	25	150	105	25	25.5				
	3232 P-6	32	32	170	122	32	32.5				

MGEHR/L-A

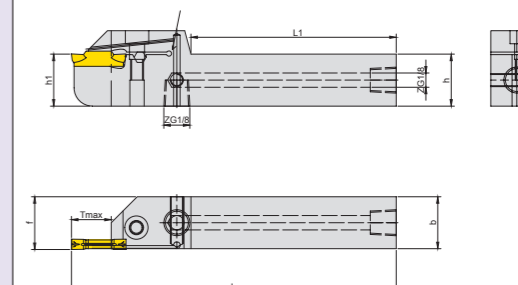
内冷款



型号 Model		外槽加工, 车削加工 External groove machining, Lathe machining						T _{最大} Max	 螺丝NLJ Screw NLJ	 扳手 Wrench
		h	b	L	L1	f	T _{最大} Max			
MGEHR/L	2020 K-2T8-A	20	20	125	84	20.2	8	MGMN200	NLJ0520	L4.0
	2020 K-2T13-A	20	20	125	84	20.2	13			
	2020 K-3T10-A	20	20	125	84	20.32	10			
	2020 K-3T15-A	20	20	125	79	20.32	15			
	2020 K-3T20-A	20	20	125	74	20.32	20			
	2020 K-4T10-A	20	20	125	84	20.3	10			
	2020 K-4T15-A	20	20	125	79	20.3	15	MGMN400	NLJ0520	L4.0
	2020 K-4T20-A	20	20	125	74	20.3	20			
	2020 K-5T10-A	20	20	125	84	20.5	10			
	2020 K-5T15-A	20	20	125	79	20.5	15			
	2020 K-5T20-A	20	20	125	74	20.5	20			
	2525 M-2T8-A	25	25	150	110	25.2	8			
	2525 M-2T13-A	25	25	150	110	25.2	13	MGMN200	NLJ0625	L5.0
	2525 M-3T10-A	25	25	150	110	25.33	10			
	2525 M-3T15-A	25	25	150	110	25.33	15			
	2525 M-3T20-A	25	25	150	105	25.33	20			
	2525 M-4T10-A	25	25	150	110	25.33	10			
	2525 M-4T15-A	25	25	150	110	25.33	15			
	2525 M-4T20-A	25	25	150	105	25.33	20	MGMN300	NLJ0625	L5.0
	2525 M-5T10-A	25	25	150	110	25.5	10			
	2525 M-5T15-A	25	25	150	110	25.5	15			
	2525 M-5T20-A	25	25	150	105	25.5	20			

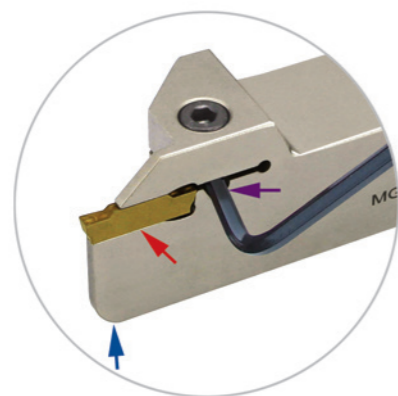

- ▶ 此款割刀匹配的是克洛依的刀片槽
- ▶ 优化的圆弧型设计, 减少了震动源
- ▶ 为满足不同客户的使用要求, 本公司特别设计了此款割刀扳手, 此款割刀原配克洛依标准刀片, 因国内厂家生产刀片外形公差尺寸不同, 造成刀片放不进或压不紧。本款刀具双重压紧方式, 使刀片与刀体接触的更好, 有效的提升刀片与刀体的使用寿命。



此款割刀匹配的是悍狮霸、克洛依的刀片槽

MGEHR/L-T

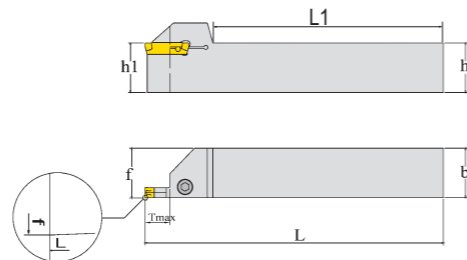

型号 Model	外槽加工, 车削加工 External groove machining, Lathe machining								螺丝NLJ Screw NLJ	扳手 Wrench
	h	b	L	L1	h1	f	T _{最大} Max			
1616 H-1.5T6	16	16	100	63	16	16.2	6	MGMN150	NLJ0520	L4.0
1616 H-1.5T8	16	16	100	63	16	16.2	8			
1616 H-1.5T10	16	16	100	63	16	16.2	10			
1616 H-1.5T12	16	16	100	63	16	16.2	12			
2020 K-1.5T6	20	20	125	90	20	20.2	6			
2020 K-1.5T8	20	20	125	90	20	20.2	8			
2020 K-1.5T10	20	20	125	90	20	20.2	10			
2020 K-1.5T12	20	20	125	90	20	20.2	12			
1616 H-2T10	16	16	100	63	16	16.25	10			
2020 K-2T10	20	20	125	90	20	20.25	10			
2525 M-2T10	25	25	150	114	25	25.25	10			
3232 P-2T10	32	32	170	133	32	32.25	10			
1616 H-2.5T10	16	16	100	63	16	16.3	10			
2020 K-2.5T10	20	20	125	88	20	20.3	10			
2525 M-2.5T10	25	25	150	112	25	25.3	10			
3232 P-2.5T10	32	32	170	130	32	32.3	10			
1616 H-3T10	16	16	100	62	16	16.4	10			
2020 K-3T10	20	20	125	86	20	20.4	10			
2020 K-3T25	20	20	125	79	20	20.4	25			
2020 K-3T30	20	20	125	74	20	20.4	30			
2020 K-3T35	20	20	125	69	20	20.4	35			
2020 K-3T40	20	20	125	64	20	20.4	40			
2525 M-3T10	25	25	150	111	25	25.4	10			
2525 M-3T25	25	25	150	104	25	25.4	25			
2525 M-3T30	25	25	150	99	25	25.4	30			
2525 M-3T35	25	25	150	125	32	25.4	35			
2525 M-3T40	25	25	150	94	25	25.4	40			
2525 M-3T50	25	25	150	89	25	25.4	50			
3232 P-3T10	32	32	170	79	25	32.4	10			
1616 H-4T10	16	16	100	62	16	16.4	10			
2020 K-4T10	20	20	125	86	20	20.4	10			
2020 K-4T25	20	20	125	79	20	20.4	25			
2020 K-4T30	20	20	125	74	20	20.4	30			
2020 K-4T35	20	20	125	69	20	20.4	35			
2020 K-4T40	20	20	125	64	20	20.4	40			
2525 M-4T10	25	25	150	111	25	25.4	10			
2525 M-4T25	25	25	150	104	25	25.4	25			
2525 M-4T30	25	25	150	99	25	25.4	30			
2525 M-4T35	25	25	150	94	25	25.4	35			
2525 M-4T40	25	25	150	89	25	25.4	40			
2525 M-4T50	25	25	150	79	25	25.4	50			
3232 P-4T10	32	32	170	125	32	32.4	10			
3232 P-4T30	32	32	170	105	32	32.4	30			
3232 P-4T35	32	32	170	100	32	32.4	35			
3232 P-4T40	32	32	170	90	32	32.4	40			
3232 P-4T50	32	32	170	80	32	32.4	50			
1616 H-5T10	16	16	100	56	16	16.5	10			
2020 K-5T10	20	20	125	80	20	20.5	10			
2525 M-5T10	25	25	150	105	25	25.5	10			
2525 M-5T30	25	25	150	99	25	25.4	30			
2525 M-5T35	25	25	150	94	25	25.4	35			
2525 M-5T40	25	25	150	89	25	25.4	40			

型号 Model	外槽加工, 车削加工 External groove machining, Lathe machining								螺丝NLJ Screw NLJ	扳手 Wrench
	h	b	L	L1	h1	f	T _{最大} Max			
2525 M-5T50	25	25	150	79	25	25.4	50	MGMN500	NLJ0620	L5.0
3232 P-5T10	32	32	170	122	32	32.5	10			
3232 P-5T30	32	32	170	105	32	32.4	30			
3232 P-5T35	32	32	170	100	32	32.4	35			
3232 P-5T40	32	32	170	90	32	32.4	40			
3232 P-5T50	32	32	170	80	32	32.4	50			
1616H-1.5R10	16	16	100	63	16	16.2	10	MGMN150		
1616H-1.5R13	16	16	100	63	16	16.2	13			
2020K-1.5R10	20	20	125	90	20	20.2	10			
2020K-1.5R13	20	20	125	90	20	20.2	13			
2020K-1.5R16	20	20	125	88	20	20.2	16			
2020K-3R25	20	20	125	79	20	20.4	25	MGMN300	NLJ0520	L4.0
2020K-3R30	20	20	125	74	20	20.4	30			
2525M-3R25	25	25	150	104	25	25.4	25			
2525M-3R30	25	25	150	99	25	25.4	30			
2020K-4R25	20	20	125	79	20	20.4	25	MGMN400		
2020K-4R30	20	20	125	74	20	20.4	30			
2525M-4R25	25	25	150	104	25	25.4	25			
2525M-4R30	25	25	150	99	25	25.4	30			
2525M-4R35	25	25	150	94	25	25.4	35			
3232P-6T30	32	32	170	105	32	32.4	30	MGMN600	NLJ0620	L5.0
3232P-6T35	32	32	170	100	32	32.4	35			
3232P-6T40	32	32	170	90	32	32.4	40			
3232P-6T50	32	32	170	80	32	32.4	50			

KGMR/L

KGMR/L-T

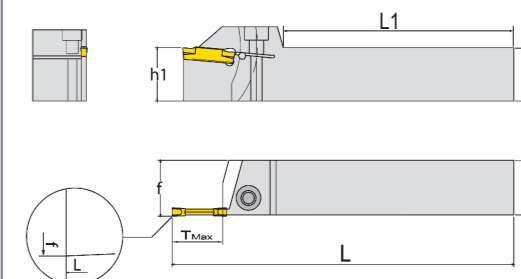
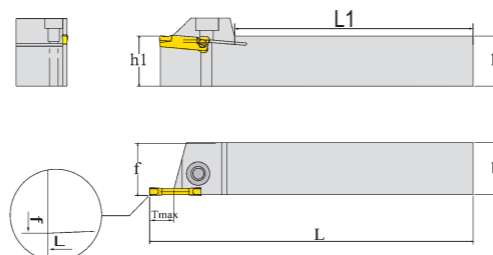

型号 Model		外槽加工, 车削加工 Outside groove processing, turning processing						刀片 Insert	螺丝NLJ Screw NLJ	扳手 Wrench
		h	b	L	L1	f	T _{最大} Max			
KGMR/L	1616 H-1.5	16	16	100	70	16.25	GMM1520...MT GMM2020...MT	NLJ0520	L4.0	
	2020 K-1.5	20	20	125	93	20.25				
	2525 M-1.5	25	25	150	120	25.25				
	1616 H-2	16	16	100	70	16.25				
	2020 K-2	20	20	125	93	20.25				
	2525 M-2	25	25	150	120	25.25	GMG2020...MS GMM2520...MS			
	1616 H-2.5	16	16	100	70	16.3				
	2020 K-2.5	20	20	125	93	20.3				
	2525 M-2.5	25	25	150	120	25.3				
	1616 H-3	16	16	100	70	16.35				
	2020 K-3	20	20	125	93	20.35	GMG3020...MS GMM3020...MS GMG4020...MS GMM4020...MS			
	2525 M-3	25	25	150	120	25.35				
	1616 H-4	16	16	100	70	16.35				
	2020 K-4	20	20	125	93	20.35				
	2525 M-4	25	25	150	120	25.35				
2020 K-5	20	20	125	93	20.4	GMG5020...MS GMM5020...MS GMG6020...MS GMM6020...MS				
2525 M-5	25	25	150	120	25.4					

型号 Model		外槽加工, 车削加工 External groove machining, Lathe machining						刀片 Insert	螺丝NLJ Screw NLJ	扳手 Wrench
		h	b	L	L1	f	h1			
KGMR/L	1212 K-1.5-T17	12	12	125	90	12.15	GMG1520...MS GMM2020...MS	NLJ0417	L3.0	
	1616 H-1.5-T17	16	16	100	65	16.15				
	2020 K-1.5-T17	20	20	125	90	20.15				
	2525 M-1.5-T17	25	25	150	113	25.15				
	1212 K-2-T17	12	12	125	90	12.25				
	1616 H-2-T17	16	16	100	65	16.25	GMG2020...MS GMM2520...MS			
	2020 K-2-T17	20	20	125	90	20.25				
	2525 M-2-T17	25	25	150	113	25.25				
	1212 K-2.5-T17	12	12	125	90	12.3				
	1616 H-2.5-T17	16	16	100	65	16.3				
	2020 K-2.5-T17	20	20	125	90	20.3	GMG2520...MS GMM3020...MS			
	2525 M-2.5-T17	25	25	150	113	25.3				
	1212 K-3-T20	12	12	125	87	12.35				
	1616 H-3-T20	16	16	100	62	16.35				
	2020 K-3-T20	20	20	125	87	20.35				
	2525 M-3-T20	25	25	150	110	25.35	GMG3020...MS GMM3020...MS GMG4020...MS GMM4020...MS			
	1616 H-4-T20	16	16	100	62	16.35				
	2020 K-4-T20	20	20	125	87	20.35				
	2525 M-4-T20	25	25	150	110	25.35				
	1616 H-5-T25	16	16	100	57	16.4				GMG4020...MS GMM4020...MS GMG5020...MS GMM5020...MS
	2020 K-5-T25	20	20	125	82	20.4				
	2525 M-5-T25	25	25	150	105	25.4				

此款割刀匹配的是京瓷的刀片槽

此款割刀匹配的是京瓷的刀片槽

QE□DR/L

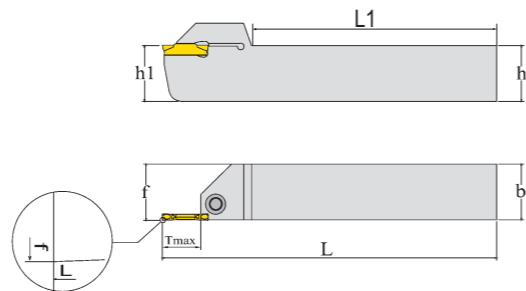

型号 Model		外槽加工, 车削加工 Outside groove processing, turning processing						刀片 Insert	螺丝NLJ Screw NLJ	扳手 Wrench						
		h	b	L	L1	f	T _{最大} Max									
QEBD	1616 R/L10	16	16	100	67	16.18	10	Z□BD02□□	NLJ0520	L4.0						
	1616 R/L17	16	16	100	60	16.18	17									
	2020 R/L10	20	20	125	92	20.18	10									
	2020 R/L17	20	20	125	85	20.18	17									
	2525 R/L10	25	25	150	117	25.18	10									
2525 R/L17	25	25	150	110	25.18	17										
QEED	1616 R/L10	16	16	100	64	16.25	10				Z□ED025□□	NLJ0520	L4.0			
	1616 R/L17	16	16	100	60	16.25	17									
	2020 R/L10	20	20	125	89	20.25	10									
	2020 R/L17	20	20	125	85	20.25	17									
	2525 R/L10	25	25	150	114	25.25	10									
2525 R/L17	25	25	150	110	25.25	17										
QEFD	1616 R/L10	16	16	100	64	16.3	10							Z□FD03□□	NLJ0520	L4.0
	1616 R/L17	16	16	100	60	16.3	17									
	2020 R/L10	20	20	125	89	20.3	10									
	2020 R/L17	20	20	125	85	20.3	17									
	2525 R/L10	25	25	150	114	25.3	10									
2525 R/L17	25	25	150	110	25.3	17										
QEGD	1616 R/L13	16	16	100	61	16.5	13	Z□GD04□□	NLJ0625	L5.0						
	1616 R/L22	16	16	100	55	16.5	22									
	2020 R/L13	20	20	125	86	20.5	13									
	2020 R/L22	20	20	125	80	20.5	22									
	2525 R/L13	25	25	150	111	25.5	13									
2525 R/L22	25	25	150	105	25.5	22										
QEHD	3232 R/L13	32	32	170	131	32.5	13				Z□HD05□□	NLJ0520	L4.0			
	3232 R/L22	32	32	170	125	32.5	22									
	2525 R/L13	25	25	150	111	25.5	13									
	2525 R/L22	25	25	150	105	25.5	22									
	3232 R/L13	32	32	170	131	32.5	13									
3232 R/L22	32	32	170	125	32.5	22										
QEKD	2525 R/L13	25	25	150	111	25.6	13							Z□KD06□□	NLJ0520	L4.0
	2525 R/L22	25	25	150	105	25.6	22									
	3232 R/L13	32	32	170	131	32.6	13									
3232 R/L22	32	32	170	125	32.6	22		NLJ0625	L5.0							



此款割刀匹配的是株硬的刀片槽

GHDR/L

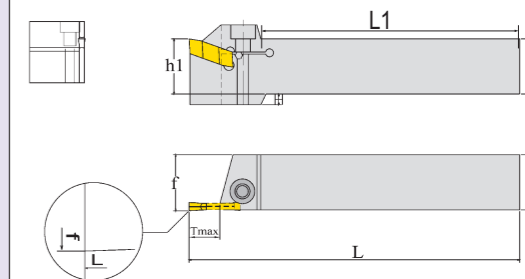

型号 Model		外槽加工, 车削加工 Outside groove processing, turning processing							刀片 Insert	螺丝NLJ Screw NLJ	扳手 Wrench
		h	b	L	L1	f	H	T _{最大} Max			
GHDR/L	1616H-3	16	16	100	70	16.35	4	11	GIP GIF GIPV GIPA GIA GITM	NLJ0520	L4.0
	2020K-3	20	20	125	95	20.35	⊗				
	2525M-3	25	25	150	120	25.35	⊗				
	1616H-4	16	16	100	70	16.35	4				
	2020K-4	20	20	125	95	20.35	⊗				
	2525M-4	25	25	150	120	25.35	⊗				
	1616H-5	16	16	100	70	16.4	4				
	2020K-5	20	20	125	95	20.4	⊗				
2525M-5	25	25	150	120	25.4	⊗					

GHGR/L

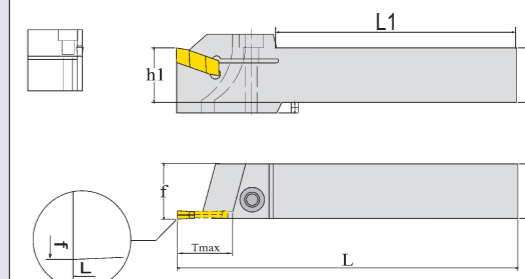

型号 Model		外槽加工, 车削加工 Outside groove processing, turning processing							刀片 Insert	螺丝NLJ Screw NLJ	扳手 Wrench
		h	b	L	L1	f	H	T _{最大} Max			
GHGR/L	1616H-3	16	16	100	63	16.35	4	20	GIP GIF GIPV GIPA GIA GITM	NLJ0520	L4.0
	2020K-3	20	20	125	88	20.35	⊗				
	2525M-3	25	25	150	113	25.35	⊗				
	1616H-4	16	16	100	63	16.35	4				
	2020K-4	20	20	125	88	20.35	⊗				
	2525M-4	25	25	150	113	25.35	⊗				
	1616H-5	16	16	100	58	16.35	4				
	2020K-5	20	20	125	83	20.4	⊗				
2525M-5	25	25	150	108	25.4	⊗					
							25				



此款割刀匹配的是依斯卡的刀片槽

MGEVR/L

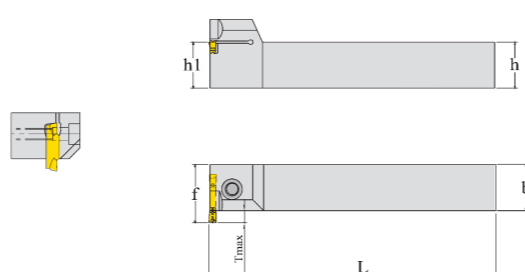

型号 Model		外槽加工, 车削加工 External groove machining, Lathe machining					刀片 Insert	螺丝NLJ Screw NLJ	扳手 Wrench
		h	b	L	f	T _{最大} Max			
MGEVR/L	2020 -2	20	20	125	23.5	3.5	MGMN200	NLJ0520	L4.0
	2525 -2	25	25	150	28.5				
	3232 -2	32	32	170	35.5				
	2020 -2.5	20	20	125	24	4	MGMN250		
	2525 -2.5	25	25	150	29				
	3232 -2.5	32	32	170	36				
	2020 -3	20	20	125	25.5	5	MGMN300		
	2525 -3	25	25	150	30.5				
	3232 -3	32	32	170	37.5				
	2020 -4	20	20	125	25.5	MGMN400			
	2525 -4	25	25	150	30.5				
	3232 -4	32	32	170	37.5				
	2020 -5	20	20	125	27	7	MGMN500		
	2525 -5	25	25	150	32				
	3232 -5	32	32	170	39				

MGEVR/L-T

新品

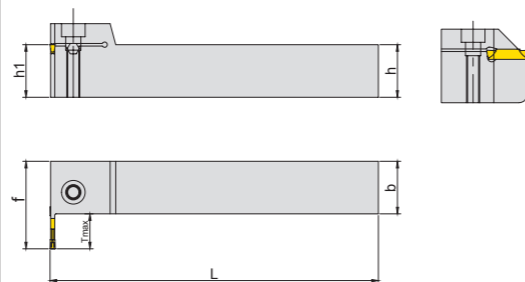

型号 Model		外槽加工, 车削加工 External groove machining, Lathe machining						刀片 Insert	螺丝NLJ Screw NLJ	扳手 Wrench
		h	b	L	L1	f	T _{最大} Max			
MGEVR/L	2020 K-1.5-T7	20	20	125	100	27.3	7	MGMN150	NLJ0520	L4.0
	2020 K-2-T7	20	20	125	100	27.3	7			
	2020 K-2-T13	20	20	125	100	33.3	13			
	2020 K-2.5-T7	20	20	125	100	27.3	7	MGMN250		
	2020 K-2.5-T13T	20	20	125	100	33.3	13			
	2020 K-3-8T	20	20	125	100	28.3	8			
	2020 K-3-15T	20	20	125	100	35.3	15	MGMN300		
	2020 K-4-8T	20	20	125	100	28.3	8			
	2020 K-4-15T	20	20	125	100	35.5	15			

MGWHR/L

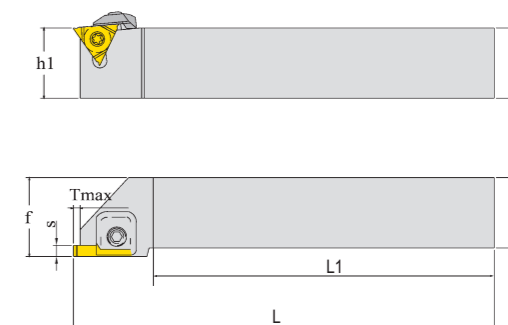

型号 Model		外槽加工, 车削加工 External groove machining, Lathe machining								刀片 Insert	压板MYB Pressing plate MYB	弹簧TH Spring TH	螺丝NLJ Screw NLJ	扳手 Wrench
		h	b	L	L1	S	T _{最大} Max	H1	f					
MGWHR/L	1616 H4300	16	16	100	72	1.45	1.5	16	20	MG◇◇43◇◇	MYB1318	TH1814	MGT0620-P	L4.0
	1616 H4315	16	16	100	72	1.5-2.3	3.0	16	20					
	1616 H4323	16	16	100	72	2.3-3.3	3.0	16	20					
	1616 H4333	16	16	100	72	3.3-4.7	3.0	16	20					
	2020 K4300	20	20	125	95	1.45	1.5	20	25					
	2020 K4315	20	20	125	95	1.5-2.3	3.0	20	25					
	2020 K4323	20	20	125	95	2.3-3.3	3.0	20	25					
	2020 K4333	20	20	125	95	3.3-4.7	3.0	20	25					
	2525 M4300	25	25	150	120	1.45	1.5	25	32					
	2525 M4315	25	25	150	120	1.5-2.3	3.0	25	32					
	2525 M4323	25	25	150	120	2.3-3.3	3.0	25	32					
	2525 M4333	25	25	150	120	3.3-4.7	3.0	25	32					

SVNR 小径镗孔刀(方刀)

新品

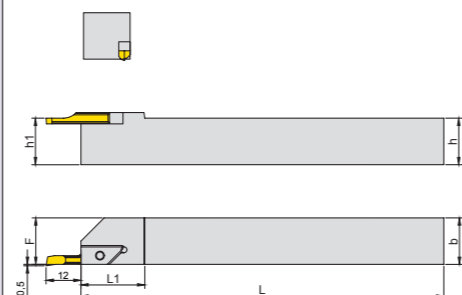

型号 Model		h	b	L	L1	h1	F	螺丝 Screw	扳手 Wrench
SVNR-1212K-12N	12	12	125	22	12	12			
SVNR-1616K-12N	16	16	125	22	16	16			
SVNR-2020K-12N	20	20	125	22	20	20			
SVNR-2525M-12N	25	25	150	22	25	25			

SGEL

新品

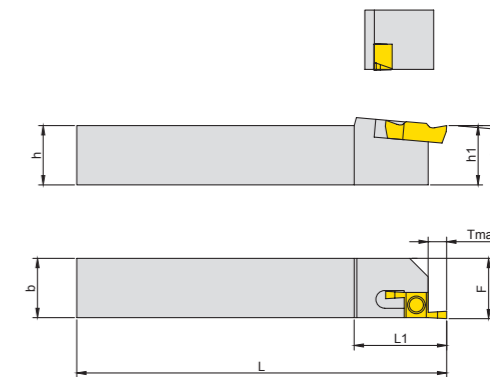

型号 Model	适用条件 Applicable conditions							螺丝NLJ Screw NLJ	扳手 Wrench
	h	b	L	L1	F	T _{max}			
SGEL 1616H-06	16	16	100	25	16.3	5	GE R/L200	M3	T-10
SGEL 2020K-06	20	20	125	25	20.3	5			
SGEL 2525M-06	25	25	150	25	25.3	5			

S-SVNR 小径镗孔刀

新品

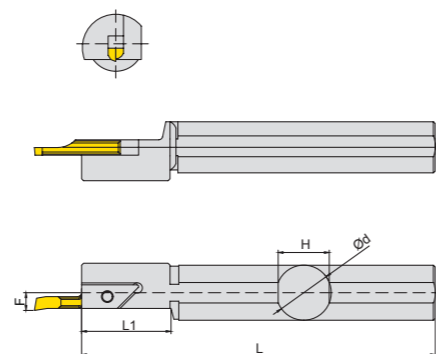

型号 Model		ød	L	L1	H	螺丝 Screw	扳手 Wrench
S12F-SVNR12N	12	80	23	11			
S14G-SVNR12N	14	90	23	13			
S16H-SVNR12N	16	100	23	15			
S18H-SVNR12N	18	100	24	18			
S20H-SVNR12N	20	100	24	18			

B-SGEL

新品

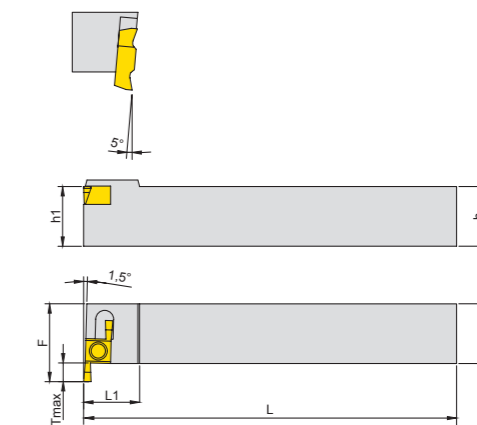

型号 Model	适用条件 Applicable conditions							螺丝NLJ Screw NLJ	扳手 Wrench
	h	b	L	L1	F	T _{max}			
B-SGER 1616H-06	16	16	100	15	20.86	5	GE R/L200	M3	T-10
B-SGER 2020K-06	20	20	125	15	24.86	5			
B-SGER 2525M-06	25	25	150	15	29.86	5			

MGENN

新品

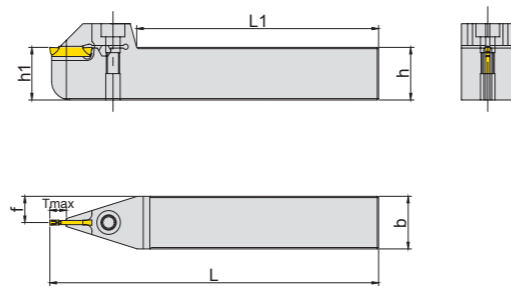

型号 Model		外槽加工, 车削加工 External groove machining, Lathe machining						刀片 Insert	螺丝NLJ Screw NLJ	扳手 Wrench
		h	b	L	L1	f	T _{最大} Max			
MGENN	2020 K-2T6	20	20	125	87	10	6	MGMN200	NLJ0520	L4.0
	2020 K-2.5T7	20	20	125	87	10	7			
	2020 K-3T7	20	20	125	87	10	7			
	2020 K-4T7	20	20	125	87	10	7			
	2020 K-5T8	20	20	125	82	10	8	MGMN500	NLJ0625	L5.0
	2525 M-3T7	25	25	150	105	12.5	7			
	2525 M-4T7	25	25	150	105	12.5	7			
	2525 M-5T8	25	25	150	105	12.5	8			
	2525 M-6T10	25	25	150	105	12.5	10			

MGNVR/L-A

内冷款

新品

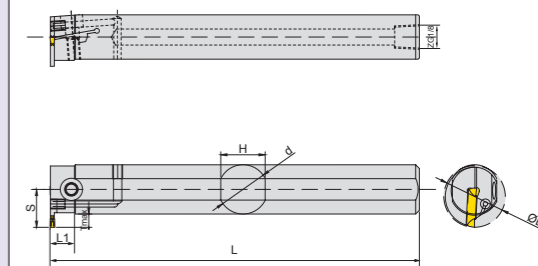

型号 Model		内槽加工, 车削加工 Inside groove machining, Lathe machining							刀片 Insert	螺丝NLJ Screw NLJ	扳手 Wrench	
		φD	d	L	L1	H	T _{最大} Max	S				
MGNVR/L	1620M-2-T3-A	20	16	150	10	15	3	11.4	MGMN200	DGD0416	L3	
	1622M-2-T5-A	22	16	150	10	15	5	13.4				
	1624M-2-T7-A	24	16	150	10	15	7	15.4				
	1626M-2-T5-A	26	20	150	10	18	5	15.4				
	1628M-2-T7-A	28	20	150	10	18	7	17.4				
	1630M-2-T9-A	30	20	150	10	18	9	19.4				
	1622M-2.5-T5-A	22	16	150	10	15	5	13.4		MGMN250	DGD0416	L3
	1624M-2.5-T7-A	24	16	150	10	15	7	15.4				
	1626M-2.5-T9-A	26	16	150	10	15	9	17.4				
	2027M-2.5-T8-A	26	20	150	10	18	6	16.4				
	2029M-2.5-T8-A	29	20	150	10	18	8	18.4				
	2031M-2.5-T10-A	34	20	150	10	18	10	20.4				
	1622M-3-T5-A	22	16	150	10	15	5	13.4	MGMN300		DGD0416	L3
	1624M-3-T7-A	24	16	150	10	15	7	15.4				
	1626M-3-T5-A	26	16	150	10	15	9	17.4				
	2027M-3-T6-A	27	20	150	10	18	6	16.4				
	2029M-3-T8-A	29	20	150	10	18	8	18.4				
	2031M-3-T6-A	31	20	150	10	18	10	20.4				
	2532R-3-T6-A	32	25	200	10	23	6	18.9		MGMN400	DGD0520	L4
	2534R-3-T8-A	34	25	200	10	23	8	20.9				
	2536R-3-T10-A	36	25	200	10	23	10	22.9				
	2538R-3-T12-A	38	25	200	10	23	12	24.9				
	3239S-3-T6-A	39	32	250	10	29	6	22.4				
	3241S-3-T8-A	41	32	250	10	29	8	24.4				
	3243S-3-T10-A	43	32	250	10	29	10	26.4				
	3245S-3-T12-A	45	32	250	10	29	12	28.4				
	2532R-4-T6-A	32	25	200	10	23	6	18.9	MGMN500		DGD0520	L4
	2534R-4-T8-A	34	25	200	10	23	8	20.9				
	2536R-4-T10-A	36	25	200	10	23	10	22.9				
	2538R-4-T12-A	38	25	200	10	23	12	24.9				
	3239S-4-T6-A	39	32	250	10	29	6	22.4				
	3241S-4-T8-A	41	32	250	10	29	8	24.4				
	3243S-4-T10-A	43	32	250	10	29	10	26.4				
	3245S-4-T12-A	45	32	250	10	29	12	28.4				
	2532R-5-T6-A	32	25	200	10	23	6	18.9		MGMN500	DGD0520	L4
	2534R-5-T8-A	34	25	200	10	23	8	20.9				
	2536R-5-T10-A	36	25	200	10	23	10	22.9				
	2538R-5-T12-A	38	25	200	10	23	12	24.9				
	3241S-5-T8-A	41	32	250	10	29	8	24.4				
	3243S-5-T10-A	43	32	250	10	29	10	26.4				
	3245S-5-T12-A	45	32	250	10	29	12	28.4				
	3249S-5-T16-A	48	32	250	10	29	16	32.4				

MGNVR/L

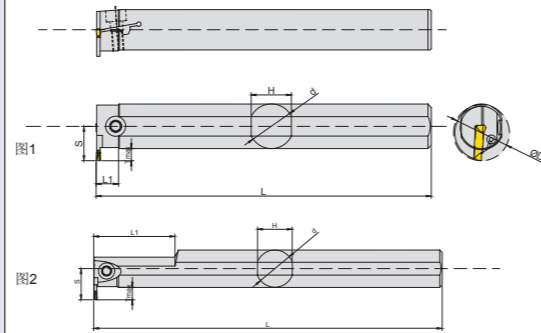

型号 Model	内槽加工, 车削加工 Inside groove machining, Lathe machining								形状	螺丝NLJ Screw NLJ	扳手 Wrench
	∅D	d	L	L1	H	T _{最大} Max	S				
1617M-1.5-T3	17	16	150	35	15	3	11.4	图2	MGMN150	DGD0416	L3
1618M-1.5-T4	18	16	150	35	15	4	12.4	图2			
1619M-1.5-T5	19	16	150	35	15	5	13.4	图2			
1620M-1.5-T6	20	16	150	35	15	6	14.4	图2			
1615M-2-T3	15	16	150	30	15	3	11.4	图2			
1616M-2-T4	16	16	150	30	15	4	12.4	图2			
1617M-2-T5	17	16	150	30	15	5	13.4	图2			
1618M-2-T4	18	16	150	35	15	4	12.4	图2			
1619M-2-T5	19	16	150	35	15	5	13.4	图2			
1620M-2-T3	20	16	150	10	15	3	11.4	图1			
1620M-2-T6	20	16	150	35	15	6	14.4	图2			
1622M-2-T5	21	16	150	10	15	5	13.4	图1			
1624M-2-T7	24	16	150	10	15	7	15.4	图1			
2025M-2-T5	25	20	150	10	18	5	15.4	图1			
2025M-2-T7	25	20	150	45	18	7	17.4	图2			
2025M-2-T9	25	20	150	40	18	7	19.4	图2			
1617M-3-T3	17	16	150	35	15	3	11.4	图2			
1618M-3-T4	18	16	150	35	15	4	12.4	图2			
1619M-3-T5	19	16	150	35	15	5	13.4	图2			
1620M-3-T6	20	16	150	35	15	6	14.4	图2			
1624M-3-T7	24	16	150	10	15	7	15.4	图1			
1626M-3-T9	26	16	150	10	15	9	17.4	图1			
2027M-3-T6	27	20	150	10	18	6	16.4	图1			
2029M-3-T8	29	20	150	10	18	8	18.4	图1			
2031M-3-T10	31	20	150	10	18	10	20.4	图1			
2532R-3-T6	32	25	200	10	23	5	18.4	图1			
2534R-3-T8	34	25	200	10	23	8	20.9	图1			
2536R-3-T10	35	25	200	10	23	10	22.9	图1			
2538R-3-T12	38	25	200	10	23	12	24.9	图1			
3239S-3-T6	39	32	250	10	29	6	22.4	图1			
3241S-3-T8	41	32	250	10	29	8	24.4	图1			
3243S-3-T10	43	32	250	10	29	10	26.4	图1			
3245S-3-T12	45	32	250	10	29	12	28.4	图1			
2027M-4-T6	27	20	150	10	18	6	16.4	图1			
2029M-4-T8	29	20	150	10	18	8	18.4	图1			
2031M-4-T10	31	20	150	10	18	10	20.4	图1			
2532R-4-T6	32	25	200	10	23	6	18.9	图1			
2534R-4-T8	34	25	200	10	23	8	20.9	图1			
2536R-4-T10	36	25	200	10	23	10	22.9	图1			

型号 Model	内槽加工, 车削加工 Inside groove machining, Lathe machining								形状	螺丝NLJ Screw NLJ	扳手 Wrench	
	∅D	d	L	L1	H	T _{最大} Max	S					
MGNVR/L	2538R-4-T12	38	25	200	10	23	12	24.9	图1	MGMN400	DGD0520	L4
	3239S-4-T6	39	32	250	10	29	6	22.4	图1			
	3241S-4-T8	41	32	250	10	29	8	24.4	图1			
	3243S-4-T10	43	32	250	10	29	10	26.4	图1			
	3245S-4-T12	45	32	250	10	29	12	28.4	图1			
	2532R-5-T6	32	25	200	10	23	6	18.9	图1			
	2534R-5-T8	34	25	200	10	23	8	20.9	图1			
	2536R-5-T10	36	25	200	10	23	10	22.9	图1			
	2538R-5-T12	38	25	200	10	23	12	24.9	图1			
	3241S-5-T8	41	32	250	10	29	8	24.4	图1			
	3243S-5-T10	43	32	250	10	29	10	26.4	图1			
	3245S-5-T12	45	32	250	10	29	12	28.4	图1			



此款割刀匹配的是悍狮霸、克洛伊的刀片槽

KIGMR/L

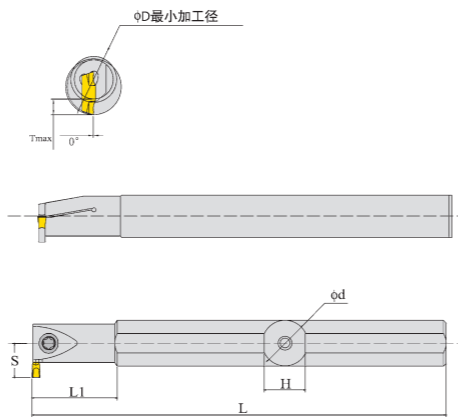

型号 Model	内槽加工, 车削加工 Inside groove machining, Lathe machining							螺丝NLJ Screw NLJ	扳手 Wrench	
	φD	d	L	L1	H	T _{最大} Max	S			
KIGMR/L	1716B-3V	17	16	150	30	15	5	9.6	GMM3015	DGD0416 L4.0
	2016B-3V	20	16	150	30	15	5	12.4		
	2520B-3V	25	20	180	35	18	5	14.5		
	3225B-3V	32	25	200	45	23	6	19		
	3225B-4V	32	25	200	45	23	6	19		
									GMM4020	

TTSIR/L

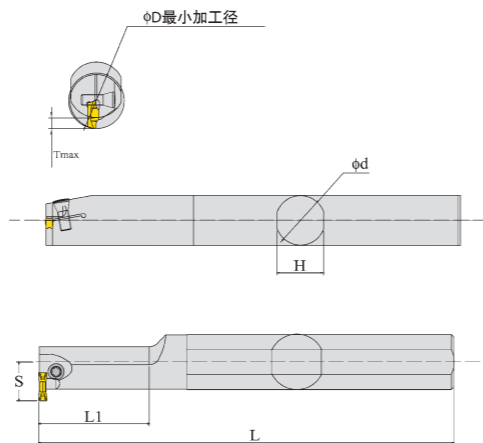

型号 Model	内槽加工, 车削加工 Inside groove machining, Lathe machining							螺丝NLJ Screw NLJ	扳手 Wrench			
	D _{最小加工径} Minimal processing	d	L	L1	H	T _{最大} Max	S					
TTSIR/L	16-12.5-2	12.5	16	150	20	15	2.5	10.5	TDIM 2E TDIP 2E	M4-10 T15		
	16-12.5-2T3.5	12.5	16	150	20	15	3.5	11.4				
	16-14-2	14	16	150	25	15	3	11				
	16-14-2T4	14	16	150	25	15	4	12				
	16-16-2	16	16	150	40	15	4	12				
	16-12.5-3	12.5	16	150	20	15	2.5	10.5			TDIM 3E TDIP 3E	M4-10 T15
	16-14-3	14	16	150	25	15	3	11				
	16-16-3	16	16	150	40	15	4	12				
	20-20-3	20	20	150	40	18	4	14				

此款割刀匹配的是特固克的刀片槽

SNGR/L

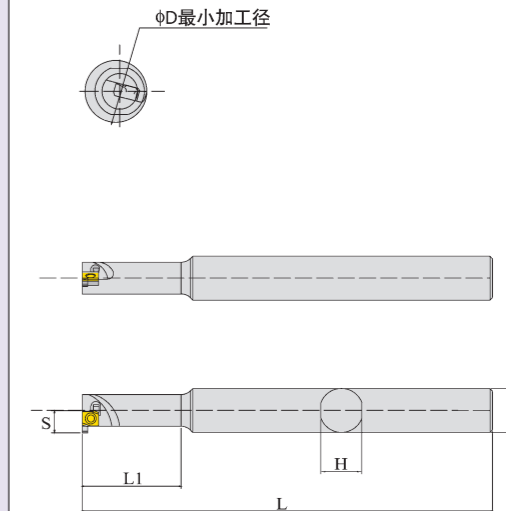

型号 Model	内槽加工, 车削加工 Inside groove machining, Lathe machining							螺丝 Screw	扳手 Wrench	
	D _{最小加工径} Minimal processing	d	L	L1	H	T _{最大} Max	S			
SNGR/L	0008 H07	10	8	100	45	7	1.5	5.8	7GR/L	M2.5*11 T-8
	0812 H07	10	12	100	45	11	1.5	5.8		
	1012 K07	12	12	125	45	11	1.5	6.8		
	0816 H07	10	16	100	45	15	1.5	5.8		
	1016 K07	12	16	125	65	15	1.5	6.8		
	0010 K08	12.5	10	125	45	9	2	7.3	8GR/L	
	1012 K08	12.5	12	125	45	11	2	7.3		
	0012 M08	14	12	150	65	11	2	8.1		
	1016 K08	12.5	16	125	45	15	2	7.3		
	1216 M08	14	16	150	65	15	2	8.1		
	1416 N08	14	16	160	45	15	2	9.1	9GR/L	
	0016 Q09	17	16	180	65	15	3.5	11.2		
	0020 R09	18	20	200	65	18	3.5	11.2		



此款割刀匹配的是东芝的刀片槽

MG小径槽刀

新品

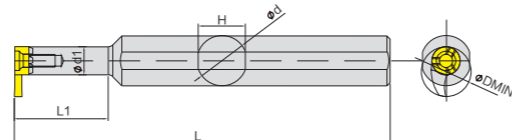
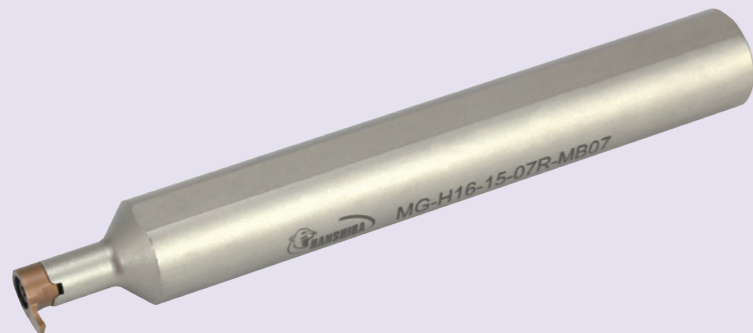

型号 Model		φD	φd	φd1	H	L	L1	螺丝 Screw	扳手 Wrench					
MG-H12-10-05R-MB05	MB-05GR100-2.8D09	9	12	5	11	100	10	LD30252270 T6-50	T-6					
MG-H12-16-05R-MB05	MB-05GR150-2.8D09	9	12	5	11	100	16							
MG-H12-15-07R-MB07	MB-07GR100-3.5D12	12	12	7	11	100	15							
MG-H12-20-07R-MB07	MB-07GR150-3.5D12	12	12	7	11	100	20	LD40303090 T8-60	T-8					
MG-H16-15-07R-MB07	MB-07GR200-3.5D12	12								16	7	15	120	15
MG-H16-20-07R-MB07	MB-07GR300-3.0D11	11	16	7	15	120	20							
MG-H16-20-09R-MB09	MB-09GR100-5.5D16	16	16	9	15	120	20	LD57284010 T15-60	T-15					
MG-H16-25-09R-MB09	MB-09GR150-6.5D17	17								16	9	15	120	25
MG-H16-30-09R-MB09	MB-09GR250-5.5D16	16								16	9	15	120	30

A◇◇SGFTN◇◇

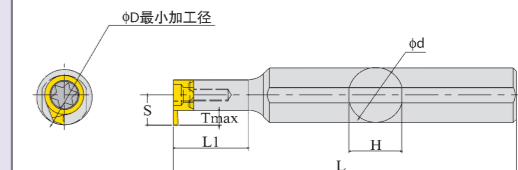

型号(老款) Model	φD	d	L	L1	H	T _{最大} Max	S	切槽 grooving	螺纹 screw	成行 rows	螺丝 Screw	扳手 Wrench
A12G	8	12	90	20	11	1.8	4.8	FTG	FTT	FTF	M2.5*8	T8
	11	12	90	20	11	2.6	6.7				M3*10	T8
A12H	14	12	100	25	11	4.0	9				M4*10	T15
A16H	16	12	100	25	11	4.5	10.2				M5*12	T20
		14	16	100	25	15	4.0				9	M4*10
	16	16	100	25	15	4.5	10.2				M5*12	T20

A◇◇SGFTN◇◇X

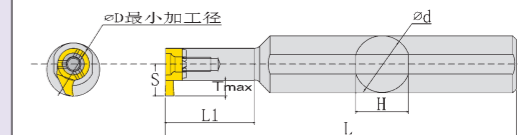

型号(新款) Model	φD	d	L	L1	H	T _{最大} Max	S	切槽 grooving	螺纹 screw	成行 rows	螺丝 Screw	扳手 Wrench
A12G	8	12	90	20	11	1.8	4.8	FTG	FTT	FTF	M2.5*8	T8
	11	12	90	20	11	2.6	6.7				M3*10	T8
A12H	14	12	100	25	11	4.0	9				M4*10	T15
A16H	16	12	100	25	11	4.5	10.2				M5*12	T20
		14	16	100	25	15	4.0				9	M4*10
	16	16	100	25	15	4.5	10.2				M5*12	T20

此款割刀匹配的是克洛依的刀片槽

MFHR/L

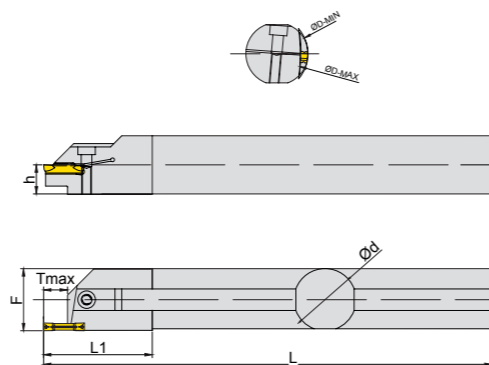

型号 Model	内槽加工, 车削加工 Inside groove machining, Lathe machining								螺母NLJ Screw NLJ	扳手 Wrench
	h	∅d	L	L1	F	T _{max}	最小	最大		
MFH216Q06-25-140	7.5	16	180	48	6	6	25	140	MGMN200	NLJ0516 L4.0
MFH216Q08-25-140	7.5	16	180	48	6	8	25	140		
MFH220R06-25-140	8	20	200	60	9	6	25	140		
MFH220R08-25-140	8	20	200	60	9	8	25	140		
MFH225S06-25-140	11.5	25	250	56	11.5	6	25	140	MGMN250	NLJ0520 L4.0
MFH225S06-25-140	11.5	25	250	56	11.5	8	25	140		
MFH2.516Q06-25-140	7.5	16	180	48	6	6	25	140		
MFH2.516Q08-25-140	7.5	16	180	48	6	8	25	140		
MFH2.520R06-25-140	8	20	200	60	9	6	25	140	MGMN300	NLJ0520 L4.0
MFH2.520R08-25-140	8	20	200	60	9	8	25	140		
MFH2.525S06-25-140	11.5	25	250	56	11.5	6	25	140		
MFH2.525S08-25-140	11.5	25	250	56	11.5	8	25	140		
MFH316Q06-25-140	7.5	16	180	48	6	6	25	140	MGMN300	NLJ0516 L4.0
MFH316Q08-25-140	7.5	16	180	48	6	8	25	140		
MFH320R08-25-140	8	20	200	60	9	6	25	140		
MFH320R10-25-140	8	20	200	60	9	10	25	140		
MFH325S08-25-140	11.5	25	250	56	11.5	8	25	140	MGMN300	NLJ0520 L4.0
MFH325S10-25-140	11.5	25	250	56	11.5	10	25	140		
MFH332S10-32-140	15	32	250	56	16	10	32	200		
MFH332S12-32-200	15	32	250	56	16	12	32	200		
MFH340T12-40-500	18	40	300	56	20	12	40	500	MGMN400	NLJ0625 L5.0
MFH420R08-25-140	8	20	200	60	9	8	25	140		
MFH420R12-25-140	8	20	200	60	9	8	25	140		
MFH425S06-25-140	11.5	25	250	56	11.5	8	25	140		
MFH425S10-25-140	11.5	25	250	56	11.5	10	25	140	MGMN400	NLJ0520 L4.0
MFH425S12-25-140	11.5	25	250	56	11.5	12	25	140		
MFH432S12-32-200	15	32	250	56	16	12	32	200		
MFH440T15-40-500	18	40	300	56	20	15	40	500		
MFH525S06-25-140	11.5	25	250	56	11.5	8	25	140	MGMN500	NLJ0625 L5.0
MFH525S12-25-140	11.5	25	250	56	11.5	12	25	140		
MFH540T15-40-500	18	40	300	56	20	15	40	500		

NDMR/L-T

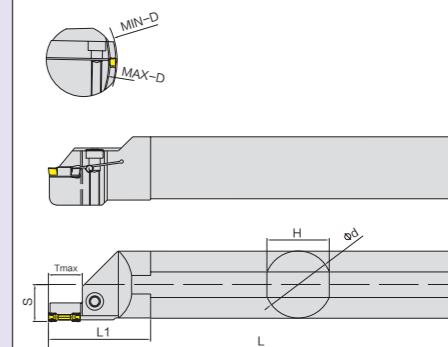
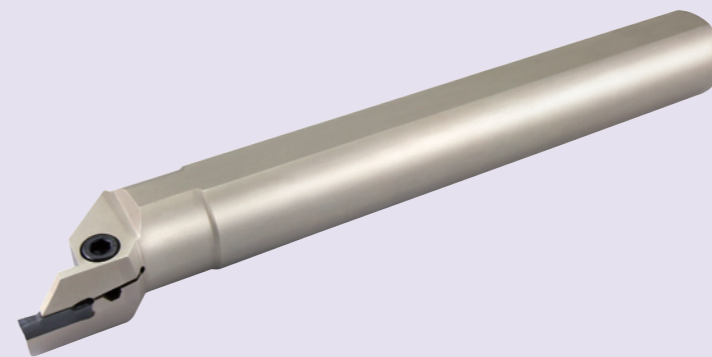

型号 Model	螺母NLJ Screw NLJ	扳手 Wrench	D _{最小加工}	d	L	L1	H	S	最小	最大	T _{max}		
												NDMR 320R25/60T5	HFPR3003 GRIP3003
NDMR 320R25/60T8	25	20	200	56	18	11	25	60	8				
NDMR 320R50/80T15	50	20	200	56	18	12	50	80	15				
NDMR 320R80/120T15	80	20	200	56	18	12	80	120	15				
NDMR 325R25/60T5	25	25	200	56	23	13.5	25	60	5				
NDMR 325R25/60T8	25	25	200	56	23	13.5	25	60	8				
NDMR 325S50/80T15	50	25	250	56	23	14.5	50	80	15				
NDMR 325S80/120T15	80	25	250	56	23	14.5	80	120	15				
NDMR 332R35/60T5	35	32	200	56	29	14.5	35	60	5				
NDMR 332R35/60T8	35	32	200	56	29	14.5	35	60	8				
NDMR 425S50/80T18	HFPR4004 GRIP4004	NLJ0620 L5.0	50	25	250	56	23	17	50	80	18		
NDMR 425S80/120T18			80	25	250	56	23	17	80	120	18		
NDMR 432S50/80T18			50	32	250	56	29	18	50	80	18		
NDMR 432S80/120T18			80	32	250	56	29	18	80	120	18		
NDMR 432R35/90T5			35	32	200	56	29	17.15	35	90	5		
NDMR 432R35/90T8			35	32	200	56	29	17.15	35	90	8		
NDMR 440R45/90T5			45	40	200	56	37	21.15	45	90	5		
NDMR 440R45/90T8			45	40	200	56	37	21.15	45	90	8		
NDMR 540S50/80T20	HFPR5008 GRIP5008	NLJ0625 L5.0	50	40	250	56	37	22	50	80	20		
NDMR 540S80/120T20			80	40	250	56	37	22	80	120	20		
NDMR 540S45/300T5			45	40	250	61	37	21	45	300	5		
NDMR 540S45/300T8			45	40	250	61	37	21	45	300	8		

内孔端面扣槽刀 Inner hole end buckle groove knife

小内径割刀 Small diameter cutting knife

MGHH **新品**

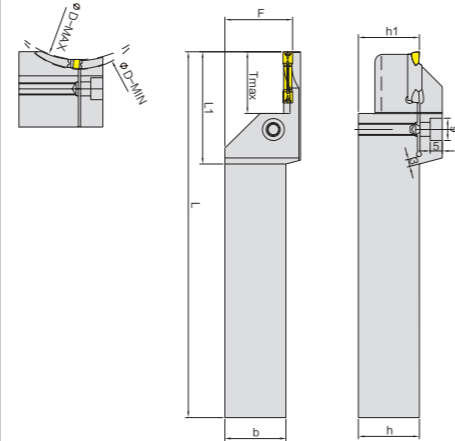

型号 Model		h	b	L	L1	F	Tmax	最小	最大	螺丝 Screw	扳手 Wrench	
MGHH320R18-25-50	MGMN300	20	20	125	40	21.8	18	25	50	NLJ0520	L4.0	
MGHH320R20-50-80		20	20	125	40	21.8	20	50	80			
MGHH320R25-80-160		20	20	125	45	21.8	25	80	160			
MGHH320R25-160-400		20	20	125	45	21.8	25	160	400			
MGHH325R18-25-50		MGMN400	25	25	150	40	27.8	18	25	52	NLJ0625	L5.0
MGHH325R20-50-80			25	25	150	40	27.8	20	50	80		
MGHH325R25-80-160			25	25	150	45	27.8	25	80	160		
MGHH325R25-160-400			25	25	150	45	27.8	25	160	400		
MGHH420R20-25-50	MGMN500		20	20	125	40	21.8	20	25	50	NLJ0520	L4.0
MGHH420R20-50-80			20	20	125	40	21.8	20	50	80		
MGHH420R25-80-160			20	20	125	45	21.8	25	80	160		
MGHH420R25-160-400			20	20	125	45	21.8	25	160	400		
MGHH425R20-25-50		25	25	150	40	27.8	20	25	50			
MGHH425R25-50-80		25	25	150	45	27.8	25	50	80			
MGHH425R25-80-160		25	25	150	45	27.8	25	80	160			
MGHH425R25-160-400		25	25	150	45	27.8	25	160	400			
MGHH425R30-80-160		25	25	150	50	27.8	30	80	160			
MGHH425R30-160-400		25	25	150	50	27.8	30	160	400			
MGHH425R40-80-160		25	25	150	60	27.8	40	80	160			
MGHH425R40-160-400		25	25	150	60	27.8	40	160	400			
MGHH432R25-50-100		32	32	170	46	34.8	25	50	100			
MGHH432R25-80-200		32	32	170	46	34.8	25	80	200			
MGHH432R25-200-600		32	32	170	46	34.8	25	200	600			
MGHH432R30-80-200		32	32	170	51	34.8	30	80	200			
MGHH432R30-200-600	32	32	170	51	34.8	30	200	600				
MGHH432R40-80-200	32	32	170	61	34.8	40	80	200				
MGHH432R40-200-600	32	32	170	61	34.8	40	200	600				
MGHH520R20-25-50	MGMN500	20	20	125	40	21.8	20	25	50	NLJ0520	L4.0	
MGHH520R25-50-80		20	20	125	40	21.8	25	50	80			
MGHH520R25-80-160		20	20	125	40	21.8	25	80	160			
MGHH520R25-160-400		20	20	125	45	21.8	25	160	400			
MGHH525R20-25-50		MGMN500	25	25	150	40	27.8	20	25	50	NLJ0625	L5.0
MGHH525R25-50-80			25	25	150	45	27.8	25	50	80		
MGHH525R25-80-160			25	25	150	45	27.8	25	80	160		
MGHH525R25-160-400			25	25	150	45	27.8	25	160	400		
MGHH525R30-80-160	25		25	150	50	27.8	30	80	160			
MGHH525R30-160-400	25		25	150	50	27.8	30	160	400			
MGHH532R25-50-100	32		32	170	46	34.8	25	50	100			

型号 Model		h	b	L	L1	F	Tmax	最小	最大	螺丝 Screw	扳手 Wrench
MGHH532R25-80-200	MGMN500	32	32	170	46	34.8	25	80	200	NLJ0625	L5.0
MGHH532R25-200-600		32	32	170	46	34.8	25	200	600		
MGHH532R30-80-200		32	32	170	51	34.8	30	80	200		
MGHH532R30-200-600		32	32	170	51	34.8	30	200	600		
MGHH532R40-80-200		32	32	170	61	34.8	40	80	200		
MGHH532R40-200-600		32	32	170	61	34.8	40	200	600		
MGHH532R50-80-200		32	32	170	71	34.8	50	80	200		
MGHH532R50-200-600		32	32	170	71	34.8	50	200	600		

45°外扣
内扣槽刀
45° Buckle buckle groove knife

45°外扣
内扣槽刀
45° Buckle buckle groove knife

FGDHX...

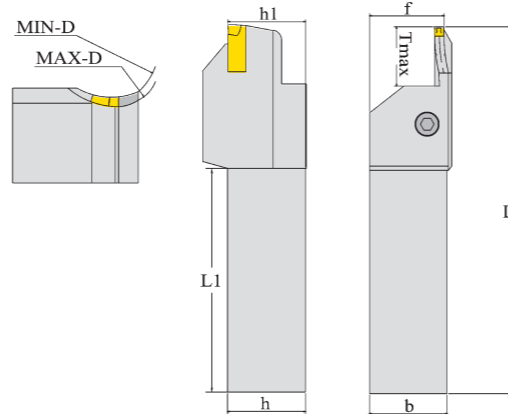

型号 Model	外槽加工, 车削加工 External groove machining, Lathe machining								螺丝NLJ Screw NLJ	扳手 Wrench				
	h	b	L	L1	f	T _{最大} Max	最小				最大			
1616 H-15/20-3	16	16	100	63	17.8	8	15	20	FMM300R	NLJ0520	L4.0			
1616 H-20/25-3	16	16	100	63			20	25						
1616 H-25/30-3	16	16	100	63		12	25	30						
1616 H-30/35-3	16	16	100	63			30	35						
1616 H-35/48-3	16	16	100	63			35	48						
2020 K-15/20-3	20	20	125	88	21.8	8	15	20				FGD300R FGM300R	NLJ0520	L4.0
2020 K-20/25-3	20	20	125	88			20	25						
2020 K-25/30-3	20	20	125	88		12	25	30						
2020 K-30/35-3	20	20	125	88			30	35						
2020 K-35/48-3	20	20	125	88			35	48						
2020 K-48/60-3	20	20	125	81		22	48	60						
2020 K-60/75-3	20	20	125	81			60	75						
2020 K-75/100-3	20	20	125	81		25	75	100						
2020 K-100/140-3	20	20	125	78			100	140						
2020 K-140/250-3	20	20	125	78			140	250						
2525 M-15/20-3	25	25	150	113	27.8		8	15	20	FMM300R	NLJ0520	L4.0		
2525 M-20/25-3	25	25	150	113		20		25						
2525 M-25/30-3	25	25	150	113		12	25	30						
2525 M-30/35-3	25	25	150	113			30	35						
2525 M-35/48-3	25	25	150	113			35	48						
2525 M-48/60-3	25	25	150	105		22	48	60						
2525 M-60/75-3	25	25	150	105			60	75						
2525 M-75/100-3	25	25	150	105		25	75	100						
2525 M-100/140-3	25	25	150	103			100	140						
2525 M-140/250-3	25	25	150	103			140	250						
1616 H-15/20-4	16	16	100	63	17.8		8	15	20	FMM400R	NLJ0520	L4.0		
1616 H-20/25-4	16	16	100	63		20		25						
1616 H-25/30-4	16	16	100	63		12	25	30						
1616 H-30/35-4	16	16	100	63			30	35						
1616 H-35/48-4	16	16	100	63			35	48						
2020 K-15/20-4	20	20	125	88	21.8	8	15	20	FGD400R FGM400R				NLJ0520	L4.0
2020 K-20/25-4	20	20	125	88			20	25						
2020 K-25/30-4	20	20	125	88		12	25	30						
2020 K-30/35-4	20	20	125	88			30	35						
2020 K-35/48-4	20	20	125	88			35	48						
2020 K-48/60-4	20	20	125	78		25	48	60						
2020 K-60/75-4	20	20	125	78			60	75						
2020 K-75/100-4	20	20	125	78		25	75	100						
2020 K-100/140-4	20	20	125	78			100	140						
2020 K-140/250-4	20	20	125	78			140	250						
2525 M-15/20-4	25	25	150	113	27.8		8	15	20	FMM400R	NLJ0520	L4.0		
2525 M-20/25-4	25	25	150	113		20		25						
2525 M-25/30-4	25	25	150	113		12	25	30						
2525 M-30/35-4	25	25	150	113			30	35						
2525 M-35/48-4	25	25	150	113			35	48						

型号 Model	外槽加工, 车削加工 External groove machining, Lathe machining								螺丝NLJ Screw NLJ	扳手 Wrench				
	h	b	L	L1	f	T _{最大} Max	最小				最大			
2525 M-48/60-4	25	25	150	103	27.8	25	48	60	FGD500R FGM500R	NLJ0520	L4.0			
2525 M-60/75-4	25	25	150	103			60	75						
2525 M-75/100-4	25	25	150	103			75	100						
2525 M-100/140-4	25	25	150	103			100	140						
2525 M-140/250-4	25	25	150	103			140	250						
1616 H-15/20-5	16	16	100	63	17.8	8	15	20	FMM500R	NLJ0520	L4.0			
1616 H-20/25-5	16	16	100	63			20	25						
1616 H-25/30-5	16	16	100	63		12	25	30						
1616 H-30/35-5	16	16	100	63			30	35						
1616 H-35/48-5	16	16	100	63			35	48						
2020 K-15/20-5	20	20	125	88	21.8	8	15	20				FGD500R FGM500R	NLJ0520	L4.0
2020 K-20/25-5	20	20	125	88			20	25						
2020 K-25/30-5	20	20	125	88		12	25	30						
2020 K-30/35-5	20	20	125	88			30	35						
2020 K-35/48-5	20	20	125	88			35	48						
2020 K-48/60-5	20	20	125	78		25	48	60						
2020 K-60/75-5	20	20	125	78			60	75						
2020 K-75/100-5	20	20	125	78		25	75	100						
2020 K-100/140-5	20	20	125	78			100	140						
2020 K-140/250-5	20	20	125	78			140	250						
2525 M-15/20-5	25	25	150	113	27.8		8	15	20	FMM500R	NLJ0520	L4.0		
2525 M-20/25-5	25	25	150	113		20		25						
2525 M-25/30-5	25	25	150	113		12	25	30						
2525 M-30/35-5	25	25	150	113			30	35						
2525 M-35/48-5	25	25	150	113			35	48						
2525 M-48/60-5	25	25	150	103		25	48	60						
2525 M-60/75-5	25	25	150	103			60	75						
2525 M-75/100-5	25	25	150	103		25	75	100						
2525 M-100/140-5	25	25	150	103			100	140						
2525 M-140/250-5	25	25	150	103			140	250						

此款割刀匹配的是克洛依的刀片槽

FGEHX...

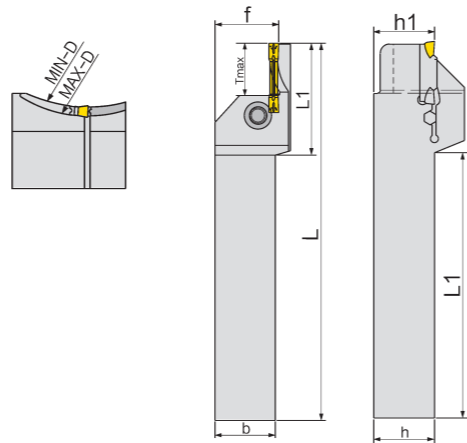
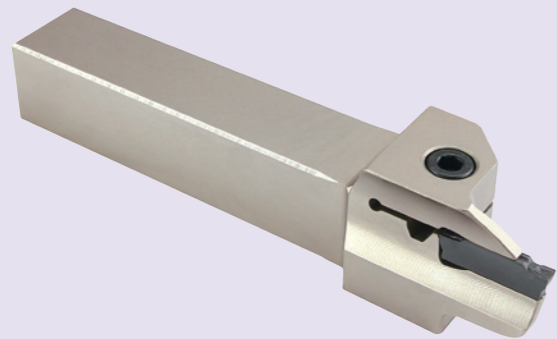

型号 Model	外槽加工, 车削加工 External groove machining, Lathe machining										螺丝NLJ Screw NLJ	扳手 Wrench	
	h	b	L	L1	I1	f	h1	T _{最大} Max	最小	最大			
1616 H20/25-2T5	16	16	100	65	35			5	20	25	MGMN200		
1616 H20/25-2T10	16	16	100	65	35			10	20	25			
1616 H25/30-2T5	16	16	100	65	35			5	25	30			
1616 H25/30-2T10	16	16	100	65	35			10	25	30			
1616 H30/40-2T5	16	16	100	65	35			5	30	40			
1616 H30/40-2T10	16	16	100	65	35			10	30	40			
1616 H40/60-2T5	16	16	100	65	35			5	40	60			
1616 H40/60-2T10	16	16	100	65	35			10	40	60			
2020 K20/25-2T5	20	20	125	90	35			5	20	25			
2020 K20/25-2T10	20	20	125	90	35			10	20	25			
2020 K25/30-2T5	20	20	125	90	35			5	25	30			
2020 K25/30-2T10	20	20	125	90	35			10	25	30			
2020 K30/40-2T5	20	20	125	90	35			5	30	40			
2020 K30/40-2T10	20	20	125	90	35			10	30	40			
2020 K40/60-2T5	20	20	125	90	35			5	40	60			
2020 K40/60-2T10	20	20	125	90	35			10	40	60			
2020 K60/90-2T5	20	20	125	90	35			5	60	90			
2020 K60/90-2T10	20	20	125	90	35			10	60	90			
2020 K90/120-2T5	20	20	125	90	35			5	90	120			
2020 K90/120-2T10	20	20	125	90	35			10	90	120			
2020 K25/40-3T8	20	20	125	88	37			8	25	40			
2020 K25/40-3T12	20	20	125	88	37			12	25	40			
2020 K40/60-3T12	20	20	125	88	37			12	40	60			
2020 K40/60-3T18	20	20	125	88	37			18	40	60			
2020 K60/90-3T8	20	20	125	88	37			8	60	90			
2020 K60/90-3T12	20	20	125	88	37			12	60	90			
2020 K60/90-3T18	20	20	125	88	37			18	60	90			
2020 K90/120-3T8	20	20	125	88	37			8	90	120			
2020 K90/120-3T12	20	20	125	88	37			12	90	120			
2020 K90/120-3T18	20	20	125	88	37			18	90	120			
2020 K120/250-3T8	20	20	125	88	37			8	120	250			
2020 K120/250-3T12	20	20	125	88	37			12	120	250			
2020 K120/250-3T18	20	20	125	88	37			18	120	250			
2020 K25/40-4T9	20	20	125	88	37			9	25	40			
2020 K25/40-4T14	20	20	125	88	37			14	25	40			
2020 K25/40-4T20	20	20	125	85	40			20	25	40			
2020 K40/60-4T9	20	20	125	88	37			9	40	60			
2020 K40/60-4T14	20	20	125	88	37			14	40	60			
2020 K40/60-4T20	20	20	125	85	40			20	40	60			
2020 K60/90-4T9	20	20	125	88	37			9	60	90			
2020 K60/90-4T14	20	20	125	88	37			14	60	90			
2020 K60/90-4T20	20	20	125	85	40			20	60	90			
2020 K90/120-4T9	20	20	125	88	37			9	90	120			
2020 K90/120-4T14	20	20	125	88	37			14	90	120			
2020 K90/120-4T20	20	20	125	85	40			20	90	120			
2020 K120/250-4T9	20	20	125	88	37			9	120	250			
2020 K120/250-4T14	20	20	125	88	37			14	120	250			
2020 K120/250-4T20	20	20	125	85	40			20	120	250			
2020 K250/500-4T20	20	20	125	85	40			20	250	500			
2020 K25/40-5T12	20	20	125	88	37			12	25	40			
2020 K25/40-5T18	20	20	125	88	37			18	25	40			

型号 Model	外槽加工, 车削加工 External groove machining, Lathe machining										螺丝NLJ Screw NLJ	扳手 Wrench				
	h	b	L	L1	I1	f	h1	T _{最大} Max	最小	最大						
2020 K25/40-5T25	20	20	125	80	45			25	25	40	MGMN500					
2020 K40/60-5T12	20	20	125	88	37			12	40	60						
2020 K40/60-5T18	20	20	125	88	37			18	40	60						
2020 K40/60-5T25	20	20	125	80	45			25	40	60						
2020 K60/90-5T12	20	20	125	88	37			12	60	90						
2020 K60/90-5T18	20	20	125	88	37			18	60	90						
2020 K60/90-5T25	20	20	125	80	45			25	60	90						
2020 K90/120-5T12	20	20	125	88	37			12	90	120						
2020 K90/120-5T18	20	20	125	88	37			18	90	120						
2020 K90/120-5T25	20	20	125	80	45			25	90	120						
2020 K120/250-5T12	20	20	125	88	37			12	120	250						
2020 K120/250-5T18	20	20	125	88	37			18	120	250						
2020 K120/250-5T25	20	20	125	80	45			25	120	250						
2020 K250/500-5T12	20	20	125	88	37			12	250	500						
2020 K250/500-5T18	20	20	125	88	37			18	250	500						
2020 K250/500-5T25	20	20	125	80	45			25	250	500						
2525 M20/25-2T5	25	25	150	115	35			5	20	25				MGMN200		
2525 M20/25-2T10	25	25	150	115	35			10	20	25						
2525 M25/30-2T5	25	25	150	115	35			5	25	30						
2525 M25/30-2T10	25	25	150	115	35			10	25	30						
2525 M30/40-2T5	25	25	150	115	35			5	30	40						
2525 M30/40-2T10	25	25	150	115	35			10	30	40						
2525 M40/60-2T5	25	25	150	115	35			5	40	60						
2525 M40/60-2T10	25	25	150	115	35			10	40	60						
2525 M60/90-2T5	25	25	150	115	35			5	60	90						
2525 M60/90-2T10	25	25	150	115	35			10	60	90						
2525 M90/120-2T5	25	25	150	115	35			5	90	120						
2525 M90/120-2T10	25	25	150	115	35			10	90	120						
2525 M25/40-3T8	25	25	150	113	37			8	25	40						
2525 M25/40-3T12	25	25	150	113	37			12	25	40						
2525 M40/60-3T12	25	25	150	113	37			12	40	60						
2525 M40/60-3T18	25	25	150	113	37			18	40	60						
2525 M60/90-3T8	25	25	150	113	37			8	60	90						
2525 M60/90-3T12	25	25	150	113	37			12	60	90						
2525 M60/90-3T18	25	25	150	113	37			18	60	90						
2525 M90/120-3T8	25	25	150	113	37			8	90	120						
2525 M90/120-3T12	25	25	150	113	37			12	90	120						
2525 M90/120-3T18	25	25	150	113	37			18	90	120						
2525 M120/250-3T8	25	25	150	113	37			8	120	250						
2525 M120/250-3T12	25	25	150	113	37			12	120	250						
2525 M120/250-3T18	25	25	150	113	37			18	120	250						
2525 M25/40-4T9	25	25	150	113	37			9	25	40						
2525 M25/40-4T14	25	25	150	113	37			14	25	40						
2525 M25/40-4T20	25	25	150	110	40			20	25	40						
2525 M40/60-4T9	25	25	150	113	37			9	40	60						
2525 M40/60-4T14	25	25	150	113	37			14	40	60						
2525 M40/60-4T20	25	25	150	110	40			20	40	60						
2525 M60/90-4T9	25	25	150	113	37			9	60	90						
2525 M60/90-4T14	25	25	150	113	37			14	60	90						
2525 M60/90-4T20	25	25	150	110	40			20	60	90						
2525 M90/120-4T9	25	25	150	113	37			9	90	120						
2525 M90/120-4T14	25	25	150	113	37			14	90	120						
2525 M90/120-4T20	25	25	150	110	40			20	90	120						
2525 M120/250-4T9	25	25	150	113	37			9	120	250						
2525 M120/250-4T14	25	25	150	113	37			14	120	250						
2525 M120/250-4T20	25	25	150	110	40			20	120	250						
2525 M250/500-4T20	25	25	150	110	40			20	250	500						
2525 M25/40-5T12	25	25	150	113	37			12	25	40						
2525 M25/40-5T18	25	25	150	113	37			18	25	40						
2525 M25/40-5T25	25	25	150	105	45			25	25	40						
2525 M40/60-5T12	25	25	150	113	37			12	40	60						
2525 M40/60-5T18	25	25	150	113	37			18	40	60						
2525 M40/60-5T25	25	25	150	105	45			25	40	60						
2525 M60/90-5T12	25	25	150	113	37			12	60	90						
2525 M60/90-5T18	25	25	150	113	37			18	60	90						
2525 M60/90-5T25	25	25	150	105	45			25	60	90						
2525 M90/120-5T12	25	25	150	113	37			12	90	120						
2525 M90/120-5T18	25	25	150	113	37			18	90	120						
2525 M90/120-5T25	25	25	150	105	45			25	90	120						
2525 M120/250-5T12	25	25	150	113	37			12	120	250						
2525 M120/250-5T18	25	25	150	113	37			18	120	250						
2525 M120/250-5T25	25	25	150	105	45			25	120	250						
2525 M250/500-5T12	25	25	150	113	37			12	250	500						
2525 M250/500-5T18	25	25	150	113	37			18	250	500						
2525 M250/500-5T25	25	25	150	105	45			25	250	500						

WDMR...

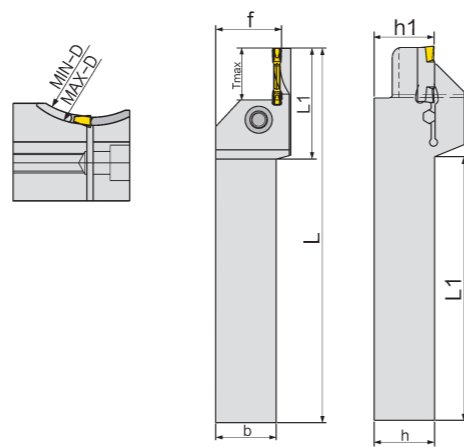

型号 Model	外槽加工, 车削加工 External groove machining, Lathe machining										 螺丝NLJ Screw NLJ	 扳手 Wrench	
	h	b	L	L1	l1	f	h1	T _{最大} Max	最小	最大			
2020 K20/30-3T12	20	20	125	88	37			12	20	30	HFPR3003 GRIP3003	NLJ0520	L4.0
2020 K20/38-3T8	20	20	125	88	37			8	20	38			
2020 K20/38-3T12	20	20	125	88	37			12	20	38			
2020 K25/30-3T8	20	20	125	88	37			8	25	30			
2020 K25/30-3T12	20	20	125	88	37			12	25	30			
2020 K30/38-3T8	20	20	125	88	37			8	30	38			
2020 K30/38-3T12	20	20	125	88	37			12	30	38			
2020 K38/48-3T8	20	20	125	88	37			8	38	48			
2020 K38/48-3T12	20	20	125	88	37			12	38	48			
2020 K38/48-3T17	20	20	125	88	37			17	38	48			
2020 K48/60-3T12	20	20	125	88	37			12	48	60			
2020 K48/60-3T17	20	20	125	88	37			17	48	60			
2020 K48/60-3T22	20	20	125	85	40			22	48	60			
2020 K60/75-3T12	20	20	125	88	37			12	60	75			
2020 K60/75-3T17	20	20	125	88	37			17	60	75			
2020 K60/75-3T22	20	20	125	85	40			22	60	75			
2020 K60/75-3T27	20	20	125	80	45			27	60	75			
2020 K75/100-3T12	20	20	125	88	37			12	75	100			
2020 K75/100-3T17	20	20	125	88	37			17	75	100			
2020 K75/100-3T22	20	20	125	85	40			22	75	100			
2020 K75/100-3T27	20	20	125	80	45			27	75	100			
2020 K100/140-3T12	20	20	125	88	37	21.8	20	12	100	140			
2020 K100/140-3T17	20	20	125	88	37			17	100	140			
2020 K100/140-3T22	20	20	125	85	40			22	100	140			
2020 K100/140-3T27	20	20	125	80	45			27	100	140			
2020 K140/240-3T12	20	20	125	88	37			12	140	240			
2020 K140/240-3T17	20	20	125	88	37			17	140	240			
2020 K140/240-3T22	20	20	125	85	40			22	140	240			
2020 K140/240-3T27	20	20	125	80	45			27	140	240			
2020 K200/800-3T12	20	20	125	88	37			12	200	800			
2020 K200/800-3T17	20	20	125	88	37			17	200	800			
2020 K200/800-3T22	20	20	125	85	40			22	200	800			
2020 K200/800-3T27	20	20	125	80	45			27	200	800			
2020 K25/30-4T8	20	20	125	88	37			8	25	30			
2020 K25/30-4T12	20	20	125	88	37			12	25	30			
2020 K30/38-4T8	20	20	125	88	37			8	30	38			
2020 K30/38-4T12	20	20	125	88	37			12	30	38			
2020 K38/48-4T8	20	20	125	88	37			8	38	48			
2020 K38/48-4T12	20	20	125	88	37			12	38	48			
2020 K38/48-4T17	20	20	125	88	37			17	38	48			
2020 K48/60-4T12	20	20	125	88	37			12	48	60			
2020 K48/60-4T17	20	20	125	88	37			17	48	60			
2020 K48/60-4T22	20	20	125	85	40			22	48	60			
2020 K60/75-4T12	20	20	125	88	37			12	60	75			
2020 K60/75-4T17	20	20	125	88	37			17	60	75			

型号 Model	外槽加工, 车削加工 External groove machining, Lathe machining										 螺丝NLJ Screw NLJ	 扳手 Wrench	
	h	b	L	L1	l1	f	h1	T _{最大} Max	最小	最大			
2020 K60/75-4T22	20	20	125	85	40			22	60	75	HFPR4004 GRIP4004		
2020 K60/75-4T27	20	20	125	80	45			27	60	75			
2020 K75/100-4T12	20	20	125	88	37			12	75	100			
2020 K75/100-4T17	20	20	125	88	37			17	75	100			
2020 K75/100-4T22	20	20	125	85	40			22	75	100			
2020 K75/100-4T27	20	20	125	80	45			27	75	100			
2020 K100/140-4T12	20	20	125	88	37			12	100	140			
2020 K100/140-4T17	20	20	125	88	37			17	100	140			
2020 K100/140-4T22	20	20	125	85	40			22	100	140			
2020 K100/140-4T27	20	20	125	80	45			27	100	140			
2020 K140/240-4T12	20	20	125	88	37			12	140	240			
2020 K140/240-4T17	20	20	125	88	37			17	140	240			
2020 K140/240-4T22	20	20	125	85	40			22	140	240			
2020 K140/240-4T27	20	20	125	80	45			27	140	240			
2020 K200/800-4T12	20	20	125	88	37			12	200	800			
2020 K200/800-4T17	20	20	125	88	37			17	200	800			
2020 K200/800-4T22	20	20	125	85	40			22	200	800			
2020 K200/800-4T27	20	20	125	80	45			27	200	800			
2020 K25/30-5T10	20	20	125	88	37			10	25	30			
2020 K25/30-5T14	20	20	125	88	37			14	25	30			
2020 K30/38-5T10	20	20	125	88	37			10	30	38			
2020 K30/38-5T14	20	20	125	88	37			14	30	38			
2020 K30/38-5T18	20	20	125	88	37			18	30	38			
2020 K38/48-5T10	20	20	125	88	37	21.8	20	10	38	48			
2020 K38/48-5T14	20	20	125	88	37			14	38	48			
2020 K38/48-5T18	20	20	125	88	37			18	38	48			
2020 K48/60-5T12	20	20	125	88	37			12	48	60			
2020 K48/60-5T17	20	20	125	88	37			17	48	60			
2020 K48/60-5T22	20	20	125	85	40			22	48	60			
2020 K60/75-5T12	20	20	125	88	37			12	60	75			
2020 K60/75-5T17	20	20	125	88	37			17	60	75			
2020 K60/75-5T22	20	20	125	85	40			22	60	75			
2020 K60/75-5T27	20	20	125	80	45			27	60	75			
2020 K75/100-5T12	20	20	125	88	37			12	75	100			
2020 K75/100-5T17	20	20	125	88	37			17	75	100			
2020 K75/100-5T22	20	20	125	85	40			22	75	100			
2020 K75/100-5T27	20	20	125	80	45			27	75	100			
2020 K100/140-5T12	20	20	125	88	37			12	100	140			
2020 K100/140-5T17	20	20	125	88	37			17	100	140			
2020 K100/140-5T22	20	20	125	85	40			22	100	140			
2020 K100/140-5T27	20	20	125	80	45			27	100	140			
2020 K140/250-5T12	20	20	125	88	37			12	140	250			
2020 K140/250-5T17	20	20	125	88	37			17	140	250			
2020 K140/250-5T22	20	20	125	85	40			22	140	250			
2020 K140/250-5T27	20	20	125	80	45			27	140	250			
2020 K200/800-5T12	20	20	125	88	37			12	200	800			
2020 K200/800-5T17	20	20	125	88	37			17	200	800			
2020 K200/800-5T22	20	20	125	85	40			22	200	800			
2020 K200/800-5T27	20	20	125	80	45			27	200	800			
2525 M25/30-3T8	25	25	150	113	37			8	25	30			
2525 M25/30-3T12	25	25	150	113	37			12	25	30			
2525 M30/38-3T8	25	25	150	113	37			8	30	38			
2525 M30/38-3T12	25	25	150	113	37			12	30	38			
2525 M38/48-3T8	25	25	150	113	37			8	38	48			
2525 M38/48-3T12	25	25	150	113	37			12	38	48			
2525 M38/48-3T17	25	25	150	113	37			17	38	48			
2525 M48/60-3T12	25	25	150	113	37	27.8	25	12	48	60			
2525 M48/60-3T17	25	25	150	113	37			17	48	60			
2525 M48/60-3T22	25	25	150	110	40			22	48	60			
2525 M60/75-3T12	25	25	150	113	37			12	60	75			
2525 M60/75-3T17	25	25	150	113	37			17	60	75			
2525 M60/75-3T22	25	25	150	110	40			22	60	75			
2525 M60/75-3T27	25	25	150	105	45			27	60	75			

端面扣槽刀 End groove cutter

端面扣槽刀 End groove cutter

型号 Model	外槽加工, 车削加工 External groove machining, Lathe machining											螺丝NLJ Screw NLJ	扳手 Wrench			
	h	b	L	L1	l1	f	h1	T _{最大} Max	最小	最大						
2525 M75/100-3T12	25	25	150	113	37			12	75	100	HFPR3003 GRIP3003					
2525 M75/100-3T17	25	25	150	113	37			17	75	100						
2525 M75/100-3T22	25	25	150	110	40			22	75	100						
2525 M75/100-3T27	25	25	150	105	45			27	75	100						
2525 M100/140-3T12	25	25	150	113	37			12	100	140						
2525 M100/140-3T17	25	25	150	113	37			17	100	140						
2525 M100/140-3T22	25	25	150	110	40			22	100	140						
2525 M100/140-3T27	25	25	150	105	45			27	100	140						
2525 M140/240-3T12	25	25	150	113	37			12	140	240						
2525 M140/240-3T17	25	25	150	113	37			17	140	240						
2525 M140/240-3T22	25	25	150	110	40			22	140	240						
2525 M140/240-3T27	25	25	150	105	45			27	140	240						
2525 M200/800-3T12	25	25	150	113	37			12	200	800						
2525 M200/800-3T17	25	25	150	113	37			17	200	800						
2525 M200/800-3T22	25	25	150	110	40			22	200	800						
2525 M200/800-3T27	25	25	150	105	45			27	200	800						
2525 M25/30-4T8	25	25	150	113	37			8	25	30				HFPR4004 GRIP4004	NLJ0520	L4.0
2525 M25/30-4T12	25	25	150	113	37			12	25	30						
2525 M30/38-4T8	25	25	150	113	37			8	30	38						
2525 M30/38-4T12	25	25	150	113	37			12	30	38						
2525 M38/48-4T8	25	25	150	113	37			8	38	48						
2525 M38/48-4T12	25	25	150	113	37			12	38	48						
2525 M38/48-4T17	25	25	150	113	37			17	38	48						
2525 M48/60-4T12	25	25	150	113	37			12	48	60						
2525 M48/60-4T17	25	25	150	113	37			17	48	60						
2525 M48/60-4T22	25	25	150	110	40			22	48	60						
2525 M60/75-4T12	25	25	150	113	37			12	60	75						
2525 M60/75-4T17	25	25	150	113	37	27.8	25	17	60	75						
2525 M60/75-4T22	25	25	150	110	40			22	60	75						
2525 M60/75-4T27	25	25	150	105	45			27	60	75						
2525 M75/100-4T12	25	25	150	113	37			12	75	100						
2525 M75/100-4T17	25	25	150	113	37			17	75	100						
2525 M75/100-4T22	25	25	150	110	40			22	75	100						
2525 M75/100-4T27	25	25	150	105	45			27	75	100						
2525 M100/140-4T12	25	25	150	113	37			12	100	140						
2525 M100/140-4T17	25	25	150	113	37			17	100	140						
2525 M100/140-4T22	25	25	150	110	40			22	100	140						
2525 M100/140-4T27	25	25	150	105	45			27	100	140						
2525 M140/240-4T12	25	25	150	113	37			12	140	240						
2525 M140/240-4T17	25	25	150	113	37			17	140	240						
2525 M140/240-4T22	25	25	150	110	40			22	140	240						
2525 M140/240-4T27	25	25	150	105	45			27	140	240						
2525 M200/800-4T12	25	25	150	113	37			12	200	800						
2525 M200/800-4T17	25	25	150	113	37			17	200	800						
2525 M200/800-4T22	25	25	150	110	40			22	200	800						
2525 M200/800-4T27	25	25	150	105	45			27	200	800						
2525 M25/30-5T8	25	25	150	113	37			8	25	30	HFPR5004 GRIP5004					
2525 M25/30-5T12	25	25	150	113	37			12	25	30						
2525 M30/38-5T8	25	25	150	113	37			8	30	38						
2525 M30/38-5T12	25	25	150	113	37			12	30	38						
2525 M30/38-5T17	25	25	150	113	37			17	30	38						
2525 M38/48-5T8	25	25	150	113	37			8	38	48						
2525 M38/48-5T12	25	25	150	113	37			12	38	48						
2525 M38/48-5T17	25	25	150	113	37			17	38	48						
2525 M48/60-5T12	25	25	150	113	37			12	48	60						
2525 M48/60-5T17	25	25	150	113	37			17	48	60						
2525 M48/60-5T22	25	25	150	110	40			22	48	60						
2525 M60/75-5T12	25	25	150	113	37			12	60	75						
2525 M60/75-5T17	25	25	150	113	37			17	60	75						
2525 M60/75-5T22	25	25	150	110	40			22	60	75						
2525 M60/75-5T27	25	25	150	105	45			27	60	75						
2525 M75/100-5T12	25	25	150	113	37			12	75	100						
2525 M75/100-5T17	25	25	150	113	37			17	75	100						

型号 Model	外槽加工, 车削加工 External groove machining, Lathe machining											螺丝NLJ Screw NLJ	扳手 Wrench
	h	b	L	L1	l1	f	h1	T _{最大} Max	最小	最大			
2525 M75/100-5T22	25	25	150	110	40			22	75	100	HFPR5004 GRIP5004	NLJ0520	L4.0
2525 M75/100-5T27	25	25	150	105	45			27	75	100			
2525 M100/140-5T12	25	25	150	113	37			12	100	140			
2525 M100/140-5T17	25	25	150	113	37			17	100	140			
2525 M100/140-5T22	25	25	150	110	40			22	100	140			
2525 M100/140-5T27	25	25	150	105	45			27	100	140			
2525 M140/250-5T12	25	25	150	113	37	27.8	25	12	140	250			
2525 M140/250-5T17	25	25	150	113	37			17	140	250			
2525 M140/250-5T22	25	25	150	110	40			22	140	250			
2525 M140/250-5T27	25	25	150	105	45			27	140	250			
2525 M200/800-5T12	25	25	150	113	37			12	200	800			
2525 M200/800-5T17	25	25	150	113	37			17	200	800			
2525 M200/800-5T22	25	25	150	110	40			22	200	800			
2525 M200/800-5T27	25	25	150	105	45			27	200	800			



此款割刀匹配的是悍狮霸的刀片槽

MGFHR/L

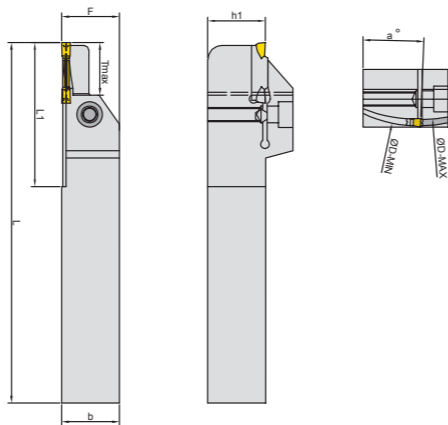

型号 Model	外槽加工, 车削加工 External groove machining, Lathe machining									螺丝NLJ Screw NLJ	扳手 Wrench	
	b	L	L1	F	h1	T _{最大}	最小	最大	a°			
2020 K-20/25-2T5	20	125	33			5	20	25	8°	MGMN200	NLJ0520	L4.0
2020 K-20/25-2T10	20	125	33			10	20	25	8°			
2020 K-25/30-2T5	20	125	33			5	25	30	6.45°			
2020 K-25/30-2T10	20	125	33			10	25	30	6.45°			
2020 K-30/40-2T5	20	125	33			5	30	40	5°			
2020 K-30/40-2T10	20	125	33			10	30	40	5°			
2020 K-40/60-2T5	20	125	30			5	40	60	4°			
2020 K-40/60-2T10	20	125	30			10	40	60	4°			
2020 K-60/90-2T5	20	125	50			5	60	90	2.5°			
2020 K-60/90-2T10	20	125	50			10	60	90	2.5°			
2020 K-90/120-2T5	20	125	50			5	90	120	2.5°			
2020 K-90/120-2T10	20	125	50			10	90	120	2.5°			
2020 K-25/40-3T8	20	125	38			8	25	40	8°			
2020 K-25/40-3T12	20	125	38			12	25	40	8°			
2020 K-40/60-3T12	20	125	50			12	40	60	5°			
2020 K-40/60-3T16	20	125	50			16	40	60	5°			
2020 K-60/90-3T15	20	125	50			15	60	90	2.5°			
2020 K-60/90-3T20	20	125	50			20	60	90	2.5°			
2020 K-90/120-3T12	20	125	50			12	90	120	2.5°			
2020 K-90/120-3T18	20	125	50			18	90	120	2.5°			
2020 K-120/250-3T20	20	125	50	20	20	20	120	250	2.5°			
2020 K-120/250-3T25	20	125	50			25	120	250	2.5°			
2020 K-25/40-4T8	20	125	38			12	25	40	8°			
2020 K-25/40-4T12	20	125	38			16	25	40	8°			
2020 K-40/60-4T12	20	125	50			15	40	60	5°			
2020 K-40/60-4T16	20	125	50			20	40	60	5°			
2020 K-60/90-4T15	20	125	50			12	60	90	4°			
2020 K-60/90-4T20	20	125	50			18	90	120	4°			
2020 K-90/120-4T18	20	125	50			20	90	120	2.5°			
2020 K-120/250-4T20	20	125	50			25	120	250	2.5°			
2020 K-120/250-4T25	20	125	50			25	120	250	2.5°			
2020 K-40/60-5T10	20	125	50			10	40	60	6.45°			
2020 K-40/60-5T15	20	125	50			15	40	60	6.45°			
2020 K-40/60-5T20	20	125	50			20	40	60	6.45°			
2020 K-60/90-5T10	20	125	50			10	60	90	5°			
2020 K-60/90-5T15	20	125	50			15	60	90	5°			
2020 K-60/90-5T20	20	125	50			20	60	90	5°			
2020 K-90/120-5T10	20	125	50			10	90	120	2.5°			
2020 K-90/120-5T15	20	125	50			15	90	120	2.5°			
2020 K-90/120-5T20	20	125	50			20	90	120	2.5°			
2020 K-120/250-5T20	20	125	50			20	120	250	2.5°			
2020 K-120/250-5T25	20	150	50			25	120	250	2.5°			
2525 M20/25-2T5	25	150	38			5	20	25	8°			
2525 M20/25-2T10	25	150	38			10	20	25	8°			
2525 M25/30-2T5	25	150	38	25	25	5	25	30	8°			
2525 M25/30-2T10	25	150	38			10	25	30	8°			
2525 M30/40-2T5	25	150	38			5	30	40	5°			
2525 M30/40-2T10	25	150	38			10	30	40	5°			

型号 Model	外槽加工, 车削加工 External groove machining, Lathe machining									螺丝NLJ Screw NLJ	扳手 Wrench	
	b	L	L1	F	h1	T _{最大}	最小	最大	a°			
2525 M40/60-2T5	25	150	38			5	40	60	4°	MGMN200		
2525 M40/60-2T10	25	150	38			10	40	60	4°			
2525 M60/90-2T5	25	150	38			5	60	90	2.5°			
2525 M60/90-2T10	25	150	38			10	60	90	2.5°			
2525 M90/120-2T5	25	150	38			5	90	120	2.5°			
2525 M90/120-2T10	25	150	38			10	90	120	2.5°			
2525 M25/40-3T8	25	150	38			8	25	40	8°			
2525 M25/40-3T12	25	150	38			12	25	40	8°			
2525 M40/60-3T12	25	150	38			12	40	60	5°			
2525 M40/60-3T16	25	150	38			16	40	60	5°			
2525 M60/90-3T15	25	150	42			15	60	90	4°			
2525 M60/90-3T20	25	150	42			20	60	90	4°			
2525 M90/120-3T18	25	150	50			18	90	120	4°			
2525 M120/250-3T20	25	150	50			20	120	250	2.5°			
2525 M120/250-3T25	25	150	50			25	120	250	2.5°			
2525 M25/40-4T8	25	150	38	25	25	8	25	40	8°			
2525 M25/40-4T12	25	150	38			12	25	40	8°			
2525 M40/60-4T12	25	150	38			12	40	60	5°			
2525 M40/60-4T16	25	150	38			16	40	60	5°			
2525 M60/90-4T15	25	150	50			15	60	90	4°			
2525 M60/90-4T20	25	150	50			20	60	90	4°			
2525 M90/120-4T18	25	150	50			18	90	120	4°			
2525 M120/250-4T20	25	150	48			20	120	250	2.5°			
2525 M120/250-4T25	25	150	48			25	120	250	2.5°			
2525 M50/80-4T25	25	150	47			25	50	80	5°			
2525 M50/80-4T30	25	150	47			30	50	80	5°			
2525 M80/160-4T25	25	150	52			25	80	160	2.5°			
2525 M80/160-4T30	25	150	52			30	80	160	2.5°			
2525 M100/200-4T30	25	150	55			30	100	200	2.5°			
2525 M140/400-4T30	25	150	55			30	140	400	2.5°			
2525 M200/800-4T30	25	150	55			30	200	800	0°			
2525 M200/800-4T22	25	150	55			22	200	800	0°			
2525 M40/60-5T10	25	150	42			10	40	60	5°			
2525 M40/60-5T15	25	150	42			15	40	60	5°			
2525 M40/60-5T20	25	150	42			20	40	60	5°			
2525 M60/90-5T10	25	150	50			10	60	90	2.5°			
2525 M60/90-5T15	25	150	50			15	60	90	2.5°			
2525 M60/90-5T20	25	150	50			20	60	90	2.5°			
2525 M90/120-5T10	25	150	50			10	90	120	2.5°			
2525 M90/120-5T15	25	150	50			15	90	120	2.5°			
2525 M90/120-5T20	25	150	50			20	90	120	2.5°			
2525 M120/250-5T20	25	150	50			20	120	250	0°			
2525 M120/250-5T25	25	150	50			25	120	250	0°			
2525 M80/160-5T30	25	150	55			30	80	160	2.5°			
2525 M80/160-5T40	25	150	65			40	80	160	2.5°			
2525 M100/300-5T30	25	150	55			30	100	300	2.5°			
2525 M140/400-5T35	25	150	60			35	140	400	2.5°			
2525 M200/800-5T40	25	150	65			40	200	800	0°			



此款割刀匹配的是悍狮霸、克洛依的刀片槽

STEHR/L

新品

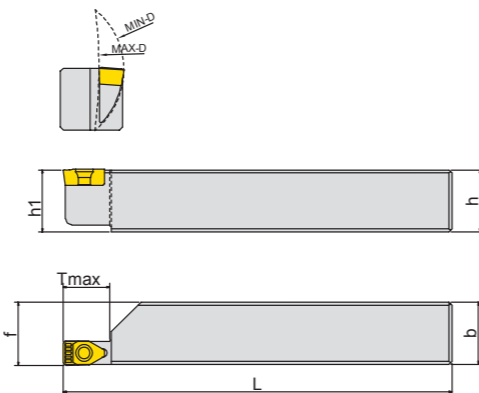
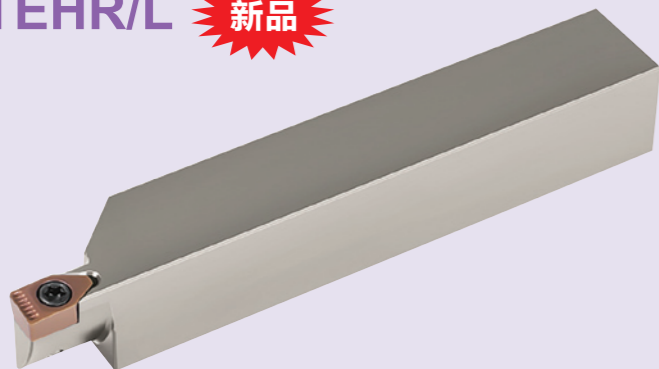

型号 Model	外槽加工, 车削加工 External groove machining, Lathe machining									TIGER Screw NLJ	扳手 Wrench
	h	b	L	F	h1	T _{最大}	最小	最大			
2020K08-50-300-T15	20	20	125	20.4	20	15	50	∞	TIGER 080508	M3.5	T-15
2020K08-50-300-T30	20	20	125	20.4	20	30	50	∞	TIGER 100508	M4.0	T-15
2020K10-50-300-T15	20	20	125	20.4	20	15	50	∞	TIGER 120508	M5.0	T-20
2020K10-50-300-T30	20	20	125	20.4	20	30	50	∞			
2020K12-50-300-T15	20	20	125	20.4	20	15	50	∞			
2020K12-50-300-T30	20	20	125	20.4	20	30	50	∞			
2525M08-50-80-T15	25	25	150	25.4	25	15	50	∞	TIGER 080508	M3.5	T-15
2525M08-50-80-T30	25	25	150	25.4	25	30	50	∞			
2525M08-50-80-T45	25	25	150	25.4	25	45	50	∞			
2525M08-80-200-T15	25	25	150	25.4	25	15	80	200			
2525M08-80-200-T30	25	25	150	25.4	25	32	80	200			
2525M08-80-200-T45	25	25	150	25.4	25	45	80	200			
2525M08-200-800-T15	25	25	150	25.4	25	15	200	800			
2525M08-200-800-T30	25	25	150	25.4	25	30	200	800			
2525M08-200-800-T45	25	25	150	25.4	25	45	200	800			
2525M08-200-800-T60	25	25	150	25.4	25	60	200	800			
2525M10-50-80-T15	25	25	150	25.4	25	15	50	∞	TIGER 100508	M4.0	T-15
2525M10-50-80-T30	25	25	150	25.4	25	30	50	∞			
2525M10-50-80-T45	25	25	150	25.4	25	45	50	∞			
2525M10-80-200-T15	25	25	150	25.4	25	15	80	200			
2525M10-80-200-T30	25	25	150	25.4	25	32	80	200			
2525M10-80-200-T45	25	25	150	25.4	25	45	80	200			
2525M10-200-800-T15	25	25	150	25.4	25	15	200	800			
2525M10-200-800-T30	25	25	150	25.4	25	30	200	800			
2525M10-200-800-T45	25	25	150	25.4	25	45	200	800			
2525M10-200-800-T60	25	25	150	25.4	25	60	200	800			
2525M12-50-80-T15	25	25	150	25.4	25	15	50	∞	TIGER 120508	M5.0	T-20
2525M12-50-80-T30	25	25	150	25.4	25	30	50	∞			
2525M12-50-80-T45	25	25	150	25.4	25	45	50	∞			
2525M12-80-200-T15	25	25	150	25.4	25	15	80	200			
2525M12-80-200-T30	25	25	150	25.4	25	32	80	200			
2525M12-80-200-T45	25	25	150	25.4	25	45	80	200			
2525M12-200-800-T15	25	25	150	25.4	25	15	200	800			
2525M12-200-800-T30	25	25	150	25.4	25	30	200	800			
2525M12-200-800-T45	25	25	150	25.4	25	45	200	800			
2525M12-200-800-T60	25	25	150	25.4	25	60	200	800			
3232P08-80-200-T15	32	32	170	32.4	32	15	80	200	TIGER 080508	M3.5	T-15
3232P08-80-200-T30	32	32	170	32.4	32	30	80	200			
3232P08-80-200-T45	32	32	170	32.4	32	45	80	200			
3232P08-200-1000-T20	32	32	170	32.4	32	20	200	1000			
3232P08-200-1000-T40	32	32	170	32.4	32	40	200	1000			
3232P08-200-1000-T60	32	32	170	32.4	32	60	200	1000			
3232P10-80-200-T15	32	32	170	32.4	32	15	80	200	TIGER 100508	M4.0	T-15
3232P10-80-200-T30	32	32	170	32.4	32	30	80	200			
3232P10-80-200-T45	32	32	170	32.4	32	45	80	200			
3232P10-200-1000-T20	32	32	170	32.4	32	20	200	1000			
3232P10-200-1000-T40	32	32	170	32.4	32	40	200	1000			
3232P10-200-1000-T60	32	32	170	32.4	32	60	200	1000			

型号 Model	外槽加工, 车削加工 External groove machining, Lathe machining									TIGER Screw NLJ	扳手 Wrench
	h	b	L	F	h1	T _{最大}	最小	最大			
3232P12-80-200-T15	32	32	170	32.4	32	15	80	200	TIGER 120508	M5.0	T-20
3232P12-80-200-T30	32	32	170	32.4	32	30	80	200			
3232P12-80-200-T45	32	32	170	32.4	32	45	80	200			
3232P12-200-1000-T20	32	32	170	32.4	32	20	200	1000			
3232P12-200-1000-T40	32	32	170	32.4	32	40	200	1000			
3232P12-200-1000-T60	32	32	170	32.4	32	60	200	1000			
4040R08-200-1000-T30	40	40	200	40.4	40	30	200	1000	TIGER 080508	M3.5	T-15
4040R08-200-1000-T50	40	40	200	40.4	40	50	200	1000			
4040R08-200-1000-T70	40	40	200	40.4	40	70	200	1000			
4040R10-200-1000-T30	40	40	200	40.4	40	30	200	1000	TIGER 100508	M4.0	T-15
4040R10-200-1000-T50	40	40	200	40.4	40	50	200	1000			
4040R10-200-1000-T70	40	40	200	40.4	40	70	200	1000			
4040R12-200-1000-T30	40	40	200	40.4	40	30	200	1000	TIGER 120508	M5.0	T-20
4040R12-200-1000-T50	40	40	200	40.4	40	50	200	1000			
4040R12-200-1000-T70	40	40	200	40.4	40	70	200	1000			
4040R12-200-1000-T70	40	40	200	40.4	40	70	200	1000			

MRWUR/L

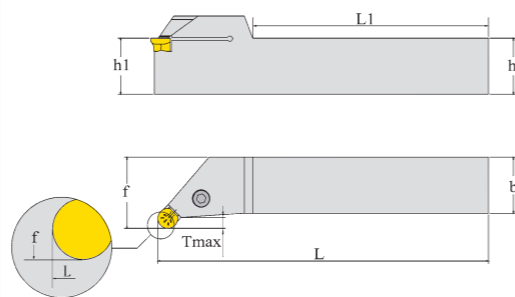

型号 Model		外槽加工, 车削加工 External groove machining, Lathe machining						 螺丝NLJ Screw NLJ	 扳手 Wrench
		h	b	L	L1	f	T _{最大} Max		
MRWUR/L	2020 K-3	20	20	125	90	23	3	MRMN300	NLJ0520 L4.0
	2525 M-3	25	25	150	115	28	3		
	3232 P-3	32	32	170	135	35	3		
	2020 K-4	20	20	125	90	23	3	MRMN400	
	2525 M-4	25	25	150	115	28	3		
	3232 P-4	32	32	170	135	35	3		
	2020 K-5	20	20	125	90	24	4	MRMN500	
	2525 M-5	25	25	150	115	29	4		
	3232 P-5	32	32	170	135	36	4		



此款割刀匹配的是克洛依、悍狮霸的刀片槽

MRNUR/L

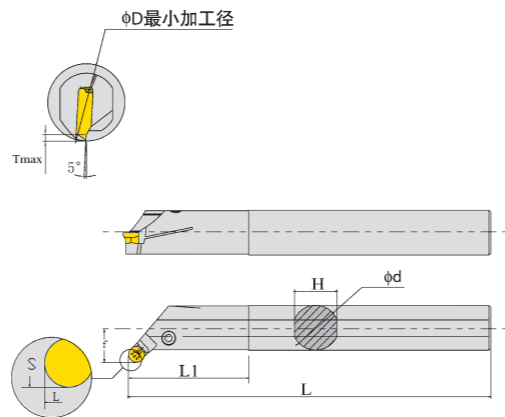
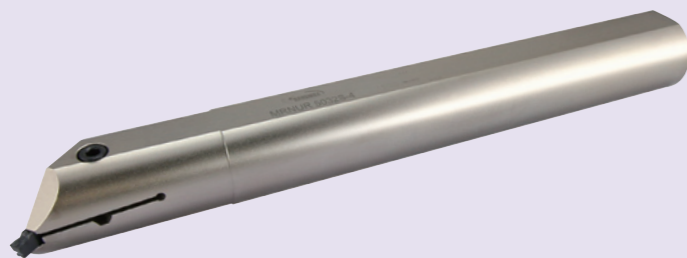

型号 Model		内槽加工, 车削加工 Internal groove machining, Lathe machining						 螺丝NLJ Screw NLJ	 扳手 Wrench
		D _{最小加工径} d	L	L1	H	T _{最大} Max	f		
MRNUR/L	3520 M-3	35	20	150	45	18	3.5	13	MGMN300
	4025 R-3	40	25	200	45	23	3.5	15.5	
	5032 S-3	50	32	250	65	30	3.5	19	
	3520 M-4	35	20	150	45	18	3.5	13	MGMN400
	4025 R-4	40	25	200	45	23	3.5	15.5	
	5032 S-4	50	32	250	65	30	3.5	19	
	3520 M-5	35	20	150	45	18	3.5	13	MGMN500
	4025 R-5	40	25	200	45	23	3.5	15.5	
	5032 S-5	50	32	250	65	30	3.5	19	

螺纹刀 THREAD CUTTER

目录

外螺纹刀(J01)



SER/L

外螺纹刀(J01)



SER/L-W

外螺纹刀(J02)



MER/L

外螺纹刀(J02)



B-SER/L

外螺纹刀(J03)



MTWHR/L

内螺纹刀(J03)



MNR/L

内螺纹刀(J04)



SNR/L

内螺纹刀(J04)



SNR/L 变杆

SER/L

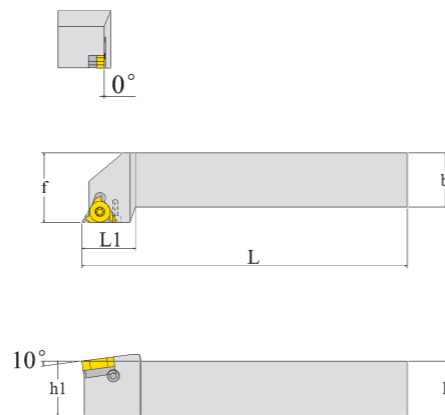

型号 Model		h	b	L	f	h1	L1	侧孔螺丝 NLJ	扳手 Wrench	垫片右 WLW	垫片左 WLW	螺丝 Screw	
SER/L	1012 H16	10	12	100	16	10	20	ER/L16	M3.5*12	T15	WLW16	NLW16	NLJ0308
	1212 H16	12	12	100	16	12	20						
	1616 H16	16	16	100	20	16	22						
	2020 K16	20	20	125	25	20	25						
	2525 M16	25	25	150	32	25	30						
	3232 P16	32	32	170	40	32	35						

MER/L

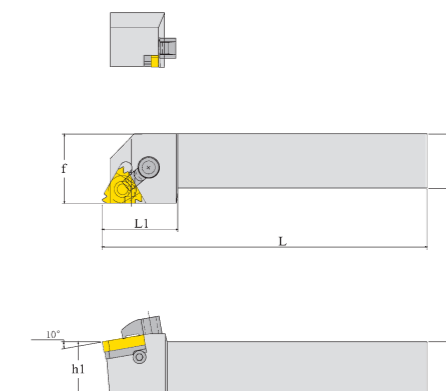

型号 Model		h	b	L	f	h1	L1	侧孔螺丝 NLJ	压板 MYB	双头螺丝 ST	扳手 Wrench	垫片右 WLW	垫片左 WLW	螺丝 Screw
MER/L	2525M22	25	25	150	32	25	35	22ER/L	MYB1814	ST0625	T15	WLW022	NLW022	M4*12
	3232P22	32	32	170	40	32	35							

SER/L-W

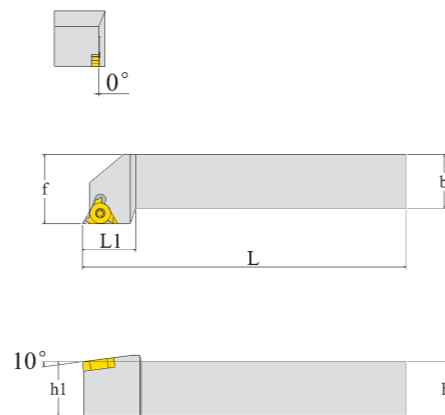

型号 Model		h	b	L	f	h1	L1	扳手 Wrench	螺丝 Screw
SER/L	1616 H16-W	16	16	100	20	16	22	T15	M3.5*8
	2020 K16-W	20	20	125	25	20	25		
	2525 M16-W	25	25	150	32	25	30		

B-SER/L

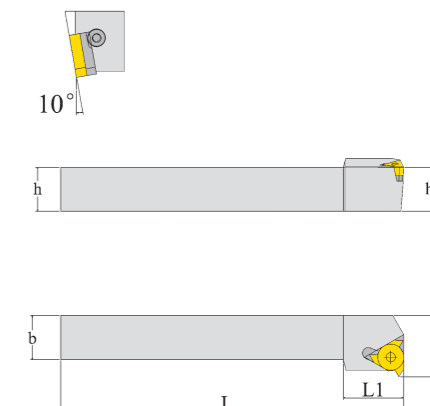

型号 Model		h	b	L	f	h1	L1	侧孔螺丝 NLJ	垫片右 WLW	垫片左 WLW	扳手 Wrench	螺丝 Screw
B-SER/L	1012 H16	10	12	100	16	10	20	ER/L16	WLW016	NLW016	T15	M3.5*12
	1212 K16	12	12	100	16	12	20					
	1616 K16	16	16	125	20	16	22					
	2020 K16	20	20	125	25	20	25					
	2525 M16	25	25	150	32	25	30					

MTWHR/L

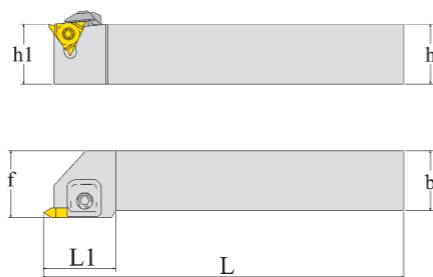

型号 Model	外槽加工, 车削加工						TT43	侧孔螺丝NLJ Side hole screw NLJ	扳手 Wrench	螺丝 Screw	压板MYB Pressing Plate MYB	弹簧DTH Spring DTH
	h	b	L	L1	H1	f						
MTWHR/L	1616 H-4	16	16	100	22	16	20					
	2020 K-4	20	20	125	28	20	25					
	2525 M-4	25	25	150	35	25	32					
	3232 P-4	32	32	170	35	32	40					

MNR/L

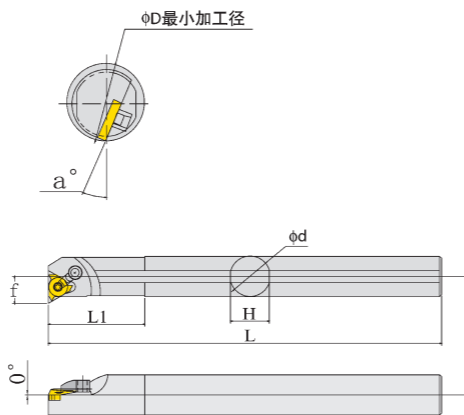

型号 Model	phi D	phi d	H	L	L1	f	a°	22NR/L	垫片右 WLW	垫片左 WLW	侧孔螺丝 NLJ	压板 MYB	双头螺丝 ST	螺丝 Screw	扳手 Wrench
	0032 S22	36	32	29	250	50	19.7	15							

SNR/L

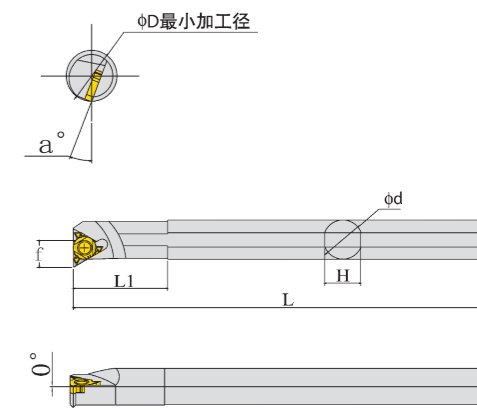

型号 Model	phi D	phi d	H	L	L1	f	a°	NR/L11	刀垫 Knife pad	螺丝 Screw	扳手 Wrench
	0012 M11	15	12	11	150	22	8.0	15		M2.5*6	T-8
	0013 M11	16	13	12	150	32	8.5	17			
	0016 M16	19	16	15	150	40	11.7	15		M3.5*8	T-15
	0016 Q16	19	16	15	180	40	11.7	15			
	0020 Q16	24	20	18	180	40	13.7	21			
	0025 R16	29	25	23	200	45	16.2	21			
	0032 S16	36	32	29	250	50	19.7	15			
	0010 K11-A	13	10	9	125	22	7.2	15		M2.5*6	T-8
	0012 M11-A	15	12	11	150	22	8.0	15			
	0016 M16-A	19	16	15	150	40	11.7	15		M3.5*8	T-15
	0016 Q16-A	19	16	15	180	40	11.7	15			
	0020 Q16-A	24	20	18	180	40	13.7	21			
	0025 R16-A	29	25	23	200	45	16.2	21			
	0032 S16-A	36	32	29	250	60	19.7	15	NLW016		
	0040 T16-A	44	40	37	300	60	23.7	21	WLW016		

SNR/L-变杆

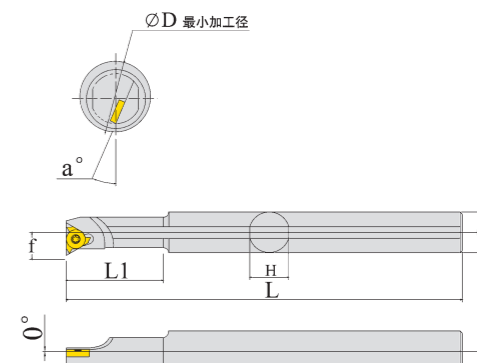

型号 Model	phi D	phi d	H	L	L1	f	a°	NR/L08	螺丝 Screw	扳手 Wrench	
											SNR/L
	0816M08	11	16	15	150	20	6.2	15			
	0916M08	12	16	15	150	23	6.7	15			
	1016M08	13	16	15	150	25	7.2	15			
	1016M11	13	16	15	150	22	7.7	15			
	1316M11	16	16	15	150	32	8.7	15		M2.5*6	T8
	1020M11	13	20	18	150	32	7.7	15			
	1316M16	16	16	15	150	32	8.7	15			
	1620M16	20	20	18	150	40	11.7	15	NR/L16	M3.5*10	T15

非标复合镗孔刀

Non-standard composite boring blade

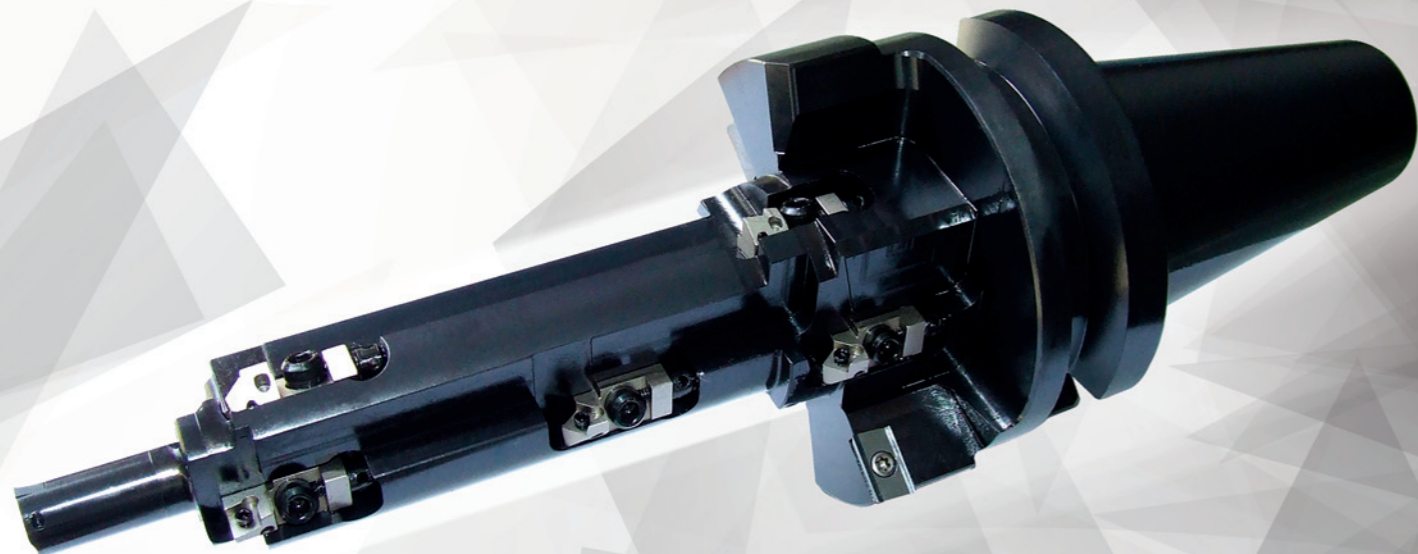

- 具有高效的切削性能，可进行多道工序加工（在根据工件加工特性设计下，可获得更好的切削速度）。
- 组合简单方便，采用组件连接，保护了刀体在加工过程中不被括伤、损坏、利于维护，从而获得更好的寿命。

High cutting properties applicable to multi-process machining (optimal cutting speed obtainable as per the characteristics of work pieces)

Simple combination and assembly characteristics ensure easy maintenance and safeguard cutter body from damage or scratch during the machining process with prolonged service life.

小刀夹、镗刀头、刀柄系列 Knife handle series boring head

目录

90° 刀夹(K1) SCF◇R/L	90° 刀夹(K1) SCG◇R/L	95° 刀夹(K2) SCL◇R/L	45° 刀夹(K2) S◇S◇R/L	75° 刀夹(K3) S◇KCR/L
40° 刀夹(K3) SCW◇R/L	90° 刀夹(K4) STFCR/L	90° 刀夹(K4) STGCR/L	30° 刀夹(K5) STTCR/L	60° 刀夹(K5) STWCR/L
90° 镗刀头(K6) TZC镗头	45° 镗刀头(K7) TQC镗头	镗刀头(K8) CBS替换式搪孔刀柄	镗刀头(K9) CBS-P替换式搪孔刀柄	镗刀头(K10) CBS-D替换式搪孔刀柄
镗刀头(K11) TBS替换式搪孔刀柄	精镗杆(K12) MBH2084精镗杆	精镗杆(K13) BJ16精镗杆	精镗杆(K13) BJ16合金防震精镗杆	刀柄(K14) 弹性筒夹刀柄
刀柄(K15) ER筒夹	刀柄(K15) ER螺帽	刀柄(K16) 强力刀柄	刀柄(K16) AC筒夹套	刀柄(K17) 面铣刀柄
刀柄(K18) 侧固式刀柄2	刀柄(K19) 90°粗镗刀柄	刀柄(K20) 45°粗镗刀柄	刀柄(K20) BT-拉钉	

SCF◇R/L

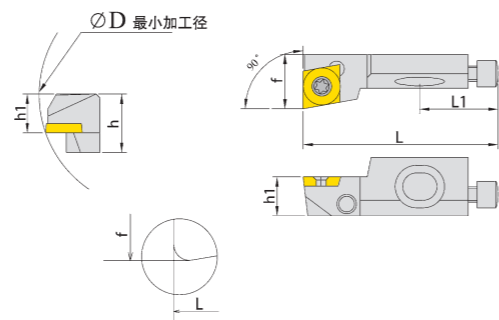

型号 Model		ØD	h	f	L	L1	h1	螺丝 Screw	螺丝GD Screw GD	螺丝TJLS Screw TJLS	螺丝DJ Screw DJ	扳手 Wrench
SCFPR/L 06CA-05	CP□□050204	20	8.5	8	25	12	6	M2.2*5	03510	03009	03006	T6
SCFCR/L 08CA-06	CC□□060204	25	10	10	32	17	8	M2.5*6	04016	04012	04008	T8
SCFCR/L 10CA-09	CC□□09T308	40	15	14	50	20	10	M3.5*8	06020	04012	04008	T15

SCL◇R/L

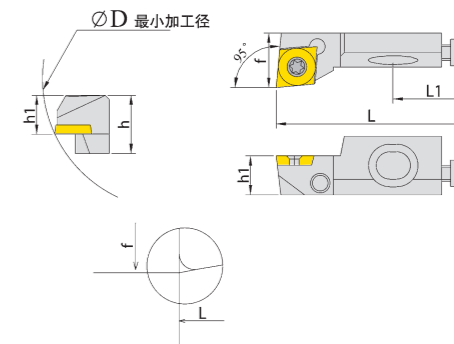

型号 Model		ØD	h	f	L	L1	h1	螺丝 Screw	螺丝GD Screw GD	螺丝TJLS Screw TJLS	螺丝DJ Screw DJ	扳手 Wrench
SCLPR/L 06CA-05	CP□□050204	20	8.5	8	25	12	6	M2.2*5	03510	03009	03006	T6
SCLCR/L 08CA-06	CC□□060204	25	10	10	32	17	8	M2.5*6	04016	04012	04008	T8
SCLCR/L 10CA-09	CC□□09T308	40	15	14	50	20	10	M3.5*8	06020	05014	04012	T15
SCLCR/L 12CA-12	CC□□120408	50	20	20	55	20	12	M5*12	06025	05014	04012	T20

SCG◇R/L

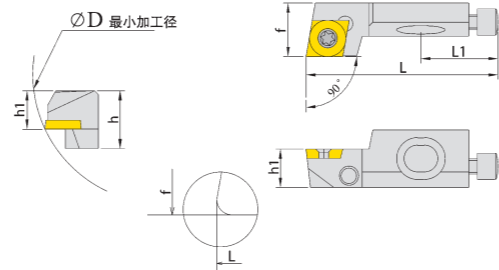

型号 Model		ØD	h	f	L	L1	h1	螺丝 Screw	螺丝GD Screw GD	螺丝TJLS Screw TJLS	螺丝DJ Screw DJ	扳手 Wrench
SCGPR/L 06CA-05	CP□□050204	20	8.5	8	25	12	6	M2.2*5	03510	03009	03006	T6
SCGCR/L 08CA-06	CC□□060204	25	10	10	32	17	8	M2.5*6	04016	04012	04008	T8
SCGCR/L 10CA-09	CC□□09T308	40	15	14	50	20	10	M3.5*8	06020	04012	04008	T15

S◇S◇R/L

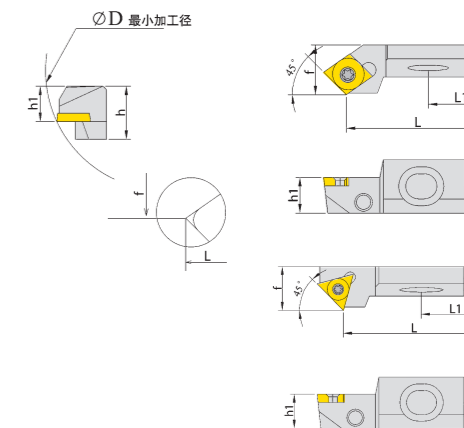

型号 Model		ØD	h	f	L	L1	h1	螺丝 Screw	螺丝GD Screw GD	螺丝TJLS Screw TJLS	螺丝DJ Screw DJ	扳手 Wrench
SCSPR/L 06CA-05	CP□□050204	20	8.5	8	21.4	12	6	M2.2*5	03510	03009	03006	T6
SCSCR/L 08CA-06	CC□□060204	25	10	10	28	17	8	M2.5*6	04016	04012	03006	T8
SCSCR/L 10CA-09	CC□□09T308	40	15	14	44	20	10	M3.5*8	06020	04012	04008	T15
STSCR/L 08CA-09	TC□□090204	25	10	10	33.5	17	8	M2.2*6	04016	04012	03006	T6
STSCR/L 10CA-11	TC□□110204	40	15	14	44	20	10	M2.5*6	06020	04012	04008	T8
STSCR/L 12CA-16	TC□□16T308	50	20	20	47	20	12	M3.5*8	06025	05014	04012	T15
STSCR/L 16CA-16		55	21	25	53	25	16	M3.5*8	08030	06019	04012	T15

S◇KCR/L

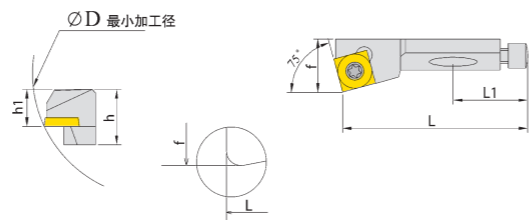

型号 Model		∅D	h	f	L	L1	h1	螺丝 Screw	螺丝GD Screw GD	螺丝TJLS Screw TJLS	螺丝DJ Screw DJ	扳手 Wrench
SCKCR/L 08CA-06	CC□□060204	25	10	10	32	17	8	M2.5*6	04016	04012	03006	T8
SSKCR/L 10CA-09	SC□□09T308	40	15	14	50	20	10	M3.5*8	06020		04008	T15
SSKCR/L 12CA-12	SC□□120408	50	20	20	55	20	12	06025	05014			
SSKCR/L 16CA-12		55	21	25	63	25	16	M5*12	08030	06019	04012	T20

STFCR/L

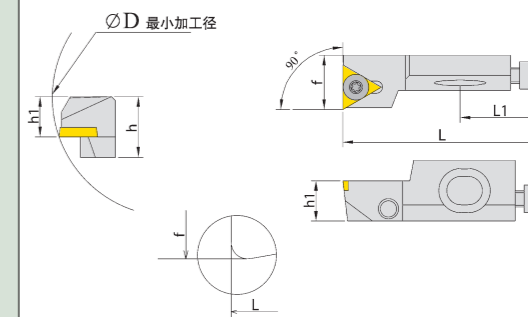

型号 Model		∅D	h	f	L	L1	h1	螺丝 Screw	螺丝GD Screw GD	螺丝TJLS Screw TJLS	螺丝DJ Screw DJ	扳手 Wrench
STFCR/L 08CA-09	TC□□090204	25	10	10	32	17	8	M2.5*6	04016	04012	03006	T8
STFCR/L 10CA-11	TC□□110204	40	15	14	50	20	10	M3.5*8	06020		04008	T15
STFCR/L 12CA-16	TC□□16T308	50	20	20	55	20	12		06025	05014		
STFCR/L 16CA-16		55	21	25	63	25	16	08030	06019	04012		

SCW◇R/L

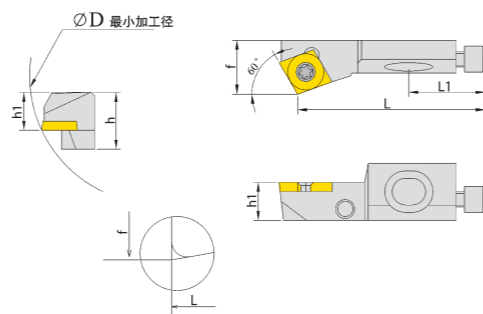
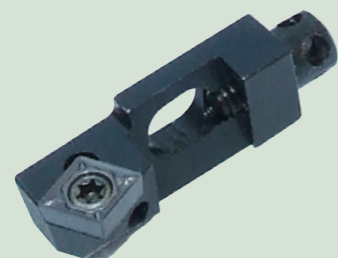

型号 Model		∅D	h	f	L	L1	h1	螺丝 Screw	螺丝GD Screw GD	螺丝TJLS Screw TJLS	螺丝DJ Screw DJ	扳手 Wrench
SCWPR/L 06CA-05	CP□□050204	20	8.5	8	22.7	12	6	M2.2*5	03510	03009	03006	T6
SCWCR/L 08CA-06	CC□□060204	25	10	10	29	17	8	M2.5*6	04016	04012	03006	T8

STGCR/L

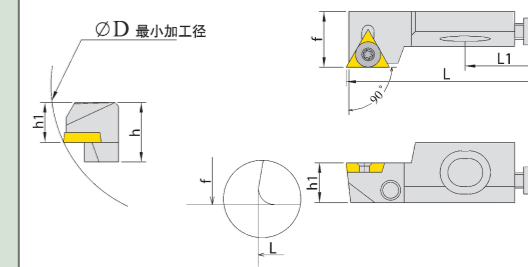
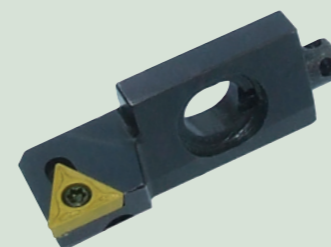

型号 Model		∅D	h	f	L	L1	h1	螺丝 Screw	螺丝GD Screw GD	螺丝TJLS Screw TJLS	螺丝DJ Screw DJ	扳手 Wrench
STGCR/L 08CA-09	TC□□090204	25	10	10	32	17	8	M2.5*6	04016	04012	03006	T8
STGCR/L 10CA-11	TC□□110204	40	15	14	50	20	10		06020		04008	
STGCR/L 12CA-16	TC□□16T308	50	20	20	55	20	12	M3.5*8	06025	05014		T15
STGCR/L 16CA-16		55	21	25	63	25	16		08030	06019	04012	

STTCR/L

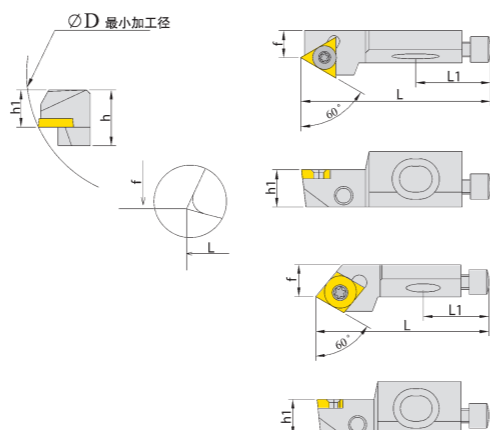

型号 Model		∅D	h	f	L	L1	h1	螺丝 Screw	螺丝GD Screw GD	螺丝TJLS Screw TJLS	螺丝DJ Screw DJ	扳手 Wrench
STTCR/L 10CA-11	TC□□110204	40	15	9	50	20	10	M2.5*6	06020	04012	04008	T8
STTCR/L 12CA-16	TC□□16T308	50	20	13	55	20	12	M3.5*8	06025	05014	04012	T15
STTCR/L 16CA-16	TC□□16T308	55	21	15	63	25	16	M3.5*8	08030	06019	04012	T15
SCTPR/L 06CA-05	CP□□050204	20	8.5	5.5	25	12	6	M2.2*5	03510	03009	03006	T6
SCTCR/L 08CA-06	CC□□060204	25	10	6	32	17	8	M2.5*6	04016	04012	03006	T8

STWCR/L

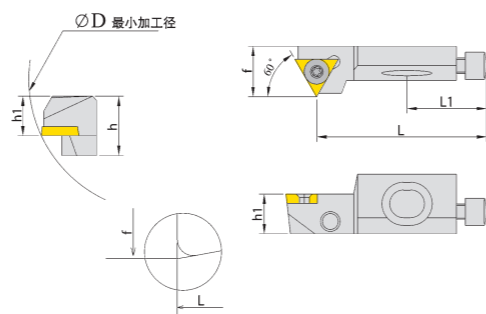

型号 Model		∅D	h	f	L	L1	h1	螺丝 Screw	螺丝GD Screw GD	螺丝TJLS Screw TJLS	螺丝DJ Screw DJ	扳手 Wrench
STWCR/L 10CA-11	TC□□110204	40	15	14	44	20	10	M2.5*6	06020	04012	04008	T8
STWCR/L 12CA-16	TC□□16T308	50	20	20	47	20	12	M3.5*8	06025	05014	04012	T15
STWCR/L 16CA-16	TC□□16T308	55	21	25	53	25	16	M3.5*8	08030	06019	04012	T15

TZC 镗头 Boring head

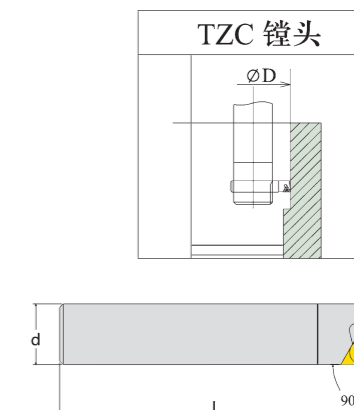

型号 Model		∅D 镗孔径范围 Range of pore size	L	d	螺丝 Screw	扳手 Wrench
TZC08-23-90-L	TC◇◇090204	25-38	23	8	M2.2*5 M2.5*6小帽	T-8
TZC08-36-90-L	TC◇◇090204	38-50	36	10		
TZC10-48-90-L	TC◇◇090204	50-70	48	13		
TZC13-48-90-L	TC◇◇110204	70-90	65	16		
TZC13-65-90-L	TC◇◇110204	62-90	60	19	M3.5*8	T-15
TZC16-60-90-L	TC◇◇110204	90-115	85	25		
TZC16-85-90-L	TC◇◇110204	72-105	70	19		
TZC19-70-90-L	TC◇◇16T308	105-135	95	120		
TZC19-95-90-L	TC◇◇16T308	135-150	120	100		
TZC19-120-90-L	TC◇◇16T308	105-140	100	135		
TZC25-100-90-L	TC◇◇16T308	140-190	135			

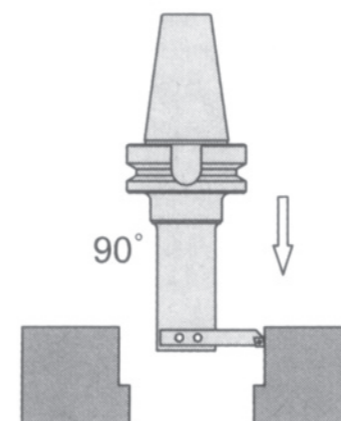

TQC 镗头 Boring head

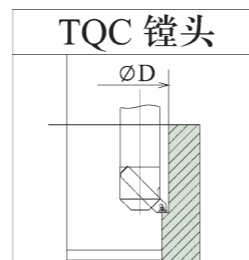
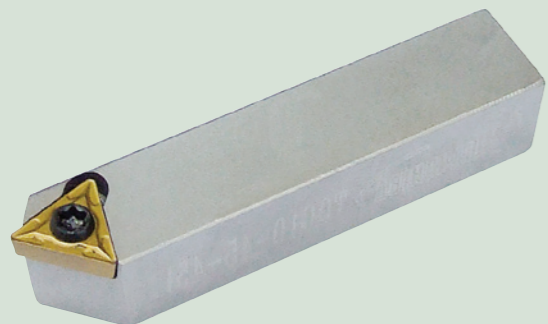

型号 Model		$\varnothing D$ 镗孔直径范围 Range of pore size	L	d	螺丝 Screw	扳手 Wrench
TQC 08-29-45-L	TC◇◇090204	25-38	29	8	M2.2*5 M2.5*6小帽	T-8
TQC 08-45-45-L		38-50	45			
TQC 10-45-45-L	TC◇◇090204			10		
TQC 10-60-45-L		50-70	60	13		
TQC 13-60-45-L	TC◇◇110204	70-90	81	13		
TQC 13-81-45-L		62-90	75	16	M3.5*8	T-15
TQC 16-75-45-L	TC◇◇110204	90-115	106	16		
TQC 16-106-45-L		72-105	88	19		
TQC 19-88-45-L	TC◇◇16T308	105-135	119	19		
TQC 19-119-45-L		105-140	125	25		
TQC 25-125-45-L	TC◇◇16T308	140-190	169	25		

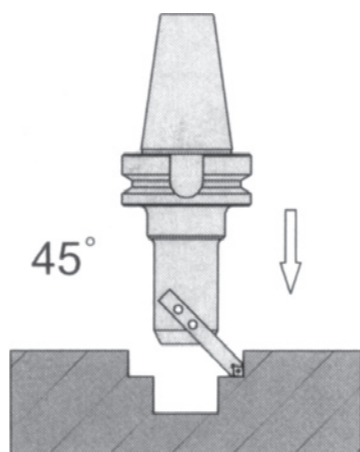

CBS 替换式搪孔刀柄 CBS Interchangeable boring cutter



示意图 Schematic diagram	型号 Model		h	h1	L	d	K	螺丝 Screw	扳手 Wrench
	CBS-308	CCMT0602	8	8	55	8	30°	M2.5*6	T8
	CBS-310		10	10	65	10			
	CBS-313	CCMT09T3	13	13	80	13			
	CBS-316		16	16	120	16			
	CBS-319	CCMT1204	19	19	140	19			
CBS-325		25	25	150	25	M5*12	T20		
	CBS-408	CCMT0602	8	8	55	8	45°	M2.5*6	T8
	CBS-410		10	10	65	10			
	CBS-413	CCMT09T3	13	13	80	13			
	CBS-416		16	16	120	16			
	CBS-419	CCMT1204	19	19	140	19		M5*12	T20
CBS-425		25	25	150	25	M5*12	T20		
	CBS-908	CCMT0602	8	8	55	8	90°	M2.5*6	T8
	CBS-910		10	10	65	10			
	CBS-913	CCMT09T3	13	13	80	13			
	CBS-916		16	16	120	16			
	CBS-919	CCMT1204	19	19	140	19		M5*12	T20
CBS-925		25	25	150	25	M5*12	T20		



CBS-P 替换式搪孔刀柄 CBS-P Interchangeable boring cutter

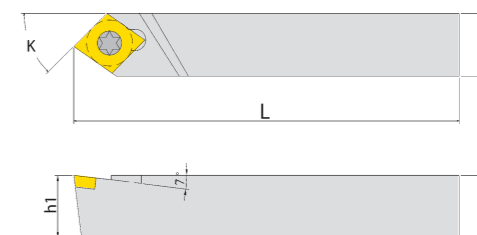
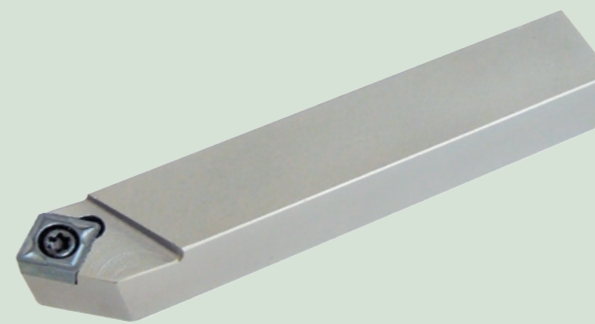
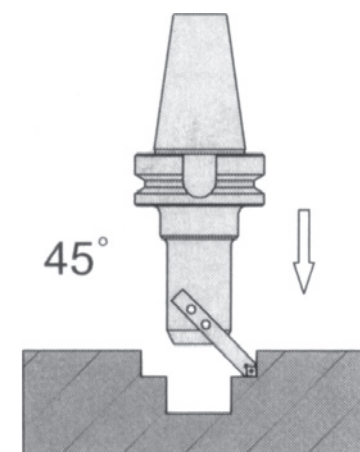

示意图 Schematic diagram	型号 Model		h	h1	L	d	K	螺丝	扳手
								Screw	Wrench
	CBS-308-P	CCMT0602	8	8	55	8	30°	M2.5*6	T8
	CBS-310-P		10	10	65	10		M3.5*8	T15
	CBS-313-P	13	13	80	13	M5*12		T20	
	CBS-316-P	16	16	120	16				
	CBS-319-P	19	19	140	19				
	CBS-325-P	25	25	150	25				
	CBS-408-P	CCMT0602	8	8	55	8	45°	M2.5*6	T8
	CBS-410-P		10	10	65	10		M3.5*8	T15
	CBS-413-P	13	13	80	13	M5*12		T20	
	CBS-416-P	16	16	120	16				
	CBS-419-P	19	19	140	19				
	CBS-425-P	25	25	150	25				
	CBS-908-P	CCMT0602	8	8	55	8	90°	M2.5*6	T8
	CBS-910-P		10	10	65	10		M3.5*8	T15
	CBS-913-P	13	13	80	13	M5*12		T20	
	CBS-916-P	16	16	120	16				
	CBS-919-P	19	19	140	19				
	CBS-925-P	25	25	150	25				

小刀夹 镗刀头 刀柄系列 Knife handle series boring head

K

CBS-D 替换式搪孔刀柄 CBS-D Interchangeable boring cutter

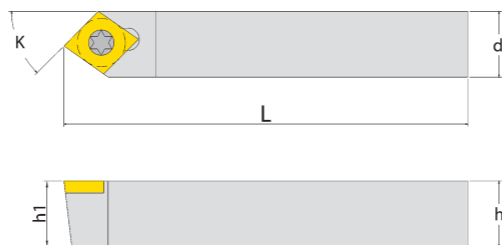
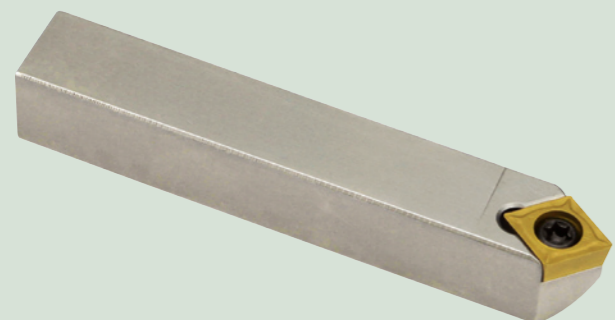

示意图 Schematic diagram	型号 Model		h	h1	L	d	K	螺丝	扳手
								Screw	Wrench
	CBS-308-D	CCMT0602	8	6	55	8	30°	M2.5*6	T8
	CBS-310-D		10	7	65	10		M3.5*8	T15
	CBS-313-D	13	10	80	13	M5*12		T20	
	CBS-316-D	16	11	120	16				
	CBS-319-D	19	13	140	19				
	CBS-325-D	25	18	150	25				
	CBS-408-D	CCMT0602	8	6	55	8	45°	M2.5*6	T8
	CBS-410-D		10	7	65	10		M3.5*8	T15
	CBS-413-D	13	10	80	13	M5*12		T20	
	CBS-416-D	16	11	120	16				
	CBS-419-D	19	13	140	19				
	CBS-425-D	25	18	150	25				
	CBS-908-D	CCMT0602	8	6	55	8	90°	M2.5*6	T8
	CBS-910-D		10	7	65	10		M3.5*8	T15
	CBS-913-D	13	10	80	13	M5*12		T20	
	CBS-916-D	16	11	120	16				
	CBS-919-D	19	13	140	19				
	CBS-925-D	25	18	150	25				

小刀夹 镗刀头 刀柄系列 Knife handle series boring head

K

TBS 替换式搪孔刀 TBS Interchangeable boring cutter

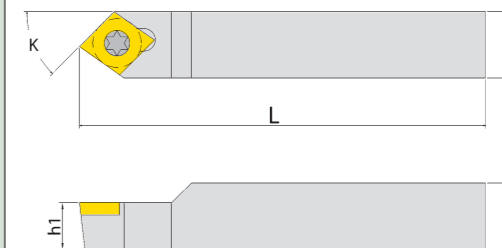
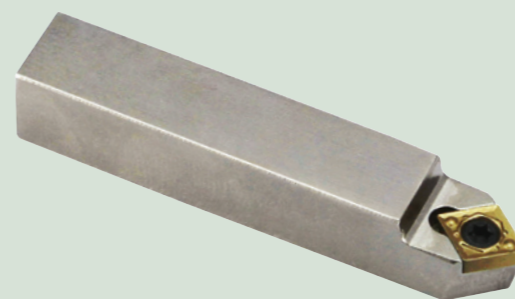

示意图 Schematic diagram	型号 Model		h	h1	L	d	K	螺丝 Screw	扳手 Wrench
	TB(P)S-308	TC(P)GH090204	8	8	55	8	30°	M2.2*5	T8
	TB(P)S-310		10	10	65	10			
	TB(P)S-313	TC(P)GH110304	13	13	80	13		M2.5*6小帽	
	TB(P)S-316		16	16	120	16			
	TB(P)S-319	TC(P)GH160304	19	19	140	19		M3.5*8	
TB(P)S-325	25		25	150	25				
	TB(P)S-408	TC(P)GH090204	8	8	55	8	45°	M2.5*6	T8
	TB(P)S-410		10	10	65	10			
	TB(P)S-413	TC(P)GH110304	13	13	80	13		M3.5*8	
	TB(P)S-416		16	16	120	16			
	TB(P)S-419	TC(P)GH160304	19	19	140	19		T15	
TB(P)S-425	25		25	150	25				
	TB(P)S-908	TC(P)GH090204	8	8	55	8	90°	M2.5*6	T8
	TB(P)S-910		10	10	65	10			
	TB(P)S-913	TC(P)GH110304	13	13	80	13		M3.5*8	
	TB(P)S-916		16	16	120	16			
	TB(P)S-919	TC(P)GH160304	19	19	140	19		T15	
TB(P)S-925	25		25	150	25				

MBH2084 精镗杆 MBH2084 Fine boring bar

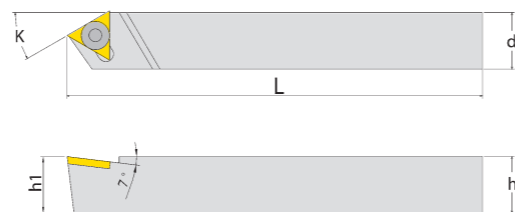
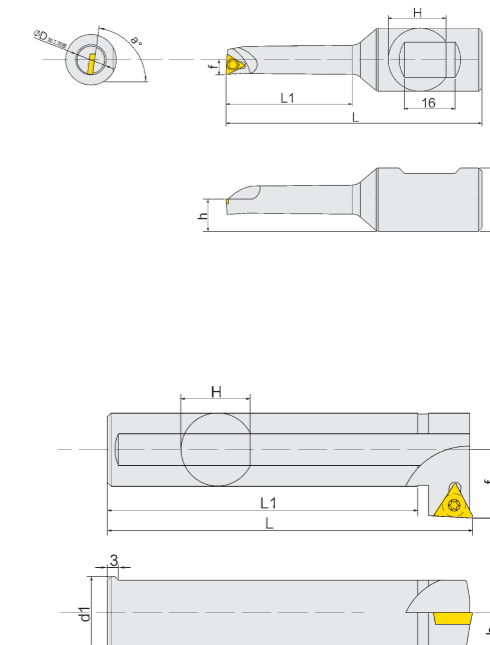
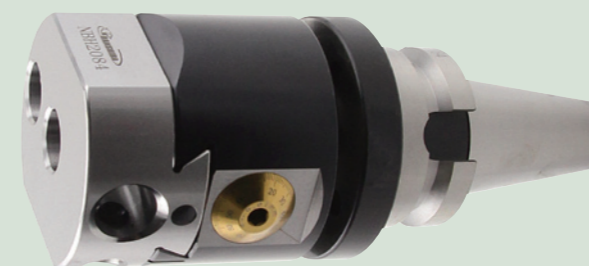

型号 Model		∅D加工范围	L	L1	d1	h	H	a°	螺丝 Screw	扳手 Wrench
BJ2008-32	TB□□0601	8-11	74	32	20	10.2	15	8	M2*5	T6
BJ2010-40		10-13	81	40						
BJ2012-53	TP□□0902	12-17	92	53	20	10.5	15	⊗	M2.5*6	T8
BJ2016-68		16-21	104	68						
BJ2020-83	TP□□1103	20-130	117	83	20	10.5	15	⊗	M3*8	T8
BJ2025-96		25-135	130	96						
BJ2030-115		30-140	149	115						
BJ2020-L		120-280	84	84						
● 加长型										
BJ2020-120	TP□□1103	20-130	154	120	20	10.5	15	⊗	M3*8	T8
BJ2020-150		20-130	184	150						
BJ2025-120		25-135	154	120						
BJ2025-150		25-135	184	150						
BJ2030-150		30-140	184	150						

BJ16 精镗杆 BJ16 Fine boring bar

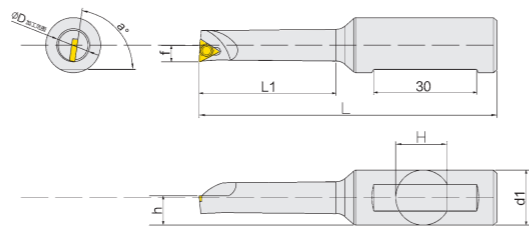

型号 Model		∅D加工范围	L	L1	d1	h	H	a°	螺丝 Screw	扳手 Wrench
BJ1606-24	WB□□0301	6-9	73	24	16	8.5	15	8	M2+5	T6
BJ1608-32	TB□□0601	8-11	80	32						
BJ1610-40		10-13	87	40						
BJ1612-53		TP□□0902	12-17	98						
BJ1616-68	16-21		110	68						
BJ1620-83	20-26		121	83						
BJ1625-90	TP□□1103		25-31	128						
BJ1630-90		30-36	128	90						
BJ1614-60(增加型号)		TP□□0902	14-19	103						
● 加长型										
BJ1616-120	TP□□0902	16-21	162	120	16	8.5	15	⊗	M2.5*6	T8
BJ1616-150		16-21	192	150						
BJ1620-120	TP□□1103	20-26	158	120						
BJ1620-150		20-26	188	150						
BJ1625-120		25-31	158	120						
BJ1625-150		25-31	188	150						
BJ1630-120		30-36	158	120						
BJ1630-150	30-36	188	150							

BJ16 合金防震精镗杆 BJ16 Alloy shock proof boring bar

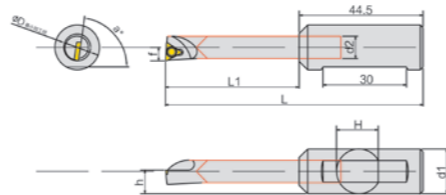
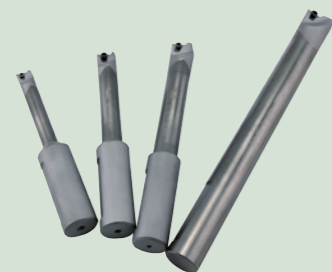

型号 Model		∅D加工范围	L	L1	d1	d2	h	H	a°	螺丝 Screw	扳手 Wrench
BJ1606-30-WG	WB□□0301	6	74.5	30	16	5	8.5	15	8	M2+5	T6
BJ1606-45-WG		6	89.5	45							
BJ1608-36-WG		8	80.5	36							
BJ1608-55-WG	TB□□0601	8	109.5	55							
BJ1610-48-WG		10	92.5	48							
BJ1610-75-WG	10	119.5	75								
BJ1612-60-WG	TP□□0902	12	100.5	60							
BJ1612-90-WG		12	130.5	90							
BJ1614-72-WG		14	116.5	72							
BJ1614-105-WG		14	149.5	105							
BJ1614-130-WG		14	174.5	130							
BJ1618-95-WG	TP□□1103	18	135	95	16	16	16	⊗	M3*8	T8	
BJ1618-120-WG		18	160	120							
BJ1618-150-WG		18	190	150							

弹性筒夹刀柄 COLLER CHUCK

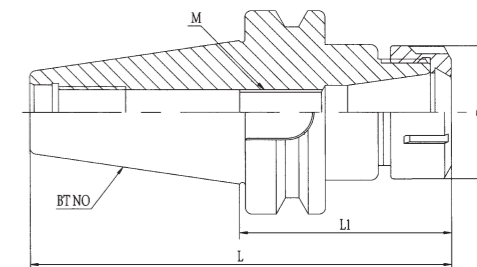

规格 MODEL NO	夹持范围 CAPACITY	L	L1	D	筒夹 PAGE 86	螺帽 PAGE 90	扳手 PAGE 86	
BT30	-ER11-60	0.5-7	108.4	60	19	ER11	ER11-A	OW/ER11
	-100		148.4	100	19			
	-ER16-60	1-10	108.4	60	28	ER16	ER16-A	OW/ER16
			-100	148.4	100			
	-ER20-60	2-13	108.4	60	34	ER20	ER20-A	OW/ER20
			-100	148.4	100			
	-ER25-60	2-16	108.4	60	42	ER25	ER25-UM	UM/ER25
			-100	148.4	100			
	-ER32-60	3-20	108.4	60	50	ER32	ER32-UM	UM/ER11
			-100	148.4	100			
BT40	-ER11-70	0.5-7	135.4	70	19	ER11	ER11-A	OW/ER11
	-100		165.4	100	19			
	-ER16-70	1-10	135.4	70	28	ER16	ER16-A	OW/ER16
			-100	165.4	100			
	-ER20-70	2-13	135.4	70	34	ER20	ER20-A	OW/ER20
			-100	165.4	100			
	-ER25-70	2-16	135.4	70	42	ER25	ER25-UM	UM/ER25
			-100	165.4	100			
	-ER32-70	3-20	135.4	70	50	ER32	ER32-UM	UM/ER32
			-100	165.4	100			
-ER40-80	3-26	145.4	70	63	ER40	ER40-UM	UM/ER40	
		-100	165.4	100				63
-ER16-70	1-10	171.8	70	28	ER16	ER16-A	OW/ER16	
		-100	201.8	100				28
-ER20-70	2-13	171.8	70	34	ER20	ER20-A	OW/ER20	
		-100	201.8	100				34
-ER25-70	2-16	171.8	70	42	ER25	ER25-UM	UM/ER25	
		-100	201.8	100				42
-ER32-70	3-20	171.8	70	50	ER32	ER32-UM	UM/ER32	
		-100	201.8	100				50
-ER40-80	3-26	181.8	80	63	ER40	ER40-UM	UM/ER40	
		-100	201.8	100				63
-150		251.8	150	63				
		-200	301.8	200				63

ER筒夹 ER COLLET

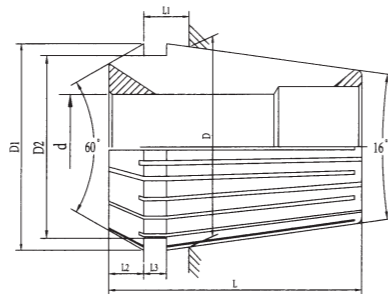

规格 MODEL NO	DH7	D	D1	D2	L	L1	L2	L3	弹性收缩量 Elastic shrinkage
ER8	1.0-5.0	8	8.45	6.5	13.5	2.98	1.5	1.2	0.5
ER11	1.0-7.0	11	11.5	9.5	18	3.8	2.5	2	0.5
ER16	1.0-2.5	16	17	13.8	27.5	27.5	4	2.7	0.5
	2.5-10.0	16	17	13.8	27.5	27.5	4	2.7	1
ER20	1.0-2.5	20	21	17.4	31.5	31.5	4.8	2.8	0.5
	2.5-13.0	20	21	17.4	31.5	31.5	4.8	2.8	1
ER25	1.0-2.5	25	26	22	34	34	5	3.1	0.5
	2.5-16.0	25	26	22	34	34	5	3.1	1
ER32	2.0-2.5	32	33	29.2	40	40	5.5	3.6	0.5
	2.5-20.0	32	33	29.2	40	40	5.5	3.6	1
ER40	3.0-26.0	40	41	36.2	46	46	7	4.1	1
ER50	6.0-10.0	50	52	46	60	60	8.5	5.5	1
	10.0-34.0	50	52	46	60	60	8.5	5.5	2

ER螺帽 ER NUT

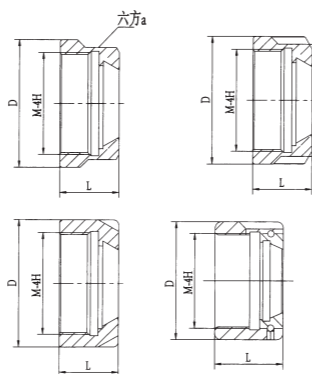

规格 MODEL NO	型式 Type	M	D	L
ER11-A	Fig.1	M14x0.75	19	13
ER16-A	Fig.1	M22x1.52	28	17.5
ER20-A	Fig.1	M25x1.5	34	19
ER25-UM	Fig.2	M32x1.5	42	20
ER32-UM	Fig.2	M40x1.5	50	22.5
ER40-UM	Fig.2	M50x1.5	63	29
ER8-M	Fig.3	M10x0.75	12	12
ER11-M	Fig.3	M13x0.75	16	12
ER16-M	Fig.3	M19x1	22	18
ER20-M	Fig.3	M24x1	28	19
ER25-M	Fig.3	M30x1	35	20
ER25-KM	Fig.4	M32x1.5	42	20
ER32-KM	Fig.4	M40x1.5	50	22.5
ER40-KM	Fig.4	M50x1.5	63	29

强力刀柄 MILLING CHUCK

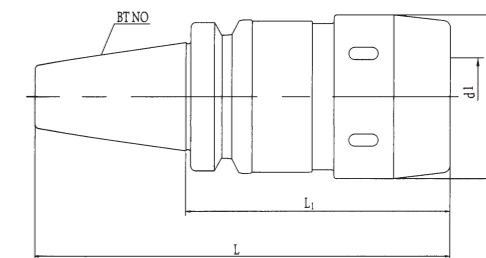

规格 MODEL NO	L	L1	d	d1	筒夹COLLET PAGE95
BT40	-C25-105	164.4	105	58	C25
	-C32-105	164.4	105	68	C32
BT50	-C25-105	200.8	105	58	C25
	-C32-105	200.8	105	68	C32
	-C42-105	200.8	105	84	C42

AC筒夹套 AC MILLING CHUCK



型号说明:

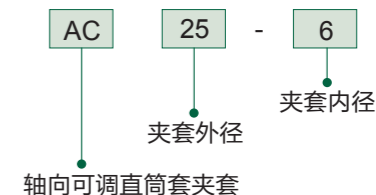

型号 MODEL	规格 MODEL NO
AC25	6, 8, 10, 12, 16, 20
AC32	6, 8, 10, 12, 16, 20, 25
AC42	6, 8, 10, 12, 16, 20, 25, 32

面铣刀柄 FACE MILL HOLDER

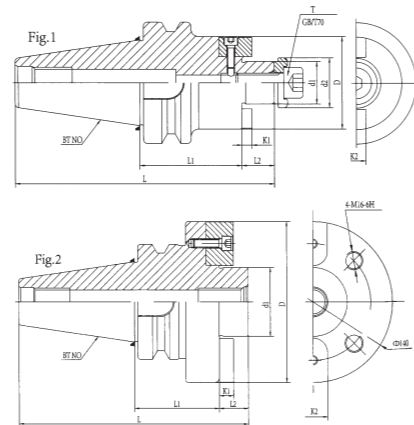

规格 MODEL NO	型式 TYPE	d1	d2	D	L	L1	L2	K1	K2	T									
BT30	-FMB22-45	Fig.1	22	26	45	109.9	45	16.5	4.8	10	M10x30								
	-60					124.9	60												
	-FMB27-45	Fig.1	27	33	54	111.9	45	18.5	5.8	12	M12x30								
	-60					126.9	60												
-FMB32-60	Fig.1	32	41	58	130.4	60	22	6.8	14	M16x35									
BT40	-FMB22-45	Fig.1	22	26	48	126.9	45	16.5	4.8	10	M10x30								
	-60					141.9	60												
	-100					181.9	100												
	-150					231.9	150												
	-FMB27-45					Fig.1	27					33	60	128.9	45	18.5	5.8	12	M12x30
	-60													143.9	60				
	-100	183.9	100																
	-150	233.9	150																
	-200	283.9	200																
	-FMB32-60	Fig.1	32	41	62			147.9	60	22	6.8			14	M16x35				
	-100					187.4	100												
	-150					237.4	150												
-200	287.4					200													
-FMB40-60	Fig.1					40	48	80	150.4			60	25			8	16	M16x35	
-100									190.4			100							
-150		240.4	150																
-200		290.4	200																
BT50		-FMB22-60	Fig.1	22	26				48	178.3	60	16.5		4.8	10				M10x30
		-100								218.3	100								
	-150	268.3				150													
	-200	318.3				200													
	-FMB27-60	Fig.1	27	33	60	180.3	60	18.5	5.8	12	M12x30								
	-100					220.3	100												
	-150					270.3	150												
	-200					320.3	200												
	-FMB32-60	Fig.1	32	41	73	183.8	60	22	6.8	14	M16x35								
	-100					223.8	100												
	-150					273.8	150												
	-200					323.8	200												
-FMB40-60	Fig.1	40	48	80	186.8	60	25	8	16	M16x35									
-100					226.8	100													
-150					276.8	150													
-200					326.8	200													
-FMB60-75	Fig.2	60	-	140	201.8	75	25	12.5	25.4	-									
-100					226.8	100													

侧固式刀柄2 SLN SIDE LOCK END MILL HOLDER

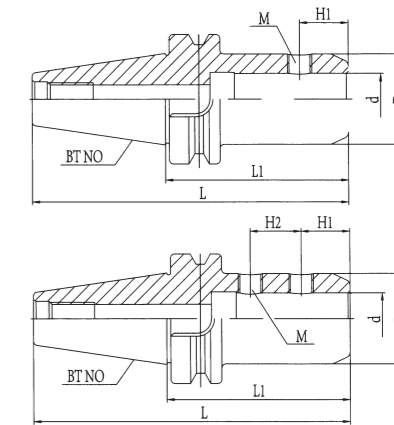

规格 MODEL NO	型式 TYPE	L	L1	H1	H2	M	D	d	
BT30	-SLN6-60	108.4	60	18	/	M6	25	6	
	-SLN8-60					20	M8	28	8
	-SLN10-60			22.5			M10	35	10
	-SLN12-60					24	M12	42	12
	-SLN16-75	123.4	75	25		M14	48	16	
	-SLN20-63	111.4	63	25		M16	52	20	
	-SLN20-75	123.4	75	24		25	M18	65	25
	-SLN25-80	128.4	80	24					
	-SLN25-90	138.4	90	24		25	M18	65	25
	-SLN25-100	148.4	100	24					
BT40	-SLN6-50	115.4	50	18	/	M6	25	6	
	-SLN8-50					20	M8	28	8
	-SLN10-63			22.5			M10	35	10
	-SLN12-63					24	M12	42	12
	-SLN16-63	128.4	63	25		M14	48	16	
	-SLN20-63	155.4	90	24		25	M18	65	25
	-SLN25-90	165.4	100	24					
	-SLN32-100	170.4	105	30		28	M20	72	32
	-SLN40-105	170.4	105	30		32		80	40
	-SLN42-105							82	42
BT50	-SLN6-63	164.8	63	18	/	M6	25	6	
	-SLN8-63					20	M8	28	8
	-SLN10-63			22.5			M10	35	10
	-SLN12-80					24	M12	42	12
	-SLN16-80	181.8	80	25		M14	48	16	
	-SLN20-80	201.8	100	24		25	M18	65	25
	-SLN25-100	206.8	105	24					
	-SLN32-105	216.8	115	30		28	M20	72	32
	-SLN40-115	216.8	115	30		32		80	40
	-SLN42-100							221.8	120

90° 粗镗刀柄 90° BSA BORING BAR

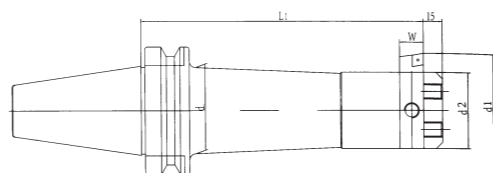
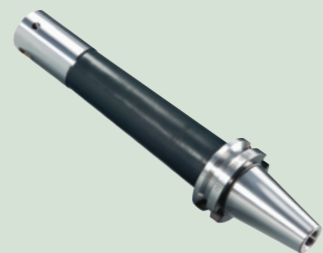

规格 MODEL NO	d1		d2	d3	L3	W
	最小加工径Min	最大加工径Max				
BT40-BSB25-120	25	52	20	22	120	8
BT40-BSB38-150	38	70	30	33	150	10
BT40-BSB50-165	50	90	34	44	165	13
BT40-BSB62-180	62	115	50	56	180	16
BT40-BSB90-180	90	150	75	62	180	19
BT50-BSB25-135	25	52	20	22	135	8
BT50-BSB38-180	38	70	30	32	180	10
BT50-BSB50-180	50	90	40	44	180	13
BT50-BSB50-240	50	90	40	44	240	13
BT50-BSB62-195	62	115	50	56	195	16
BT50-BSB62-270	62	115	50	56	270	16
BT50-BSB72-195	72	135	60	66	195	19
BT50-BSB72-285	72	135	60	66	285	19
BT50-BSB90-210	90	150	75	80	210	19
BT50-BSB90-300	90	150	75	80	300	19
BT50-BSB105-195	105	190	90	88	195	25
BT50-BSB105-285	105	190	90	94	285	25
BT50-BSB130-255	130	260	110	99	255	25

小刀夹 镗刀头 刀柄系列 knife handle series boring head

K

45° 粗镗刀柄 45° BSA BORING BAR

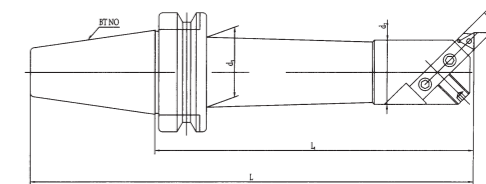

规格 MODEL NO	d1		d2	d3	L1	L	W
	最小加工径Min	最大加工径Max					
BT40-BSA25-120	25	38	20	22	120	185.4	8
BT40-BSA30-150	30	42	24	26	150	215.4	8
BT40-BSA38-165	38	52	30	33	165	230.4	10
BT40-BSA42-165	42	56	34	37	165	230.4	10
BT40-BSA50-120	50	65	40	44	165	230.4	13
BT40-BSA62-120	62	90	50	56	180	245.4	16
BT40-BSA72-120	72	110	60	62	180	245.4	19
BT40-BSA90-120	90	125	75	62	180	245.4	19
BT50-BSA25-135	25	38	20	22	135	236.8	8
BT50-BSA30-165	30	42	24	26	165	266.8	8
BT50-BSA38-180	38	52	30	33	180	281.8	10
BT50-BSA42-210	42	56	34	37	210	311.8	10
BT50-BSA50-180	50	65	40	44	180	281.8	13
BT50-BSA50-240	50	65	40	44	240	341.8	13
BT50-BSA62-195	62	90	50	56	195	296.8	16
BT50-BSA62-270	62	90	50	56	270	371.8	16
BT50-BSA72-195	72	110	60	66	195	296.8	19
BT50-BSA72-285	72	110	60	66	285	386.8	19
BT50-BSA90-210	90	125	75	80	210	311.8	19
BT50-BSA90-300	90	125	75	80	300	401.8	19
BT50-BSA105-195	105	160	90	88	195	296.8	25
BT50-BSA105-285	105	160	90	94	285	386.8	25
BT50-BSA130-255	130	190	110	99	255	356.8	25

小刀夹 镗刀头 刀柄系列 knife handle series boring head

K

BT-拉钉 BT PULL STUD

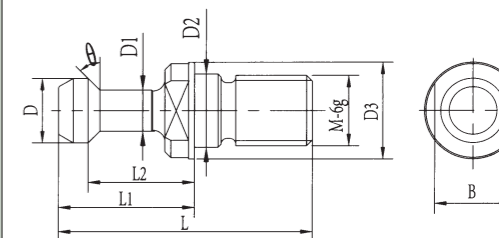

规格 MODEL NO	L	L1	L2	D	D1	D2	D3	M	θ
BT30	42	23	18	11	7	12.5	16.5	M12	45°/60°/90°
BT40	60	35	28	15	10	17	23	M16	45°/60°/90°
BT50	85	45	35	23	17	25	38	M24	45°/60°/90°

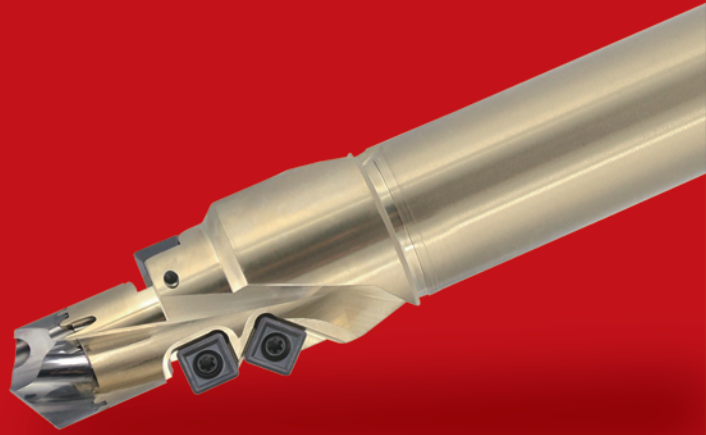

联系我们

中国智造：江苏悍狮霸智能科技有限公司
地 址：常州武进区马杭凌道工业园东昇路 11 号
销售电话：QQ003：2245839917 QQ001：2860864119
电话：18019691515
QQ008：1760666308 电话：18052703535
QQ007：3368819107 电话：18052514882
订制非标 QQ：1061147788
销售传真：0519-81980777
网 址：www.hsbsk.com
E-mail:2860864119@qq.com 1760666308@qq.com

Contact us

Manufacturer: Jiangsu Hanshiba Intelligent Technology Co., Ltd
Address : No.11 Dongsheng Road Lingdao Industrial Park, Ma Hang,
wujin, Changzhou City
Sales Tel : QQ003 : 2245839917 QQ001 : 2860864119
TEL : 18019691515
QQ008 : 1760666308 TEL : 18052703535
QQ007 : 3368819107 TEL : 18052514882
Non-standard QQ : 1061147788
Sales Fax : 0086-0519 -81980777
Website : www.hsbsk.com
E-mail : 2860864119@qq.com 1760666308@qq.com

特别声明：本样册数据由江苏悍狮霸智能科技有限公司负责解释，如有参数变更，恕不另行通知。
本样册参数仅供参考，对参数有较高要求的客户，不详之处请向我公司垂询！