



This Manual is the programming and operating manual of GSK980TB3i series bus-based tool machine CNC system.



In this Manual, we will specify all matters related to this series system as much as possible. We do not describe all unnecessary or impossible operating of this system in detail due to page limit and specific product use. Therefore, those without special instructions in this Manual should be regarded as “impossible” or “unallowable” operating.



Copyright of this Manual is owned by GSK CNC Equipment. Co., Ltd. Any organization or individual’s publishing or copying this Manual is the illegal behavior, and GSK CNC Equipment. Co., Ltd. will reserve rights to investigate the legal liabilities.

Preface

Dear customers,

Thanks for your purchasing GSK980TB3i series bus-based tool machine CNC system of GSK CNC Equipment. Co., Ltd.!

This Manual is the programming and operating manual of GSK980TB3i series bus-based tool machine CNC system (software version: V1.5) (hereinafter referred to as “this System”) and introduces programming and operating methods of this System in detail.

In order to ensure product safety and normal and effective operation, please read through this Manual prior to installation and use.

Safety Warning



Anyone without corresponding qualification is not allowed to operate this System, as accident may happen due to improper operating.

Special Note: System power supply installed on/in case is special power supply we manufacture for CNC system only.

User is prohibited to use the power supply for other purpose; otherwise, there will be great danger!

Statement!

- This Manual specifies different items as much as possible, but all operating items cannot be covered due to too many possible items involved. Therefore, those without special instructions in this Manual should be regarded as “unallowable” operating.

Warning!

- Please read this Manual and operation instruction of tool machine manufacturer carefully prior to installation, connection, programming and operating for the product. Relevant operating should follow this Manual and operation instruction strictly; otherwise, product and tool machine damage, workpiece scrapping and personal injury may happen.

Attention!

- Product function and technical index (e.g. accuracy and speed) described in this Manual are only oriented to the product. For CNC tool machine designed with the product, actual functional configuration and technical performance should be determined according to design of tool machine manufacturer and functional configuration and technical index of tool machine should be subject to operation instruction of tool machine manufacturer.

Content of this Manual will be changed without prior notice!

Safety Precautions

■Transportation and Storage

1. Six layers at most for product packing box piling up.
2. No climbing, standing or placing heavy object on product packing box.
3. No dragging or handling product with cable connected with the product.
4. Don't crash or scratch panel and display screen.
5. Product packing should not be damp or exposed to sun or rain.

■Unpacking Check

6. Confirm if it is the product you purchase after unpacking.
7. Check if the product is damaged during transportation.
8. Check if various parts are intact according to list.
9. In case of product model nonconforming, accessory shortage or damage during transportation, please contact us timely.

■Wiring

10. Those involved in wiring and check must be professionals with corresponding capacity.
11. The product must be reliably grounded, with earthing persistence not more than 0.1 Ω . Earthing line cannot be replaced with neutral line (null line).
12. Wiring must be right and stable, for fear of product damage or unexpected consequence.
13. Surge absorption diode connected with the product must be connected as per stated direction; if not, the product will be damaged.
14. Cut off power supply of the product before plugging in/out or opening product case.

■Overhaul

15. Cut off power supply prior to component overhaul or replacement.
16. In case of short circuit or overload, check the fault; the product cannot be started again until troubleshooting.
17. Too frequent power-off/on is not allowed; the product should be started again in 1 min at least if it is required to power on it after powering off.

Safety Responsibility

Safety Responsibility of Manufacturer

—Manufacturer has responsibility for danger deleted and /or controlled in design and structure of provided CNC system and accessories attached.

—Manufacturer is responsible for safety of provided CNC system and accessories attached.

—Manufacturer is responsible for using information and suggestions provided to user.

Safety Responsibility of User

—User should learn and receive training for safe operating of CNC system and be familiar with and master safe operating.

—User is responsible for safety and danger generated due to personal increasing, changing or modifying original CNC system.

—User is responsible for danger resulted from operating, adjusting, maintaining, installing and storing the product not in accordance with provisions in this Manual.

This Manual should be kept by final user.

**Thanks for your using product of GSK CNC Equipment. Co., Ltd. and
friendly support to us!**

Contents

PART I PROGRAMMING INTRODUCTION.....	1
Chapter 1 Overview.....	3
1.1 Product Introduction.....	3
1.2 Technical Specifications.....	4
1.3 Model Definition.....	6
Chapter 2 Basic Knowledge of Programming.....	7
2.1 Control Axis.....	7
2.2 Axis Name.....	7
2.3 Axis Display.....	8
2.4 Machine zero and Coordinate System.....	8
2.5 Workpiece Coordinate System.....	9
2.6 Absolute Value Programming and Increment Value Programming.....	9
2.7 Diameter and Radius Type Programming.....	10
2.8 Modal, Amodal and Initial State.....	11
Chapter 3 Part Program Composition.....	14
3.1 Program Composition.....	14
3.1.1 Program name.....	14
3.1.2 Sequence number and program segment.....	15
3.1.3 Code word.....	15
3.2 Program Structure.....	17
3.2.1 Subprogram Writing.....	19
3.2.2 Subprogram invocation.....	19
3.2.3 Program End.....	20
Chapter 4 Preparation Function G Code.....	22
4.1 Types of Preparation Function G code.....	22
4.2 Simple G Codes.....	24
4.2.1 Rapid positioning G00.....	24
4.2.2 Linear interpolation G01.....	25
4.2.3 Arc interpolation G02/G03.....	27
4.2.4 Pause (G04).....	31
4.2.6 Workpiece coordinate system selection G54-G59.....	32
4.2.7 Coordinate setting G50.....	35
4.2.8 Plane selection G17/G18/G19.....	37
4.2.9 Skip function (G31).....	38
4.2.10 Inch/ metric conversion G20/G21.....	39
4.2.11 Chamfer /corner arc with any angle.....	41
4.2.11.1 Drawing dimension direct input function.....	42
4.2.12 Equal pitch thread cutting (G32).....	44
4.2.13 Variable pitch thread cutting (G34).....	48
4.2.14 Tapping circulation code (G84 and G88).....	49
4.2.14.1 Rigid tapping (M29).....	50
4.2.14.2 Ordinary (flexible) tapping.....	55
4.2.15 Drilling circulation code.....	57
4.2.16 Ellipse instruction code.....	57
4.2.17 Parabola instruction code.....	58
4.2.18 Polar coordinate interpolation.....	60
4.2.19 Cylinder interpolation.....	63
4.2.20 Polygon cutting.....	67

4.3 Reference Point G Code.....	71
4.3.1 Automatic return to machine zero (G28).....	71
4.4 Single Fixed Circulation Code.....	72
4.4.1 Axial cutting circulation (G90).....	73
4.4.2 (G94) Radial cutting circulation (G94).....	75
4.4.3 Thered cutting circulaltion (G92).....	77
4.4.4 Precautions for Single Fixed Circulation Code.....	80
4.5 Compound Fixed Circulation Code.....	81
4.5.1 Axial rough turning circulation (Type I of G71).....	81
4.5.2 Groove circulation processing (Type II of G71).....	84
4.5.3 Radial rough turning circulation (Type I of G72).....	86
4.5.4 Groove circulation processing (Type II of G72).....	89
4.5.5 Closed cutting circulation (G73).....	91
4.5.6 Fine processing circulation (G70).....	93
4.5.7 Axial grooving circulation (G74).....	94
4.5.8 Radial grooving circulation (G75).....	96
4.5.9 Multiple thread cycles (G76).....	97
4.5.10 Notice for compound and fixed loop code.....	100
4.6 Tool Compensation Function.....	101
4.6.1 Basic concept for tool compensation function C.....	101
4.6.1.1 Concept of assumed tool nose.....	101
4.6.1.2 Direction of assumed tool nose.....	103
4.6.1.3 Setting of compensation value.....	106
4.6.1.4 Relative position of tool and workpiece.....	107
4.6.1.5 Inner and outer side.....	108
4.6.1.6 Code format of G41, G42 and G40.....	109
4.6.2 Details of tool compensation.....	109
4.6.2.1 Decomposition to detailed path of tool nose radius compensation.....	109
4.6.2.2 Change tool compensation direction in tool compensation implementation.....	117
4.6.2.3 Temporary cancellation of tool compensation.....	119
4.6.2.4 Non movement instruction contained in tool compensation.....	119
4.6.2.5 Check of tool compensation interference.....	120
4.6.2.6 Tool nose radius compensation in Code G90/G94.....	122
4.6.2.7 Tool nose radius compensation in Code G70.....	123
4.6.3 Notice for tool compensation C.....	123
4.6.4 Example of tool compensation processing C.....	123
4.7 Code G of Macro Function.....	126
4.7.1 User's macroprogram.....	126
4.7.2 Macro variables.....	127
4.7.3 Non-modal call of G65.....	135
4.7.4 Function A of user's macroprogram.....	135
4.7.5 Function B of user's macroprogram.....	139
Chapter 5 Code M of Auxiliary Function.....	145
5.1 Code M Controlled by PLC.....	146
5.1.1 Code instruction (M03, M04) for positive/reverse rotation of spindle.....	146
5.1.2 Spindle rotation stop instruction (M05).....	146
5.1.3 Cooling activation/deactivation (M08, M09).....	146
5.1.4 Chuck control (M12, M13).....	146
5.1.5 Switch of spindle speed and position mode (M14, M15).....	146
5.1.6 Spindle orientation and cancellation (M18, M19).....	146
5.1.7 Loosen and fasten Spindle C (M20, M21).....	147
5.1.8 Gear control of spindle (M41, M42, M43 and M44).....	147
5.1.9 Lubricating oil control (M32, M33).....	147
5.2 Program control Code M.....	147
5.2.1 Program end and return (M30, M02).....	147
5.2.2 Program pause (M00).....	147

5.2.3 Program selection pause (M01).....	147
5.2.4 Call of subprogram code instruction (M98).....	147
5.2.5 Return from subprogram (M99).....	148
Chapter 6 S Code of Spindle Function.....	149
6.1 Analog Control of Spindle.....	149
6.2 Switching Value Control of Spindle.....	149
6.3 Constant Surface Cutting Speed Control G96/G97.....	149
Chapter 7 F Code of Feed Function.....	153
7.1 Fast Motion.....	153
7.2 Cutting Speed.....	153
7.2.1 Feed per Minute (G98).....	153
7.2.2 Feed per revolution (G99).....	154
7.3 Linear Speed Control of Cutting.....	154
7.4 Feed Speed Magnification Keys.....	154
7.5 Automatic Speed Controlling.....	156
7.6 Speed Controlling at the Corner of Block.....	157
Chapter 8 Tool Functions.....	158
8.1 Meaning of T Code Format.....	158
8.2 Tool Offset.....	158
8.3 Programming Examples.....	159
PART II OPERATING INSTRUCTIONS.....	161
Chapter 1 Operation Panel.....	162
1.1 Panel Division.....	162
1.2 Description of Panel Functions.....	163
1.2.1 LCD (liquid crystal display) area.....	163
1.2.2 Editing keyboard area.....	163
1.2.3 Introduction to screen keys.....	164
1.2.4 Machine control area.....	165
Chapter 2 System Power-On, Shutdown, and Safe Operation.....	170
2.1 System Power-On.....	170
2.2 Shutdown.....	170
2.3 Safe Operations.....	171
2.3.1 Reset.....	171
2.3.2 Emergency stop.....	171
2.3.3 Feed hold.....	172
2.4 Circulation Start-up and Feed Hold.....	172
2.5 Over-travel Protection.....	172
2.5.1 Hardware over-travel protection.....	172
2.5.2 Software over-travel protection.....	172
2.5.3 Release of over-travel alarm.....	173
Chapter 3 Modification & Setting of Interface Display and Data.....	174
3.1 Position Display.....	174
3.1.1 Four modes of display on position page.....	174
3.1.2 Display of processing time, number of parts, programming speed, magnification, actual velocity.....	176
3.1.3 Relative coordinate clearing and halving.....	177
3.1.4 Bus monitoring page display.....	178
3.2 Program Display.....	179
3.3 System Display.....	181
3.3.1 CNC setting page.....	181
3.3.1.1 Setting and modification of password and permission.....	183
3.3.1.2 System setting and modification of date and time.....	183

3.3.2 Parameter display, modification, and setting.....	183
3.3.2.1 Parameter display.....	183
3.3.2.2 Modification and setting of parameter value.....	185
3.3.3 Display, modification, and setting of pitch compensation.....	186
3.3.3.1 Display of pitch compensation.....	186
3.3.3.2 Modification and setting of pitch compensation.....	186
3.3.4 Data backup, recovery, and transmission.....	187
3.3.5 Display, modification, and setting of bus servo parameters.....	189
3.3.5.1 Display of servo parameters.....	190
3.3.5.1.1 Modification and setting of servo parameters.....	190
3.3.5.1.2 Servo parameter setting matching motor model.....	191
3.3.5.1.3 Backup of servo parameters.....	192
3.3.5.1.4 Recovery of servo parameters.....	192
3.3.5.1.5 Servo level clearing.....	192
3.3.5.2 Servo debugging.....	193
3.3.5.2.1 Interface composition.....	193
3.3.5.2.2 Functions.....	194
3.3.5.2.3 Operating instructions.....	194
3.3.6 Timed shutdown display.....	198
3.3.6.1 Setting of timed shutdown.....	198
3.4 Offset Display.....	198
3.4.1 Display, modification, and setting of bias.....	198
3.4.1.1 Setting of bias.....	199
3.4.1.2 Modification of bias value.....	200
3.4.2 Workpiece coordinate setting page.....	200
3.4.2.1 Direct input (number).....	201
3.4.2.2 Two methods for coordinate input.....	201
3.4.2.3 Modification of workpiece coordinate system.....	202
3.4.2.4 Clearing of workpiece coordinate system.....	202
3.4.3 Display, modification, and setting of macro-variables.....	203
3.4.3.1 Display of macro-variables.....	203
3.4.3.2 Modification and setting of macro-variables.....	203
3.5 Graphic Display.....	204
3.6 Diagnosis Display.....	205
3.6.1 Diagnosis data display.....	206
3.6.1.1 Display of signal parameters.....	206
3.6.1.2 Display of system parameters.....	208
3.6.1.3 Display of bus parameters.....	208
3.6.1.4 Display of DSP parameters.....	209
3.6.1.5 Display of waveform parameters.....	209
3.6.2 Viewing of signal state.....	210
3.7 Alarm Display.....	210
3.8 Ladder Graph Display.....	212
3.9 Help Display.....	214
Chapter 4 Manual Operation.....	221
4.1 Motion of Coordinate Axis.....	221
4.1.1 Manual feed.....	221
4.1.2 Manual fast motion.....	221
4.1.3 Speed selection for manual feed and manual fast motion.....	221
4.1.4 Manual intervention.....	221
4.2 Spindle Control.....	223
4.2.1 Counter-clockwise rotation of spindle.....	223
4.2.2 Clockwise rotation of spindle.....	223
4.2.3 Spindle stop.....	223
4.2.4 Automatic gear shifting of spindle.....	223
4.3 Other Manual Operations.....	224
4.3.1 Coolant control.....	224
4.3.2 Lubrication control.....	224

4.3.3 Chuck control.....	224
4.3.4 Tailstock control.....	224
4.3.5 Manual tool changing control.....	224
4.4 Tool Setting Operation.....	224
4.4.1 Fixed-point tool setting.....	225
4.4.2 Tool setting through trial cutting.....	226
4.4.3 Tool setting of machine zero return.....	227
4.5 Adjustment of Compensation Values.....	230
Chapter 5 Single-Step Operations.....	231
5.1 Single-Step Feed.....	231
5.1.1 Amounts of movement selection.....	231
5.1.2 Selection of shifting axis and movement direction.....	231
5.1.3 Specification for single-step feed.....	231
5.2 Auxiliary Control during Single-Step Operations.....	232
Chapter 6 Manual Pulse Operations.....	233
6.1 Manual Pulse Feed.....	233
6.1.1 Selection of shifting axis and movement direction.....	233
6.1.2 Specification for manual pulse feed.....	234
6.2 Control during Manual Pulse Interruption.....	234
6.2.1 Manual pulse interruption.....	234
6.2.2 Relationship of manual pulse interruption with other functions.....	235
6.2.3 Cancellation of manual pulse interruption.....	236
6.3 Auxiliary Control during Manual Pulse Operations.....	236
6.4 Manual Pulse Trial Cutting.....	236
Chapter 7 Automatic Operations.....	238
7.1 Selection of Automatic Running Program.....	238
7.2 Initiation of Automatic Running.....	238
7.3 Stop of Automatic Running.....	238
7.4 Automatic Running from Any Block.....	239
7.5 Dry Running.....	240
7.6 Single-Block Running.....	240
7.7 Locked Running of Machine.....	242
7.8 Locked Running of Miscellaneous Functions.....	242
7.9 Adjustment of Feed and Fast Motion Speeds in Automatic Running.....	242
7.10 Adjustment of Spindle Speed in Automatic Running.....	243
7.11 Back-End Editing in Automatic Running.....	243
Chapter 8 MDI Operations.....	244
8.1 Input of Code Segment in MDI.....	244
8.2 Running and Stop of Code Segment in MDI.....	244
8.3 Modification and Clearing of Code Segment Field Value in MDI.....	244
8.4 Switching of Running Modes.....	245
Chapter 9 Zero Return.....	246
9.1 Machine Zero (Mechanical Zero).....	246
9.2 Zero Return of Program.....	246
9.2.1 Procedure for program zero return.....	246
9.3 Zero Return Setting of Bus Servo.....	246
9.3.1 Common zero return.....	246
9.3.2 Absolute zero setting and zero return.....	247
Chapter 10 Editing Operations.....	248
10.1 Program Editing.....	248
10.1.1 Program establishing.....	248
10.1.1.1 Automatic generation of sequence number.....	248
10.1.1.2 Program content input.....	249

10.1.1.3 Retrieving of sequence number, word, and line number.....	250
10.1.1.4 Cursor positioning method.....	251
10.1.1.5 Insertion, deletion, and modification of words.....	252
10.1.1.6 Deletion of one block.....	252
10.1.1.7 Modification of blocks.....	252
10.1.1.8 Deletion of code words.....	253
10.1.2 Deletion of one program.....	253
10.1.3 Deletion of all programs.....	254
10.1.4 Copying of program.....	254
10.1.5 Copying and pasting of blocks.....	255
10.1.6 Cutting and pasting of blocks.....	255
10.1.7 Replacement of blocks.....	255
10.1.8 Renaming of program.....	255
10.2 Program Management.....	256
10.2.1 Retrieval of program target.....	256
10.2.2 Number of programs stored.....	256
10.2.3 storage capacity.....	256
10.2.4 Viewing the program list.....	256
10.2.5 Program locking.....	257
Chapter 11 System Communication.....	258
11.1 GSKComm Introduction.....	258
11.1.1 Function Introduction.....	258
11.1.2 Editing operation.....	259
11.1.3 File sending (PC—CNC).....	259
11.1.4 File receiving (CNC—PC).....	260
11.1.5 Software and serial port settings.....	261
11.2 Serial Communication.....	261
11.2.1 Preparation for serial communication.....	261
11.2.2 Serial data transmission.....	262
11.3 USB Communication.....	265
11.3.1 Overview and attentions.....	265
11.3.2 Operation procedures of USB Part Program.....	265
11.3.3 Exiting from U disk operation interface.....	268
APPENDIXES.....	269
Appendix I List of GSK980TB3i Series Parameters.....	270
Parameter description.....	270
1. Position Parameters.....	271
2. Data Parameters.....	291
Appendix II Alarm Table.....	323

Part I Programming Introduction

Chapter 1 Overview

1.1 Product Introduction

GSK980TB3i series bus-based machine tool CNC system (hereinafter referred to as “the product”), as the system product newly developed and manufactured, is designed with GSK-Link industrial Ethernet bus, manual pulse trial cutting, CS axis control and other functions and has processing speed, accuracy and surface roughness improved dramatically. The brand-new human-computer interface is attractive, friendly and easy to use. With more convenient connection and more concise programming, the product can meet application requirement of universal CNC machine tool.



- Standard configured with GE series bus-based servo unit, it supports bus I/O.
- It is designed with 8.4” TrueColor LCD and supports both Chinese and English.
- The maximum control accuracy is 0.1um and the highest movement speed is 60m/min.
- Adapted with servo main axis, it has main axis orientation, CS axis control and other functions.
- Functions for single/multi metric/inch, taper and end face threads
- Manual pulse trial cutting and manual pulse interruption functions
- Support RS232 communication
- Provide time limit shutdown setting (12 issues)
- Support servo turret, four-work location electric tool carrier and hydraulic tool carrier.

1.2 Technical Specifications

Movement Control Function	Control axis: X-axis, Z-axis, Y-axis and C-axis; C-axis can serve as Cs axis.
	Interpolation mode: Positioning (G00), linear (G01) and arc (G02 and G03)
	Position instruction scope: Metric system: -999,999.99 mm-999,999.99mm; min. instruction unit: 0.0001 mm Inch system: -9,999.9999 inch-9,999.9999 inch; min. instruction unit: 0.00001 inch Note: X-axis should be shrunk by a half upon diameter programming.
	Highest feed speed: 15,000 mm/min, straight line Feed magnification: 0-200%, 21-level real-time regulation
	Highest rapid traverse: 60,000 mm/min Rapid traverse magnification: F0, 25%, 50% and 100%, four-level regulation
	Feed per revolution: 0.01 mm/r-500 mm/r (required to install 1024P/r or 1,200P/r main axis encoder)
	Acceleration/deceleration mode: Front acceleration/deceleration (linear and S types); rear acceleration/deceleration (linear and index type)
	Electronic gear proportion: Frequency doubling: 1-65,535; frequency division: 1-65,535
	Manual pulse feed: 0.001, 0.01 and 0.1 mm (three types); single-step feed: 0.001, 0.01, 0.1 and 1 mm (four types)
Interface Display	The system is designed with color 8.4" LCD display with resolution for 800×600. * Processing path display
G Function	*The system is designed with systematical A instruction format; there are 39 kinds of G codes totally, including fixed circulation code and compound circulation code. *Support statement-type macro program (macro B) *Support five-level subprogram invocation and user macro program invocation
Thread Function	* Ordinary thread (along with main axis) * Single/multi metric/inch straight thread, taper and end face threads; equal pitch thread and variable pitch threads * Length, angle and speed characteristics for thread vanishing can be set by program and parameter. * Thread pitch: 0.001 mm~500 mm (metric system) 0.06- thread/inch-25,400 threads/inch (inch system)
Compensation Function	* Pitch error compensation: Compensation interval and origin point can be set; there is single-direction or bidirectional thread compensation for choice. * Reverse clearance compensation: Fixed frequency or acceleration/deceleration compensation can be set; support G0 and G1 are designed with different reverse clearance compensations. * Tool compensation: 99 groups of tool length compensations and tool tip radius compensation
T Tool Function	* Adaptive tool carrier: Max. setting tool carrier is 16-work station tool carrier; Liuxin tool carrier (12 work stations) and Damon tool carrier (encoding or counting type) * Tool change mode: MDI/automatic absolute tool change or manual relative tool change; tool selection for positive rotation and locking for reverse rotation and mechanical zero point * Tool setting mode: Fixed-point tool setting, trial cutting tool setting and mechanical zero point return tool setting * Tool position signal input mode: Direct input
S Main Axis Function	* S2 bits (I/O gear position control)/ S5 bits (analog output) * Main axis encoder: Line number of encoder can be set (100-5,000 p/r) * Transmission ratio of encoder and main axis: (1-255): (1-255) * Main axis magnification: 50%~120% eight-level real-time regulation * Two-way 0V~10V analog voltage output; support dual- main axis control

M Auxiliary Function	<ul style="list-style-type: none"> * Designated with the address M and two-digit number; M function can be customized * M instruction in system (redefinition is not allowed): Program end: M02 and M30; program stop: M00; option stop: M01; subprogram invocation: M98; subprogram end: M99 * Cooling liquid start/stop * lubrication start/stop * MDI/automatic control chuck clamping/loosening; control tailstock entrance/exit
Programming	<ul style="list-style-type: none"> * Program capacity: 57MB, 400 programs * Format: Relative/absolute hybrid programming * Subprogram: Editable; support five subprograms nesting * Program review * background editing
Operating Function	<ul style="list-style-type: none"> * Mode selection: Edit, automatic, MDI, back to zero, manual, single step, manual pulse * Operation control: Single block, skip, dry run, auxiliary lock, program restart, manual pulse interruption, single step interruption, manual intervention, machine tool lock, interlock, feed hold, circulation startup, emergency stop, external reset signal, external power ON/OFF
PLC Function	<ul style="list-style-type: none"> * PLC processing speed: 1us/step; 8,000 steps at most; 10 basic instructions; 35 functional instructions; * I/O unit input/output: 32/32, scalable * 1~4 PMC-axis (axes) can be selected
Safety Function	<ul style="list-style-type: none"> ● Emergency stop ● Hardware stroke limit ● Data backup and recovery
Communication	<ul style="list-style-type: none"> ● RS232: Bidirectional transmission for component program, parameter and other files; support PLC program. ● USB: U disc file operating and U disc file direct processing; support PLC program and system software U disc upgrading
Adapter	<ul style="list-style-type: none"> * Switch power supply: RS-PB2 (supporting; having been installed and connected) * Drive unit: GSK GE series (including increment type and absolute type) * Tool carrier controller: GSK TB tool carrier controller

1.3 Model Definition

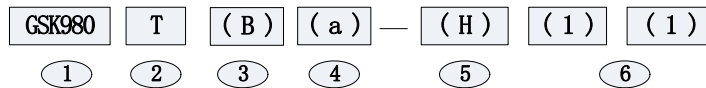

S/N	Code Description	
①	Main attribute part of product model:GSK980TB3i series	
②	Functional (processing object) configuration: Signify with capital English letters T-machine tool	
③	Series continuation: Signify with capital letters. “None” means it is initial version.	
④	Subseries continuation (or improvement No.): Signify with small English letters a, b, c..... or signified with number. “None” means it is initial version.	
⑤	Structural type or special machine type	Structural type: Respectively signified with capital letters U, H, V and B. U-United, H- horizontal, V-vertical and B-box type. Special machine type: Signified with capital letter P.
⑥	LCD size (structure) or special machine code LCD	LCD size: Signified with one-digit Arabic Numbers 1-9. 1 means 8.4”, 2 means 10.4”, 3-6 means... Special machine code: Signified with two-digit Arabic Numbers 01~99.

For example,

◆ GSK980TB3i-U1 means 980TB3i series, united structure, 8.4” LCD.

GSK980TB3i-P01: means 980TB3i series, No. 01 special machine.

Chapter 2 Basic Knowledge of Programming

2.1 Control Axis

Item	GSK980TB3i
Number of Basic Control Axes	3 axis (X, Z and C), three axes at most (including Cs-axis)

2.2 Axis Name

Default names for three basic axes are X, Z and C.

Set number of control axes with the data parameter P005; set name of each additional axis with P175-P179, e.g. axis names A, B and C.

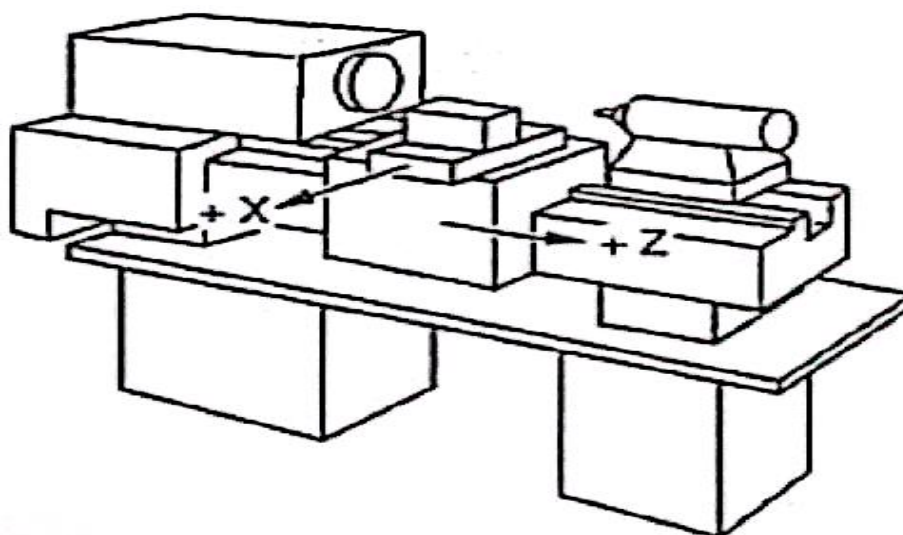

Fig. 2-2-1 Axis Diagram of Machine tool

When the system is relied on rectangular coordinate system composed of X-axis and Z-axis for positioning and interpolation movement, X-axis is front-rear direction of horizontal plane and Z-axis is left-right direction of horizontal plane. Direction approaching workpiece is negative direction and direction going away from workpiece is positive direction, as shown in Fig. 2-2-1.

The system supports front/rear tool carrier function and there is the provision: From the view of front face of machine tool, tool carrier will be called as front tool carrier if in the front of workpiece and it will be called as rear tool carrier if behind workpiece. Fig. 2-2-2 is coordinate system of front tool carrier and Fig. 2-2-3 is coordinate system of rear tool carrier. It thus can be seen from Fig. 2-2-2 and Fig. 2-2-3 that X-axis directions in coordinate systems if front and rear tool carriers are adverse, but Z-axis directions are the same. The following diagrams and examples in this Manual are about rear tool carrier; as for coordinate system of front tool carrier, you can get by analogy.

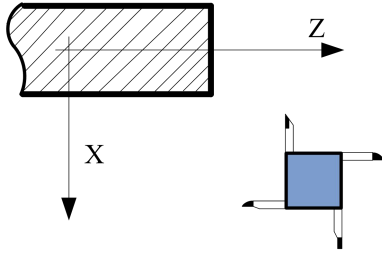

Fig. 2-2-2 Coordinate System of Front Tool Carrier

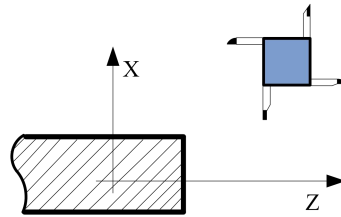

Fig. 2-2-3 Coordinate System of Rear Tool Carrier

2.3 Axis Display

For GSK980TB3i, user can set axes as linear or rotary axis through position parameter No.8#0~No.8#4; set display or hide of axes through position parameter No.58#0-No.58#4. After setting additional axis as rotary axis, unit of rotary axis will be displayed into deg. If additional axis is set as linear axis, the display will be the same with those of the basic three axes (X, Z and Y), with unit for mm. The following is axis display when X-axis and Z-axis are linear axes and C-axis is rotary axis.

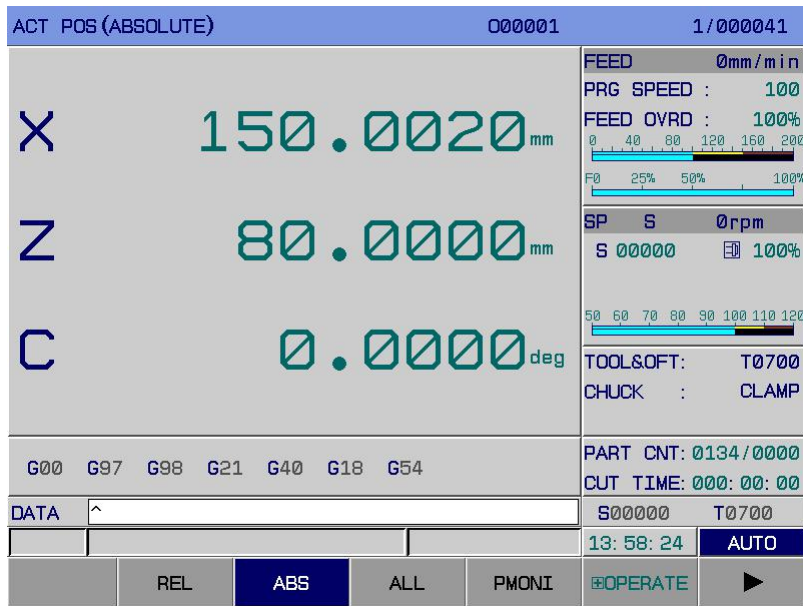

Fig. 2-3-1

2.4 Machine zero and Coordinate System

The specific point on machine tool used as processing datum is called as machine zero. Machine tool manufacturer has zero point setting for every machine tool; the zero point is usually at the part of the maximum stroke in X-axis and Z-axis directions and will not be transferred or changed after setting. Coordinate system for machine zero serving as origin point is called as machine tool coordinate system.

Since position of machine zero cannot be determined upon CNC power-on, it is generally required to return to machine zero automatically or manually, so as to establish machine tool coordinate system. CNC will be able to establish machine tool coordinate system after machine tool returns to machine zero.

Note: Do not use relevant functions of machine zero provided by the system if there is no zero return stopper on

machine tool (e.g. G28).

2.5 Workpiece Coordinate System

Coordinate system used during workpiece processing is called as workpiece coordinate system, also known as component coordinate system. Workpiece coordinate system will be preset by operator according to installation position of workpiece (workpiece coordinate system setting).

In generally, all processing procedures of one competent share a workpiece coordinate system (workpiece coordinate system selection).

Workpiece coordinate system can be changed by moving its origin point (change of workpiece coordinate system position)

Reference position point of workpiece coordinate system should meet conditions for simple programming, few size conversions and low risk for processing error. Generally, reference point is on benchmark or positioning benchmark with size mark. In terms of machine tool programming, reference point is usually at intersection of workpiece axis and chuck end face (Fig. 2-5-1) or workpiece end face (Fig. 2-5-2).

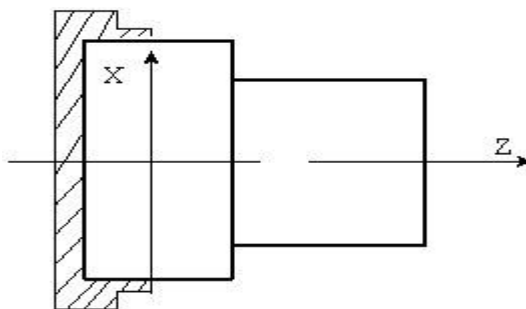

Fig. 2-5-1 Reference Point on Chuck End Face

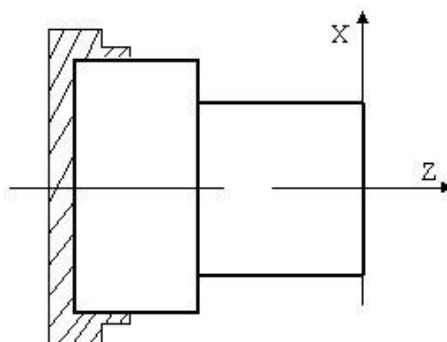

Fig. 2-5-2 Reference Point on Workpiece End Face

Workpiece coordinate system can be set with three methods below:

1. Set with G50; for details, please see 4.2.8.
2. Set with G54- G59; for details, please see II 3.4.2.1.

2.6 Absolute Value Programming and Increment Value Programming

Amount of movement for code axis can be signified with two methods: Absolute value code and relative value code. Absolute value code is programmed through coordinate value of end point position for axis movement, which is called as absolute coordinate programming. Increment value is directly programmed through axis amount of movement, which is called as increment value

programming. In the system, absolute coordinate programming is implement through directives X and Z and increment programming is implemented through directives U and W.

Table 2-6-1

Cod of Absolute Value	Code of Relative Value	Remarks
X	U	X-axis movement code
Z	W	Z-axis movement code

For example, A→B program in Fig 2-6-1 is programmed respectively through absolute value, increment value and absolute value and increment value-mixed programming modes.

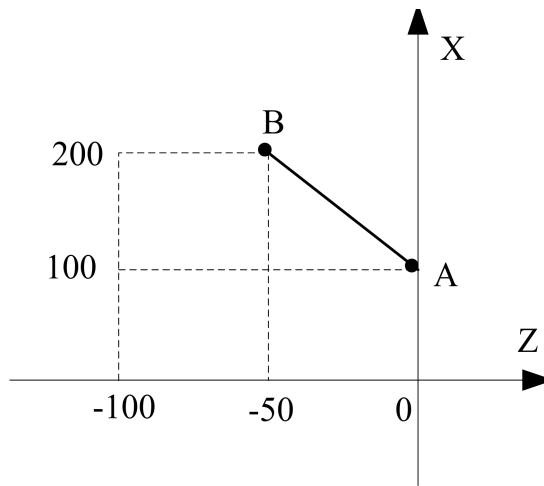

Fig. 2-6-1 Programming Method

Table 2-6-2

Programming Mode	Absolute Coordinate Programming	Relative Coordinate Programming	Mixed Coordinate Programming
Program	G1 X200 Z-50	G1 U100 W-50	G1 X200 W-50
Remakes	Suppose tool is at A point in current workpiece coordinate system, linear interpolation should be adopted for movement.		

Note: There will be alarm in case of X/Z and U/W shared segment execution in a program segment.

e.g. G50 X10 Z20;

G1 X20 W30 U20 Z30;

2. 7 Diameter and Radius Type Programming

Workpiece that CNC machine tool processes is usually rotating body; of which, X-axis size can be specified with two types: diameter and radius types, and be set through position parameter NO: 39#2.

It is diameter specifying programming when position parameter NO:39#2 is 0.

It is radius specifying programming when position parameter NO:39#2 is 1.

Table 2-7-1 Diameter and Radius Specifying Introductions

Item	Specified by Diameter	Specified by Radius
Z-axis Code	Irrelevant to diameter and radius specifying	
X-axis Code	Specified by diameter value	Specified by radius value
Increment Code of Address U	Specified by diameter value	Specified by radius value
Coordinate System Setting (G50)	Set by diameter value	Specified by radius value
X-axis Value for Tool Offset	Consistent with X-axis size; set through position parameter NO:39#2	
Radius Directive for Arc Interpolation (R, I and K)	Specified by radius value	Specified by radius value
Feed Speed in X-axis Direction	Radius variation (mm/min/mm/r)	
Position Display of X-axis	Diameter value display	Radius value display

Note: 1. The following description in this Manual is based on diameter programming, unless otherwise stated.

2. Diameter/radius application significance for tool offset refers to diameter/radius value change for workpiece outer diameter. To be specific, upon diameter specifying, diameter value for outer diameter of cutting workpiece is changed by 10 mm if compensation amount is changed by 10mm; upon radius specifying, diameter value for outer diameter of cutting workpiece is changed by 20 mm if compensation amount is changed by 10mm.

2. 8 Modal, Amodal and Initial State

Modal means that the function and state of the corresponding field, once executed, remains enabled, till the execution of its function and state is resumed. That is to say, if the same function and state are applied in subsequent program segments, it is not required to input this field.

For example,

G0 X100 Z100; (rapid positioning to X100 Z100 part)

X120 Z30; (rapid positioning to X120 Z30 part; G0, which is modal code, can be omitted and is not required to be input)

G1 X50 Z50 F300; (Linear interpolation to X120 Z30 part; feed speed: 300mm/min G0→G1)

X100; (Linear interpolation to X100 Z50 part, with feed speed for 300 mm/min; G1, Z50 and F300, which are modal codes, can be omitted and are not required to be input)

G0 X0 Z0; (rapid positioning to X0 Z0 G1→G0)

Amodal means that the function and state of the corresponding field, once executed, is enabled only once; once henceforth it is required to apply the same function and state, its execution must be resumed. That is to say, if the same function and state are applied in subsequent program segments, it is required to input this field.

Initial state means the default function and state once the system is energized. That is to say, once energized, the system executes according to the function and state in the case of initial state, provided that the corresponding function and state are not designated. The initial state of this system is G00, G18, G21, G40, G54, G97 and G98.

For example,

O0001;

G0 X100 Z100; (rapid positioning to X100 Z100 part; G0 is initial state, and the system will moves in the form of the initial state G00 in case of having no directive for other modals)

G1 X0 Z0 F100; (linear interpolation to X0 Z0 part, with system feed speed for 100 mm/min. Since G98 is minute feed mode, it is power-on initial state of the system)

Chapter 3 Part Program Composition

3.1 Program Composition

Program is composed of multiple program segments and program segment consists of characters. Various program segments are separated by program segment end code (LF for ISO and CR for EIA). In this Manual, program segment end code is signified by the character “;”.

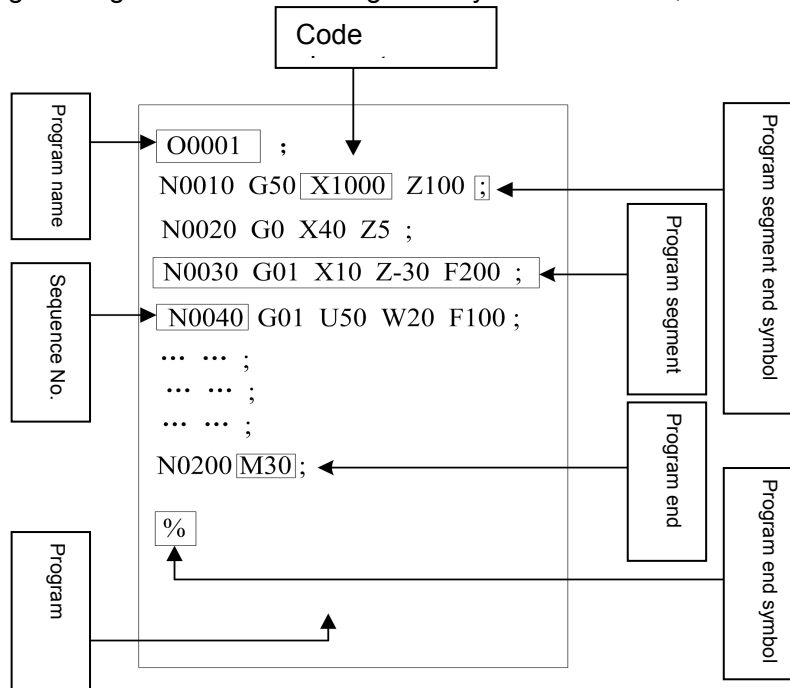

Fig. 3-1-1 Program Structure

The set of code series for CNC machine tool's part processing is called as program. After the completed program is input into CNC system, the system will control tool in moving along line or arc or make main axis rotate or stop according to codes. In program, these codes should be edited in accordance with actual movement sequence of machine tool. Program structure is shown in Fig. 3-1-1.

3.1.1 Program name

Memorizer of the system can store multiple programs. In order to distinguish these programs, program name composed of the address O and subsequent five-digit number is placed in the front of program, as show in Fig. 3-1-1-1.

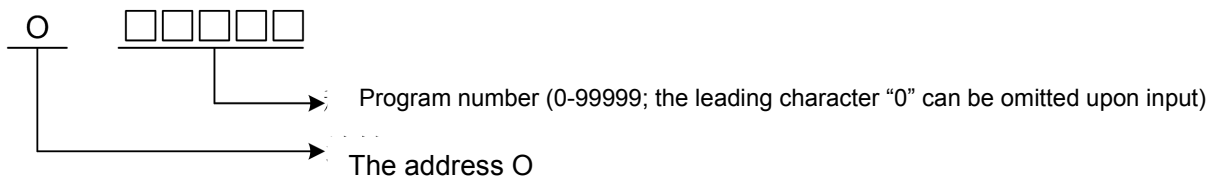

Fig. 3-1-1-1 Program Name Composition

3.1.2 Sequence number and program segment

Program is composed of multiple codes and a code unit is called as program segment, as shown in Fig. 3-1-1). Program segments are separated by program end code, as shown in Fig. 3-1-1; in this Manual, program end code is signified with the symbol “;”.

There is sequence number composed of the address N and sequent four-digit number at the beginning of program segment, as shown in Fig. 3-1-1; front leading character “0” can be omitted. Sequence number can be in random order (position parameter NO: 0 # 5 decides whether to insert sequence number automatically; for details, please see 3.3.1 in operating part); the interval can be unequal and the interval size will be set through the parameter P210. Sequence number can be arranged in all program segments or in those principal program segments; but general processing sequence should be followed and sequence number should be from the small to the big.

Note: The code N will not be treated as row number when in the same segment with G10.

3.1.3 Code word

As shown in Fig. 3-1-3-1, code word is the element for constituting program segment and composed of address and subsequent number; sometimes, there will be symbols “+” and “-” before the number.



Fig. 3-1-3-1 Code Word Composition

Address is one of English letters (A-Z) and specifies meaning of the subsequent number. Address which can be used in the system and its meaning and value scale are shown in Table 3-1-3-1:

Sometimes, one address has different meanings according to different preparation functions.

Alarm decision will be set by the parameter N0: 32#6 if there are more than two identical addresses in the same code.

Table 3-1-3-1

Address	Value Scale	Functional Meaning
A、B、C	Set by data parameters P175-179	Address in axis name
	-999,999.99-999,999.99 (mm)	A, B and C direction coordinate address
F	0.001-99,999.999 (mm/min)	Feed speed per minute
	0.001-500 (mm/r)	Feed speed per revolution
G	00-99	Preparation function
H	01-99	Operational symbol in G65
I	-99,999.999-99,999.999 (mm)	Vector of relative starting point of arc center in X-axis
	0.06-25400 (teeth/inch)	Number of inch threads
K	-99,999.999-99,999.999 (mm)	Vector of relative starting point of arc center in Z-axis
L	1-9999	Times of repeated invocation for subprogram
,L	-999,999.99-999,999.99 (mm)	Chamfer
M	Set by data parameter P204	Auxiliary function output, program execution flow and subprogram invocation
N	0-999999	Sequence number
O	0-99999	Program name
P	0-99,999.999(ms)	Pause time
	1-99,999	Subprogram invocation number
	0-999,999.99(mm)	X-axis circulation movement amount in G74 and G75
	0-99,999,999	Sequence number of starting program segment for compound circulation code fine processing
Q	0-99,999,999	Sequence number of end program segment for compound circulation code fine processing
	0-999,999.99(mm)	Z direction circulation movement amount in G74 and G75
R	-999,999.999-999,999.999(mm)	Corner value
	-999,999.999-999,999.999(mm)	Arc radius/angle displacement amount
	0-99,999.9999(mm)	Circulation retract amount of G71 and G72
	1-9,999 time (s)	Rough turning times in G73
	-9,999.9999-9,999.9999(mm)	Cutting-post retract amount in G74 and G75
	-9,999.9999-9,999.9999(mm)	Retract amount upon cutting to end point in G74 and G75
	0-99,999.999(mm)	Fine processing allowance in G76
-999,999.999-999,999.999(mm)	Taper in G90, G92 and G94	
S	Set by data parameter P205	Main axis speed designation
	00-04	Multi-grade main axis output
T	Set by data parameter P206	Tool function
U	Set by data parameters P175-179	Address in axis name
	-999,999.99-999,999.99(mm)	X-axis increment
	-999,999.99-999,999.99(mm)	X-axis fine processing allowance in codes G71, G72 and G73

Address	Value Scale	Functional Meaning
	0.0001-99,999.999 (mm)	Depth of cut in G71
	-9,999-9,999.9999(mm)	X-axis retract distance in G73
V	Set by data parameters P175-179	Address in axis name
	-999,999.99-999,999.99(mm)	Y-axis increment
W	Set by data parameters P175-179	Address in axis name
	-999,999.99-999,999.99(mm)	Z direction relative coordinate address
	0.0001-99,999.999(mm)	Depth of cut in G72
	-999,999.99-999,999.99(mm)	Z-axis fine processing allowance in G71, G72 and G73
	-9,999-9,999.9999(mm)	Z-axis retract distance in G73
X	Set by data parameters P175-179	Address in axis name
	-999,999.99-999,999.99(mm)	X direction coordinate address
	0-9,999.999(S)	Pause time designation
Y	Set by data parameters P175-179	Address in axis name
	-999,999.99-999,999.99(mm)	Y direction coordinate address
Z	Set by data parameters P175-179	Address in axis name
	-999,999.99-999,999.99(mm)	Z direction coordinate address

Table 3-1-3-1 is only for limit values for CNC device and limitation for machine tool is excluded. Please pay particular attention to it. Therefore, upon programming, it is required to consult operation instruction of tool machine manufacturer, besides referring to this Manual, and program based on understanding on program limits.

Note: 1. Length of each code does not exceed 79 characters.

2. Set Unit: Where ISC=0, the maximum and minimum are $\pm 999,999.99$ mm upon manual data input; where ISC=1, the maximum and minimum values are $\pm 99,999.999$ mm.

Set unit (metric): $\pm 999999.99\text{mm}$ $\pm 99999.999\text{mm}$

Set unit (inch): $\pm 99999.999\text{inch}$ $\pm 9999.9999\text{inch}$

Note: X-axis should be shrunk by a half upon diameter programming.

3.2 Program Structure

Program is divided into main program and subprogram. In general, CNC operates as per instructions of main program. Where there is code for subprogram invocation in main program, CNC will operate as per subprogram; when it comes to code for returning to main program in subprogram, CNC will return to the next program of the main program invoking subprogram for continuing execution. Program operation sequence is shown as Fig. 3-2-1.

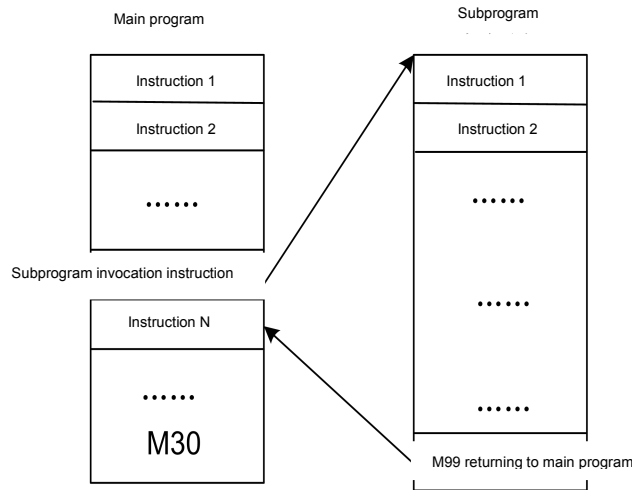

Fig. 3-2-1

Main program and subprogram are consistent in composition.

The program which has a certain fixed sequence and occurs repeatedly can be regarded as subprogram and stored in memorizer in advance, so as to avoid repeated edition and simplify program. Subprogram can be invoked under automatic mode; generally, it is invoked from main program through M98 and subprogram invoked can invoke other subprograms. Subprogram invoked from main program is called as primary subprogram; four levels of subprograms can be invoked totally, as shown in Fig. 3-2-2. The last segment of subprogram can return to main program through the code M99 to continue to invoke next segment of the program segment. Where the last segment ends with the code M02 or M30 in subprogram, the function will return to main program, just as M99, to continue to invoke next segment of subprogram.

When main program ends with M99, the program will be repeatedly executed.

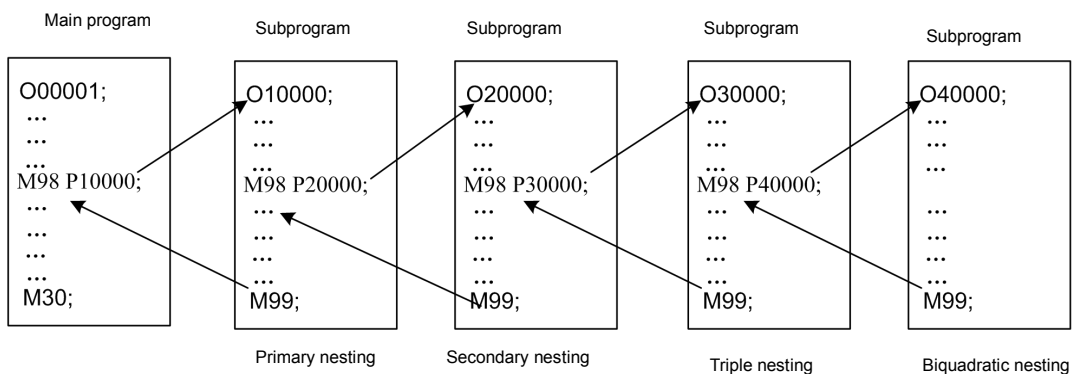

Fig. 3-2-2 Four Levels of Subprogram Nesting

One subprogram invocation code can be used to invoke the identical subprogram on a continuous and repeated basis; repeated invocation times are 9,999 at most.

3.2.1 Subprogram Writing

Subprogram writing format

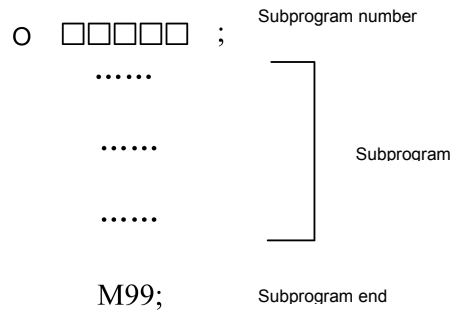

Fig. 3-2-1-1

At the beginning of subprogram, the address O is followed by subprogram number; subprogram ends with the code M99.

3.2.2 Subprogram invocation

Subprogram is invoked through main program or subprogram invocation code. Format for invoking subprogram is as follows:

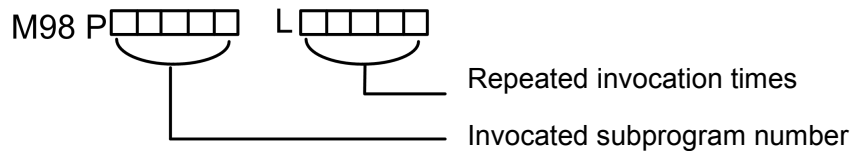

Fig. 3-2-2-1

- Repeated times should be regarded as 1 if omitted.
For example, M98 P1002L5 means subprogram with number for 1002 is invoked for 5 times in a row)
- Sequence for invoking subprogram from main program

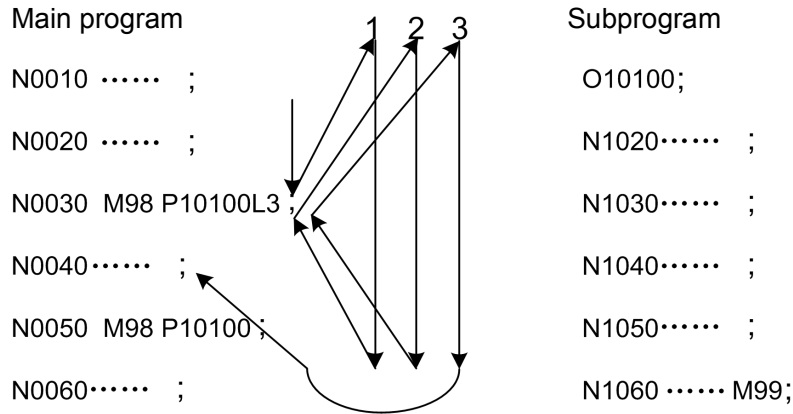

Fig. 3-2-2-2

Invoking subprogram in subprogram is the same with invoking subprogram in main program.

- Note:**
1. There will be alarm in case of failure in retrieving subprogram number specified by the address P.
 2. Subprogram with number for 90000-99999 is reserved program of the system; when user invokes this kind of subprogram, the system can execute subprogram content but cannot display the content.
 3. For subprogram invocation, there are four levels of nesting at most.

3.2.3 Program End

Program starts with program name and ends with M02, M30 or M99, as shown in Fig. 3-2-2-2. During program execution, the program under execution will end if having end code for M02 or M30, and the system will be in reset state (for M30, the position parameter N0: 33#4 can decide whether to return to program heading; for M02, the position parameter N0: 33#2 can decide whether to return to program heading). Where end code is M99, program heading will be returned to and the program will be executed on a circulatory basis. Where M99, M02 or M30 is at the end of subprogram, it is required to return to the program invoking subprogram and continue executing the subsequent program segments

Chapter 4 Preparation Function G Code

4.1 Types of Preparation Function G code

Preparation function, which is signified with G code and subsequent number, specifies meaning of program segment which it is in. G code is divided into two types below:

Table 4-1-1

Type	Meaning
Amodal G code	Only valid for program segment instructed
Modal G code	Always valid before other G codes in the same group instructed

For example, G01 and G00 are modal G codes in the same group.

G01 X __
 Z ____; G01 valid
 X ____; G01 valid
 G00 Z____; G00 valid

Table 4-1-2 Table for G code and Functions

Group	G code (System A)	Function Description	Group	G code (System A)	Function Description	
00	G04	Pause and accurate stop	02	G96	Constant surface speed control	
	G28	Returning to machine zero automatically		G97*	Constant line speed control cancellation	
	G31	Skip function	05	G98*	Feed speed per minute	
	G50	Coordinate system setting		G99	Feed speed per revolution	
	G65	Macro instruction amodal invocation	06	G20	Inch unit selection	
	G70	Fine processing circulation		G21*	Metric unit selection	
	G71	Axial rough turning circulation	07	G40*	Tool tip radius compensation cancellation	
	G72	Radial rough turning circulation		G41	Tool tip radius left compensation	
	G73	Closed ring cutting circulation		G42	Tool tip diameter compensation	
	01	G74	Axial grooving circulation	14	G54*	Workpiece Coordinate System 1
		G75	Radial grooving circulation		G55	Workpiece Coordinate System 2
G76		Multi-thread cutting circulation	G56		Workpiece Coordinate System 3	
G00*		Rapid positioning	G57		Workpiece Coordinate System 4	
G01		Linear interpolation	G58		Workpiece Coordinate System 5	
G02		Clockwise arc interpolation	G59		Workpiece Coordinate System 6	
G03		Anticlockwise arc interpolation	16		G17	XY plane selection
G32		Uniform pitch thread cutting			G18*	ZX plane selection
G34		Variable pitch thread cutting			G19	YZ plane selection
G90		Axial cutting circulation				
G92	Thread cutting circulation					
G94	Rapid cutting circulation					

- Note:**
1. Where modal and amodal codes are in the same segment, amodal code should be preferred; meanwhile, it is required to change corresponding modals according to other modal codes in the same segment but not execute them.
 2. For G code with "*" mark, the system will be in state of this G code in case of powering on. (Parts of G codes are decided by the position parameter NO: 31#0~7).
 3. G code in Group 00 is amodal code.
 4. There will be alarm in case of using G code not listed in List of G Codes or instructing G code without selection function.

5. It is allowed to instruct G codes in different groups in the same program segment; in principle, more than two codes in the same group cannot be instructed in identical program segment. It is required to be subject to subsequent G code if there is setting that there will not be alarm in case that codes in the same group are the identical segment.

6. G codes are respectively signified with their own group numbers according to different types. The position parameters NO: 35#0~7 and NO: 36#0~7 will be used to set whether to remove G codes in various groups upon reset or emergency stop.

4.2 Simple G Codes

4.2.1 Rapid positioning G00

Format: G00 X(U)_ Z(W)_

Function: Various axes move to positions designated by X (U) and Z (W) at their own rapid feed speeds.

X(U): Absolute coordinate value of X direction positioning end point (U means programming instruction of increment value and is the distance for tool movement);

Z(W): Absolute coordinate value of Z direction end point (W means programming instruction of increment value and is the distance for tool movement);

The code G00 means tool moves to the position in workpiece coordinate system designated by absolute code or increment value code at rapid feed speed. It will be set by the position parameter NO: 12#1, with tool path for any one of two types below, as shown in Fig. 4-2-1-1.

1. Linear interpolation positioning: Tool path is the same with linear interpolation (G01) and tool is positioned in the shortest time at the speed not more than rapid movement speed of each axis.
2. Non-linear interpolation positioning: Tool is positioned at the speed of rapid movement speed of each axis and tool path is not straight line.

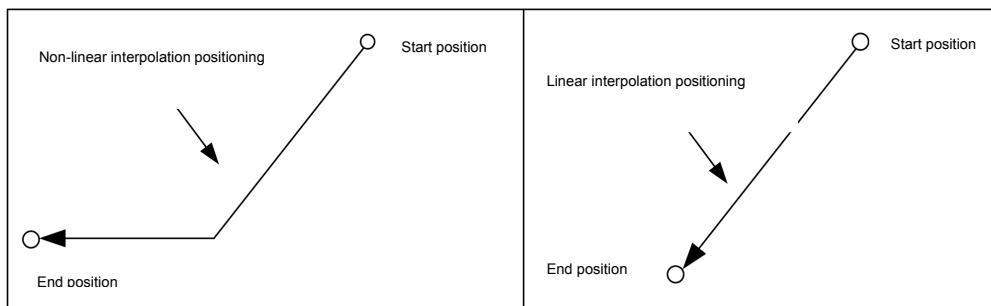

Fig. 4-2-1-1

Introductions:

1. After executing G00, the system will change modal for current tool movement mode into G00 mode. It is relied on modifying system position parameter NO: 31#0 to set system default modal upon powering on as G00 (parameter value is 0) or G01 (parameter is 1).
2. Whether positional parameter tool moves or not will not be specified; the system only change

- modal for current tool movement mode into G00.
- 3. G00 and G0 are equivalent in format.
- 4. G0 speed of X, Y, Z and C-axes is set by the parameter P88~P92.

Limits:

Rapid movement speed is set by parameter; to specific, speed of the instruction F in G0 code program is cutting feed speed for subsequent program segment.

For example,

G0 X0 Z10 F800; Feeding rapidly with speed set by system parameter

G1 X20 Z50; Feed speed of F800

Rapid positioning speed is regulated through keys on operating panel F0, 25%, 50% and 100%, as shown in Fig. 4-2-1-2. Corresponding speed of F0 is set by the parameter P93 and suitable to various axes.



Fig. 4-2-1-2 Keys of Rapid Feed Magnification

Note: Pay attention to position of workbench and workpiece, for fear of tool collision.

For example, as shown in Fig. 4-2-1-3, tool is rapidly positioned from A point to B point; relevant dimensions are shown in the figure.

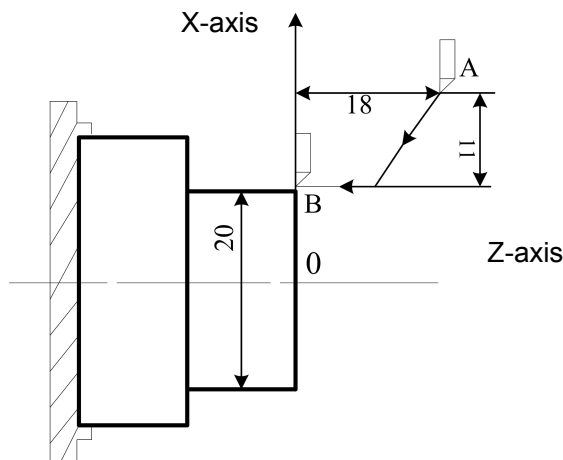

Fig. 4-2-1-3

Programming is as follows:

G0 X20 Z0; (absolute value programming, diameter programming)

G0 U-22 W-18; (increment value programming, diameter programming)

G0 U-22 Z0; (hybrid programming, diameter programming)

4.2.2 Linear interpolation G01

Format: G01 X (U)_ Z(W)_ F_

Function: Tool moves to the designated position along straight line with feed speed (mm/min) specified by the parameter F.

Introductions: X (U): Absolute coordinate value of X direction interpolation end point (U means increment value programming instruction and the distance for tool movement);

Z (W): Absolute coordinate value of Z direction interpolation end point (W means increment value programming instruction and the distance for tool movement);

1. X_ Z_ is coordinate value of end point. Since it is related to coordinate system concept, please see 2.4.
2. Feed speed specified by F is always valid until being specified by the new F value. Feed speed instructed by the code F is calculated through interpolating along linear path; where the code F has no instruction in program, feed speed will be determined according to default F value upon system powering on. For setting, please see the data parameter P87.

Code path:

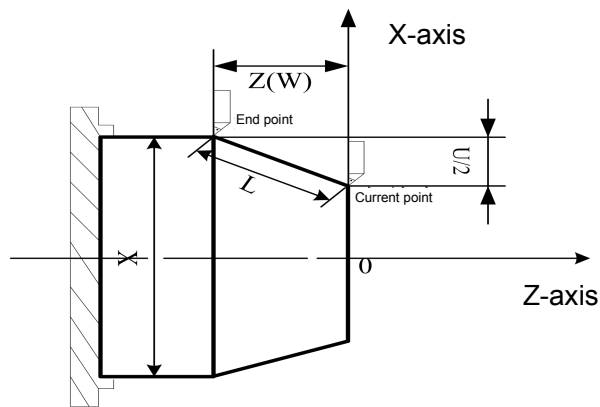
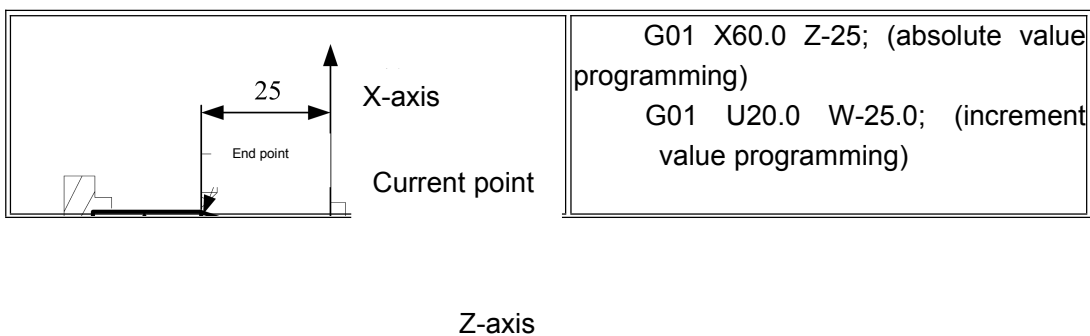

Fig. 4-2-2-1

For program example, please see Fig. 4-2-2-2.



	Note: Speed of various axes is as follows: G01 Xα ZγFf; In this program segment:
X-axis speed: $F_x = \frac{a}{L} * f$ Z-axis speed: $F_z = \frac{y}{L} * f$ $L = \sqrt{a^2 + y^2}$	

Fig. 4-2-2-2

Note:

1. All code parameters other than F are positioning parameters. The parameter P96 is used to set upper limit of cutting feed speed F. Actual cutting speed will be limited to the upper limit value if exceeding this value, with unit for mm/min. The parameter P97 is used to set lower limit of cutting feed speed F. Actual cutting speed will be limited at the lower limit value in case of exceeding this value, with unit for mm/min.
2. Tool will not move when there is no specified positional parameter behind G01, and the system only changes modal of current tool movement mode into G01. It is relied on modifying system position parameter N0: 31#0 to set system default modal upon powering on as G00 (parameter value is 0) or G01 (parameter is 1).

4.2.3 Arc interpolation G02/G03

Regulations about G02 and G03:

Arc interpolation in plane means finishing arc path moving from starting point to end point along designated rotation direction and radius (or circle center). Items below are required to be given, as arc path cannot be determined according to the known starting point and end point:

- Rotation direction of arc (G02 and G03)
- Arc interpolation plane (G17, G18 and G19)
- Circle center coordinate or radius and two code formats from that (circle center coordinate I, J and K or radius R programming)

Interpolation operation cannot be started until three items above are determined.

Arc interpolation can be implemented with codes below and tool can moves along arc, as shown below”

G17 G02 X(U)_Y(V)_ R_ F_;

G03 I_J_
Arc on XY plane

G18 G02 X(U)_Z(W)_ R_ F_;

G03 I_K_
Arc on XZ plane

G19 G02 Y(V)_Z(W)_ R_ F_;

G03 J_K_
Arc on YZ plane

Code path

Part One Programming

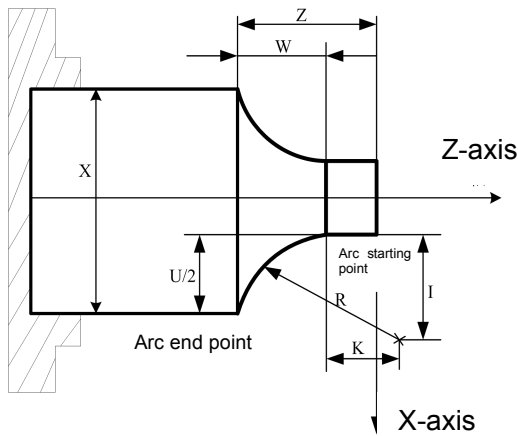

Fig. 4-2-3-1 G02 Path

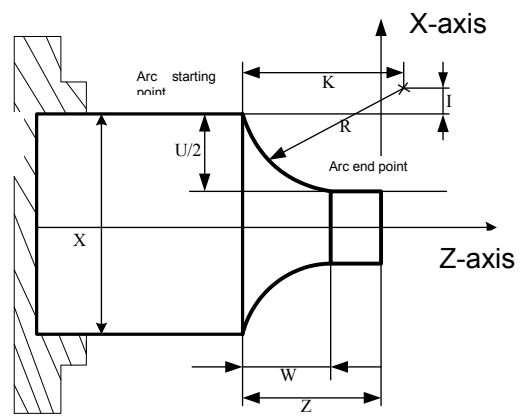

Fig. 4-2-3-2 G03 Path

X-axis

Table 4-2-3-1

Item	Content Specified	Instruction	Meaning
1	Plane specifying	G17	Specifying arc in XY plane
		G18	Specifying arc in ZV plane
		G19	Specifying arc in YZ plane
2	Rotation direction	G02	Clockwise rotation CW
		G03	Anticlockwise rotation CCW
3	End point of absolute value	Two among X-axis, Y-axis and Z-axis	Coordinate of end point in workpiece coordinate system
		Two among U-axis, V-axis and W-axis	Movement distance from starting point to end point
4	Vector from starting point to circle center	Two among I-axis, J-axis and K-axis	Coordinate of relative starting point for circle center
	Arc radius	R	Arc radius
5	Feed speed	F	Cutting speed of arc

Whether it is clockwise or anticlockwise rotation is related to coordinate system of front/rear tool carrier. In this system, coordinate system of rear tool carrier is adopted and following legends are programmed according to that. Details from position direction of Z-axis (Y-axis or X-axis) to negative direction in XY plane (ZX plane or YZ plane) are shown in Fig. 4-2-3-3.

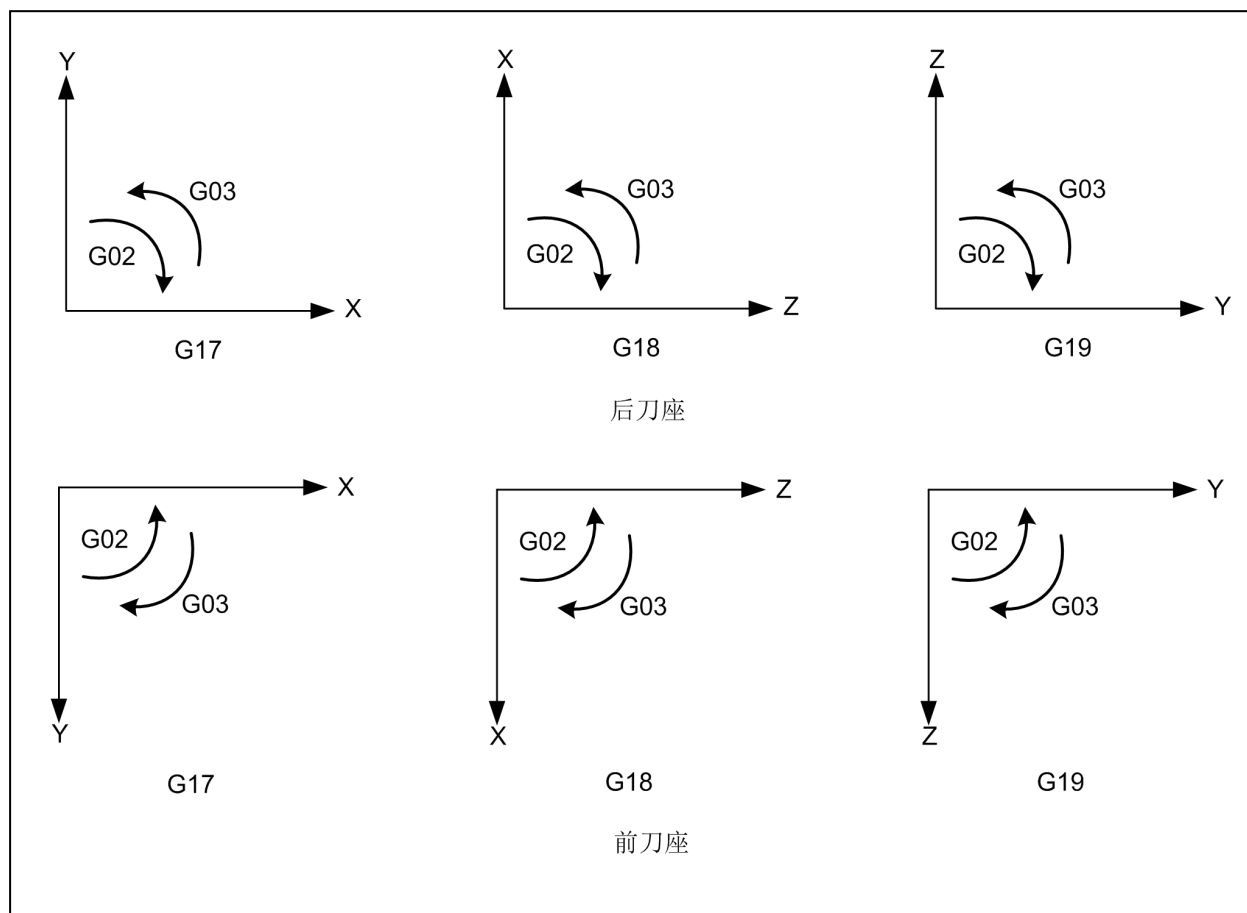

Fig. 4-2-3-3

Plane modal information defaulted upon startup can be specified by setting the position parameter NO: 31#1 and #2.

Arc end point can be specified through the parameter characters X, Y or Z. The corresponding X and Z instructions are signified with absolute value and corresponding U and W instructions are signified with increment value. Increment value is coordinate for end point being relative to starting point. Arc center is specified by parameter characters I, J and K and they respectively correspond to X, Y and Z. I, J and K parameter values are coordinates for circle center corresponding to arc starting point; simply, it is coordinate of circle center by taking starting point as coordinate origin point temporarily and is increment value with symbol. For details, please see Fig. 4-2-3-4.

Note: The system can support X-axis, Y-axis and Z-axis, but the system default is G18 plane, X-axis and Y-axis after system powering on. Instruction description is implemented according to mode the system supports and user is required to operate by combining structure of machine tool.

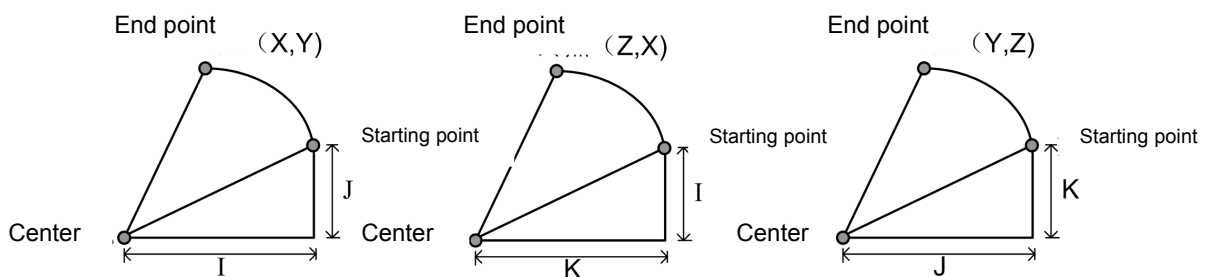

Fig. 4-2-3-4

I, J and K are attached with symbols according to direction for circle center corresponding to starting point. Besides I, J and K, arc center is specified by the radius R. The details are as follows:

G02 X_ Z_ R_;

G03 X_ Z_ R_;

1. Draw two arcs below: Circle more than 180° and circle less than 180°. For arc more than 180°, the radius is specified by negative value.

For example, as shown in Fig. 4-2-3-5, when Arc of ① is less than 180°, it will be G02 U60 W20 R50 F300; when arc of ② is more than 180°, it will be G02 U60 W20 R-50 F300.

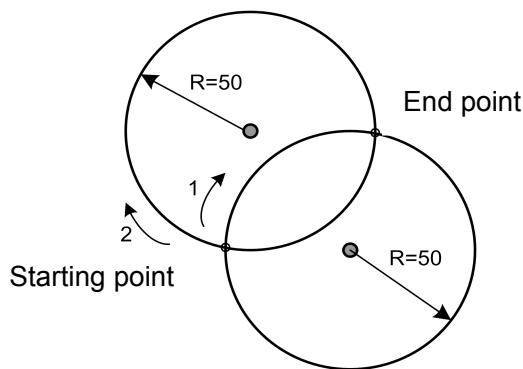

Fig. 4-2-3-5

2. Arc equal to 180° can be programmed through I, J and K and R.

For example, G0 X0 Z0; G2 X40 I10 F100;

Equal to G0 X0 Z0; G2 X40 R10 F100

or G0 X0 Z0; G2 X40 R-10 F100

Note: For 180° arc, positive/negative value of R has no influence on arc path.

3. Arc equal to 360° can be programmed only through I, J and K.

For example, program in Fig. 4-2-3-6 is written through G02 code.

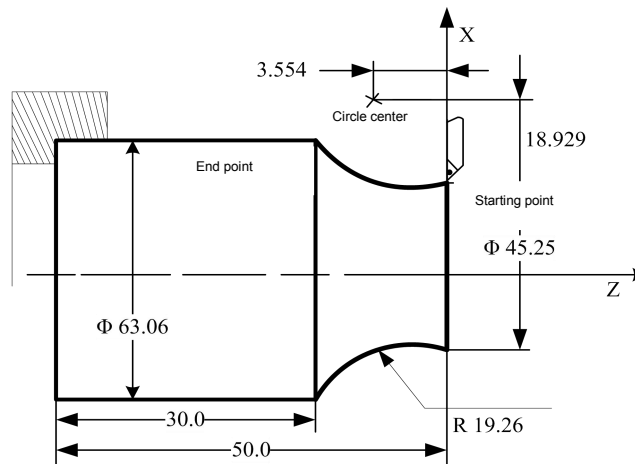

Fig. 4-2-3-6

Program (current point of tool is at starting point):

```
G02 X63.06 Z-20 R19.26 F300;
or G02 U17.81 W-20.0 R19.26 F300;
or G02 X63.06 Z-20 I18.929 K-3.554 F300
or G02 U17.81 W-20.0 I18.929 K-3.554 F300;
```

Limits:

1. If program specifies addresses I, J, K and R simultaneously, arc specified by the address R should be preferred and others should be ignored.
2. The system will give alarm if arc radius parameter and parameter from starting point to arc center.
3. Full circle interpolation should be implemented only by specifying parameters I, J and K from starting point to arc center; specifying R is unfeasible.
4. Attention should be paid to selection setting for coordinate plane upon arc interpolation.
5. Tool will not move if both X and Z are omitted, namely, positions of starting point and end point are the same, and R (G02R50) is specified.

4.2.4 Pause (G04)

Format: G04 X(U) _ or P_

Function: G04 executing pause operating means executing next program segment according to designated time delay. Specified pause per revolution for feed mode G99 per revolution can be set by the position parameter No.34#0.

Table 4-2-4-1 Instruction Value Scope of Pause Time (X or U Instruction)

Minimum Movement Unit	Scope of Instruction Value	Unit of Pause Time
No.5#1=0	0.001-9,999.999	s or rev
No.5#1=1	0.0001-9,999.999	

Table 4-2-4-2 Instruction Value Scope of Pause Time (P Instruction)

Minimum Movement Unit	Scope of Instruction Value	Unit of Pause Time
No.5#1=0	1-99999.999	0.001s or rev
No.5#1=1	1-99999.999	0.0001s or rev

Instructions:

1. G04 is amodal code and only valid in current row.
2. X (U) value is valid when X (U) and P parameters appear simultaneously.
3. There will be alarm when X (U) and P are negative values.
4. The system will not execute pause operating when both X (U) and P are not specified.

4.2.6 Workpiece coordinate system selection G54-G59

Function: Specifying current workpiece system by specifying G code of workpiece coordinate system in program and selecting workpiece coordinate system

Format: G54-G59

Instructions:

1. Parameter without code
2. The system can set six workpiece coordinate systems, and any one of these coordinate systems can be selected through codes G54-G59.

- G54 ----- Workpiece Coordinate System 1
- G55 ----- Workpiece Coordinate System 2
- G56 ----- Workpiece Coordinate System 3
- G57 ----- Workpiece Coordinate System 4
- G58 ----- Workpiece Coordinate System 5
- G59 ----- Workpiece Coordinate System 6

3. The system will display the workpiece coordinate systems G54-G59, G50 or additional workpiece coordinate system having been executed upon power failure.
4. When different workpiece coordinate systems are invoked from program segment, instruction movement axis will be positioned to coordinate point under the new workpiece coordinate system; where there is no instruction movement axis, coordinate will skip into corresponding coordinate value under the new workpiece coordinate system and actual machine position will not be changed.

For example, Corresponding machine tool coordinate for origin point of G54 coordinate system is (10, 10).

Corresponding machine tool coordinate for origin point of G55 coordinate system is (30, 30) .

Upon executing program in order, absolute coordinate of end point and machine tool coordinate will be displayed as follows:

Table 4-2-6-1

Program	Absolute Coordinate	Machine Tool Coordinate
G0 G54 X50 Z50	50, 50	60, 60
G55 X100	100, 30	130, 60
X120 Z80	120, 80	150, 110

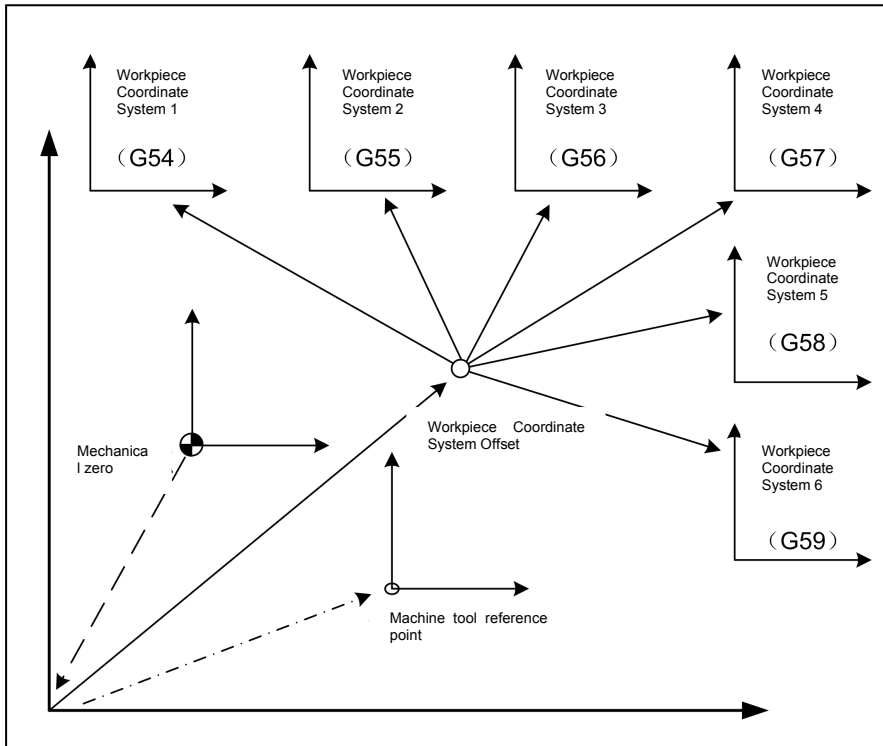

Fig. 4-2-6-1

As shown in Fig. 4-2-6-1, it is required to return to machine zero manually after machine tool startup and enable machine zero to build machine tool coordinate system, so as to generate machine reference point and determine workpiece coordinate system. Origin points of six workpiece coordinate systems can be specified by inputting coordinate offset or setting data parameters P15-P44 under type-in mode; the six coordinate systems are set by distance from machine zero to zero points of various coordinate systems.

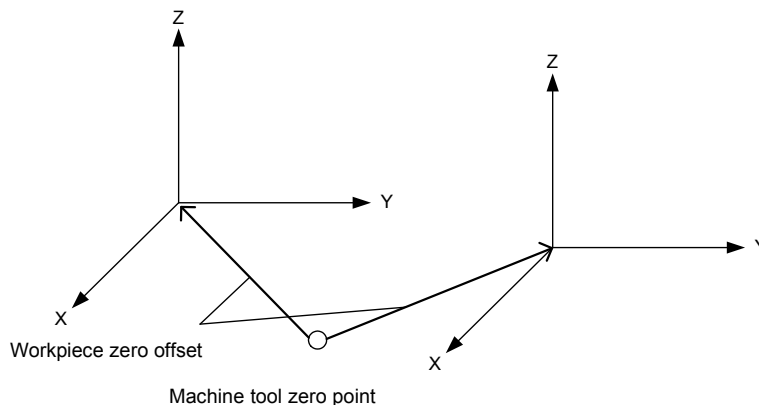

Fig. 4-2-6-2

For example, N10 G55 G00 X100 Z20;

N20 G56 X80.5 Z25.5;

In examples above, position of G55 workpiece coordinate system (X=100, Z=20) will be rapidly positioned when it is started to execute N10 program segment. Position of G56 workpiece coordinate

system will be rapidly positioned and absolute value will change into coordinate value under G56 workpiece coordinate system (X=80.5, Z=25.5) when it is started to execute N20 program segment.

4.2.7 Coordinate setting G50

1) Workpiece coordinate system setting

Format:G50 X(U) _ Z(W) _;

Function: Workpiece coordinate system setting. Two code characters are used to specify absolute coordinate value of tool tip position on current tool carrier under the new workpiece coordinate system. The code will not make movable axis move.

Instructions: X: Absolute coordinate value of X-axis for current tool tip point in workpiece coordinate system;

Z: Absolute coordinate value of Z-axis for current tool tip point in workpiece coordinate system;

1. Once coordinate system is established, all absolute value code positions in subsequent codes will signify position of this coordinate system, until the new coordinate system set by G50 code is used.
2. When parameter is set as diameter, X direction will specify diameter; when parameter is set as radius programming, X direction will specify radius.

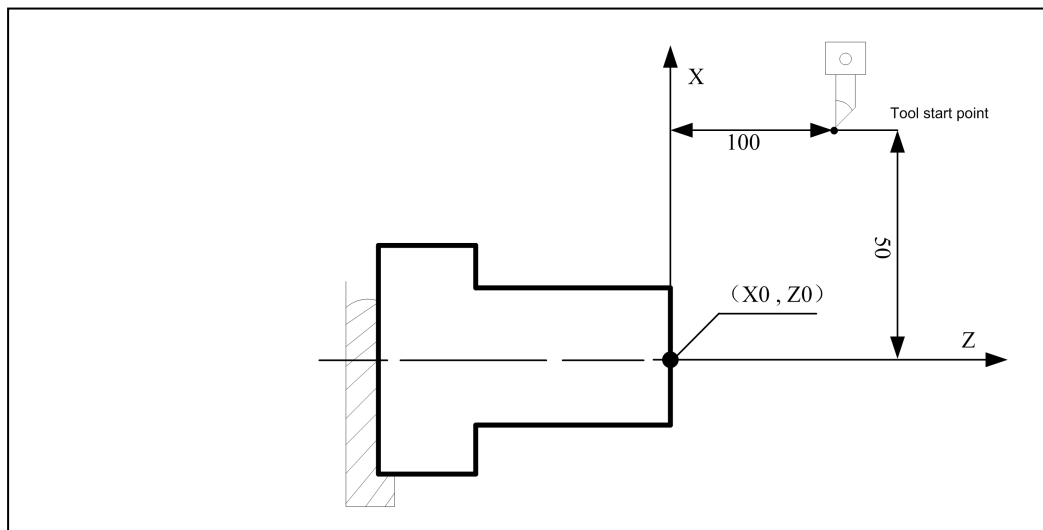

Fig. 4-2-7-1

As shown in Fig. 4-2-7-1, workpiece coordinate system in the figure is established and position of tool tip in current workpiece coordinate system is determined after executing the code G50 X100 Z100. For specific coordinate setting method, please see 4.1.5 *tool setting* in operating part.

Note: 1. G50-based coordinate system setting should be completed under the premise that tool offset has been cancelled. After setting, the absolute coordinate is setting value of G50; tool offset cancellation can be executed under MDI mode: "T0100 G00 U0 W0", suppose current tool offset state is T0101.

2. Set coordinate system through G50 under tool offset state and absolute coordinate will display circumstances below:

A. Tool offset has been executed, i.e. there is movement instruction after tool offset; the absolute coordinate after setting is setting value of G5, as shown in table below:

Table 4-2-7-1

Program (Executing Tool Compensation in the Form of Coordinate Offset)	Display Value of Absolute Coordinate	Compensation Value of No. 01 Tool
G0 X0 Z0	X:0 Z:0	X:-12 Z:-23
T0101	X:12 Z:23	
G0 X0 Z0	X: 0 Z:0	
G50 X20 Z20	X:20 Z:20	

B. Tool offset has not been executed yet, i.e. there is no movement instruction after tool offset, including tool offset cancellation and setting. After setting, absolute coordinate after setting reflects tool offset value.

The details as shown in table below:

Table 4-2-7-2

Program (Executing Tool Compensation in the Form of Coordinate Offset)	Display Value of Absolute Coordinate	Compensation Value of No. 01 Tool
G0 X0 Z0	X:0 Z:0	X:-12 Z:-23
T0101	X:12 Z:23	
G0 X50 Z50	X:50 Z:50	
T0100	X:38 Z:27	
G50 X20 Z20	X:8 Z:-3	

Table 4-2-7-3

Program (Executing Tool Compensation in the Form of Coordinate Offset)	Display Value of Absolute Coordinate	Compensation Value of No. 01 Tool
G0 X0 Z0	X:0 Z:0	X:-12 Z:-23
T0101	X:12 Z:23	
G50 X20 Z20	X:32 Z:43	

2) Horizontal movement of coordinate system

Format: G50 U_ W_;

Function: Horizontally moving tool tip on tool carrier by one distance designated by parameter in original coordinate system, i.e. corresponding relation for tool tip new coordinate to position in original coordinate system is: X+U, Z+W.

Instruction: When parameter is set as diameter programming, X direction will specify diameter; when parameter is set as radius programming, X direction will specify radius.

4.2.8 Plane selection G17/G18/G19

Format: G17/G18/G19

Function: Plane selection is required upon arc interpolation, tool radius compensation or drilling and boring. It can be implemented through G17/G18/G19.

Instructions: Where there is no instruction parameter, system default is G18 plane upon startup. System default plane after startup can also be determined by setting the position parameters N0:31#1, #2 and #3.

G17-----XY plane

G18-----ZX plane

G19-----YZ plane

Plane will not change if G17, G18 and G19 are in program segment without instruction.

For example, G18 X_ Z_; ZX plane

Note: Currently, the system only supports fixed circulation under G18 plane. Upon programming, in consideration of conforming and strictness, it had better specify plane clearly in corresponding program segment, especially for circumstance where the system is shared by several people, for fear of accident or abnormality due to programming error.

4.2.9 Skip function (G31)

Format: G31 X(U) _ Z(W) _ F_

Function: The code, which is behind the code G31, can instruct linear interpolation, just as G01.

Code execution will be interrupted and the next program will be executed in case of inputting an external skip signal during execution for this code. It is required to use skip function when processing end point is not programmed and is specified by signal from machine tool, e.g. cutting. Skip function is also used in workpiece size measurement.

Instructions:

1. G31 is amodal G code and only valid in specified program segment.
2. During tool radius compensation, alarm will be displayed in case of sending G31 code; it is required to cancel tool radius compensation before G31 code.

For example,

As shown in Fig. 4-2-9-1, next program segment of G31 is single axis movement instructed by increment value:

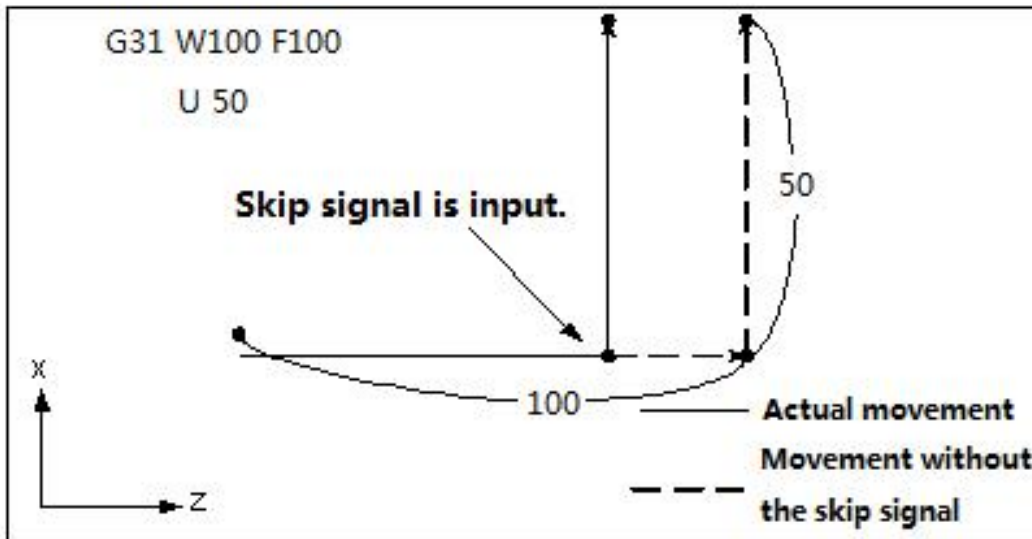

Fig. 4-2-9-1 Next Program Segment Is Single Axis Movement Instructed by Increment Value
As shown in Fig. 4-2-9-2, next program segment of G31 is single axis movement instructed by absolute value:

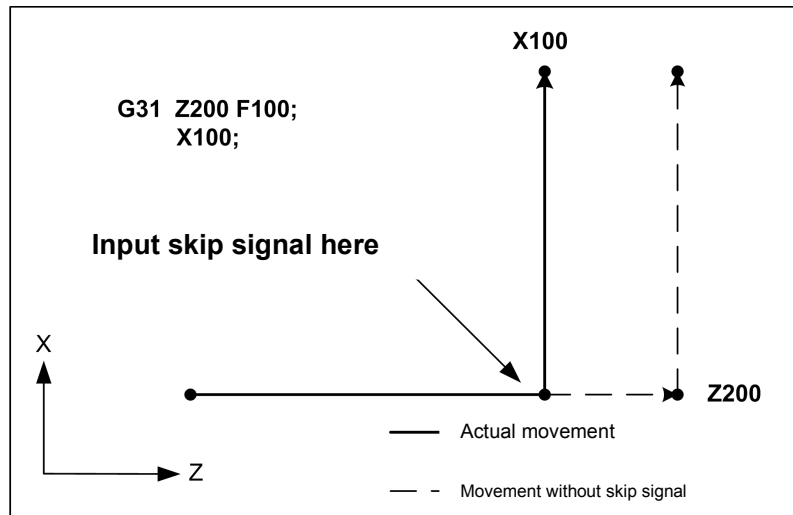

Fig. 4-2-9-2 Next Program Segment Is Single Axis Movement Instructed by Absolute Value

As shown in Fig. 4-2-9-3, next program segment of G31 is dual-axis movement instructed by absolute value:

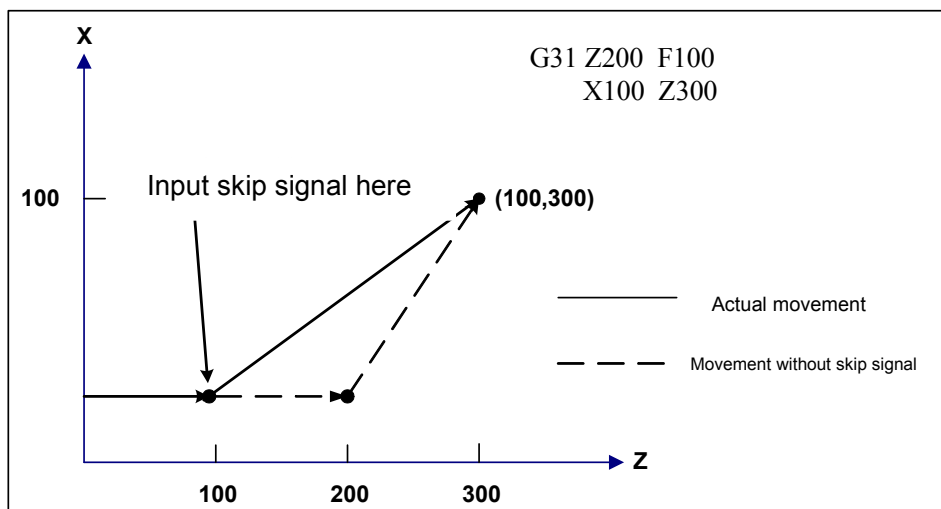

Fig. 4-2-9-3 Next Program Segment Is Dual-axis Movement Instructed by Absolute Value

Note: Setting can be implemented through the position parameter NO: 04#7 (skip signal SKIP, which will serve as signal input when 0 is 1 and 1 is 0).

4.2.10 Inch/ metric conversion G20/G21

Format: G20: Inch input

G21: Metric input

Function: Inch/metric conversion for program input

Instructions:

Change units of following values after inc/metric conversion:

Feed speed instructed by the code F, position code, workpiece zero offset, tool compensation value, scale unit of manual pulse generator and movement distance in increment feed.

State between G code and power failure is the same upon powering on.

Note: 1. Tool compensation value must be preset according to the minimum input increment unit when inch system is switched to metric system or metric system is switched to inch

system.

2. Reference points for operation of the first G28 code from middle center and manual return are the same when inch system is switched to metric system or metric system is switched to inch system.
3. The maximum error will be a half of the minimum order unit and this error will not accumulate when the minimum input increment unit and minimum order increment unit are different.
4. Program can be set to input inch/metric system through the position parameter NO:00#2.
5. Program can be set to output inch/metric system through the position parameter NO:00#1.
6. It is necessary to specify G20 or G21 in the independent program segment.
7. When inch input is used, parameters of system axes regarding distance and speed will be displayed in an inch basis and set by the position parameter NO:41#3.

4.2.11 Chamfer /corner arc with any angle

Format: L_: Chamfer

R_: Corner arc transition

Function: When the code above is at the end of linear interpolation (G01) or arc interpolation (G02 and G03) program segments, chamfer or transition arc should be automatically added out of corner during processing. Program segment for chamfer or corner arc transition can be continuously specified.

Instructions:

1. Chamfer refers to distance from virtual inflection point to starting point and end point of corner behind L; the virtual inflection point refers to the really existing corner point suppose chamfer is not executed. The details are shown in the figure below:

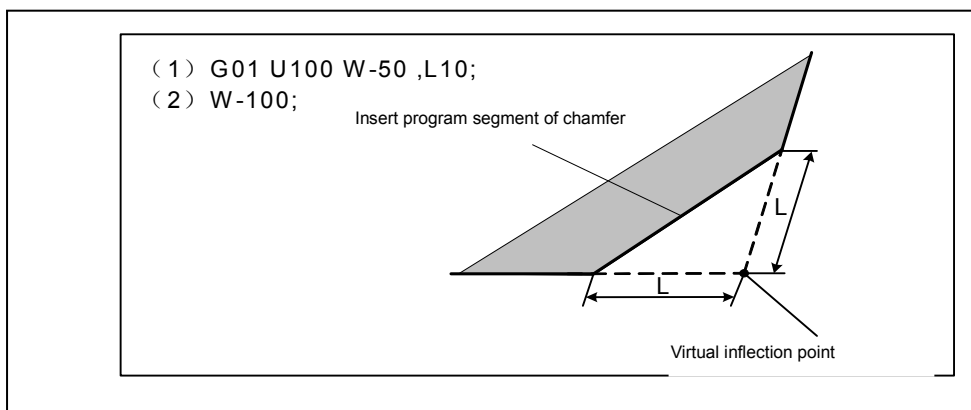

Fig. 4-2-11-1

2. As shown in figure below, corner arc radius is specified when corner arc transition is behind R:

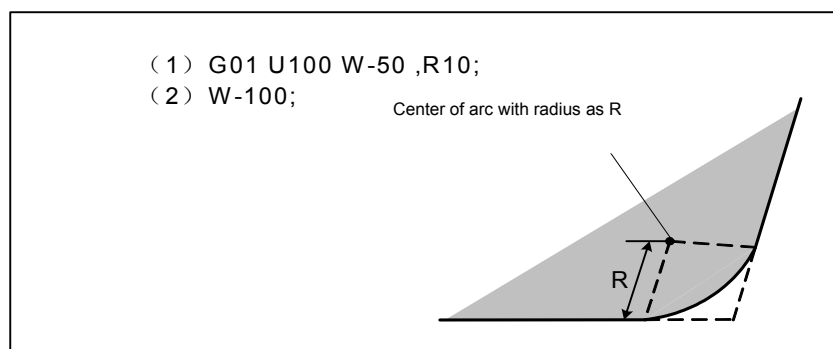

Fig. 4-2-11-2

Limitation:

1. Chamfer and corner arcs should be executed only in designated plane; parallel axis is not available for these functions.
2. There will be alarm if the inserted chamfer or arc transition program segment makes tool beyond interpolation movement scope.
3. Corner arc transition cannot be specified in thread processing program segment.
4. When values for instructing chamfer and corner are negative, the system will select

absolute value of these two values.

4.2.11.1 Drawing dimension direct input function

There are parts of straight lines marked with angle whose endpoints are not accurate in position in processing drawing. With the drawing dimension direct input function, user can directly use angle and chamfer values of straight line in processing drawing to program.

Instruction format: Drawing dimension direct input function is only used in linear interpolation (G01) and can be specified in G17 plane (YX plane), G18 plane (XZ plane) and G19 plane (ZY pane). The instruction format below is about G18 plane (XZ plane). Format change is as follows in case of using G17 and G19 planes: G17 plane: "Z"→"X" and "X"→"Y"; G19 plane : "Z"→"Y" and "X"→"Z".

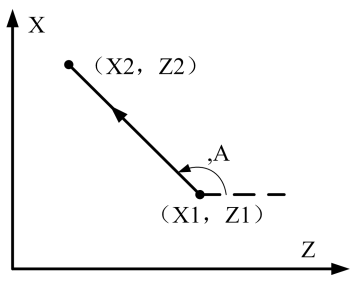
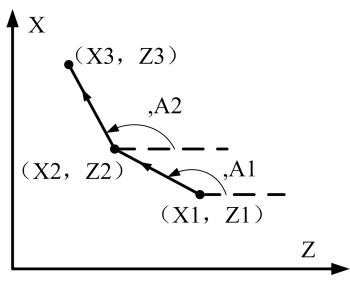
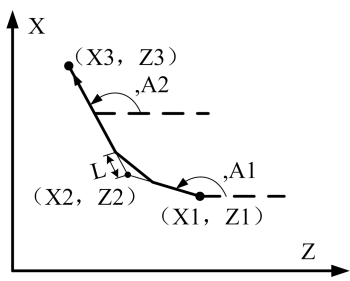
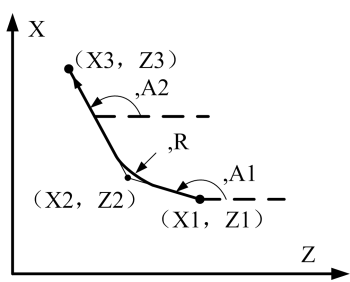
	Instruction Format	Instruction Path
1	G01 X2_ (Z2_) ,A_	
2	G01 ,A 1_ G01 X3_ Z3_ ,A 2_	
3	G01 ,A 1_ ,L 1_ G01 X3_ Z3_ ,A 2_	
4	G01 ,A 1_ ,R_ G01 X3_ Z3_ ,A 2_	

	Instruction Format	Instruction Path
5	<pre>G01 ,A 1_ ,L 1_ G01 X3_ Z3_ ,A 2_ ,L 2_ G01 X4_ Z4_</pre>	
6	<pre>G01 ,A 1_ ,R 1_ G01 X3_ Z3_ ,A 2_ ,R2_ G01 X4_ Z4_</pre>	
7	<pre>G01 ,A 1_ ,R 1_ G01 X3_ Z3_ ,A 2_ ,L2_ G01 X4_ Z4_</pre>	
8	<pre>G01 ,A 1_ ,L 1_ G01 X3_ Z3_ ,A 2_ ,R2_ G01 X4_ Z4_</pre>	

Precautions:

- Both G00 and G01 instructions can be used in drawing dimension direct input function; but G00 only has positioning effect in case of using G00 direct drawing dimension input function.
- In Instruction Format 1, angle tolerance for intersection calculation should be $\pm 1^\circ$, for fear that calculated movement distance is too long. (Q value is converted into 0° - 360°)
 - $X_Q_$ (there will be alarm if the angle Q is within $(0^\circ \text{ or } 180^\circ) \pm 1^\circ$.)
 - $Z_Q_$ (there will be alarm if the angle Q is within $(0^\circ \text{ or } 270^\circ) \pm 1^\circ$.)
- Upon intersection calculation, there will be alarm if angle difference for the two straight lines is within $\pm 1^\circ$.
- It is required to specify coordinate value (absolute instruction) and angle instruction value in movement program segment behind the program segment only specifying angle instruction.

For example, N1 X_ Q_
 N2 Q_
 N3 X_ Z_ Q_

(It is necessary to specify absolute instruction value and angle instruction Q of X-axis and Z-axis in N3

program segment; if not, there will be alarm.)

- G04 and M, S and T program segments can be inserted in continuous drawing dimension direct input instruction; but there will be alarm if there are two or more inserting program segments.

- In compound fixed circulation, drawing dimension direct input program can be used in program segments among sequence numbers specified by P or Q; but program segment specified by Q sequence number is not allowed to be in the middle of continuous drawing dimension direct input instruction.

4.2.12 Equal pitch thread cutting (G32)

Format: G32 X(U) __Z(W) __ F(I) __ J__K__Q__;

Function: Simultaneous thread cutting of two axes from starting point (position before G32 code operation) to end point specified by X(U), Z(W) and Y(V); the path is shown in Fig. 4-2-12-1. The code can realize cutting for equal pitch straight, taper and end face threads.

Introductions: X(U): Absolute coordinate value of X direction thread cutting end point (U is increment value programming instruction and the distance for tool movement);

Z(W): Absolute coordinate value of Z direction thread cutting end point (W is increment value programming instruction and the distance for tool movement);

F: Metric thread pitch, i.e. movement amount for tool corresponding to workpiece each time main axis rotates once, with value scope for 0.001 mm-500 mm; it is a modal parameter;

I: Threads per inch for inch thread, with value scope for 0.06 thread/inch-25,400 thread/inch; it is a modal parameter;

J: Movement amount in short axis direction upon thread vanishing (vanishing amount), with value scope for -99,999,999-99,999,999; x is the minimum input increment, with unit for mm/inch, designed with positive/negative direction; this value will specify radius if short axis is X-axis; J value is a modal parameter.

K: Length in long axis direction upon thread vanishing, with value scope for 0-99,999,999; x is the minimum input increment, with unit for mm/inch, without direction; this value will specify radius if long axis is X-axis; K value is a modal parameter.

Starting angle refers to offset angle of single-transfer signal of main axis and thread cutting starting point, with value scope for 0-360°. Q value is an amodal parameter and must be specified when used; if not, the system will regard starting angle as 0°.

Q using rules:

1. Default value of starting angle is 0°, if Q is not specified.
2. For continuous thread cutting, except for Q in the first segment, Q specified by subsequent thread cutting segments will be invalid; it will be ignored even though defined.
3. Unit of Q is 1°. It is required to input Q180 in program if Q has 180° offset with single-transfer signal of main axis. It can be used in multi-thread cutting. Thread starting angle should be calculated according to number of threads.

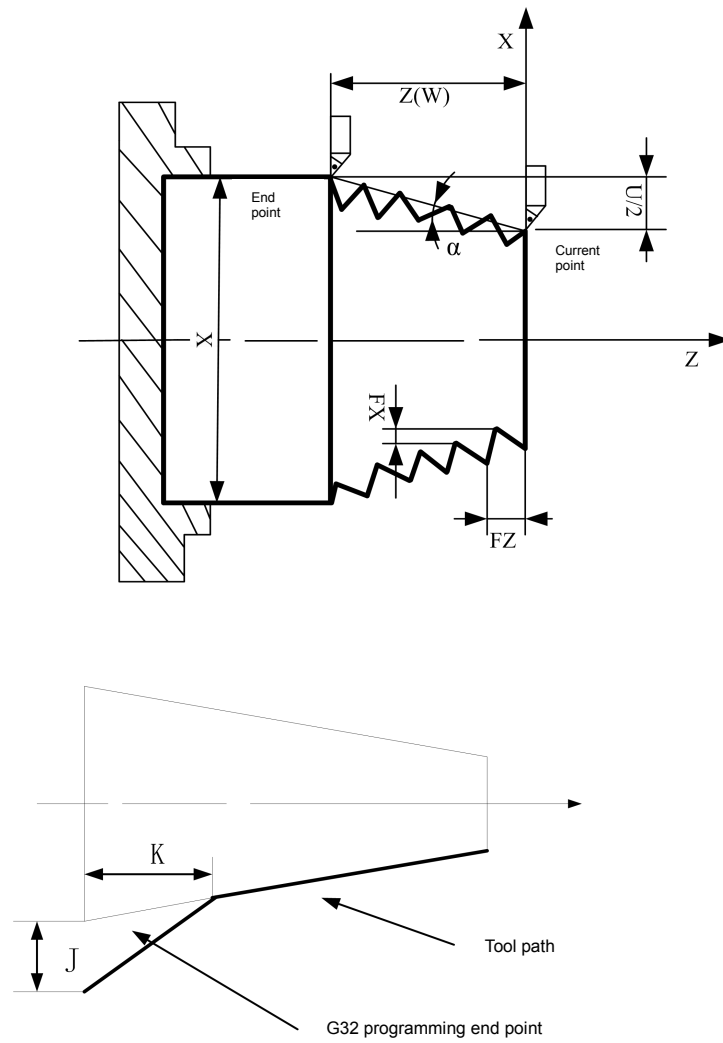

Fig. 4-2-12-1

As shown in Fig. 4-2-12-2, the system is designed with long and short axes; calculation method is as follows:

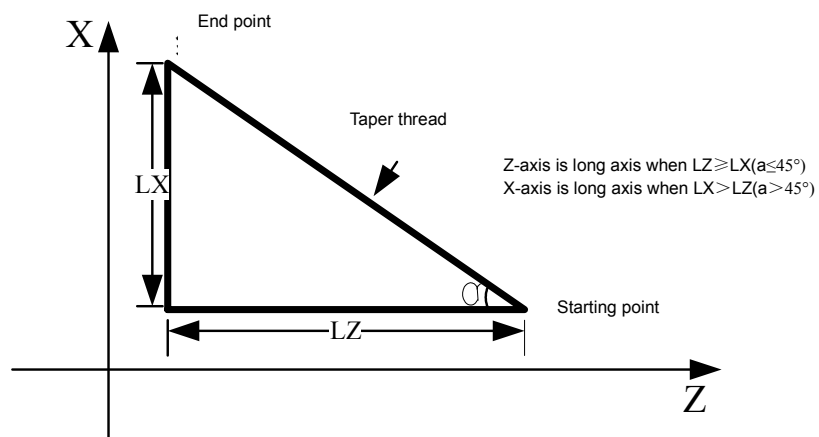

Fig. 4-2-12-2

Precautions for thread cutting:

1. In thread cutting starting and end parts, in general, there is pitch error due to acceleration/deceleration. In consideration of that, instructed thread length should be longer than required value, as shown in Fig. 4-2-12-3.
2. During thread cutting, feed speed magnification is invalid and always 100%.
3. During thread cutting, main axis magnification is invalid, because thread cannot be cut correctly due to acceleration/deceleration influence once main axis magnification is changed.
4. The system will display “feed hold” after executing feed hold operating. Thread cutting will not be stopped until current program segment is executed; where it is continuous thread processing, movement will not be stopped and program operation will not be paused until thread cutting program segment is executed.
5. During single-segment operation, movement will be stopped after executing current program segment; if it is continuous thread processing, movement will be stopped after executing thread cutting program segment.
6. The current program will also be thread cutting segment if the last program segment is thread cutting program segment; upon cutting starting, it is not required to test transfer signal of encoder in the part of main axis.
7. Main axis speed must be constant; thread will have offset to some degree in case that main axis speed is changed.
8. The system will give alarm when F and I occur in the same program segment simultaneously.
9. J and K are modal codes. Upon thread cutting, J and K are not allowed to be specified; they are required to be specified in the last segment of thread code. It is required to cancel J and K modal in case of executing non-thread cutting code.
10. There will be no vanishing when J or J and K is omitted; there will be vanishing as per $K=J$ when K is omitted.
11. There will be no vanishing when $J=0$ or $J=0$ and $K=0$.
12. There will be vanishing as per $K=J$ when $K=0$ or K is omitted.

Example 1: Write program in Fig. 4-2-12-3 with G32 code, with thread pitch for 4mm.

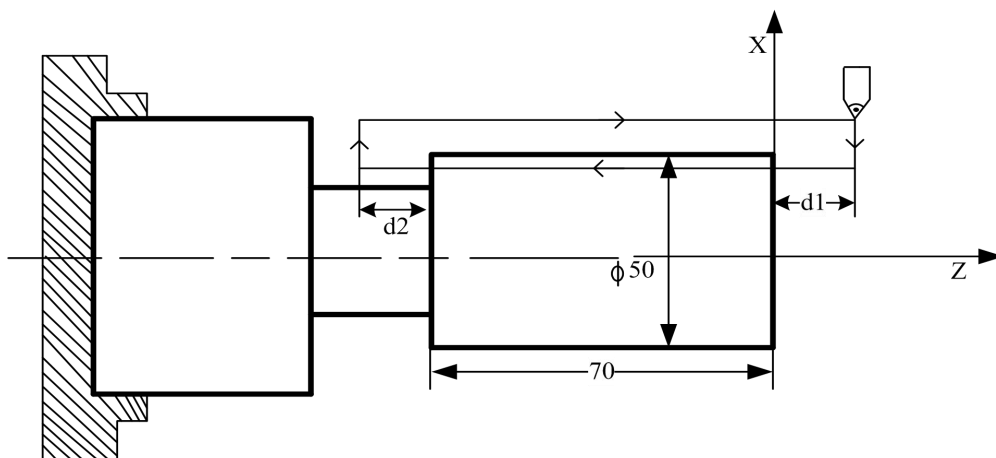

Fig. 4-2-12-3

Program: $d1 = 3\text{mm}$, $d2 = 1.5\text{mm}$, total cutting depth: 1mm (single edge), cutting by two times.

```

G0 X100 Z50; (rapid positioning)
M03 S200; (start main axis; set speed as 200)
T0101; (invoke thread chaser)
G0 X49 Z3; (rapid positioning; cut by 1mm for the first time)
G32 W-74.5 F4.0;
G00 X55;
W74.5;
X48;          (rapid positioning, cut by 1mm for the second time)
G32 W-74.5 F4.0;
G00 X55
W74.5;
G0 X100 Z50 M05;
M30;
    
```

Example 2: Write program in Fig. 4-2-12-4 with G32 code; long axis is Z-axis and thread pitch is 3mm.

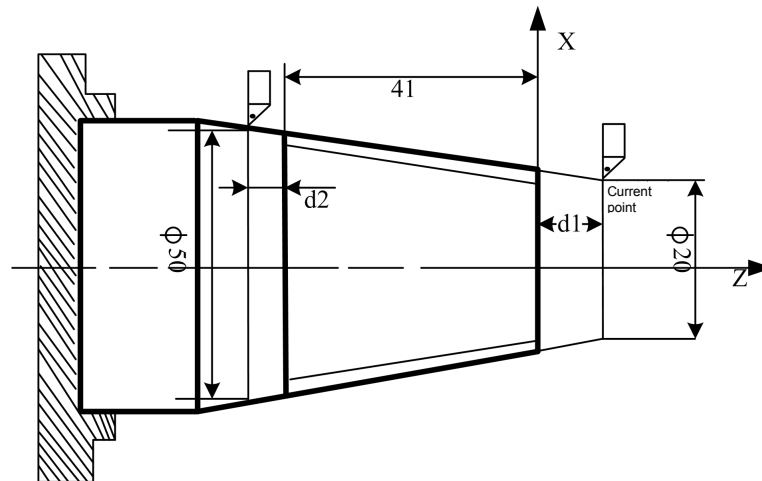

Fig. 4-2-12-4

Program: $d1 = 2\text{mm}$, $d2 = 1\text{mm}$, total cutting depth: 1mm (single edge), cutting by two times.

```

G0 X100 Z50; (rapid positioning)
M03 S200; (starting main axis; setting speed as 200)
T0101; (invoking thread chaser)
G00 X19 Z2;          (rapid positioning; cut by 1mm for the first time)
G32 X49 Z-41 F3;
G00 X55;
Z2;
G0 X18;          (rapid positioning, cut by 1mm for the second time)
G32 X48 Z-41 F3;
G0 X55;
Z2;
G0 X100 Z50 M05;
M30;
    
```

4.2.13 Variable pitch thread cutting (G34)

Format: G34 X(U) __Z(W) __ F(I) __J__ K__R__Q__;

Function: Simultaneous thread cutting of two axes from starting point (position before G32 code operation) to end point specified by X(U), Z(W) and Y(V). The code can realize cutting for variable pitch straight, taper and end face threads.

Instructions: X(U): Absolute coordinate value of X direction thread cutting end point (U is increment value programming instruction and the distance for tool movement);

Z(W): Absolute coordinate value of Z direction thread cutting end point (W is increment value programming instruction and the distance for tool movement);

F: Metric thread pitch, i.e. pitch of thread starting point with value scope for 0.001 mm-50m; it is a modal parameter;

I: Threads per inch for inch thread, i.e. pitch of thread starting point with value scope for 0.06 thread/inch-25,400 thread/inch; it is a modal parameter;

J: Movement amount in short axis direction upon thread vanishing (vanishing amount), with positive/negative direction; this value will specify radius if short axis is X-axis; J value is a modal parameter.

K: Length in long axis direction upon thread vanishing, with value scope for 0-99,999,999; x is the minimum input increment, with unit for mm/inch, without direction; this value will specify radius if long axis is X-axis; K value is a modal parameter.

R: Increment or decrement of threads per revolution on main axis. Value scope of R is $\pm 0.000001\text{mm}$ - $\pm 500\text{mm}$ and ± 0.000001 inch- ± 19.685 inch. The system will give alarm when increment or decrement of R value is beyond allowable value or pitch decreases to 0 or negative value. Meanwhile, there may be thread inaccuracy resulted from slow deceleration during thread processing.

Q: Starting angle refers to offset angle of single-transfer signal of main axis and thread cutting starting point, with value scope for 0-360°. Q value is an amodal parameter and must be specified when used; if not, the system will regard starting angle as 0°.

Q using rules:

1. Default value of starting angle is 0°, if Q is not specified.
2. For continuous thread cutting, except for Q in the first segment, Q specified by subsequent thread cutting segments will be invalid; it will be ignored even though defined.
3. It is required to input Q180 in program if Q has 180° offset with single-transfer signal of main axis. It can be used in multi-thread cutting. Thread starting angle should be calculated according to number of threads.

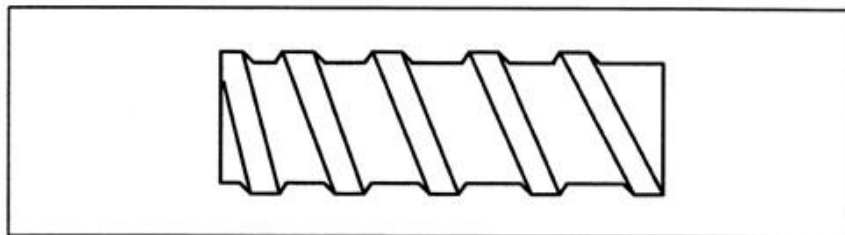

4.2.14 Tapping circulation code (G84 and G88)

980TB3i machine tool system is relied on end face tapping circulation (G84) and side face tapping circulation to realize tapping function. Tapping is divided into ordinary (flexible) tapping and rigid tapping. For ordinary (flexible) tapping mode, main axis rotation and tapping axis feed mount are independently controlled and have synchronization relationship not met well. With respect to rigid tapping mode, main axis motor has the same control mode with servo motor; main axis revolution has corresponding relation with feed amount along the direction of main axis direction and main axis acceleration/deceleration also maintains this relation. Rigid tapping main axis, in which floating clip or variable screw tap is not required (they are required in ordinary tapping mode), has more rapid and accurate tapping operating.

In terms of rigid tapping mode, machine tool must enjoy corresponding condition: Using position of main axis is controlled and used as Cs-axis; if not, the system will not support it.

With respect to ordinary tapping mode, auxiliary function should be used to control startup and shutdown of main axis: M03 (main axis positive rotation), M04 (main axis reverse rotation) and M05 (main axis stop); CNC tests main axis rotation through main axis encoder and tapping axis follows rotation of main axis. Ordinary tapping mode will be a relatively economical tapping mode when machine tool cannot use rigid tapping function.

Function of rigid tapping code: Rigid tapping circulation can be enabled when main axis motor is controlled and under rigid mode.

Function of ordinary tapping code: During movement, when main axis rotates once, Z-axis will move by one pitch and be always consistent with screw tap pitch; with one spiral notch formed in workpiece, one time of cutting is enough to realize thread processing in inner hole.

4.2.14.1 Rigid tapping (M29)

Format:

M29 S****; M29 decides rigid tapping; S** is main axis speed.
 G84 X (U)_ C (H)_ Z (W)_ R_ P_ Q_ F_ K_ M_ ; end face tapping circulation
 G88 Z (W)_ C (H)_ X (U)_ R_ P_ Q_ F_ K_ M_ ; side face tapping circulation
 G80; Fixed circulation cancellation

Instructions:

M29 Sxxxx : Rigid tapping mode; Sxxxx is main axis speed.
 X_ C_ or Z_ C_ : Hole position data, only valid in designated program segment; hole position data can also specify effective axis of non-X, Z and C axes.
 Z(W)_ or X(U)_ : Specifying coordinate value of hole bottom with absolute value or specifying distance form R plane to hole bottom with increment value, only valid in designated program segment.
 R_ : Distance from initial plane to R point; it is the radius value, with direction.
 P_ : Pause time at hole bottom, with unit for 1ms.
 Q_ : Cutting amount for each time; it is the radius value.
 F_ : Cutting feed speed
 K_ : Program executing times
 M_ : M code for C-axis clamping (if required)
 G80 : Fixed circulation cancellation

It is required to cancel fixed circulation before executing M29 instruction; if not, the system will give alarm.

M29 instruction is M code for rigid tapping and used to specify alarm specified by S or resulted from axis movement between M29 and G84/G88 program segments. There will be alarm in case of specifying M29 repeatedly, as M29 is an unrepeatable instruction.

M29 Sxxxx instructs rigid tapping mode. After receiving M29, PLC will make corresponding switching and main axis will stops rotation. Main axis output in M29 segment is equivalent to S0 output.

Main axis rotation can be firstly specified before G84/G88 instruction; operator should determine whether main axis rotates positively or reversely according to screw tap used. CNC will determine M code for reverse rotation of main axis according to rotation direction of main axis before G84/G88; in G84/G88 ordinary tapping circulation, main axis default, unless specified, is output main axis positive rotation M03 upon tapping.

Whether tapping feed axis specifies X-axis or Z-axis is relied on G84/G88. Tapping axis specified by G84 is Z-axis and tapping axis specified by G88 is X-axis. Relevant G signal will determine which main axis is used (related to PLC program of system operation).

Determine thread pitch through cutting feed speed F (i.e. feed speed of tapping axis) and main axis speed S.

Under feed per minute mode, cutting feed speed $F = \text{thread pitch formula} * \text{main axis speed } S$;

Under feed per revolution mode, cutting feed speed $F = \text{thread pitch formula}$.

Standard rigid tapping circulation (Q value is not specified or Q value is 0) is as follows:

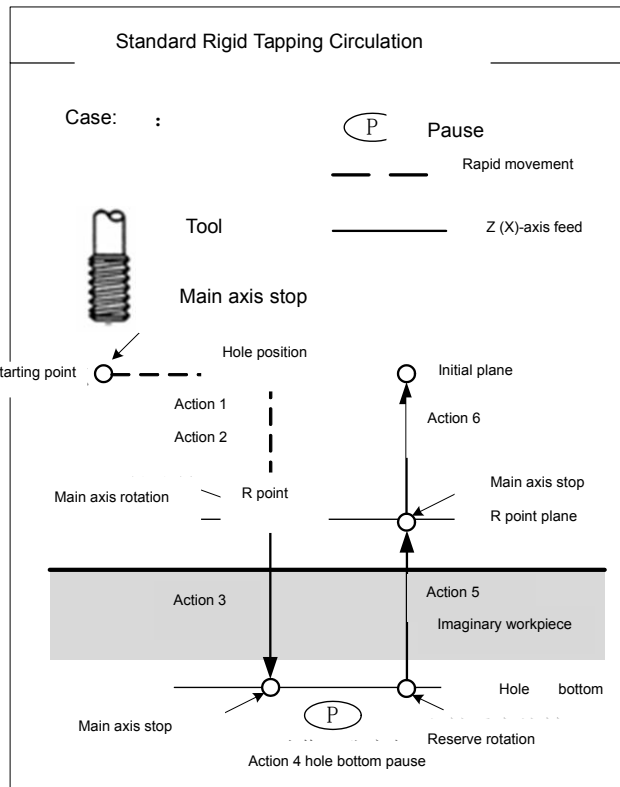

Format:

G84 X (U)_ C (H)_ Z (W)_ R_ P_ F_ K_ M_;

G88 Z (W)_ C (H)_ X (U)_ R_ P_ F_ K_ M_;

Code execution process:

1. Tool is rapidly positioned to hole position from starting point, a point determined by hole position data in initial plane;
2. Rapid positioning to R point;
3. Main axis starts rotation and tapping axis has cutting feed to hole bottom plane at the speed designed by F; when tapping axis arrives at hole bottom, main axis will stop rotation;
4. Pause the pause time designated by P;
5. Main axis starts reverse rotation and tapping axis retracts to R point plane at the speed specified by F;
6. Main axis stops rotation and returns to initial plane rapidly;
7. Standard rigid tapping circulation ends.

Repeat from Step 1 under the premise of instructing K_ repetition times.

Note: 1. R instruction, which is about distance from initial plane to R point, is always radius value and can be omitted; after omitted, initial plane is should be regarded as R plane.

2. G84/G88 can realize no-load operation; feed speed F is feed speed for system no-load operation.

3. It is required to cancel tool tip radius compensation upon tapping circulation pause; recover tool tip radius compensation upon fixed circulation cancellation.

4. S value used in rigid tapping will also be eliminated upon fixed circulation cancellation of rigid tapping, which is the same with the condition where S0 state is specified. That is to say, it is not allowed to used S specified by rigid tapping in program after cancelling fixed circulation of rigid tapping.

5. It is required to specify S again after cancelling fixed circulation of rigid tapping.

6. In tapping program segment, there will be alarm when R plane is out of initial plane and hole bottom plane.

7. Tapping cutting deceleration will stop upon system reset, emergency stop or drive alarm. In this process, main axis has the definite course for stopping rotation but Z-axis has stopped feed, so workpiece and screw tap may have scrap risk. Therefore, during processing, do not interrupt G84/G88 compulsorily as

much as possible.

8. In case of single-pass operation or feed execution and operating maintaining, the system will display "pause" and tapping circulation will not stop until it returns to starting point after finishing tapping.

9. Upon tapping cutting, movement speed of tapping axis will be decided by main axis speed and thread pitch; it is not related to cutting feed speed magnification.

Example 1: Rigid tapping of Main Axis 1 is used in center hole end face.

For example,

Thread M10×2 in the figure

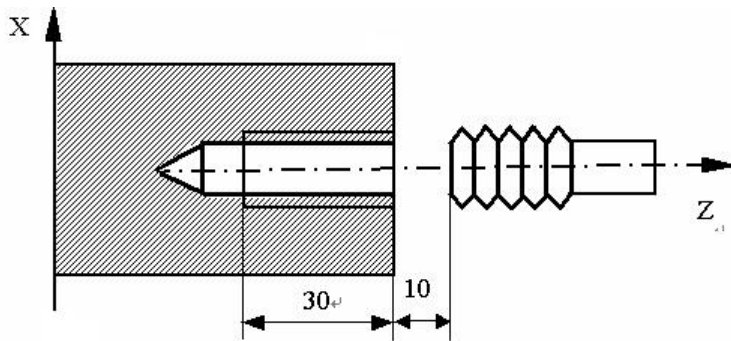

<p>G98; G0 X0 Z10; M29 S500; G84Z-30R-4P1000F1000;</p>	<p>Feed per minute mode Position X-axis and Z-axis to starting point. Specify rigid tapping, with main axis speed for 500 RPM G84 is end face rigid tapping circulation; starting point is X0 Z10, R plane position is Z6, hole bottom position is Z-30 and hole bottom pause time is 1 s; through F value and S value instructed, thread pitch is 2.</p>
<p>G80; M30;</p>	<p>Fixed circulation cancellation Program ends</p>
<p>G99; G0 X0 Z10; M29 S500; G84Z-30R-4P1000F2;</p>	<p>Feed per revolution mode Position X-axis and Z-axis to starting point Specify rigid tapping, with main axis speed for 500 RPM G84 is end face rigid tapping circulation; starting point is X0 Z10, R plane position is Z6, hole bottom position is Z-30 and hole bottom pause time is 1 s; through F value and S value instructed, thread pitch is 2.</p>
<p>G80; M30;</p>	<p>Fixed circulation cancellation Program ends</p>

Example 2: Main Axis 2 is applied in non-center hold end face and side end tapping.

Parameter setting:

Position parameter

NO.0#4=1 Use dual-main axis control or not(0: No 1: Yes)

NO.1#6=1 Speed output selection of Main Axis 2 (0: analog voltage 1: pulse train position)

NO.36#2=1 Eliminate G code in Group 10 or not upon reset or emergency stop (0: No 1: Yes)

Number parameter

NO.424 0 Servo axis number upon position output of speed instruction pulse training for Main Axis 2 (0: Invalid 1-5: Axis 1-5)

Set corresponding axis according to actual tapping axis; NO.424 is required to be set as 4, if B axis of Axis 4 serves as tapping axis.

PLC K parameter:

K7.0=1 Use main axis contour control or not (0: No 1: Yes)

K7.4=1 Switch detection switch or not in main axis position (0: No 1: Yes)

K7.7=1 Use main axis position mode or not (0: No 1: Yes)

PLC T parameter:

T11 4000 Switching time for main axis position mode (M code is completion time if there is no detection switch)

PMC-axis parameter setting:

For example, B axis of Axis 4 serves as PMC-axis or tapping axis control

Gear ratio setting

Minimum movement unit of the system: 0.0001

Gear ratio= $131072/3600000=2048/56250$

1. Set gear ratio to system side:

System parameter NO.163=2048

System parameter NO.168=56250

2. Set gear ratio respectively to system side and drive side:

System parameter NO.168=10

GE2000 drive unit PA12=2048

GE2000 drive unit PA13=5625

Note: It is required to set gear ratio 2048/56250 to drive side separately; speed controlled by PMC-axis should not exceed 500 revolutions (too large for pulse number for system sending); it is suggested to set gear ratio of PMC-axis to system side.

System position parameter:

NO.38#1 is set as 0 In multi-axis control, main axis selection through process instruction P code or not (0: No 1: Yes)

NO.60#2 is set as 1 PMC-axis selection is specified by G signal or not (0: No 1: Yes)

System parameter:

NO.422 M63 M code for positive rotation of Main Axis 2

NO.423 M64 M code for reverse rotation of Main Axis 2

NO.540 0 System axis number controlled by PMC-axis (0: None 1-5: Axis 1-5)

NO.541 0.0010 Minimum unit of data controlled by PMC-axis (0.0001-360.0)

NO.542 500 Acceleration/deceleration time in speed instruction controlled by PMC-axis

Note: It is not required to set NO.540 when system position parameter NO.60#2=1 (PMC-axis selection is specified by G signal). NO.540 is required to set corresponding PMC-axis when system position parameter NO.60#2=0 (PMC-axis selection is not specified by G signal).

PLC D data table:

D0251 Attribute selection of Main Axis 2 (0: analog 1: Axis 1 2: Axis 2 3: Axis 3...)

Set corresponding axis according to actual tapping axis; D251 is required to be set as 4, if B axis of Axis 4 serves as tapping axis.

Example about PMC-axis control:

B axis serves as PMC-axis control

M63 S600 600 RPM for B axis positive rotation

M64 S800 600 RPM for B axis reverse rotation

M65 B axis stops

M code control for main axis clamping/release:

K008.0 =1 Use main locking device (0: No 1: Yes)

M20 Main axis locking output

M21 Main axis release output

Y002.6 Main axis locking output

Y006.7 Main axis servo excitation lowering signal

Example 1: Tap 6 threads on outer circle with diameter for 100 through Main Axis 2; the 6 threads will be uniformly distributed on outer circle.

G98;

M14

G0 X105 Z-20 C0;

Position various axes to starting point

M65;

Specifying sign of Main Axis 2 (it is suggested to write M65; writing M63 or M64 is also allowed)

M29 S500;

Rigid tapping specifying, with speed of Main Axis 2 for 500

RPM

G88 X80 H60 R-2P1000 K6 F1000;

G88 is side face rigid tapping circulation; starting point is X105 Z-20 C0, R plane position is X103, hole bottom position is X80, H60 is the position of hole on C-axis, K6 is times and hole bottom pause time is 1 s; through F value and S value instructed, thread pitch is 2.

G80;

Fixed circulation cancellation

M30;

Example 2

Feed per minute mode

G98;	Feed per minute mode
G0 X10 Z-20;	Position X-axis and Z-axis to starting point
M65	Specifying sign for Main Axis 2 (it is suggested to write M65; writing M63 or M64 is also allowed)
M29 S500;	Rigid tapping specifying, with speed of Main Axis 2 for 500 RPM; system number parameter N0.424 sets servo axis controlled by Main Axis 2.
G88X-30R-4P1000F1000;	G88 is side face rigid tapping circulation; starting point is X10 Z-20, R plane position is X6, hole bottom position is X-30 and hole bottom pause time is 1 s; through F value and S value instructed, thread pitch is 2.
G80;	Fixed circulation cancellation
M30;	Program ends

Feed per revolution mode

G99;	Feed per revolution mode
G0 X10 Z-20;	Position X-axis and Z-axis to starting point
M65	Specifying sign for Main Axis 2 (it is suggested to write M65; writing M63 or M64 is also allowed)
M29 S500;	Rigid tapping specifying, with speed of Main Axis 2 for 500 RPM; system parameter N0.424 sets servo axis controlled by Main Axis 2.
G88X-30R-4P1000F2;	G88 is side face rigid tapping circulation; starting point is X10 Z-20, R plane position is X6, hole bottom position is X-30 and hole bottom pause time is 1 s; through F value and S value instructed, thread pitch is 2.
G80;	Fixed circulation cancellation
M30;	Program ends

4.2.14.2 Ordinary (flexible) tapping

Format:

G84 X (U)_ C (H)_ Z (W)_ R_ P_ Q_ F_ K_ M_ ; end face tapping circulation
 G88 Z (W)_ C (H)_ X (U)_ R_ P_ Q_ F_ K_ M_ ; side face tapping circulation
 G80; Fixed circulation cancellation

Instructions:

X_ C_ or Z_ C_ : Hole position data, only valid in designated program segment; hole position data can also specify effective axis of non-X, Z and C axes.
 Z(W)_or X(U)_ : Specifying coordinate value of hole bottom with absolute value or specifying distance form R plane to hole bottom with increment value, only valid in designated program segment..
 R_ : Distance from initial plane to R point; it is the radius value, with direction.
 P_ : Pause time at hole bottom, with unit for 1ms.
 Q_ : Cutting amount for each time; it is the radius value.
 F_ : Cutting feed speed

- K_ : Program executing times
- M_ : M CODE FOR C-AXIS CLAMPING (IF REQUIRED)
- G80 : Fixed circulation cancellation

Note: 1. In general, ordinary tapping mode is only used in tapping on center hold.
 2. In case of selecting ordinary tapping, this code is flexible tapping and tapping axis feed follows rotation of main axis. After hole bottom main axis stop signal M05 is valid, the definite deceleration time is still required before main axis stops rotation. At this time, Z-axis still feeds by following rotation of main axis until main axis stops completely. As a result, in actual processing, hole bottom position of thread should be slightly deeper or shallower than actual programming position. The specific error length is decided by main axis speed upon tapping and main axis brake device.
 Therefore, for safety sake, operator, before G84/G88 tapping, can move trailing plate to safety position and implement G84/G8 dry running (not no-load operation), so as to observe position distance upon hole bottom main axis stop in G84/G88 processing - G84/G88 starting point coordinate difference. Based on that, it is required to modify the program and reserve enough hole depth before G84/G88 processing, for convenience of G84/G88 processing.
 3. In case of ordinary tapping, main axis must be designed with elastic clamp or tool must be designed with variable screw tap.

For example,
 Thread M10×2 in the figure

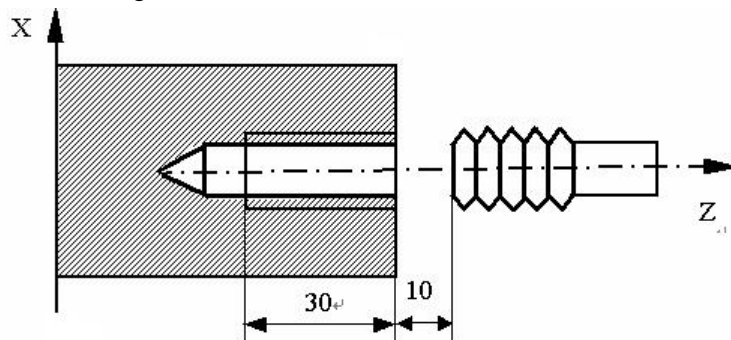

- | | |
|-----------------------|---|
| G98; | Feed per minute mode |
| G0 X0 Z10; | Position X-axis and Z-axis to starting point. |
| M3 S500; | Specify flexible tapping, with main axis speed for 500 RPM |
| G84Z-50R-4P1000F1000; | G84 is end face rigid tapping circulation; starting point is X0 Z10, R plane position is Z6, hole bottom position is Z-50 and hole bottom pause time is 1 s; through F value and S value instructed, thread pitch is 2. |
| G80; | Fixed circulation cancellation |
| M30; | Program ends |
| G99; | Feed per revolution mode |
| G0 X0 Z10; | Position X-axis and Z-axis to starting point |
| M3 S500; | Specify flexible tapping, with main axis speed for 500 RPM |
| G84Z-50R-4P1000F2; | G84 is end face rigid tapping circulation; starting point is X0 Z10, R plane position is Z6, hole bottom position is Z-50 and hole bottom pause time is 1 s; through F value and S value instructed, thread pitch is 2. |
| G80; | Fixed circulation cancellation |
| M30; | Program ends |

4.2.15 Drilling circulation code

Format:

G83 X(U)_C
 G87 Z(W)_C(H)_X(U)_R_P_Q_F_K_M_; side face drilling circulation

Instructions:

X_C_ or Z_C_ : Hole position data, only valid in designated program segment; hole position data can also specify effective axis of non-X, Z and C axes.

Z(W)_ or X(U)_ : Specifying coordinate value of hole bottom with absolute value or specifying distance from R plane to hole bottom with increment value, only valid in designated program segment..

R_ : Distance from initial plane to R point; it is the radius value, with direction.

P_ : Pause time at hole bottom, with unit for 1ms.

Q_ : Cutting amount for each time; it is the radius value.

F_ : Cutting feed speed

K_ : Program executing times

M_ : M CODE FOR C-AXIS CLAMPING (IF REQUIRED)。

G80 : Fixed circulation cancellation

● **Parameters concerned**

0044					RTR			
------	--	--	--	--	-----	--	--	--

RTR: Drilling mode of G83 G87

0: Deep hole drilling, returning to starting point for each time

1: High speed drilling, retreating by distance designated by the number parameter P271 for each time

0271	Retract amount for drilling circulation G83 G87
------	---

[Data scope] : 0-999

For example,

O00002

G98;	Feed per minute mode
G0 X0 Z10;	Positioning X-axis and Z-axis to starting point
M03 S500;	Main axis speed is 500 RPM
G83 Z-60 P1000 F100;	G83 is end face drilling circulation; starting point is X0 Z10, hole bottom position is X0 Z-60, hole bottom pause time is 1 s and cutting feed speed is F100.
G80;	Fixed circulation cancellation
M30;	Program ends

4.2.16 Ellipse instruction code

Format:

G162 X(U)_Z(W)_K_I_Q_F_; clockwise processing

G163 X(U)_Z(W)_K_I_Q_F_; Anticlockwise processing

Instructions:

- X(U) Absolute coordinate of ellipse end point X (relative coordinate for U)
- Z(W) Absolute coordinate of ellipse end point Z (relative coordinate for W)
- K Long axis of ellipse (signified by absolute coordinate value) (value $K>I$)
- I Short axis of ellipse (signified by absolute coordinate value) (value $K>I$)
- Q Anticlockwise included angle between long axis of ellipse and Z-axis (value scope $-360^{\circ}\leq Q\leq 360^{\circ}$)

The angle will be 0° if not input.

I k should not be 0; there will be alarm of it is 0.

There will be alarm if starting point and end point are not on ellipse (ellipse is not constituted and starting point and end point are more than $2 I(A)$).

For example,

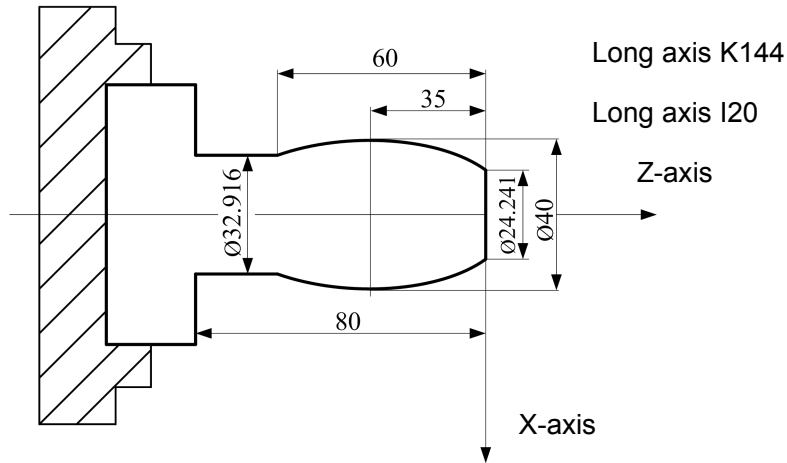

```

M03 S500
G0 X24.241 Z0           Rapidly positioning to starting point
G163 X32.916 W-60 K44 I20 F500   Processing along ellipse
G1 Z-80
G0 X100 Z50 Error! Hyperlink reference invalid
M30
    
```

4.2.17 Parabola instruction code

Note: V1.5 test2.0 and above are valid.

Format:

- G172 X (U)_ Z (W)_ P_Q_ F_; Clockwise processing
- G173 X (U)_ Z (W)_ P_Q_ F_; Anticlockwise processing

Function: Two axes simultaneously execute parabolic interpolation specified by P along from starting point (position before current program segment operation) to end point designated by X(U) and Z(W).

G172 Code movement path is clockwise (rear tool carrier coordinate system)/anticlockwise (front tool carrier coordinate system) parabola from starting point to end point, as shown in Fig. 1.

G173 Code movement path is anticlockwise (rear tool carrier coordinate system)/clockwise (front tool carrier coordinate system) parabola from starting point to end point, as shown in Fig. 2.

Instructions: X(U) Absolute coordinate of parabola end point X (relative coordinate for U)

Z(W) Absolute coordinate of parabola end point Z (relative coordinate for W)

P Absolute value for coefficient of parabola ($y^2 = 2 \cdot p \cdot x$)

Q Anticlockwise included angle long axis of parabola and Z-axis (value scope $-360^\circ \leq Q \leq 360^\circ$)

The angle will be 0° if not input.

F Feed speed; speed variation

Code path:

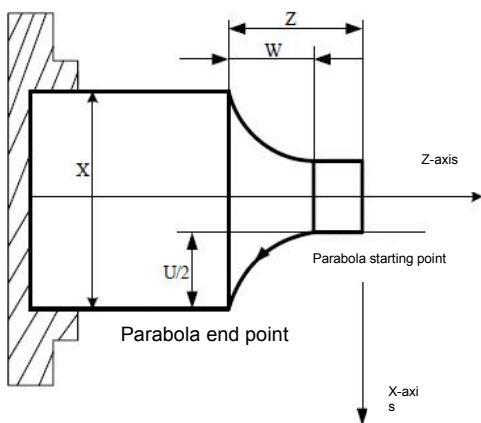

Fig. 1 G172 Path Diagram

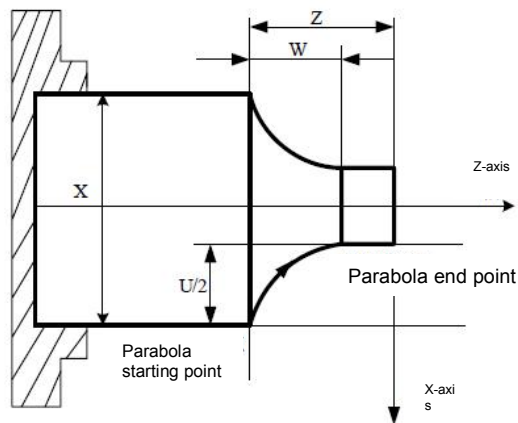

Fig. 2 G173 Path Diagram

Whether it is clockwise or anticlockwise path depends on front/rear tool carrier coordinate system. The system is designed with front tool carrier coordinate system, and subsequent diagrams are hereby programmed. For details, please see Fig. 3.

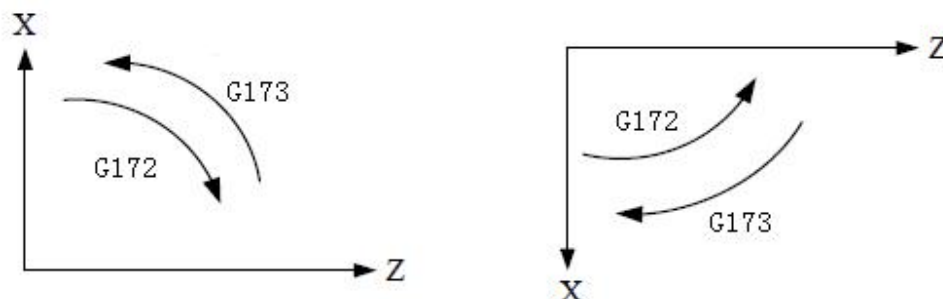

Fig. 3

For example, Write program in Fig. 4 with G173 code, suppose “distance from focus to directrix” P is 2;

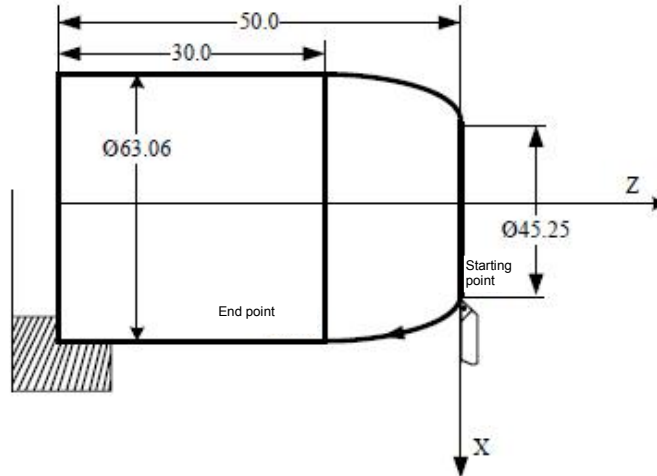

Fig. 4

Program (current point of tool is at starting point):

```
G0 X45.25 Z0
G173 X63.06 Z-20 P2 F300;
```

4.2.18 Polar coordinate interpolation

Function: Polar coordinate interpolation function means converting contour control from programming instruction in rectangular coordinate system into one straight line axis movement (tool movement) and one revolving axis movement (workpiece rotation). The method is used in end face cutting and axial cam grinding of machine tool.

Format: Specifying G12 and G13 in different program segments

G12; Start polar coordinate interpolation mode (make polar coordinate interpolation valid)

```
-----;
-----; Under polar coordinate interpolation mode, G codes which can be
-----; instructed include:
-----; G01: Linear interpolation
-----; G02 and G03: Arc interpolation
-----; G04: pause;
-----; G40, G41, G42: tool tip radius compensation
-----; G65: User macro code
-----; G98, G99: Feed per revolution and feed per minute;
-----;
```

G13; Polar coordinate interpolation mode cancellation

Instructions:

- Polar coordinate interpolation plane
G12 starts polar coordinate interpolation mode and selects a polar coordinate interpolation plane. Polar coordinate interpolation is finished in this plane. The details are shown in the figure below:

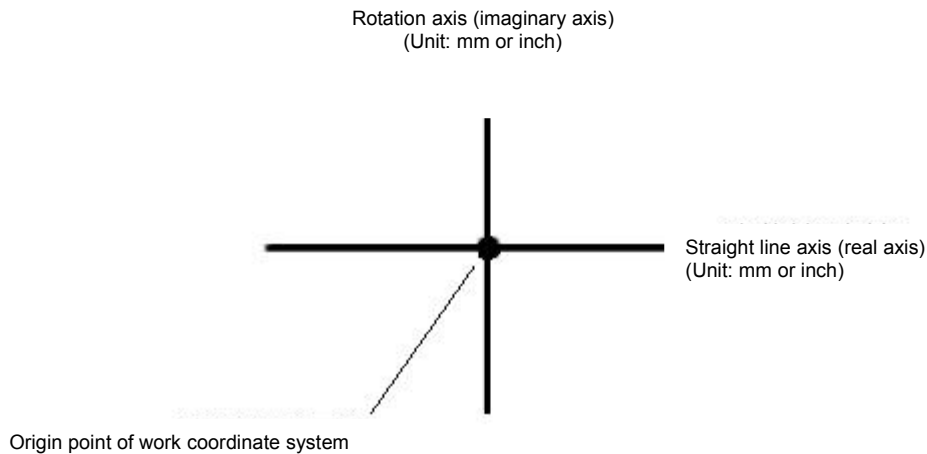

Polar Coordinate Interpolation Plane

Polar coordinate interpolation will be cancelled upon powering on or system reset.

Note: The plane will be cancelled if before G12 instruction; will be recovered if after G13 instruction.

- Movement distance and feed speed of polar coordinate interpolation

Under polar coordinate interpolation mode, program instruction is rectangular coordinate instruction used in polar coordinate plane. Revolving axis address is the address of Axis 2 in the plane. In the plane, Axis 1 is instructed by diameter value or radius value; all revolving axes are the same, i.e. revolving axis is not related to specifications of Axis 1. After instructing G12, virtual axis will be at the position of the coordinate 0. Upon instructing G12, tool position for polar coordinate interpolation will moves from the angle 0.

Feed speed instructed by F is the speed intersecting with polar coordinate interpolation plane (rectangular coordinate system), i.e. relative speed between workpiece and tool.

- Axis movement along non-polar coordinate interpolation plane under polar coordinate interpolation mode
Tool is able to move along these axes, which is not related to polar coordinate interpolation.
- Current position display under polar coordinate interpolation mode

Actual coordinate value display. However, remaining distance in program segment is in accordance with coordinate display in polar coordinate interpolation plane (rectangular coordinate).

Note:

- The first row entering coordinate interpolation mode must specify G01/G02/G03 or current modal is G01/G02/G03; if not, there will be alarm.
- Coordinate system used in polar coordinate interpolation
Before instructing G12, it is required to set a workpiece coordinate system and center of revolving axis is the origin point of this coordinate system. Under G12 mode, coordinate system should not be changed absolutely. (G50, G54- G59, etc.)
- Tool tip radius compensation instruction
Under tool tip radius compensation mode, it is not allowed to start or cancel polar coordinate interpolation mode (G12 or G13). Instructing G12 or G13 is required under tool tip radius compensation cancellation mode.
- Program restart
For program segment under G12 mode, program restart is not allowed.
- When the code G12 has been instructed, tool position of polar coordinate interpolation mode

will move from the angle 0. Therefore, it is necessary to position main axis before polar coordinate interpolation;

- During polar coordinate interpolation, it is not allowed to switch main axis gear. When it is required to switch gear, the system should be under main axis control mode firstly.
- Cutting feed speed of revolving axis

Polar coordinate interpolation means converting tool movement in rectangular coordinate system into tool movement of revolving axis (C-axis) and straight line axis (X-axis). When tool approaches workpiece center, C-axis component for feed speed will get larger; there will be alarm in case of exceeding the maximum cutting feed speed of C-axis (in setting parameter NO96), as shown in the figure below. It is required to lower feed speed in F address instruction or program to make tool (tool center upon using tool tip radius compensation) keep away from workpiece center, for fear that C-axis component exceeds the maximum cutting feed speed of C-axis.

- Radius and radius programming

Revolving axis (C-axis) should be programmed through radius still, even though straight line axis (X-axis) is programmed through diameter.

● **Relevant parameters**

0009							A4TP	
------	--	--	--	--	--	--	------	--

A4TP: Four-axis linkage or not (this parameter is also described in the previous V1.5).

0: No

1: Yes

0039						DIA		
------	--	--	--	--	--	-----	--	--

DIA: Diameter programming or not

0: Radius programming

1: Diameter programming

0043						PLS		PDI
------	--	--	--	--	--	-----	--	-----

PLS: Polar coordinate interpolation offset function used or not

0: No

1: Yes

PDI: Axis 2 in the plane under polar coordinate interpolation mode used upon radius specifying

0: radius specifying

1: Diameter specifying

0530	Straight line axis in polar coordinate interpolation							
------	--	--	--	--	--	--	--	--

[Number meaning] : The corresponding system axis number for straight line axis in polar coordinate interpolation

[Number scope] : 0-5

0531	Revolving axis in polar coordinate interpolation							
------	--	--	--	--	--	--	--	--

[Number meaning] : The corresponding system axis number for revolving axis in polar coordinate interpolation

[Number scope] : 0-5

For example, X-axis (straight line axis) and C-axis (revolving axis)-based polar coordinate

interpolation program (see Fig. 2-12)

X-axis is programmed through diameter programming and C-axis is programmed through radius programming, with programming unit for mm and display unit for “°”.

```

O0001;
N10 T0202
.....;
N100 G00 X150. C0 Z0;
N110 G12;
N120 G42 G01 X80. C0 F200;
N130 C20.0;
N140 G03 X40.0 C40.0 R20.0;
N150 G01 X-40.0;
N160 G03 X-80.0 C20.0 R20.0;
N170 G01 C-20.0;
N180 G03 X-40.0 C-40.0 R20.0;
N190 G01 X40.0;
N200 G03 X80.0 C-20.0 R20.0;
N210 G01 C0;
N220 G40 X150.0;
N230 G13;
N240 Z100.0;
N250 M30;
    
```

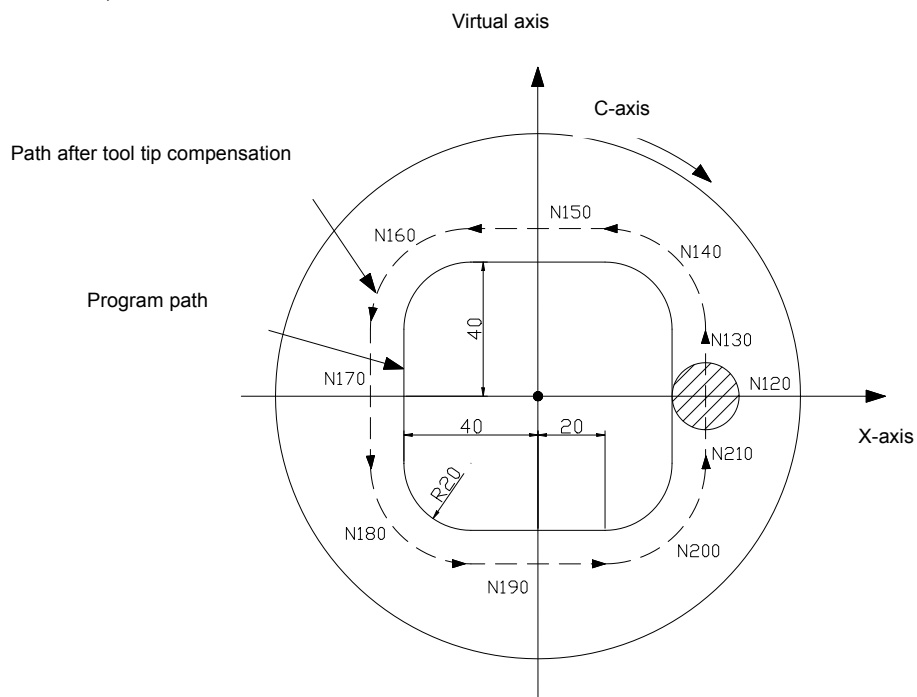

Fig. 2-12

4.2.19 Cylinder interpolation

It is required to convert movement amount of revolving axis specified by angle into distance of straight line axis along external surface inside, so as to finish linear or arc interpolation together with other axes. After interpolation, the distance will be converted to movement amount of revolving axis again.

Cylinder interpolation can be programmed through unfolded plane of cylinder. Therefore, it is very easy to make programming for cylinder cam slot, etc.

Format: Specify G07 in different program segments

G07 IP r; Start cylinder interpolation mode

.....

G07 IP 0; Cancel cylinder interpolation mode

IP: Revolving axis address

r: Cylinder radius

Note: Starting cylinder interpolation is required to be performed under G01 modal; if not, there will be alarm.

Instructions:

- Plane selection

Revolving specified by the parameter 535 or 539 is X, Y or Z-axis or one axis parallel to these axes. For plane selected by specifying G code, revolving axis is the designated straight line axis. To be specific, when revolving axis is one axis parallel to X-axis, G17 must specify a Xp-Yp plane, a plane defined by revolving axis and Y-axis or one axis parallel to Y-axis.

For cylinder interpolation, it is required to set one revolving at most.

- Feed speed

Designated speed under cylinder interpolation is the speed for unfolded cylinder surface.

- Arc interpolation

Under arc cylinder interpolation mode, it is possible to finish arc interpolation with revolving axis and another straight line axis. Arc radius can be instructed by R, with unit not “°” but mm (for metric input) or inch (inch input).

- Tool compensation

In order to execute tool compensation under cylinder interpolation mode, it is necessary to log off the current tool compensation mode before entering cylinder interpolation mode, and then start and stop tool compensation under cylinder interpolation mode. There should be sufficient tool advancement space upon tool compensation establishment and cancellation.

- Cylinder interpolation accuracy

Under cylinder interpolation mode, movement amount of revolving axis instructed by angle is converted into distance of straight line axis on external surface inside on a one-off basis, so as to implement linear interpolation or arc interpolation. After interpolation, the distance will be converted into angle again. For the conversion, movement amount will be rounded to the minimum input increment unit.

Actual movement amount will be unequal to designated movement amount when cylinder radius is small. But the error will not accumulate.

For the reason above, there will be error if manual operating is implemented by engaging switch through absolute value under cylinder interpolation mode.

$$\text{Actual movement amount} = \left[\frac{REV}{2 \times 2\pi R} \times \left[\begin{matrix} \text{Instruction} \\ \text{value} \end{matrix} \times \frac{2 \times 2\pi R}{REV} \right] \right] \times$$

REV: Movement amount of revolving axis per revolution (setting value of No. 1260 parameter)

R: Workpiece radius

[]): Rounded to the minimum input increment unit

Limits:

- Arc radius specifying under cylinder interpolation mode
Arc radius cannot be specified by letter address I, J or K under cylinder interpolation mode.
- Arc interpolation and tool tip radius compensation
Arc interpolation cannot be correctly completed under cylinder interpolation mode if cylinder interpolation mode begins upon tool tip radius compensation which has been applied.
- Positioning
Under cylinder interpolation mode, it is not allowed to specify positioning operating (including positioning operating for rapid movement circulation, such as G28 and G80-G89). Cylinder interpolation mode must be cancelled before designated position. Cylinder interpolation (G07) cannot be executed under positioning mode (G00).
- 坐 Coordinate system setting
Under cylinder interpolation mode, it is not allowed to specify workpiece coordinate system G50.
- Cylinder interpolation mode setting
Under cylinder interpolation mode, it is not allowed to reset cylinder interpolation mode. Cylinder interpolation mode must be eliminated before resetting cylinder interpolation mode.
- Fixed drilling circulation during cylinder interpolation
It is not allowed to specify fixed drilling circulation G81- G89 during cylinder interpolation.

Relevant parameters

0009	DTP						A4TP	
------	-----	--	--	--	--	--	------	--

A4TP: Four-axis linkage or not (this parameter is also described in the previous V1.5.

0: No

1: Yes

DTP: Rotation axis input type in cylinder interpolation

0: angle

1: unfolded plane distance

0535	Set Axis 1 as axis in basic coordinate system
------	---

[Number meaning] : The corresponding system axis number for straight line axis in cylinder interpolation

[Number scope] : 0-5

0536	Set Axis 2 as axis in basic coordinate system
------	---

[Number meaning] : The corresponding system axis number for straight line axis in cylinder interpolation

[Number scope] : 0~5

0537	Set Axis 3 as axis in basic coordinate system
------	---

[Number meaning] : The corresponding system axis number for straight line axis in cylinder interpolation

[Number scope] : 0~5

0538	Set Axis 4 as axis in basic coordinate system
------	---

[Number meaning] : The corresponding system axis number for straight line axis balanced to revolving axis in cylinder interpolation

5: Balanced to Axis 1; 6: Balanced to Axis 2; 7: Balanced to Axis 3

[Number scope] : 0-7

0539

Set Axis 5 as axis in basic coordinate system

[Number meaning] : The corresponding system axis number for straight line axis balanced to revolving axis in cylinder interpolation

5: Balanced to Axis 1; 6: Balanced to Axis 2; 7: Balanced to Axis 3

[Number scope] : 0-7

Note: Parameters PA0535, PA 0536 and PA 0537 are corresponding axis numbers for basic coordinate system; default value is 1, 2 and 3.

Parameters PA538 and PA539 are corresponding rotation axes of basic coordinate system and corresponding system axis for straight line axis balanced to revolving axis in cylinder interpolation. Setting value is decided according to coordinate plane; G17 plane is set as 5 or 6, G18 plane is set as 5 or 7 and G19 plane is set as 5 or 7. Default plane of ordinary machine tool is G18 pane, where Axis 5 is rotation axis and PA539 is set as 5.

For example,

```

000001;
N0001 G0 Z100;
N0002 G0 X100
N0003 M14;           (Switching main axis to position
control mode)
N0004 G01 C0;       (C-axis returns to zero; cylinder
interpolation cannot be started
unless under G01 modal.)
N0005 G07 C50;     (R50Starting cylinder interpolation
cylinder radius)
N0006 G01 G42 Z120.0 F300;
N0007 C30.0;
N0008 G03 Z90.0 C60.0 R30.0;
N0009 G01 Z70.0;
N0010 G02 Z60.0 C70.0 R10.0;
N0011 G01 C150.0;
N0012 G02 Z70.0 C190.0 R75.0;
N0013 G01 Z110.0 C230.0;
N0014 G03 Z120.0 C270.0 R75.0;
N0015 G01 C360.0;
N0016 G40 Z100.0;
N0017 G07 C0;     (Canceling cylinder interpolation)
N0018 M15;       (Switching main axis to speed control mode)
N0019 M30;
    
```

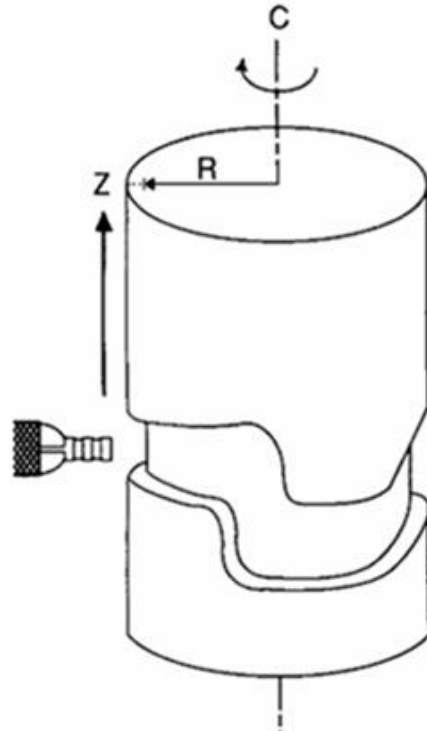

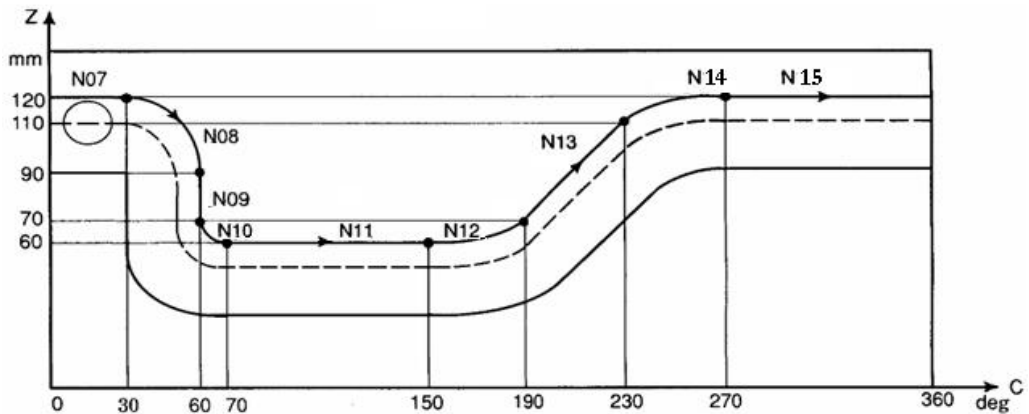

The figure above is side face folded diagram in the program example. According to the diagram, after movement amount of revolving axis (C-axis) specified by angle is converted into straight line axis distance of cylinder along surface, interpolation formed through revolving axis and another straight line axis (Z-axis) can be regarded as interpolation under Z-X plane coordinate system in G18 plane.

4.2.20 Polygon cutting

Polygon cutting means polygon processing by using workpiece and tool to determine ratio rotation.

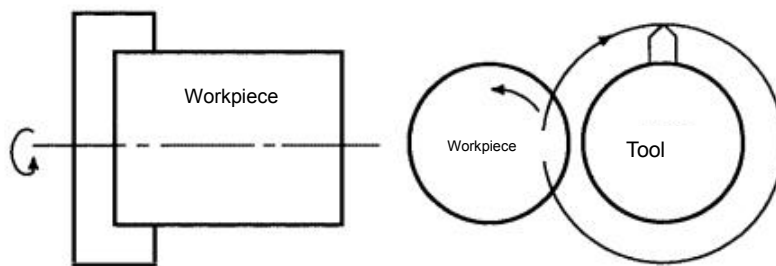

Fig. 4-2-20-1

Square or hexagon workpiece can be processed by changing gyration ratio of workpiece and tool or number of tool tips. It can reduce processing time, compared with method for processing polygon by using C-axis and X-axis in polar coordinate. But the shape processed is not accurate polygon. Polygon cutting is used in processing square or hexagon screw or bolt.

Control axis composition:

- Axis 1: X-axis
- Axis 2: Z-axis
- Axis 3: Y-axis (Tool axis, secondary control axis)
- Axis 4: C-axis (Tool axis, main control axis)

Instruction format: Specifying G251 and G250 in different program segments

```
G251 P_Q_;      Polygon turning start
.....
G250;          Polygon side cutting cancellation
```

Instructions:

- P, Q: Rotation rate of main axis and Y-axis
- Value scope: 1-1, 000 for P and Q, without decimal point

Y-axis will have positive rotation when Q is positive value; Y-axis will have reverse rotation when Q is negative value.

For polygon turning, tool rotation will be controlled by axis controlled by CNC. The rotation axis will be called as Y-axis in following description.

Controlled by G251 instruction, Y-axis enables rotation speed of workpiece and tool mounted on main axis (instructed by S) in accordance with designated ratio.

For example, rotation rate of workpiece (main axis) and Y-axis is 1:2 and Y-axis has positive rotation. G251 P1 Q2

The system will start to detect transfer signal sent by position encoder installed on main axis when G251 specifies simultaneous startup. After detecting single-transfer signal, Y-axis gyration ratio will be controlled according to designated gyration ratio (P: Q), i.e. controlling Y-axis rotation to make main axis and Y-axis gyration have the relationship of P: Q. The relationship will be kept until polygon cutting cancellation instruction (G250 or reset operating) has been executed. Y-axis rotation direction depends on code Q and is not affected by rotation direction of position encoder.

In case of specifying G250, synchronization of main axis and Y-axis will be cancelled and Y-axis will stop. Under the circumstances below, the synchronization will be cancelled:

- 1) Power interruption
- 2) Emergency stop
- 3) Servo alarm
- 4) Reset
- 5) Alarm

Principle of polygon turning:

Details on polygon turning are as follows. In the figure below, tool radius and workpiece radius is respectively A and B and angle speeds of tool and workpiece are respectively α and β ; origin point of XY coordinate system is assumed as workpiece center. For simplifying description, it is supposed that tool center is located in the part of $P_0(A,0)$ at workpiece edge and tool tip moves from the position $P_{to}(A-B, 0)$.

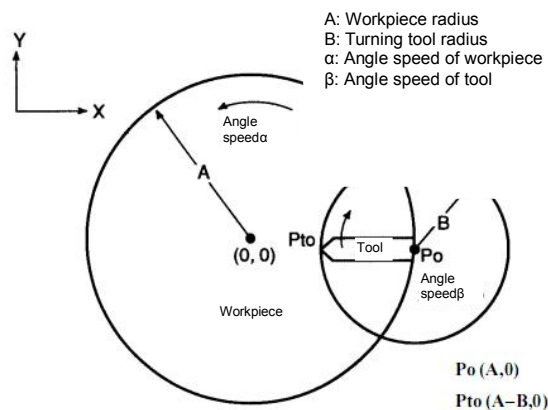

Fig. 4-2-20-2

Under this circumstance, the time t and rear tool tip position $P_t(X_t, Y_t)$ are signified by Formulate 1 below:

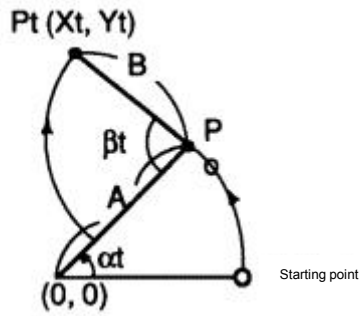

Fig. 4-2-20-3

$$X_t = A \cos \alpha t - B \cos(\beta - \alpha)t \quad (\text{Formula 1})$$

$$Y_t = A \sin \alpha t + B \sin(\beta - \alpha)t$$

Formula 1 should be modified as follows suppose rotation ratio of workpiece and tool is 1: 2, i.e. $\beta = 2\alpha$:

$$X_t = A \cos \alpha t - B \cos \alpha t = (A - B) \cos \alpha t \quad (\text{Formula 2})$$

$$Y_t = A \sin \alpha t + B \sin \alpha t = (A + B) \sin \alpha t$$

Formula 2 means drawing an ellipse with long axis as $A+B$ and short axis as $A-B$. It is thus can be seen that square can be processed by using tool shown below, suppose tool is mounted 180° symmetric position.

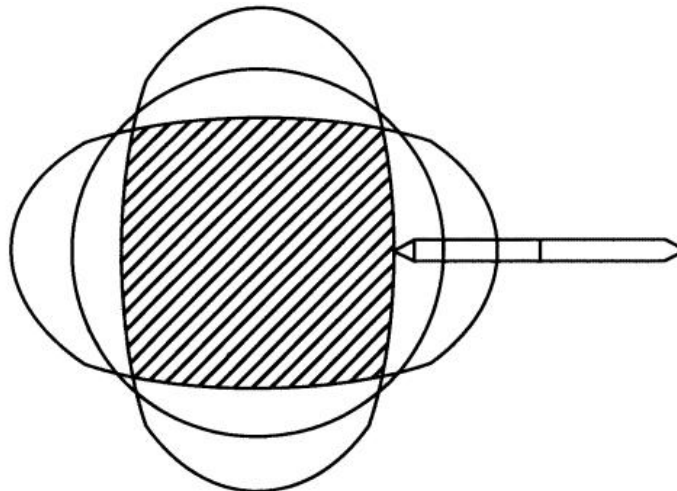

Fig. 4-2-20-4

Hexagon shown below will be processed if three knives are installed with 120° spacing.

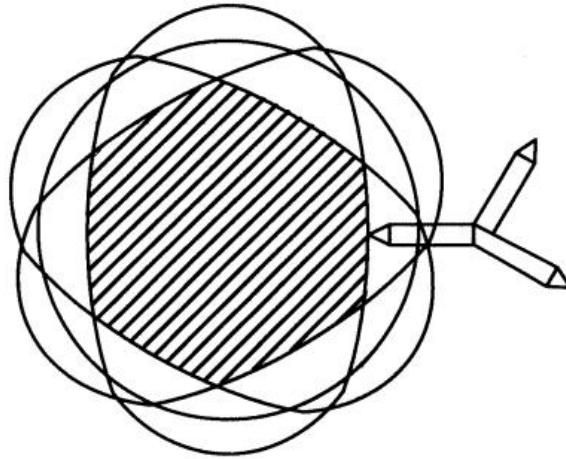

Fig. 4-2-20-4

Note 1:

- 1) After executing G251, Y-axis, which is different from control axes, cannot specify movement instructions such as Y_. It is because that Y-axis has no need for axis movement instruction; to be specific, when G251 (polygon turning mode) is specified, it is only required to control synchronous rotation of Y-axis and main axis and the speed has fixed ratio with main axis speed. However, in case of instructing G250 (polygon turning mode cancellation instruction), it is necessary to use reference position to return to instruction (G28Y0), with the reason that position for Y-axis rotation stop is changeable. It will go wrong if starting position for tool rotation is changeable, such as the condition for the same graphics having fine processing after rough machining. Definition of Y-axis G28Y0 is the same with orientation instruction of main axis. For other axes which are different from manual reference point return, deceleration switch is not required to be detected when G28 returns to reference point; but for Y-axis which is the same with manual reference point return, it is required to detect deceleration switch upon executing reference point return. In order to make processing shape the same with that of the last one, tool and workpiece must be in the position the same with that of the last processing when tool starts rotation; tool will start rotation after detecting single-transfer signal of position encoder on main axis.
- 2) Upon polygon turning, Y-axis controlling tool rotation should be Axis 4; but Axis can also be used by setting the parameter 384, and under this time, the axis must be called as C-axis.
- 3) Upon Y-axis movement, display of machine tool coordinate value (MECHINE) varies within 0-parameter setting value (movement amount per revolution) in axis position display. Absolute value or machine tool indicated number will not be updated.
- 4) It is not allowed to install absolute position detector on Y-axis.
- 5) The maximum speed of tool rotation axis should not exceed value set by No. 0385.
- 6) Gear ratio of tool rotation axis should be set in the system.
- 7) After starting synchronization, cutting processing should not be started until speeds of main axis and Y-axis are steady.

Note 2: Gear ratio on tool rotation axis (i.e. Y-axis) should be set in the system.

● **Relevant parameters**

0009							A4TP	
------	--	--	--	--	--	--	------	--

A4TP: Four-axis linkage or not (this parameter is also described in the previous V1.5).

0: No

1: Yes

0384	Control axis number of tool rotation axis for polygon processing
------	--

[Number meaning] : Control axis number of tool rotation axis for polygon processing

[Number scope] : 0-5

0385	peed upper limit of tool rotation axis for polygon processing
------	---

[Data meaning] : Speed upper limit of tool rotation axis for polygon processing

[Value scope] : 1-2000

For example,

O0010	
T0101	
M3 S100	Workpiece rotation speed: 100 revolutions
G0 X50 Z0	Rapid positioning
G0 Y0	Tool rotation axis returns to zero
G251 P1 Q2	Tool rotation axis synchronization starts (rotation speed: 200 revolutions)
G01 Z-10 F100	Z-axis feed
X80	X-axis retreat
G250	Tool rotation axis synchronization cancellation and tool operation stop
G0 Z100	Z-axis retreats to safety position
M30	

4.3 Reference Point G Code

Reference point is a fixed point on machine tool; with reference point return function, tool can move to the position very easily.

For reference point, there are three code operating types, as shown in Fig. 4-3-1. With G28, tool can pass through middle point and automatically move to reference point along designated axis in code.

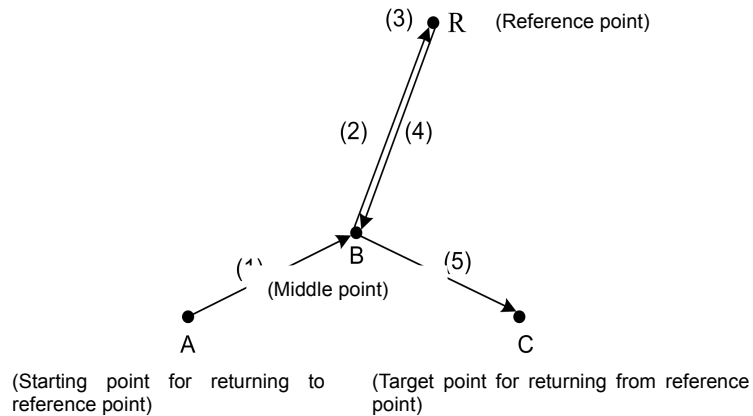

Fig. 4-3-1

4.3.1 Automatic return to machine zero (G28)

Format: G28 X(U)_ Z(W)_;

Function: With the code, axis instructed can return to machine zero through middle point specified by X (U) and Z (W). In the code, one or two axes can be specified.

Table 4-3-1-1

Instruction	Function
G28 X(U)	X-axis returns to machine zero and Z-axis keeps at original position.
G28 Z(W)	Z-axis returns to machine zero and X-axis keeps at original position..
G28	Keeping at original position (the system will give 166 alarm)
G28 X(U)___Z(W)	X-axis and Z-axis return to machine zero simultaneously.

Instructions: Instruction process (for action process, please see Fig. 4-3-1-1):

- (1) Rapidly move from current position to middle point in the instruction (A point →B point)
- (2) Rapidly move from middle point to machine zero (B point→ R point)
- (3) If the system is not in non-machine tool locking state, return to machine zero will end, zero indicator will be on and machine tool coordinate will zero out.

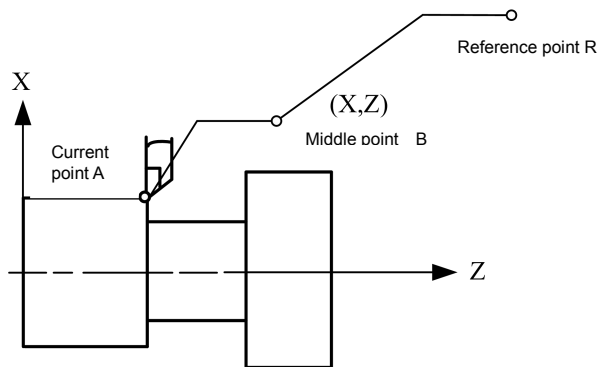

Fig. 4-3-1-1

- Note:**
1. Upon instructing G28, movement from middle point to machine zero is the same with manual return to machine zero, if manual return to machine zero has not been performed yet after powering on.
 2. During the process from A point→ B point, two axes are positioned respectively at the independent speed. Therefore, the path is not straight line.
 3. This function is unavailable if machine tool is not designed with machine zero.

4.4 Single Fixed Circulation Code

In some special rough turning processing processes, repeated cutting is required in the same processing route due to huge cutting workload. At this time, fixed circulation function can be used, with which, processing required to be completed through multiple program segments originally can be completed with one program segment only. Besides, during repeated cutting, it is only required to change corresponding value, which goes a good way with program simplification. Single-type fixed circulation code includes axial cutting circulation G90, thread cutting circulation G92 and radial cutting circulation G94.

Descriptions in diagrams below are specified by diameter; where specified by radius, it is required to replace U with U/2 and replace X with X/2.

4.4.1 Axial cutting circulation (G90)

Format: G90 X(U)__ Z(W)__ R__ F__;

Function: Cylindrical and conical surface single circulation processing will be implemented when this code is executed. After circulation, tool will return to starting point. The imaginary line (R) in Fig. 4-4-1-1 and Fig. 4-4-1-2 signifies rapid movement and real line (F) means cutting feed. Numeric symbol behind the address U in increment program depends on X direction of Path 1 and numeric symbol behind the address W depends on Z direction of Path 2.

Instructions: Absolute coordinate value of circulation end point, with unit for mm;

U, W: Movement amount from circulation end point to circulation starting point, with unit for mm;

R: Radius difference at conical surface cutting starting point and cutting end point, with unit for mm;

F: Resultant feed speed of X-axis and Z-axis during circulation; it is a modal code.

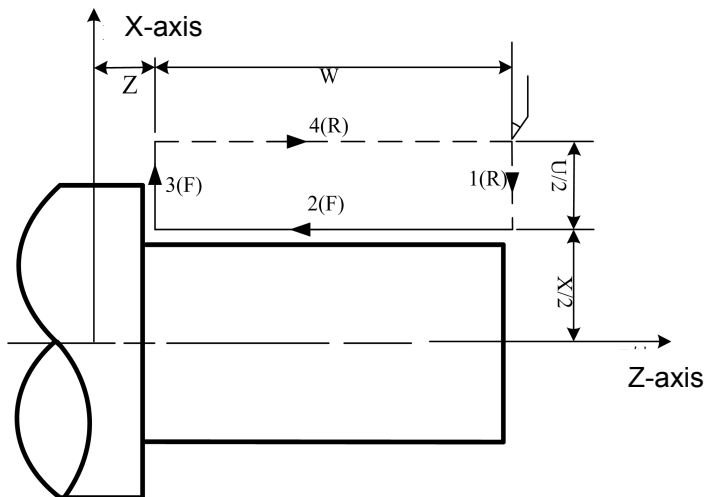

Fig. 4-4-1-1

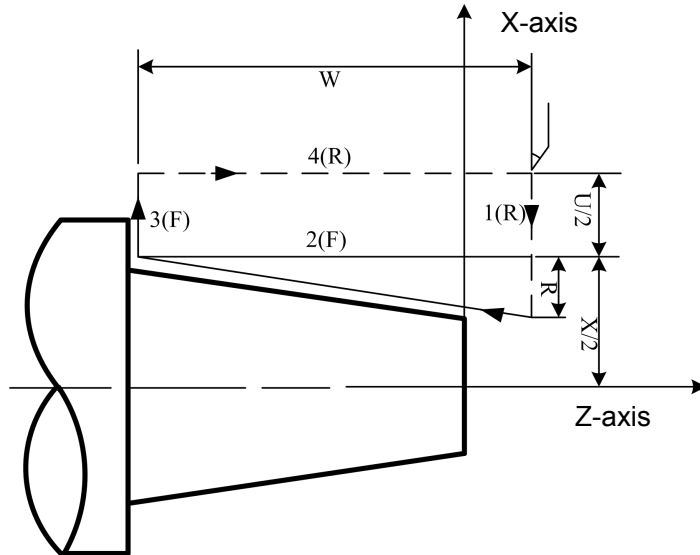

Fig. 4-4-1-2

G90 code has four paths according to different tool start points, as shown in Fig. 4-4-1-3.

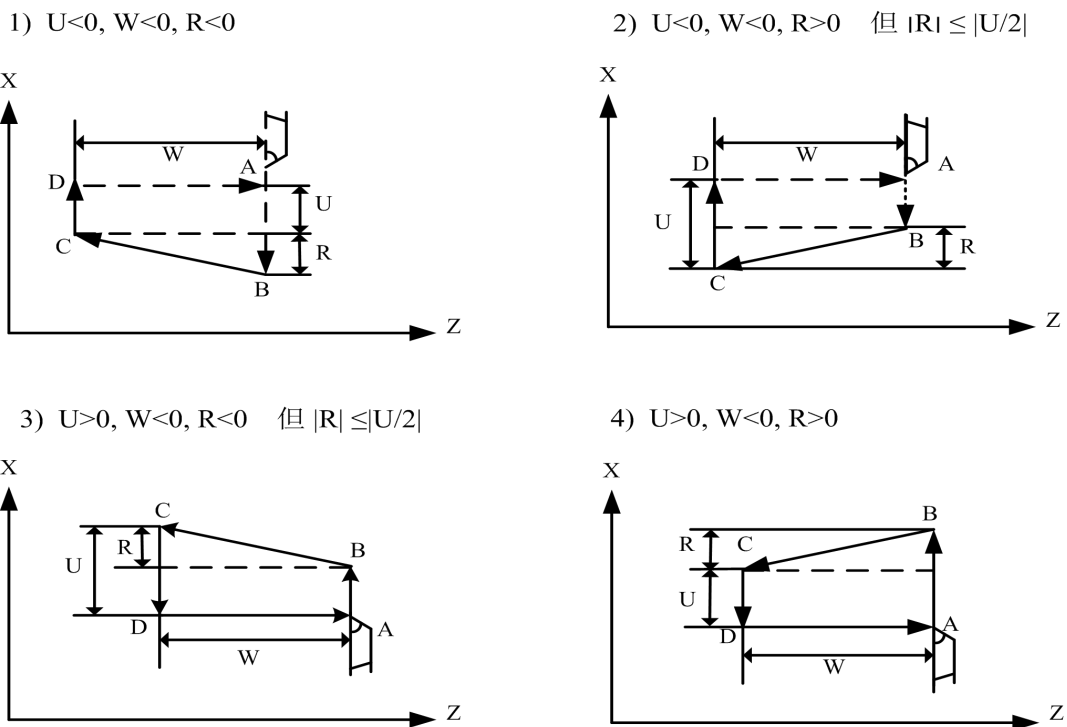

Fig. 4-4-1-3 G90 Code Operation Path

For example, write program in Fig. 4-4-1-4 through the code G90.

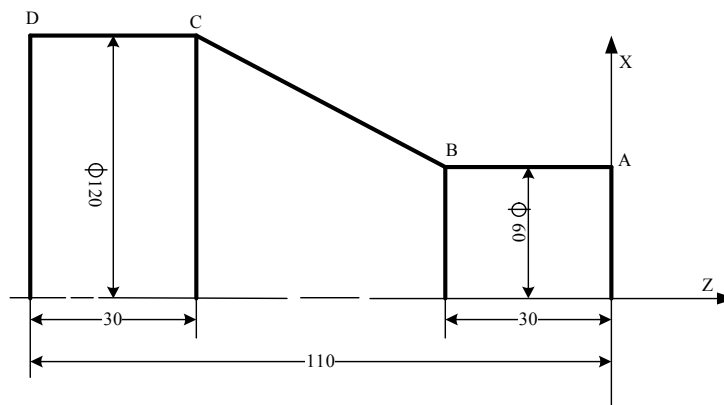

Fig. 4-4-1-4

Program:

```

O0001;
M3 S300;
G0 X130 Z5;
G90 X120 Z-110 F200; (C→D)
X60 Z-30; (A→B)
G0 X130 Z-30;
G90 X120 Z-80 R-30 F150; (B→C)
M5 S0;
M30;

```

4.4.2 (G94) Radial cutting circulation (G94)

Format: G94 X(U)__ Z(W)__ R__ F__;

Function: End face single circulation processing will be implemented when this code is executed. After circulation, tool will return to starting point. R in Fig. 4-4-2-1 and Fig. 4-4-2-2 signifies rapid movement and F means cutting feed. Numeric symbol behind the address U in increment program depends on X direction of Path 2 and numeric symbol behind the address W depends on Z direction of Path 1.

Instructions: Absolute coordinate value of circulation end point, with unit for mm;

U and W: Movement mount from circulation end point to circulation starting point, with unit for mm.

R: Coordinate component in Z-axis direction for end face cutting starting point to end point, with unit for mm;

F: Resultant feed speed of X-axis and Z-axis during circulation; it is a modal code.

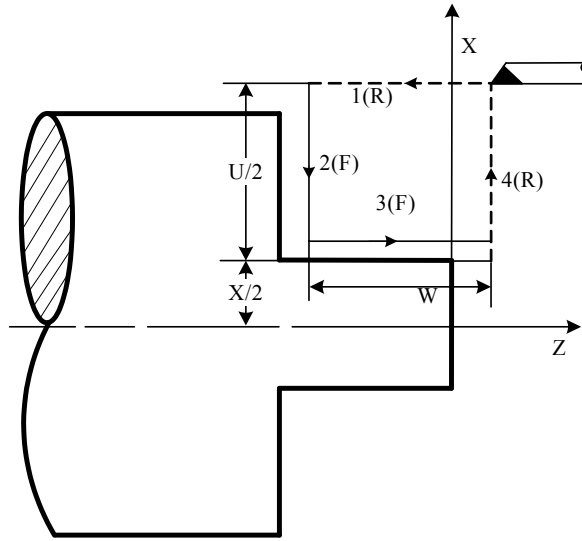

Fig. 4-4-2-1

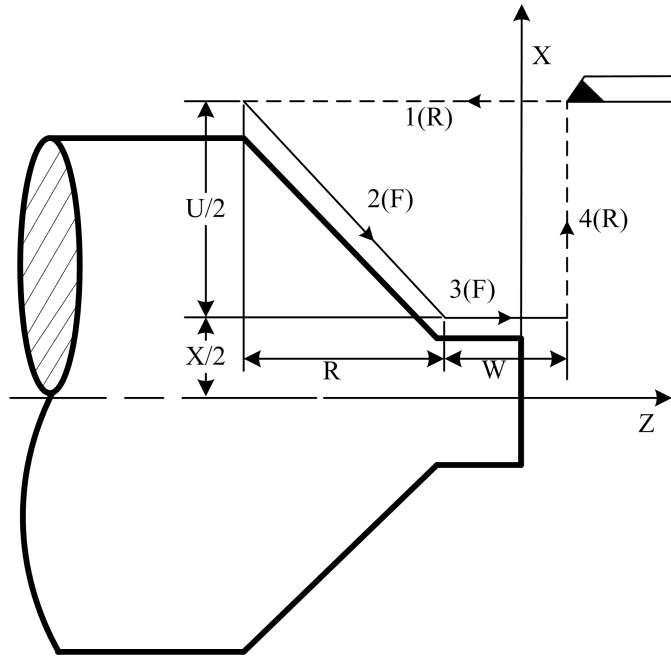
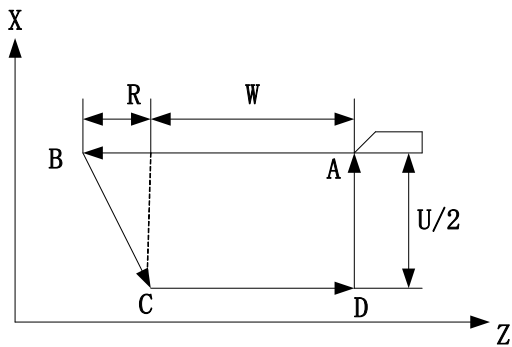

Fig. 4-4-2-2

G94 code has four paths according to different tool start points, as shown in Fig. 4-4-2-3.

1) $U < 0, W < 0, R < 0$



2) $U < 0, W < 0, R > 0 (|R| \leq |W|)$

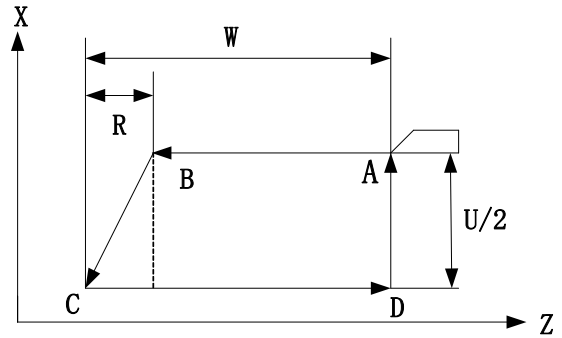

3) $U > 0, W < 0, R > 0 (|R| \leq |W|)$

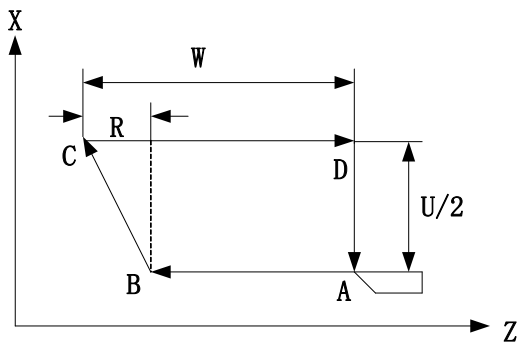

4) $U > 0, W < 0, R < 0$

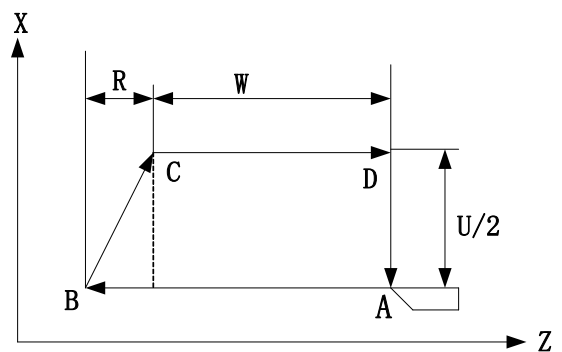

Fig. 4-4-2-3

For example, write program in Fig. 4-4-1-4 through the code G904.

Program:

```
O0002;
M3 S1;
G0 X130 Z5;
G94 X120 Z-110 F100; (D→C)
G0 X120 Z0;
G94 X60 Z-30 R-50; (C→B→A)
M5 S0;
M30;
```

4.4.3 Thread cutting circulation (G92)

Format:

G92X(U) Z(W) J_K F_L; (metric thread)

↑
Designated thread pitch (F)

G92X(U) Z(W) J_K I_L; (Inch thread)

Designated thread pitch (threads/inch)

Function: Equal pitch straight thread and taper thread single circulation thread processing will be implemented when this code is executed. After circulation, tool will return to starting point.

Retracting groove is not required upon thread cutting. J and k are vanishing length of X-axis and Z-axis respectively. The imaginary line (R) in Fig. 4-4-3-1 and 4-4-3-2 signifies rapid movement and real line (F) means cutting feed. The setting values J and K (if have) will execute vanishing of X-axis and Z-axis; when user is not required for thread vanishing length set by J and K, the system will execute vanishing length = pitch of setting value X 0.1 X for the parameter P473. When J is omitted, vanishing in long axis direction will be performed as per K and vanishing in short axis direction will be performed as per setting value of the parameter NO.473. In case of omitting K, vanishing will be performed as per K=J. When J=0 or J=0 and K=0, there will not be vanishing; when J≠0 and K=0, vanishing will be performed as per K=J; when J=0 and K≠0, there will not be vanishing.

Instructions: Coordinate value of circulation end point, with unit for mm;

U, W: Movement mount from circulation end point to circulation starting point, with unit for mm;

J: Vanishing length in X direction, without symbolic number; value scope: 0-9,999 mm.

K: Vanishing length in Z direction, without symbolic number; value scope: 0-9,999,999 mm.

R: Difference of X-axis absolute coordinates for cutting starting point and cutting end point (radius value); in case of inconformity for symbols of R and U, the requirement $|R| \leq |U/2|$ should be met;

F: Metric thread pitch, with value scope for 0.001-500 mm; it is a modal code;

I: Threads per inch of inch thread, with value scope for 0.06-25,400 thread/inch; it is modal code;

L: Number of threads, with value scope 1-99 pcs; it is a modal code; if not specified, it will have default value as 1`;

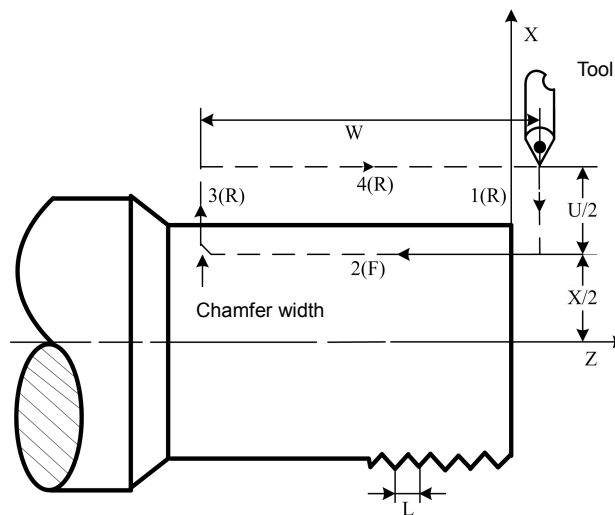

Fig. 4-4-3-1

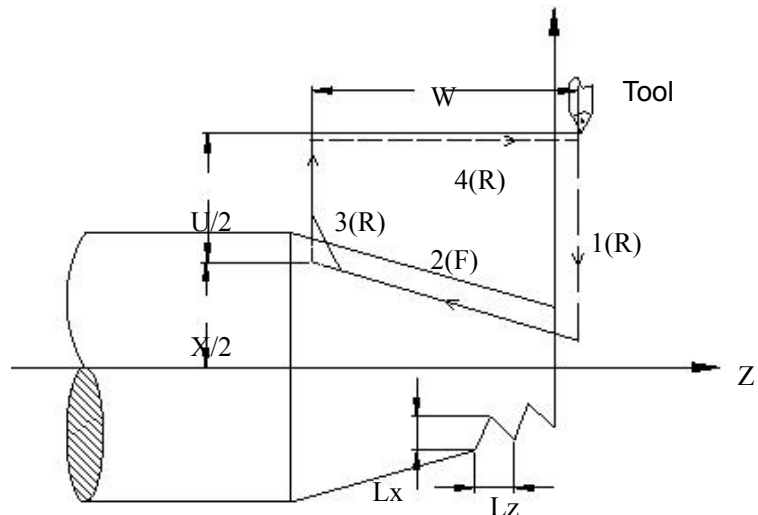

Fig. 4-4-3-2

Note:

1. Precautions of thread cutting are the same with G32 thread cutting; please see 4.2.13 in this Manual.
2. During thread cutting, circulation should not be stopped until Action 3 ends if there is feed hold signal input.
3. Within thread pitch scope, main axis speed limit and other factors should be the same with thread cutting of holding signal;
4. While G92 is executing straight thread, there will be alarm if tool starting point of G92 is the same with thread end point in X direction, because it is unable to recognize whether thread belongs to inner thread or outer thread.
5. For R value scope in G92, please see Fig. 4-4-1-3.
6. The system will have 45° vanishing when any one of J and K is set as 0 or not specified.

For example, write component program in Fig. 4-4-3-3 through the code G90 firstly and then process thread with the code G92.

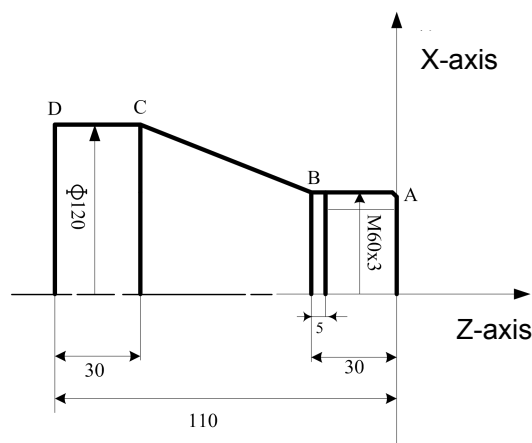

Fig. 4-4-3-3

Program:

```
O0001;
M3 S300;
G0 X150 Z50;
T0101;           (Turning tool of outer circle)
G0 X130 Z5;
G90 X120 Z-110 F200;   (C→D)
X60 Z-30; (A→B)
G0 X130 Z-30;
G90 X120 Z-80 R-30 F150; (B→C)
G0 X150 Z150;
T0202;           (chaser)
G0 X65 Z5;
G92 X58.5 Z-25 F3;     (Thread processing; four-tool cutting)
X57.5 Z-25;
X56.5 Z-25;
X56 Z-25;
M5 S0;
M30;
```

4.4.4 Precautions for Single Fixed Circulation Code

- 1) In single fixed circulation, the data X(U), Z(W) and R are modal values. Where the new X(U), Z(W) and R are not specified, all data specified before are valid;
- 2) In single fixed circulation, X(U), Z(W) and R data will be eliminated when non-modal G codes other than G04 or codes in Group 01 other than G90, G92 or G94 are specified.
- 3) The fixed circulation will not be repeated when there is only non-moving code program segment behind G90, G92 or G94 program segment.

(Example) N003 M3;

```
...
...
N010 G90 X20.0 Z10.0 F2000;
N011 M8; (no repeated G90 execution)
...
...
```

- 4) Under fixed circulation state, fixed circulation can be simultaneously performed with M, S and T functions if M, S and T are specified; please instruct fixed circulation again if fixed circulation is cancelled after instructing M, S and T resulted from the instructions G00 and G01.

(Example) N003 T0101;

```
...
N010 G90 X20.0 Z10.0 F2000;
N011 G00 T0202;
N012 G90 X20.5 Z10.0;
```

4.5 Compound Fixed Circulation Code

In order to simplify fixed programming, the system provides six compound fixed circulation codes: axial rough turning circulation G71, radial rough turning circulation G72; closed cutting circulation G73; fine processing circulation G70; axial grooving circulation G74; radial grooving circulation G75 and multi-thread cutting circulation G76. With this kind of compound circulation codes, the system will calculate processing route and tool feed times automatically only by specifying fine processing route and depth of cut of rough machining.

4.5.1 Axial rough turning circulation (Type I of G71)

Format: G71u(Δ d)R(e);

G71 P(NS) Q(NF) U(Δ u) W(Δ w)F S T ;

N(NS)G0/G1 X(U) ;

. ;

. . . . F;

. . . . S;

. . . . T;

.

N(NF). ;

} Program segment of fine processing

Function: The system will calculate rough machining route automatically according to workpiece fine processing route, depth of cut and tool advancement mount and retreat mount given by NS-NF program segment, as shown in Fig. 4-5-1-1, so as to realize cutting with action parallel to Z-axis. Non-molded bars can be shaped at a time.

Instructions: Δ d: Depth of cut for each time, without symbol. Cutting direction depends on AA' direction (radius specifying), with value scope for 0.001 mm – 99,999.999mm. It is a modal mode and will be valid until next specifying. In addition, it can also be specified by the data parameter P462 and parameter value can be changed according to program instruction.

e: Retreat amount (radius specifying), with unit for mm and value for 0 mm-99,999.999 mm. It is a modal code and will be valid until next specifying. It can also be set by the data parameter P463 and parameter value can be changed in case of using program instruction.

NS: Sequence number of the first program segment for fine processing route program segment cluster.

NF: Sequence number of the first program segment for fine processing route program segment cluster.

Δ u: Distance and direction of fine processing allowance in X-axis direction, with value scope for -999,999.99-999,999.99mm.

Δ w: Distance and direction of fine processing allowance in Z-axis direction, with value scope for -999,999.99-999,999.99mm.

F: Cutting feed speed, with value scope for 1mm/min-6,000mm/min for feed per minute and 0.001mm/r-500mm/r for feed per revolution.

S: Speed of main axis;

T: Tool and tool offset number

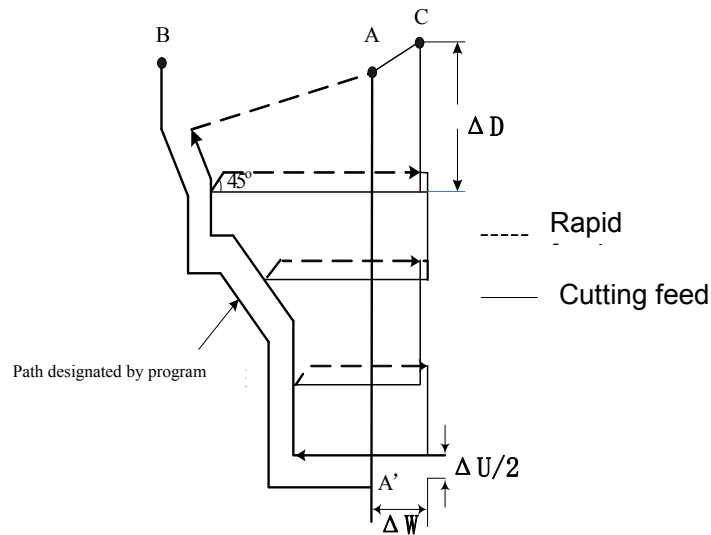

Fig. 4-5-1-1 G71 Code Operation Path

1. Both Δd and Δu are specified by the same address U; the difference is whether to specified P or Q according to program segment.
2. Circulation action is implemented through G71 code specified by P and Q.
3. In G71 circulation, F, S and T functions in program segment of the sequence numbers NS-NF are invalid and should be ignored. G71 program segment or F, S and T specified previously are valid. In program segments of sequence numbers NS-NF, F, S and T are only open to G70 code circulation.
4. Where there is constant line speed control selection function, G96 or G97 in program segment of the sequence numbers NS-NF is invalid and those specified by G71 or pervious program segment are valid.
5. G71 code path has four types according to different cutting directions, as shown in Fig. 4-5-1-2. But cutting is performed according to tool movement parallel to Z-axis no matter which kind of type it is. Δu and Δw symbols are as follows:

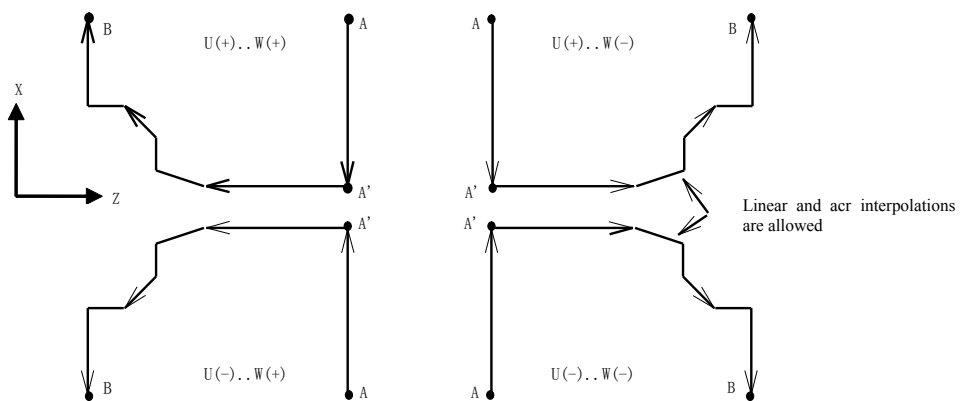

Fig. 4-5-1-2

6. In NS program segment of the sequence number A-A', it is only allowed to use G00 or G01 for specifying and Z-axes of A point and A' point should be consistent.
7. In A'-B, X and Z address values must be of monotonic increasing or decreasing and the path must be monotonic;
8. In program segment of the sequence numbers NS-NF, it is not allowed to invoke subprogram.
9. In the sequence numbers NS-NF, 100 program segments can be entered at most; the system will give alarm ERR137 when number of program segments is beyond 100.

For example, write component program in Fig. 4-5-1-3 through compound fixed circulation G71.

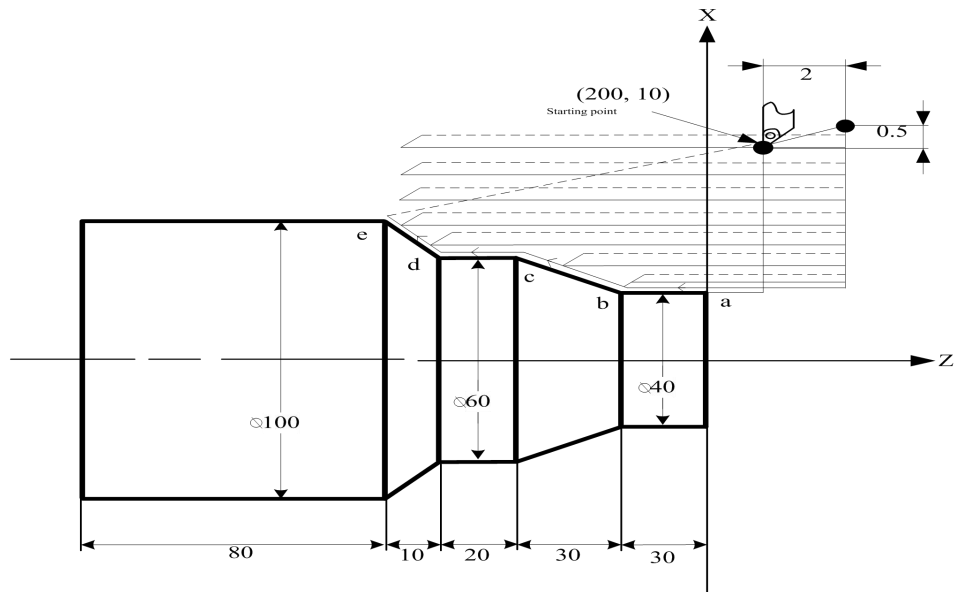

Fig. 4-5-1-3

Program:

```

O0001;
N010 G0 X220.0 Z50;           (Positioning to safety position)
N020 M3 S300;                 (Anticlockwise rotation of main axis, with speed for 300r/min)
N030 M8;                       (Enable cooling mode)
N040 T0101;                   (Invoke rough turning tool)
N050 G00 X200.0 Z10.0;       (Rapid positioning; approaching workpiece)
N060 G71 U0.5 R0.5;          (Depth of cut for each time 1mm [diameter]; retract by 1mm
                               ([diameter])

N070 G71 P080 Q120 U1 W2.0 F100 S200; } (For a→d rough turning, allowance in X direction is
                                         1mm and allowance in Z direction is 2mm)
N080 G00 X40.0;                } (Position to X40)
N090 G01 Z-30.0 F100 S200; (a→b) }
N100 X60.0 W-30.0; (b→c)       } Fine processing route a→b→c→d→program segment
N110 W-20.0; (c→d)
N120 X100.0 W-10.0; (d→e)
N130 G00 X220.0 Z50.0;        (Rapidly retreat to safety position)
N140 T0202;                    (Import No. 2 fine processing tool and execute No. 2 tool offset)
N150 G00 X200.0 Z10.0;        (Position to circulation starting point instructed by G70)
N160 G70 P80 Q120;            (Fine turning for a--- e)
N170 M05 S0;                  (Close main axis and stop speed)
N180 M09;                     (Close cooling)
N190 G00 X220.0 Z50.0 T0100;  (Return to safety position rapidly; change back into
                               benchmark tool and eliminate tool offset)
N200 M30;                     (Program ends)
    
```

4.5.2 Groove circulation processing (Type II of G71)

Type II of G71: Different from Type I, appearance outline along X-axis has not need for monotonic increasing or decreasing. Processing can be started only under the premise that Z-axis is monotonic; besides, there can be 20 grooves at most.

As shown in Fig. 4-5-2-1, the first cutting needn't be perpendicular and processing can be started only under the premise that Z-axis is monotonic.

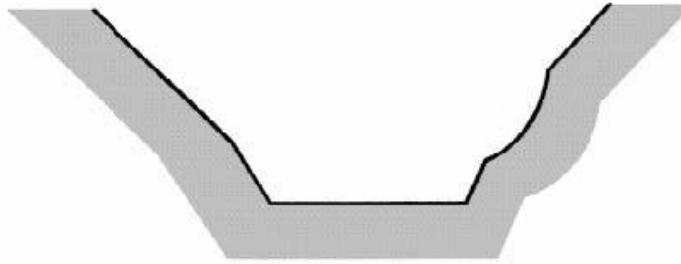

Fig. 4-5-2-1

As shown in Fig. 4-5-2-2, the system will give alarm, because it is not monotonic in Z-axis direction.

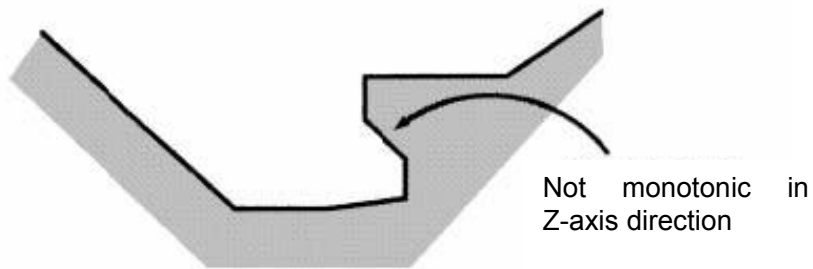

Fig. 4-5-2-2

Format: G71 U(Δd)R(e);

G71 P(NS) Q(NF) U(Δu) W(Δw)F S T;

N(NS) G0/G1 X(U) Z(W).;

.....;

.... F;

.... S;

.... T;

.

N(NF).;

} Program segment of find processing route

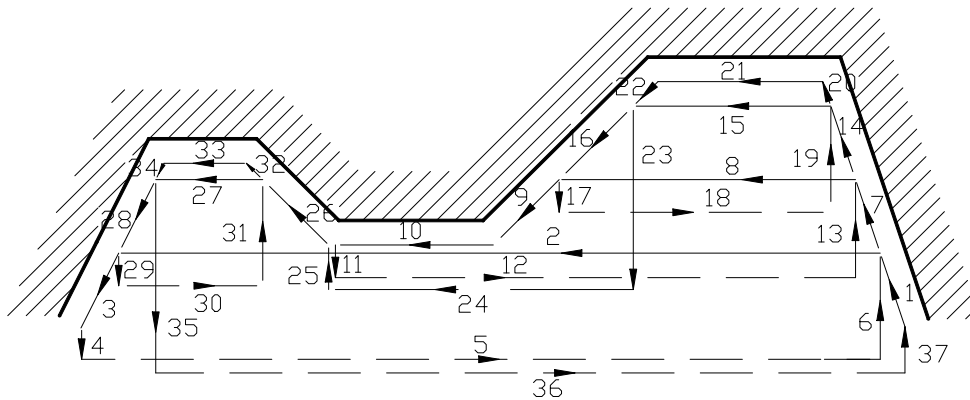

Fig. 4-5-2-3(Processing Path of Type II of G71)

As shown in Fig. 4-5-2-4, it is required to retract tool after cutting; retreat amount should be specified by the parameter R(e) or by the data parameter No. 464. Diagram concerned is as follows:

● Set by parameter

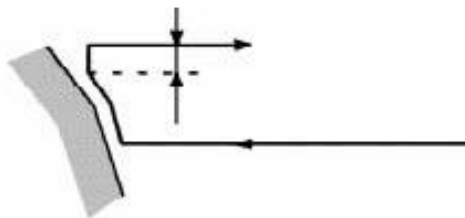

Fig. 4-5-2-4

Precautions:

1. ns program segment is G00 and G01 codes. For Type II, it is required to specify the two axes X(U) and Z(W); W0 must be specified when Z-axis has no movement.
2. Retract point should be high or low as much as possible, for fear that treat tool has impact on workpice.
3. For Type II, fine turning allowance can only specify X direction. The whole processing path will have offset if fine turning allowance in Z direction is specified; 0 had better be set as if so.
4. Other precautions are the same with those of Type I of G71.
5. In P0461 compound turning circulation, there will be alarm if non-monotonic allowable values of G71 and G72 (Axis 1 in the plane) and rough turning direction of Type I and Type II are not monotonic. Under automatic program building and other circumstances, there may form a tiny non-monotonic shape sometimes. The parameter should be set without negative sign and serve as allowable value, so that G71 and G72 instructions can be executed even though non-monotonic shape is included.
6. In P0460 compound turning circulation, there will be alarm if non-monotonic allowable values of G71 and G72 (Axis Z in the plane) and rough turning direction of Type I and Type II are not monotonic. Under automatic program building and other circumstances, there may form a tiny non-monotonic shape sometimes. The parameter should be set without negative sign and serve as allowable value, so that G71 and G72 instructions can be executed even though non-monotonic shape is included.
7. Idle stroke amount of starting position for G71 and G72 cutting feed in P0477 compound turning fixed circulation rapidly moves to cutting feed distance among tool advancement points.

4.5.3 Radial rough turning circulation (Type I of G72)

Format: G72 W(Δd)R (e)F_ S_ T_;

G72 P(NS) Q(NF) U(Δu) W(Δw);

N(NS)G0/G1 Z(W) . . . ;

.....;

.... F;

.... S;

.... T;

N(NF).;

} Program segment for fine processing

Function: The system will calculate rough machining route automatically according to workpiece fine processing route, depth of cut and tool advancement mount and retreat mount given by NS-NF program segment. Non-molded bars can be shaped at a time.

Instructions:

Δd : Depth of cut for each time, without symbol. Cutting direction depends on AB direction, with value scope for 0.001 mm-99,999.999mm. It is a modal mode and will be valid until next specifying. In addition, it can also be specified by the data parameter P463, and parameter value can be changed according to program instruction.

e: Retreat amount (radius specifying), with unit for mm and value for 0 mm-99,999.999 mm. It is a modal code and will be valid until next specifying. It can also be set by the data parameter P464, and parameter value can be changed in case of using program instruction.

NS: Sequence number of the first program segment for fine processing route program segment cluster.

NF: Sequence number of the last program segment for fine processing route program segment cluster.

Δu : Distance and direction of fine processing allowance in X-axis direction, with value scope for -999,999.99-999,999.99mm.

Δw : Distance and direction of fine processing allowance in Z-axis direction, with value scope for -999,999.99-999,999.99mm.

F: Cutting feed speed, with value scope for 1mm/min-6,000mm/min for feed per minute and 0.001mm/r-500mm/r for feed per revolution.

S: Speed of main axis;

T: Tool and tool offset number;

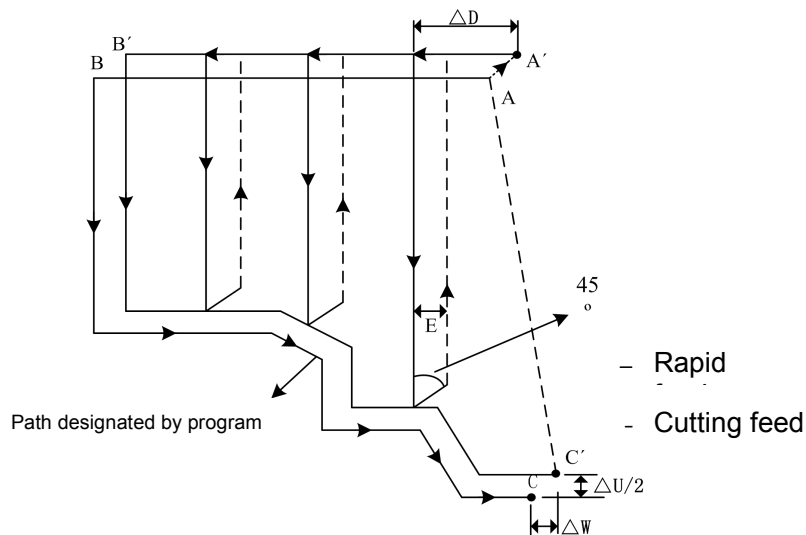

Fig. 4-5-3-1

Instructions:

1. Both Δd and Δu are specified by the same address U; the distinguishing method is whether to specified P or Q according to program segment.
2. Circulation action is specified by G72 code specified by P and Q.
3. In G72 circulation, F, S and T functions in program segment of the sequence numbers NS-NF are invalid and should be ignored. G72 program segment or F, S and T specified previously are valid. In program segments of sequence numbers NS-NF, F, S and T are only open to G70 code circulation.
4. Where there is constant line speed control selection function, G96 or G97 in program segment of the sequence numbers NS-NF is invalid and those specified by G71 or pervious program segment are valid.
5. G72 code path has four types according to different cutting directions, as shown in Fig. 4-5-3-2. But cutting is performed according to tool movement parallel to Z-axis no matter which kind of type it is. Δu and Δw symbols are shown in Fig. 4-5-3-2.
6. In NS program segment of the sequence number A-B, it is only allowed to use G00 or G01 for specifying and Z-axes of A point and B point should be consistent.
7. In B-C, X and Z address values must be of monotonic increasing or decreasing.
8. In program segment of the sequence numbers NS-NF, it is not allowed to invoke subprogram.
9. In the sequence numbers NS-NF, 128 program segments can be entered at most; the system will give alarm ERR137 when number of program segments is beyond 100.

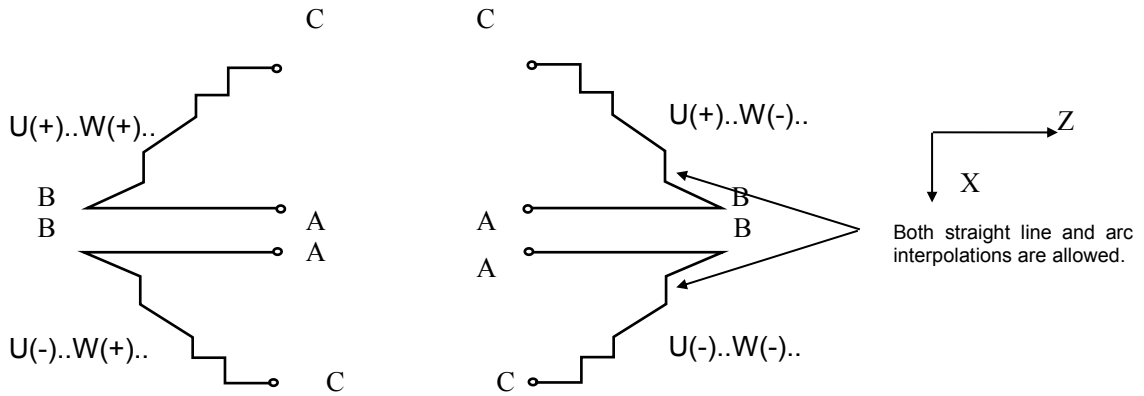

Fig. 4-5-3-2 Four Types of G72 Code

For example, write component program in Fig. 4-5-3-3 through compound fixed circulation G72.

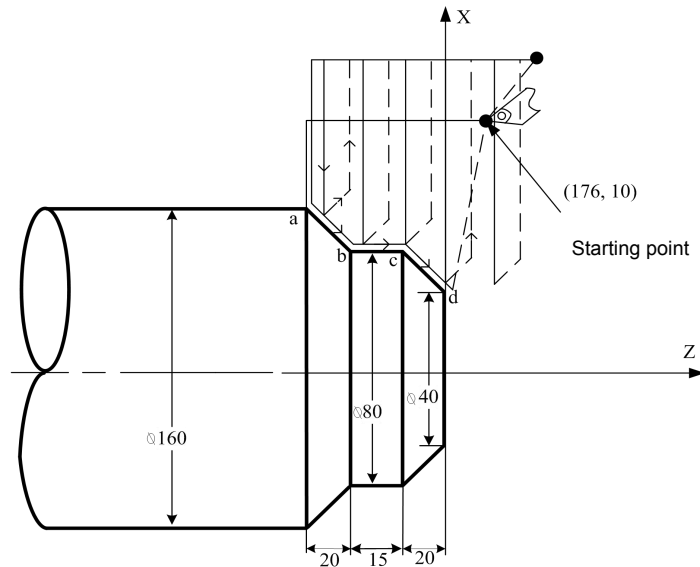

Fig. 4-5-3-3

Program:

```

PO0002;
N010 G0 X220.0 Z50.0; (position to safety position)
N015 T0202;           (Change No. 2 tool and execute tool offset)
N017 M03 S200;       (anticlockwise rotation of main axis, with speed for 200)
N020 G00 X176.0 Z10.0; (rapid positioning and approaching workpiece)
N030 G72 W2.0 R1.0; (feed amount: 2mm; retract amount: 1mm)
N040 G72 P050 Q090 U1.0 W1.0 F100 S200; (for a—d rough turning, there should be 1mm
margin respectively on X-axis and Z-axis)
N050 G00 Z-55.0 S200; (rapid positioning)
N060 G01 X160.0 F120; (feed to a point)
N070 X80.0 W20.0;     (a—b processing)
N080 W15.0;          (b—c processing)
N090 X40.0 W20.0;     (c—d processing)
N100 G0 X220.0 Z50.0; (retract tool to safety position)
    
```

} Program segment for fine processing route

- N105 T0303; (change No. 3 tool and execute No. 3 tool offset)
- N108 G00 X176.0 Z10.0; (return to G70 location rapidly)
- N110 G70 P050 Q090; (a—d fine processing)
- N115 G0 X220.0 Z50.0; (move to safety position, for convenience of tool replacement)
- N120 M5 S0 T0200; (stop main axis, change No. 2 tool and cancel tool offset)
- N130 G0 X220.0 Z50.0; (return to starting point rapidly)
- N140 M30; (program ends)

4.5.4 Groove circulation processing (Type II of G72)

Type II is different from Type I, and the details are as follows:

- 1) Related definition: For Type II, number of parameters is 1 more than that of Type I.
- 2) Monotonic increasing or decreasing is unnecessary for appearance outline along X-axis; besides there should be 10 grooves at most. Diagram concerned is as follows:



Fig. 4-5-4-1

However, surface outline along X-axis must be of monotonic increasing or decreasing; outline below cannot be processed:

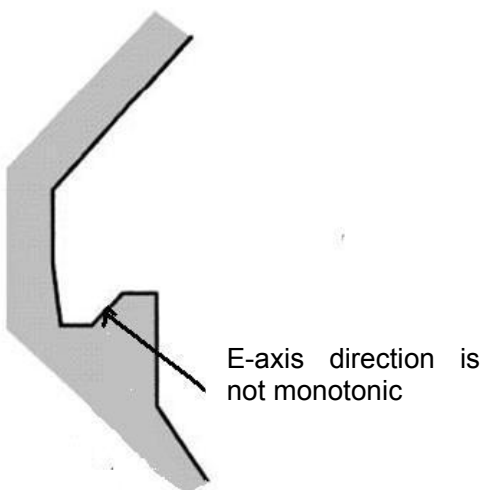

Fig. 4-5-4-2

- 1) The first cutting needn't be perpendicular and processing can be started only under the premise that Z-axis is monotonic; diagram concerned is as follows:

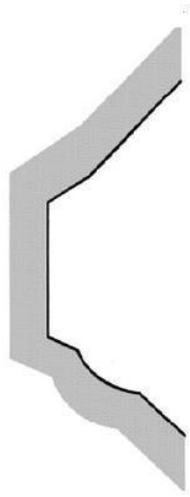

Fig. 4-5-4-3

2) It is required to retract tool after cutting and retract amount is specified by the parameter R (e) or by setting value of data parameter No. 464; diagram concerned is as follows:

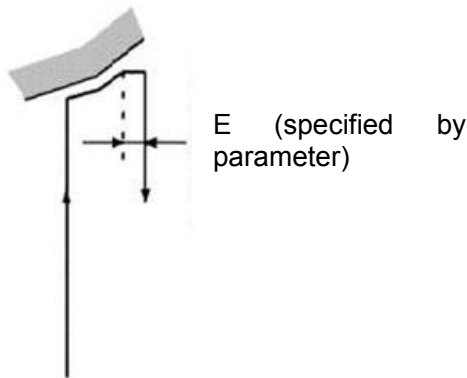

Fig. 4-5-4-4

3) Fine turning allowance can only specify Z direction. The whole processing path will have offset if fine turning allowance in X direction is specified; 0 had better be set as if so.

Format: G72 W(Δd) R (e) F_ S_ T_;

G72 P(NS) Q(NF) U(Δu) W(Δw);

N(NS) G0/G1 X(U) Z(W) . . . ;

.....;

.... F;

.... S;

.... T;

N(NF);

} Program segment for fine processing

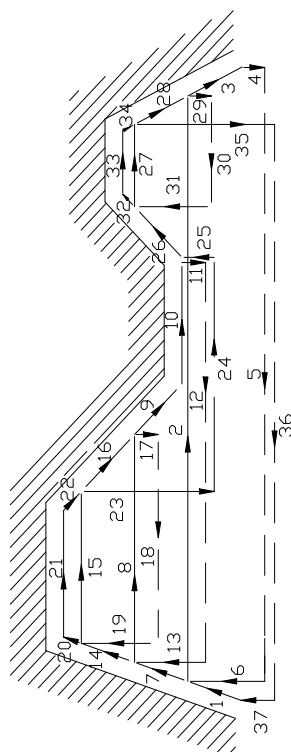

Fig. 4-5-4-5(G72 Processing Path)

4.5.5 Closed cutting circulation (G73)

Format: G73u (Δi) W(Δk) R (d);

G73 P(NS) Q(NF) U(Δu) W(Δw) F S T ;

Function: With this circulation code, repeated cutting can be implemented as per path given by NS-NF program segment; for every cutting, tool will move forward once. Workblank preliminarily formed through forging, casting and other rough machining methods can be processed efficiently.

Instructions: Retract distance and direction in X-axis direction (radius value), with unit for mm; it is a modal code and will be valid until next specifying. In addition, it can also be specified by the data parameter P465 and parameter value can be changed according to program instruction.

Δk : Retract distance and direction in Z-axis direction, with unit for mm; it is a modal code and will be valid until next specifying. In addition, it can also be specified by the data parameter P466 and parameter value can be changed according to program instruction.

D: Times of closed cutting, with unit for time; it is a modal code and will be valid until next specifying. In addition, it can be set by the parameter P467 and parameter value can be changed according to program instruction.

NS: Sequence number of the first program segment for fine processing shape program segment cluster;

NF: Sequence number of the last program segment for fine processing shape program segment cluster;

Δu : Fine processing allowance in X-axis direction, with value scope for

-999,999.99-999,999.99mm;

Δw : Fine processing allowance in Z-axis direction, with value scope for -999,999.99-999,999.99mm;

F: Cutting feed speed, with value scope form 1 mm/min-6,000mm/min.

S: Speed of main axis;

T: Tool and tool offset number;

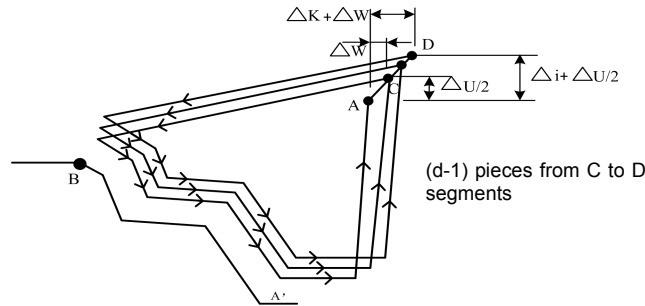

Fig. 4-5-5-1 G73 Code Operation Path

1. In NS-NF, F and S functions in any program segment are invalid; F and S functions specified in G73 are valid.

2. Δi , Δk , Δu and Δw are specified by the addresses U and W; the difference method is whether to specified P or Q.

3. In A-B, it is only allowed to use G00 or G01 for specifying in program segment of the sequence number NS.

4. In G73, NS-NF program segment cannot invoke subprogram.

5. Circulation processing is implemented according to NS-NF program segment; upon programming, please pay attention to symbols of Δu , Δw , Δi and Δk . After circulation, tool will return to A point.

6. If any one of Δi and Δk in the program is 0, it is required to write down U0 or W0 in the program or set the data parameters as P466 and P467. If not, it may be affected by setting value of the last G73 program.

7. There should be 100 program segment s at most in the sequence numbers NS-NF; the system will give alarm ERR0460 when number of program segments is beyond 100.

For example, write component processing program in the Fig. 4-5-5-2 through the cutting circulation code G73

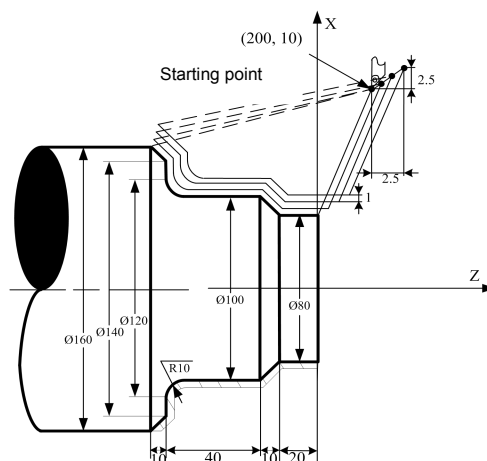

Fig. 4-5-5-2 Diagram of G73Code Example

Program: (diameter specified; metric input; the minimum workblank is Ø86)

```

N008 G0 X260.0 Z50.0;          (rapidly position to safety position)
N009 T0101;                    (change No. 1 tool and execute No. 1 tool offset)
N010 G98 M03 S300;             (positive rotation of main axis, with speed for 300)
N011 G00 X200.0 Z10.0;        (rapidly position to starting point)
N012 G73 U2.0 W2.0 R3;        (retract tool by 4 mm towards X direction; retract tool by 2 mm
towards Z direction)
N013 G73 P014 Q020 U0.5 W0.5 F100;( reserve fine turning allowance respectively on
X-axis and Z-axis)
N014 G00 X80.0 W-10.0 S500;
N015 G01 W-20.0 F120;
N016 X100.0 W-10.0;
N017 W-30.0;
N018 G02 X120 W-10.0 R10.0 F100;
N019 G01 X140.0;
N020 G01 X160.0 W-10.0;
N021 G0 X260.0 Z50.0; (move to safety position, for convenience of tool replacement)
N022 T0303;                (change No. 3 tool and execute No. 3 tool offset)
N023 G00 X200.0 Z10.0; (return to G70 location rapidly)
N024 G70 P014 Q020; (fine processing)
N025 M5 S0 T0200;         (stop main axis, change No. 2 tool and cancel tool offset)
N026 G0 X260.0 Z50.0; (return to starting point rapidly)
N027 M30;                 (program ends)
    
```

} Program segment for fine processing shape

4.5.6 Fine processing circulation (G70)

Format: G70 P(NS) Q(NF);

Function: Upon executing this instruction, tool will be provided with fine processing along workpiece fine processing path given by NS-NF program segment from starting position.

G70 code can be used for fine turning after rough machining for G71, G72 and G73.

Instructions: NS: Sequence number of the first program segment for fine processing shape program segment cluster.

NF: Sequence number of the last program segment for fine processing shape program segment cluster.

G70 code path depends on programming path of NS~NF program segment. Relative

position relationship of NS and NF in G70-G73 program segment is as follows:

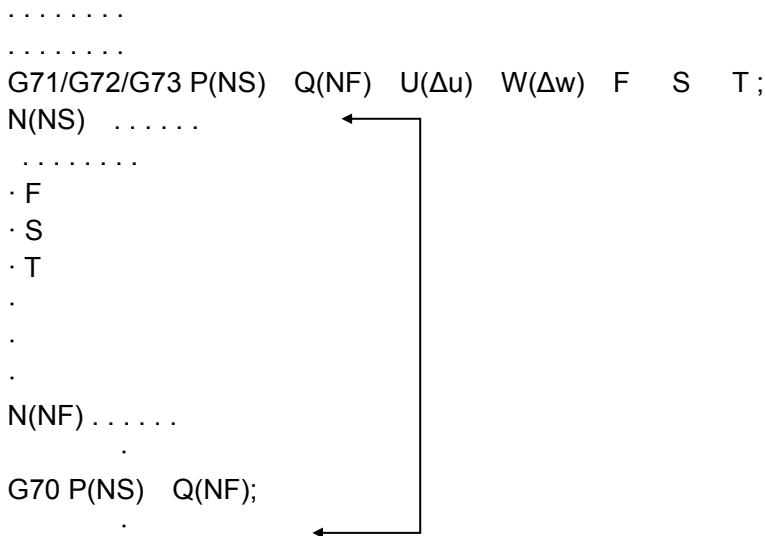

1. In G71, G72 and G73, F, S and T functions specified by NS-NF program segment are invalid; but upon executing G70, F, S and T specified by the sequence numbers NS-NF are valid.
2. Tool will return to starting point and the next program will be read when G70 circulation processing ends.
3. NS-NF program segment in G70 cannot invoke subprogram.

For details, please see examples of the codes G71 and G72.

4.5.7 Axial grooving circulation (G74)

Format: G74 R(e);

G74 X(U) Z(W) P(Δi) Q(Δk) R(Δd) F;

Function: Upon executing this code, the system will decide tool movement path according to cutting end point determined by the program segment (point determined by X-axis and Z-axis coordinate values in program segment) and e, Δi , Δk and Δd values. In this circulation, appearance cutting breaking can be treated; additionally, it will be deep hold drilling circulation if X(U) and P are omitted and only Z-axis acts. The path is shown in Fig. 4-5-7-1.

Instructions: e: Retract amount after Δk cutting along Z direction for each time, with value scope for 0-99,999.999 mm; it is a modal code and will be valid until next specifying. In addition, the data parameter P468 can also be set and parameter value can be changed according to instruction.

X: Absolute coordinate value of cutting end point B2 in X direction, with unit for mm;

U: Total movement amount of cutting end point B2 and cutting starting point A in X direction, with unit for mm;

Z: Total movement amount of cutting end point B2 in Z direction of, with unit for mm;

W: Total movement amount of cutting end point B2 and starting A in Z direction, with unit for mm;

Δi : Movement amount for every circulation in X direction (without symbol and radius value), with unit for mm;

Δk : Movement amount for every cutting in Z direction (without symbol), with unit for mm;

Δd : Retract amount for cutting arriving at end point in X direction (radius value), with unit for mm;

F: Cutting feed speed, with value scope 1mm/min-8000mm/min for feed per minute and 0.001mm/r-500mm/r for feed per revolution.

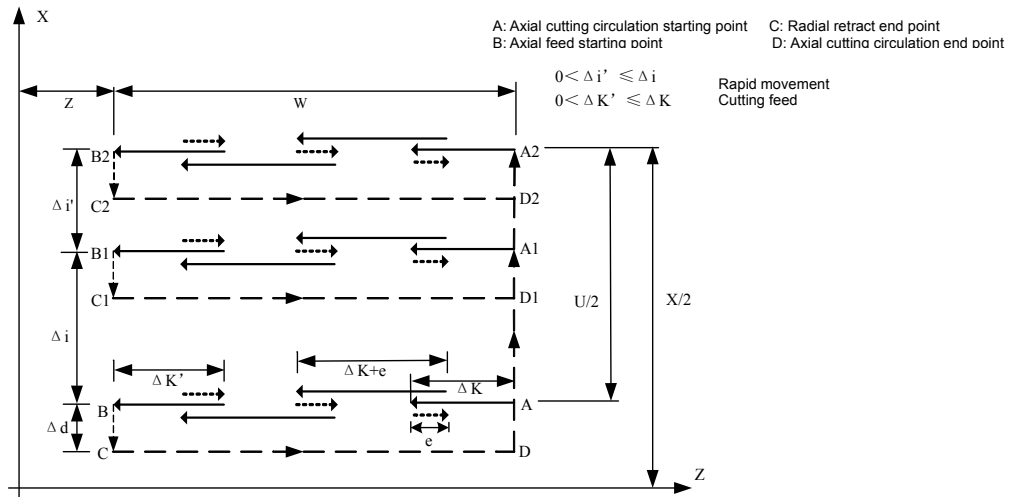

Fig. 4-5-7-1

1. Both e and Δd are specified by the address R; the difference is whether to specify Z(W) or not. That is to say, it will be Δd if X(U) is specified; it will be e if Z(W) is specified;
 2. Circulation is performed in G74 program segment including Z(W) and $Q(\Delta k)$. Circulation will not be implemented if only G74 R(e) program segment is executed.
- For example, write component program in Fig. 4-5-7-2 through G74 code.

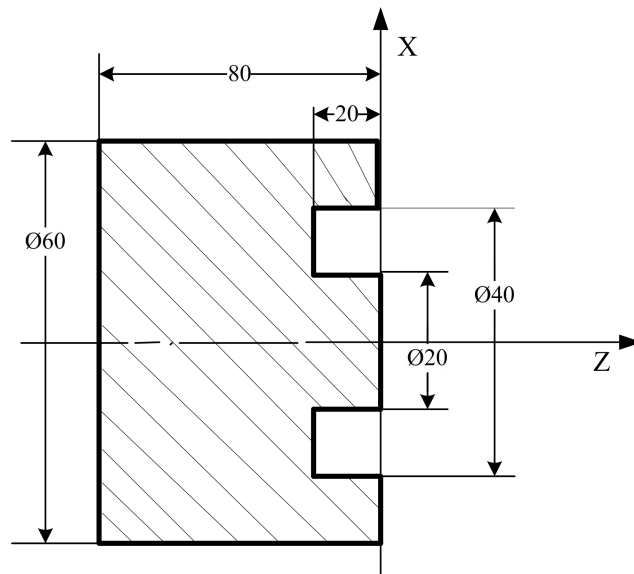

Fig. 4-5-7-2

```

Program:
O0001;          (program name)
G0 X100 Z50;   (rapid positioning)
T0101;         (tool width: 2mm)
M3 S500 G97;   (start main axis and set speed as 500)
G0 X36 Z5;     (position to processing starting point; X-axis has been added to tool
width)
G74 R1;        (instruct retract amount of Z direction)
G74 X20 Z-20 P2 Q3.5 F50; (movement amount of X-axis for every circulation: 4mm;
movement amount of Z-axis for every circulation: 3.5mm)
    
```

G0 Z50; (Z direction retract)
 X100; (X direction retract)
 M5 S0; (stop main axis)
 M30; (program ends)

4.5.8 Radial grooving circulation (G75)

Format: G75 R(e);

G75 X(U) Z(W) P(Δi) Q(Δk) R(Δd) F ;

Function: Upon executing this code, the system will decide tool movement path according to cutting end point determined by the program segment (point determined by X-axis and Z-axis coordinate values in program segment) and e, Δi , Δk and Δd values. It is similar to exchange X and Z in G74. In this circulation, end face cutting breaking can be treated and outer diameter can be grooved and cut (Z, W and Q omission). Path is shown in Fig. 4-5-8-1.

Instructions: e: Retract amount after Δk cutting along Z direction for each time, with value scope for 0-99,999.999 mm; it is a modal code and will be valid until next specifying. In addition, the data parameter P468 can also be set and parameter value can be changed according to instruction.

X: Absolute coordinate value of cutting end point B2 in X direction, with unit for mm;

U: Total movement amount of cutting end point B2 and cutting starting point A in X direction, with unit for mm;

Z: Total movement amount of cutting end point B2 in Z direction of, with unit for mm;

W: Total movement amount of cutting end point B2 and starting A in Z direction, with unit for mm;

Δi : Movement amount for every circulation in X direction (without symbol and radius value), with unit for mm;

Δk : Movement amount for every cutting in Z direction (without symbol), with unit for mm;

Δd : Retract amount for cutting arriving at end point in Z direction, with unit for mm;

F: Cutting feed speed

Both G7 and G75 can be used in cutting, grooving or hole processing; tool can be used for automatic retract.

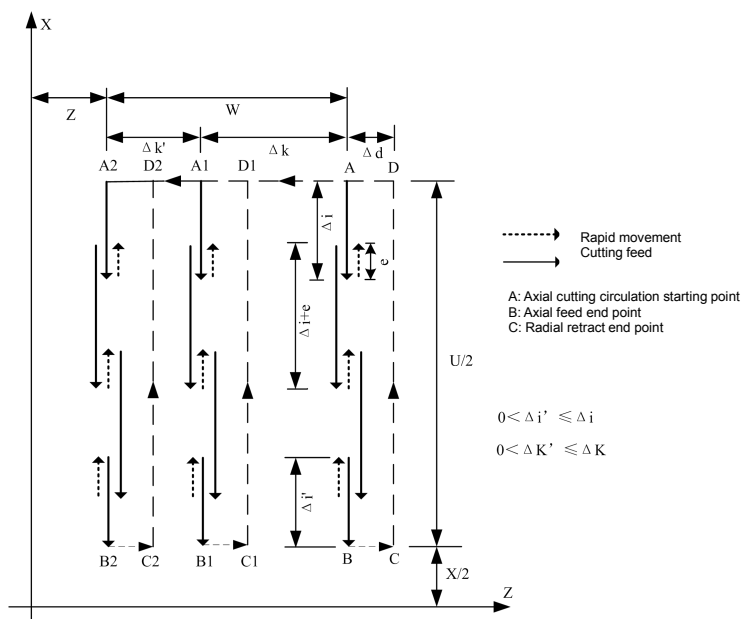

Fig. 4-5-8-1

- Both e and Δd are specified by the address R; the difference is whether to specify X(U). That is to say, it will be Δd if X(U) is specified; it will be e if X(U) is not specified;
- Circulation is performed in specified G75 code including X(U).

For example, write component program in Fig. 4-5-8-2 through G75 code.

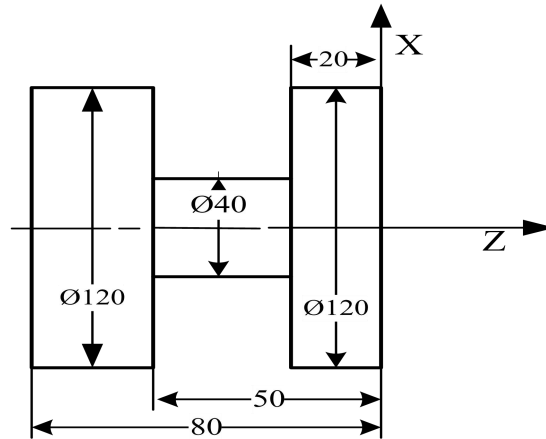

Fig. 4-5-8-2 Diagram of G75Code Cutting Example

Program:

```

O0001;          (program name)
G0 X150 Z50;    (rapid positioning)
T0101;          (tool width: 4 mm)
M3 S500 G97;    (start main axis and set speed as 500)
G0 X125 Z-24;   (position to processing starting point; Z-axis has been added to tool
width)
G75 R1;         (instruct retract amount of Z direction)
G75 X40 Z-50 P2 Q3.5 F50;( movement amount of X-axis for every circulation: 4mm;
movement amount of Z-axis for every circulation: 3.5mm)
G0 X150;        (X direction retract)
Z50;           (Z direction retract)
M5 S0;         (stop main axis)
M30;           (program ends)
    
```

4.5.9 Multiple thread cycles (G76)

Code format: G76 P (m) (r) (a) Q (Δd_{min}) R (d);

G76 X (U) Z (W) R (i) P (k) Q (Δd) F (l);

G76 X (U) Z (W) R (i) P (k) Q (Δd) F (l);

Function: the system can have automatic calculation and implement multiple thread cutting circulations and thread processing according to the data of instruction address. Code path is as shown in Fig. 4-5-9-1.

Note: X, Z: Absolute value for thread end point (thread bottom); unit: mm;
 U, W: Total travel of processing start point relative to thread end point; unit: mm;
 m: Repeat time of final fine processing 1~99; this code is modal and effective before the next setting. Besides, data parameter **P471** is also settable; parameter can be changed according to program instruction. The range for repeat times of final fine processing is 1~99;
 r: Chamfering amount of thread. If L is used as lead, it should use 0.1L as one gear within

scope of 0.1L~9.9L and it can be assigned by 2-digit figure of 00~99. This code is modal and effective before the next setting. Besides, data parameter **P473** is also settable; parameter can be changed according to program instruction. The chamfering amount of thread set in Program G76 is also effective in thread cutting circulation of G92.

a: Angle of tool nose (optional angle of thread tooth includes 80°, 60°, 55°, 30°, 29° and 0°)

The original value of this angle can be assigned by 2-digit figure. This code is modal and effective before the next setting. Besides, data parameter **P472** is also settable; parameter can be changed according to program instruction. Optional angle of tool nose includes 80°, 60°, 55°, 30°, 29° and 0°

Δd_{min} : Min. approach; unit: mm. If primary approach ($\Delta D \times \sqrt{N} - \Delta D \times \sqrt{N-1}$) is lower than Δd_{min} , choose Δd_{min} as primary approach. This code is modal and effective before the next setting. Besides, data parameter P469 is also settable; parameter can be changed according to program instruction. Setting range for the min. approach is 0~9999.9999; unit: 0.001mm;

d: Margin of fine processing; unit: mm. This code is modal and effective before the next setting. Besides, data parameter **P471** is also settable; parameter can be changed according to program instruction. Setting range for margin of fine processing is 0~9999.999; unit: 0.001mm;

i: Radius difference of thread; unit: mm; i=0 means cutting of straight thread;

k: Height of thread (Radius should be used as distance at X-axis direction); unit: mm;

Δd : The 1st cutting depth, radius; unit: mm.

F: Thread lead; unit: mm.

I: Threads per inch.

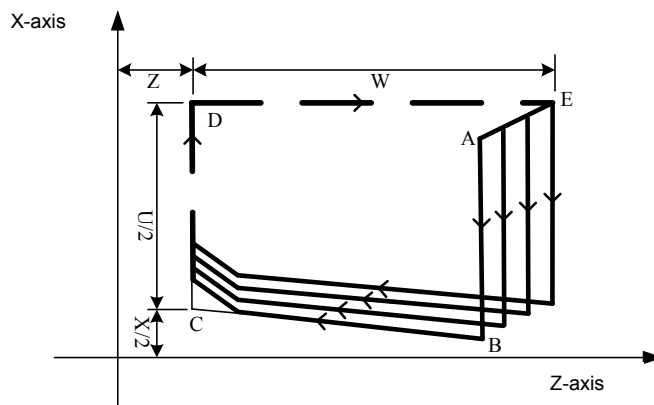

Fig. 4-5-9-1

For details about approach, please see **Fig. 4-5-9-2** below:

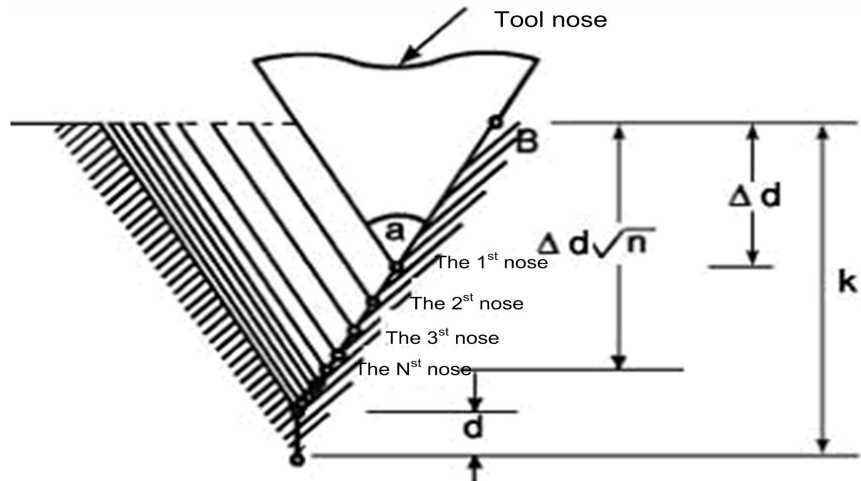

Fig. 4-5-9-2

1. Distinction should be made using data assigned by P, Q and R and whether there's address X (U) and Z (W).
2. Circulation action should be implemented by Code G76 assigned by Address X (U), Z (W).
3. Load on tool nose should be reduced if single-side blade is used for processing in circular processing.
4. The approach should be Δd in the first time or $\Delta D \times \sqrt{N}$ in the time N; the amount of each cutting is fixed.
5. Four processing graphics are available, or internal threads can be processed giving consideration to the symbol of each address. Feed speed of Instruction F is used only between B and C in thread cutting shown in Fig. 4-5-8-1; while rapid feed is used by others. In circulation, the increment symbol should be determined by the following methods:
 - U: determined by Path A to the Direction C;
 - W: determined by Path C to the Direction D;
 - R (I): determined by Path A to the Direction C;
 - P (K): positive;
 - Q (ΔD): positive
6. Notice for thread cutting is the same with G32 thread cutting.
7. Assigned chamfering amount of thread is also effective to G92 thread cutting cycle.
8. Address p should be used for designating m, r and a.

For example, thread cutting compound cycle Code G76 is used for programming the program shown in Fig. 4-5-9-3; processing thread is M68×6.

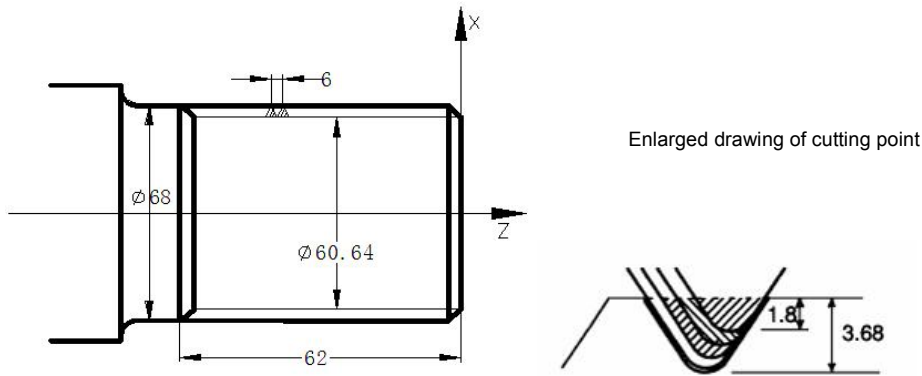

Fig. 4-5-9-3

Program is as follows:

G00 X100 Z50;	(Positioned to safe position)
M03 S300;	(Start spindle, designate revolving speed)
G00 X80 Z10;	(Quickly positioned to processing start point)
G76 P011060 Q0.1 R0.2;	(Implement thread cutting)
G76 X60.64 Z-62 P3.68 Q1.8 F6.0;	
G00 X100 Z50;	(Returning to program start point)
M5 S0;	(Stop spindle)
M30;	(Program completed)

4.5.10 Notice for compound and fixed loop code

1. Necessary parameters, such as P, Q, X, Z, U, W and R, should be assigned in the program segment of compound and fixed circulation. Instructions in each program segment must be correct.
2. If sequence number is assigned by P in program segment of Code G71, G72 and G73, G00 or G01 in Code G of Group 01 must be assigned by program segment which corresponds to this sequence number; otherwise, the system will give out P/S alarm.
3. It is not allowed to execute Code G70, G71, G72, G73, G74, G75 and G76 in MDI mode, even if they are assigned.
4. Program segment G70, G71, G72 and G73, of which sequence number is assigned by P and Q, should be free from the following instructions:
 - ★ Codes of Group 01 except for Code G00, G01, G02 and G03;
 - ★ M98/M99;
 - ★ Code G04, which is effective in the final forming cutting in rough processing and in fine processing
5. The executed compound fixed circulation (G70~G76) can be stopped to insert manual operation.

6. While Code G70, G71, G72 and G73 is being executed, the sequence number assigned P and Q should have no coincidence in this program.
7. Notice for assigned G76 thread cutting is the same with G32 thread cutting and G92 thread cutting circulation; the assigned chamfering amount of thread is also effective to G92 thread cutting circulation.

4.6 Tool Compensation Function

The actual tool nose should be regarded as an arc instead of point. The error between actual result and workpiece program, which is caused by tool nose arc, can be eliminated by tool radius compensation of tool compensation function.

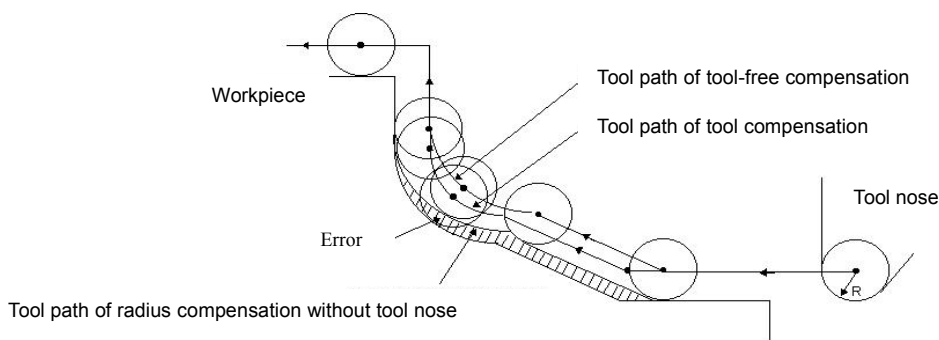

Fig. 4-6-1

4.6.1 Basic concept for tool compensation function C

4.6.1.1 Concept of assumed tool nose

Tool nose Point A in Fig. 4-6-1-1-1 below doesn't exist and so it is called assumed tool nose (or ideal tool nose). The tool nose is assumed since it is difficult to set radius center of tool nose at start position, but easy to set assumed tool nose at start position, as shown in figure below. The same with tool nose center, it is not needed to consider radius of tool nose if implementing programming using assumed tool nose.

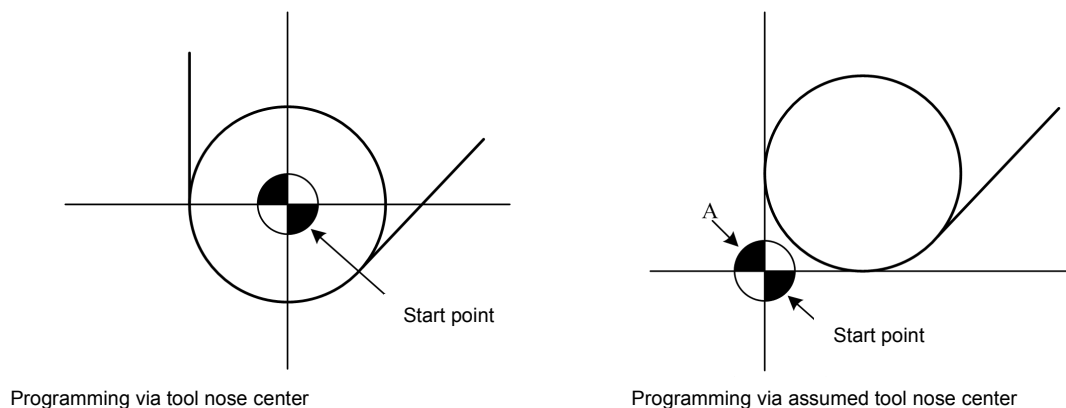

Fig. 4-6-1-1-1 Tool Nose Radius Center and Assumed Tool Nose

Note: A standard point, such as tool rest center, can be used as start point for machine tool which has zero point. The distance from this standard point to tool nose radius center or assumed tool nose should be set as tool offset value. The distance from standard point to tool nose radius center should be set as offset value, as if

setting tool radius center as start point; the distance from standard point to tool nose should be set as offset value, as if setting assumed tool nose as start point. To set offset value of tool, it can be easier to measure the distance from standard point to assumed tool nose than distance from standard point to tool nose radius center; therefore, the distance from standard point to assumed tool nose is generally used for setting tool offset value.

If tool nose center is used as start point, tool offset value is as shown in Fig. 4-6-1-1-2:

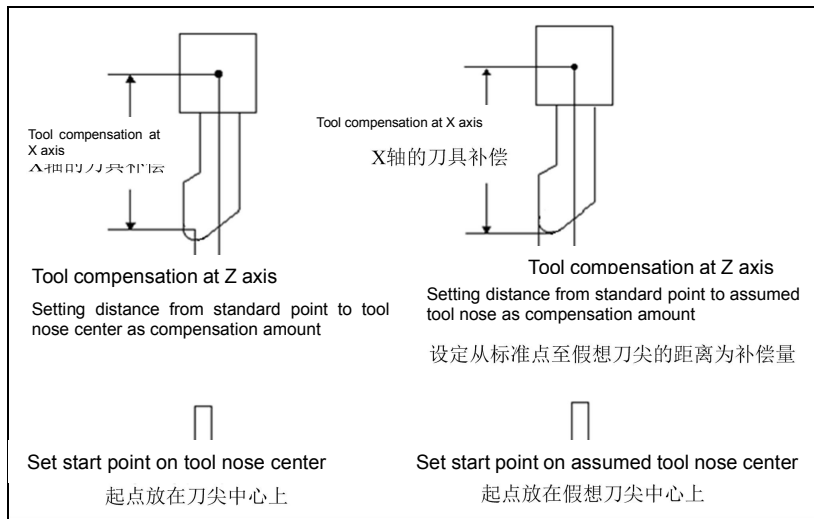

Fig. 4-6-1-1-2 Setting of Tool Offset Value if Taking Tool Center as Standard Point

Tool path programmed using tool nose center and assumed tool nose is respectively shown in Fig. 4-6-1-1-3 and 4-6-1-1-4. The left and right figure respectively shows the offset value with and without tool nose radius compensation.

If tool nose radius compensation is used, the tool nose center path will realize precise cutting and be the same with programming path.

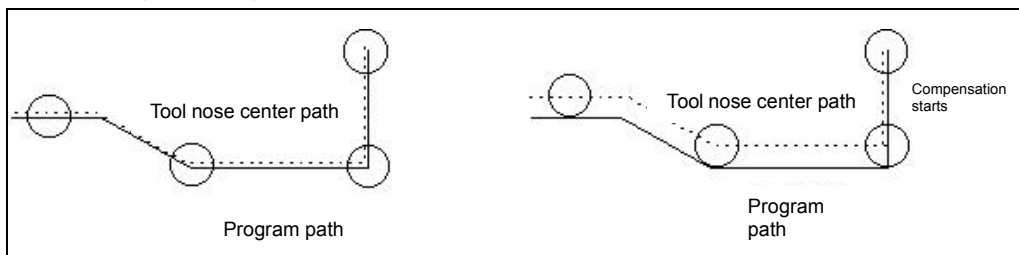

Fig. 4-6-1-1-3 Tool Path if Programming via Tool Nose Center

If tool head radius compensation is used, tool nose path will realize precise cutting and be the same with programming path.

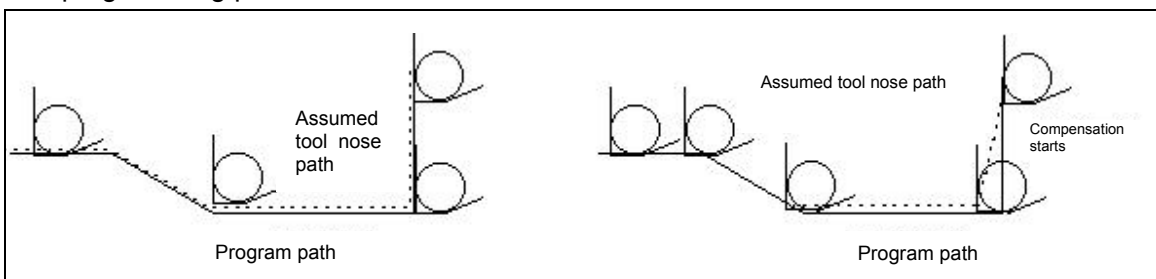

Fig. 4-6-1-1-4 Tool Path if Programming via Assumed Tool Nose

4.6.1.2 Direction of assumed tool nose

The tool and workpiece may stay at different positions in actual processing as needed by the processing of workpiece. The direction of assumed tool nose observed from tool nose center should be determined by the direction of cutting tool.

Position relationship between assumed tool nose and tool nose arc center is defined by assumed tool nose number. The assumed tool nose number contains a total of 10 (0~9) settings to represent the position relationship of 9 directions. Assumed tool nose number must be, before implementation of tool nose radius compensation, inputted to tool nose radius compensation together with compensation amount. The direction of assumed tool nose can be selected according to number of eight specifications shown in figures below. In these figures, relationship between tool and start point is introduced, and assumed tool nose is taken as arrow end point.

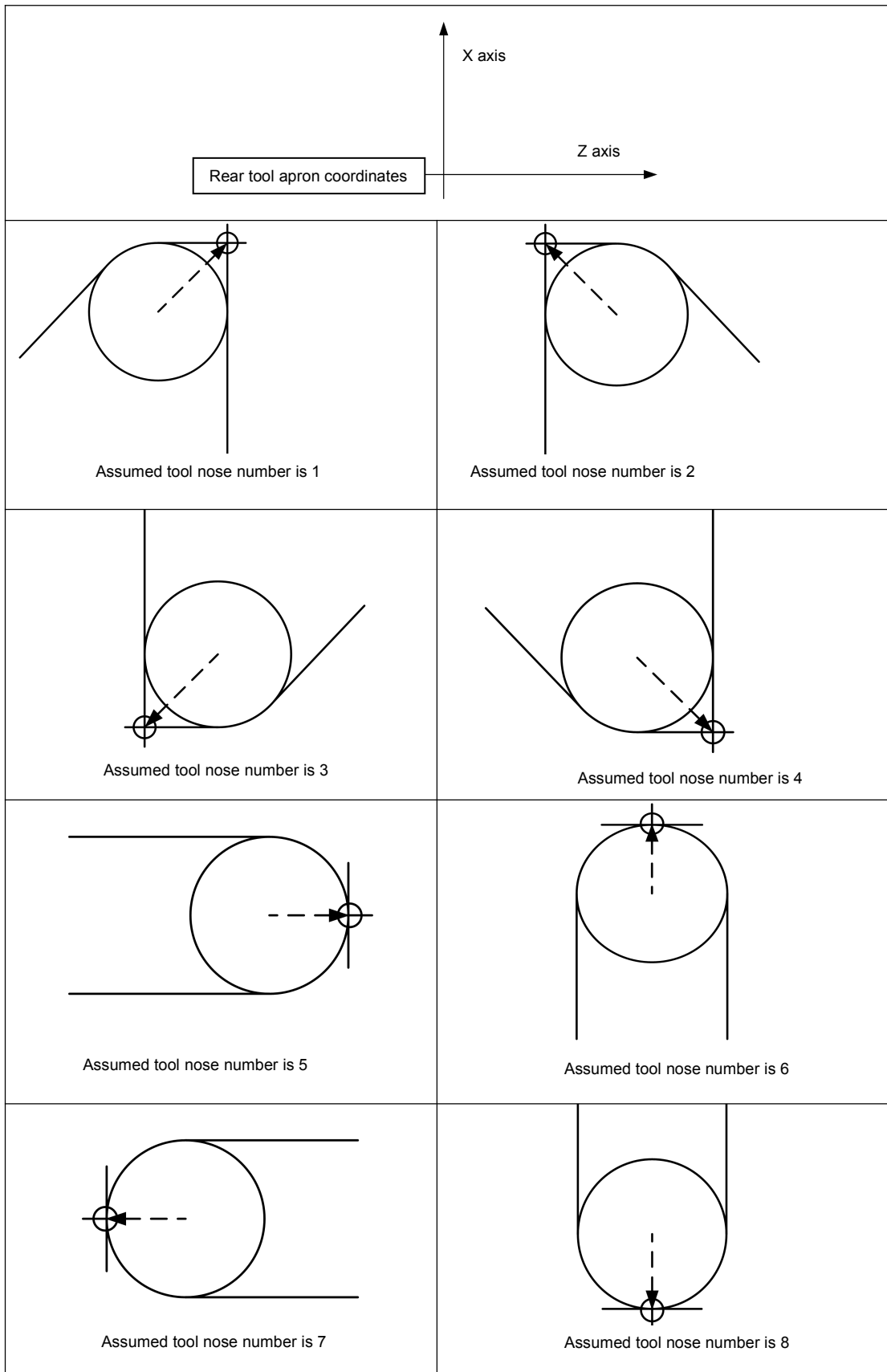

Fig. 4-6-1-2-1 Assumed Tool Nose Number in Rear Tool Apron Coordinates

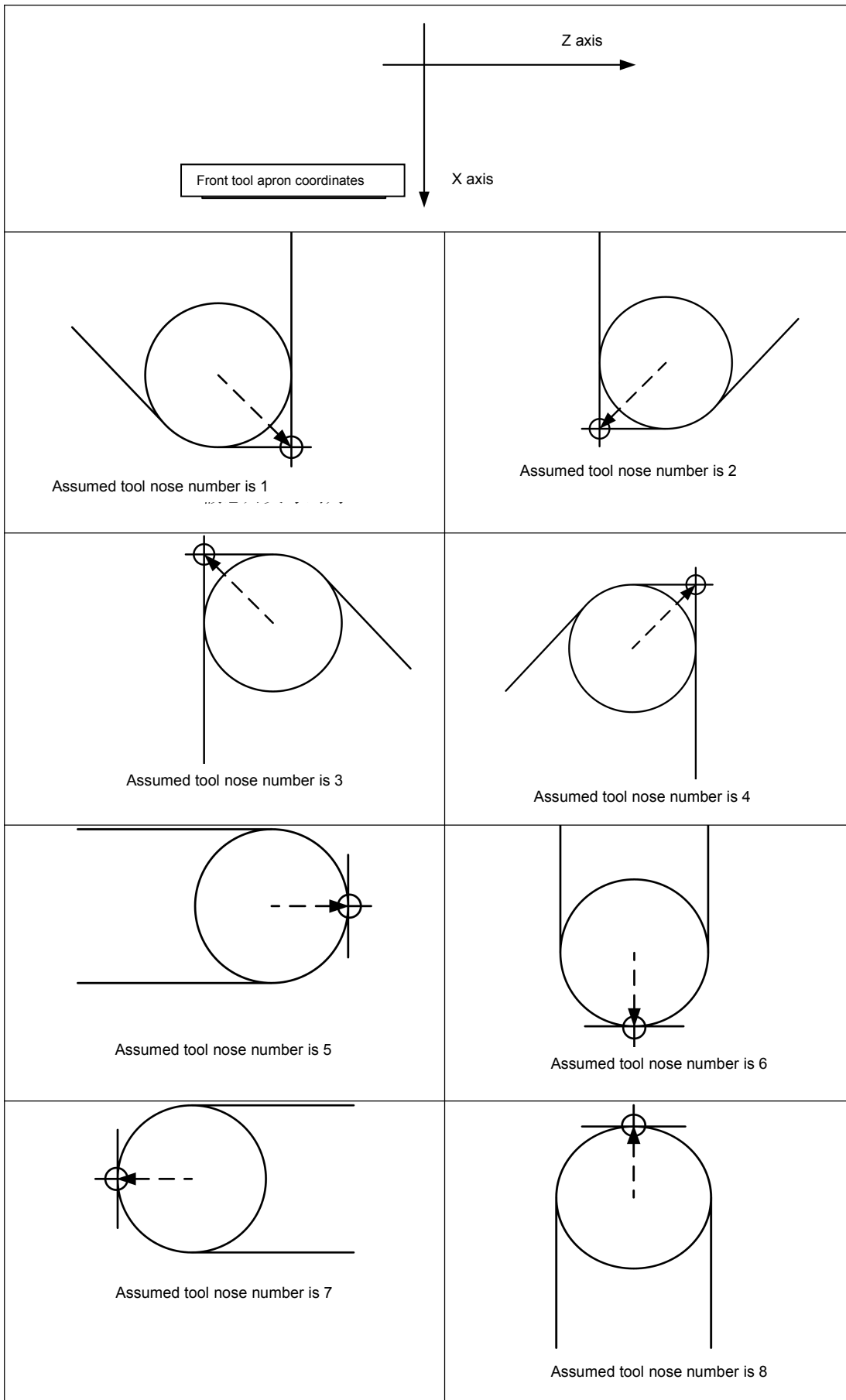

Fig. 4-6-1-2-2 Assumed Tool Nose Number in Front Tool Apron Coordinates

If tool nose center is consistent with start point, tool nose number should be set as 0 or 9. It is needed to set assumed tool nose number of all tools using Address T according to corresponding tool compensation number.

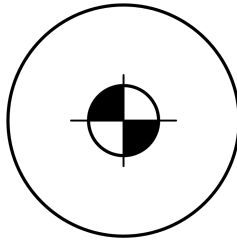
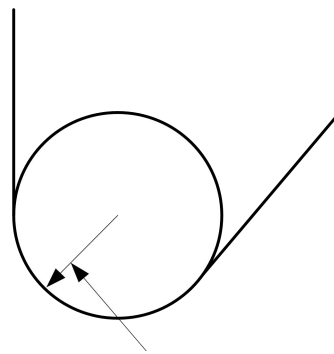

Fig. 4-6-1-2-3 Tool Nose is Consistent with Start Point

4.6.1.3 Setting of compensation value



Tool nose radius compensation value

Fig. 4-6-1-3-1 Tool Nose Radius Compensation Value

It is needed to, before setting tool nose radius compensation, set the following compensation values: X, Z, R and T; in which, X and Z refer to the tool offset value from tool rest center to tool center at direction of Axis X and Z respectively; R refers to the radius compensation value of assumed tool nose; T refers to assumed tool nose number. Each group of values corresponds to one tool compensation value and they should be set in tool compensation interface. For details, please refer to *Revision and Setting of Tool Compensation Value*.

Details are shown in Table 4-6-1-3-1 below:

Table 4-6-1-3-1 Display Page for Tool Nose Radius Compensation Value of System

S/N	X	Z	R	T
001	0.020	0.030	0.020	2
002	0.060	0.060	0.016	3
..
..
..
015	0.030	0.026	0.18	9
064	0.050	0.038	0.20	1

4.6.1.4 Relative position of tool and workpiece

Relative position between tool and workpiece must be assigned before implementing tool nose radius compensation. In rear tool apron coordinate system, it is called right tool compensation if tool center path stays at the right side of programming path (part path) and it should be realized by Code G42; or it is called left compensation if tool center path stays at the left side of programming path (part path) and it should be realized by Code G41; it is contrary to the front door apron. If Code G40, G41 and G42 are assigned, the detailed introduction to relative position of tool and workpiece is shown in Table 4-6-1-4-1:

Table 4-6-1-4-1

Instru ction	Introduction	Remarks
G40	Cancel tool nose radius compensation	For details, please see Fig. 4-6-1-4-1 and Fig. 4-6-1-4-2
G41	Left compensation to tool nose radius in rear tool apron coordination system; right compensation of tool nose radius in front tool apron coordination system;	
G42	Right compensation to tool nose radius in rear tool apron coordination system; left compensation of tool nose radius in front tool apron coordination system;	

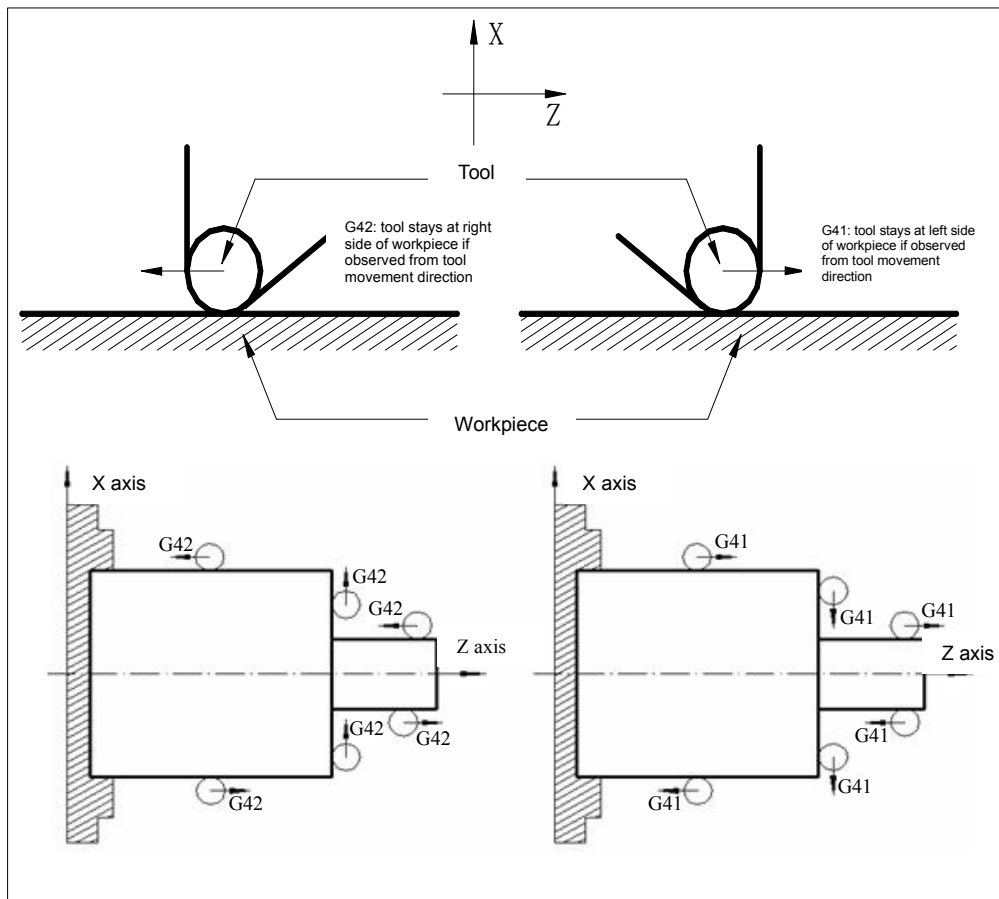

Fig. 4-6-1-4-1 Tool Nose Radius Compensation in Rear Tool Apron Coordination System

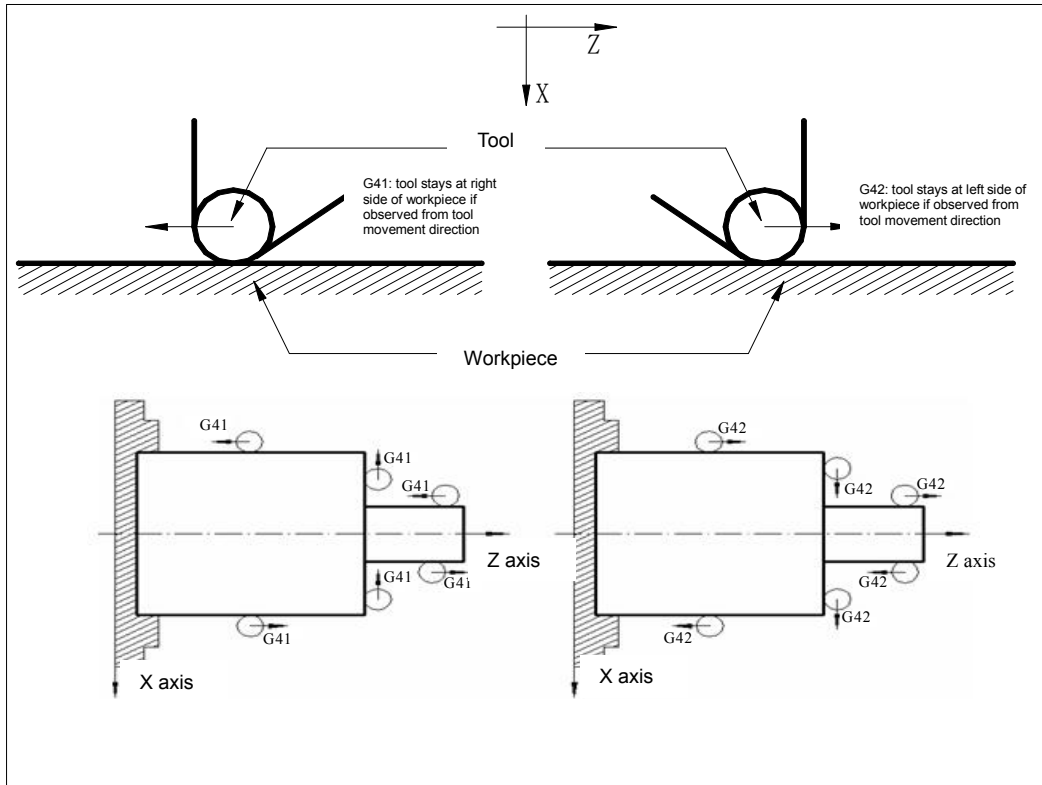

Fig. 4-6-1-4-2 Tool Nose Radius Compensation in Front Tool Apron Coordination System

4.6.1.5 Inner and outer side

If front and rear programming paths have different turning corners in tool nose radius compensation, the tool nose compensation path will become different. Therefore, it is called “Inner side” if included angle of intersection point between two moving program segments stays at workpiece is equal to or larger than 180° , or called “Outer side” if angle is $0^\circ \sim 180^\circ$.

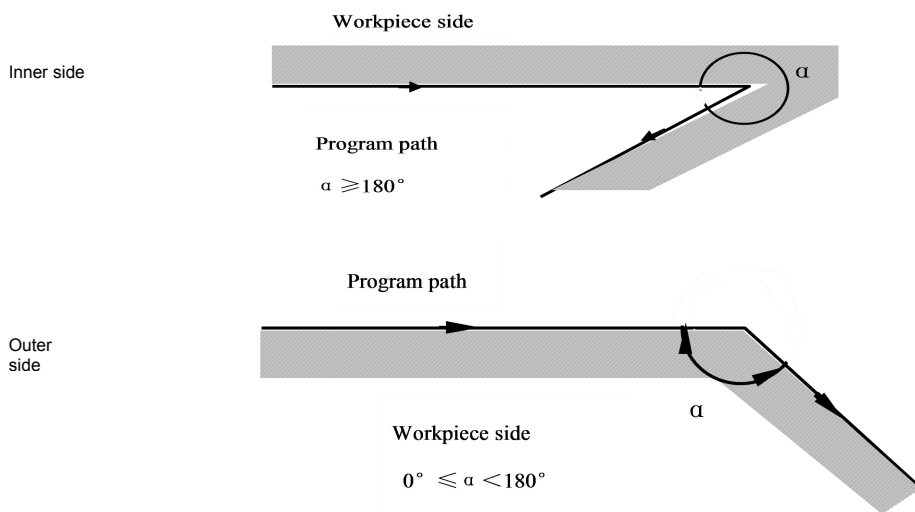
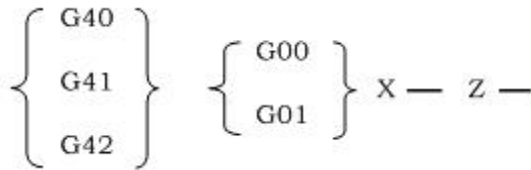

Fig. 4-6-1-5-1 Inner Side and Outer Side

4.6.1.6 Code format of G41, G42 and G40

Code format:



Note 1: G40, G41 and G42 are modal Code G.

Note 2: if tool compensation is established normally, G41/G42 can be followed by Code G02 or G03.

4.6.2 Details of tool compensation

4.6.2.1 Decomposition to detailed path of tool nose radius compensation

Generally, tool radius compensation is realized by 3 steps: tool compensation establishment, tool compensation implementation and tool compensation cancellation.

1. Tool compensation establishment

It is called tool compensation establishment if offset cancelation mode is switched to offset mode.

Detailed tool compensation establishment is shown in Fig. 4-6-2-1-1 below:

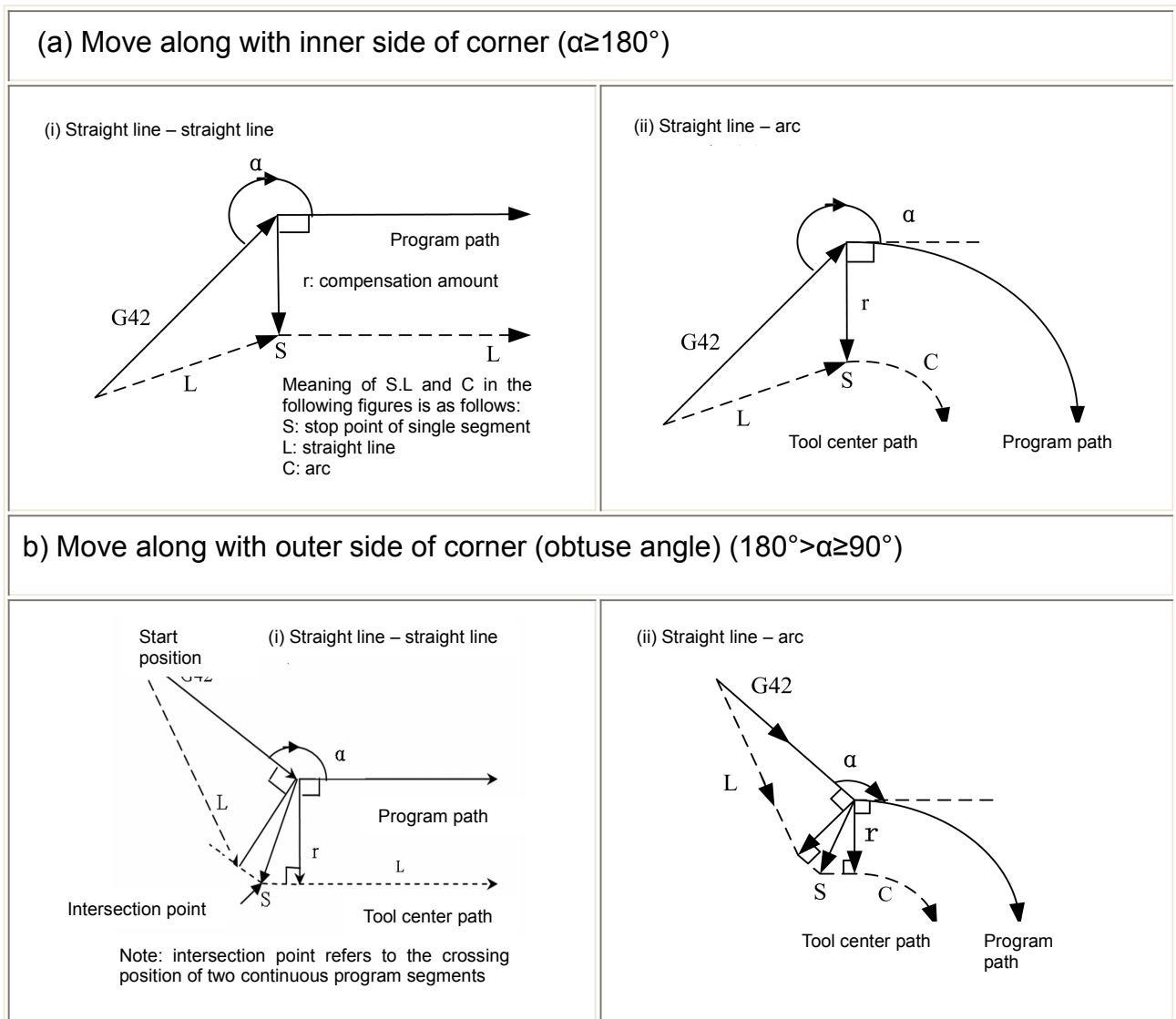

(c) Move along with outer side of corner (acute angle) ($\alpha < 90^\circ$)

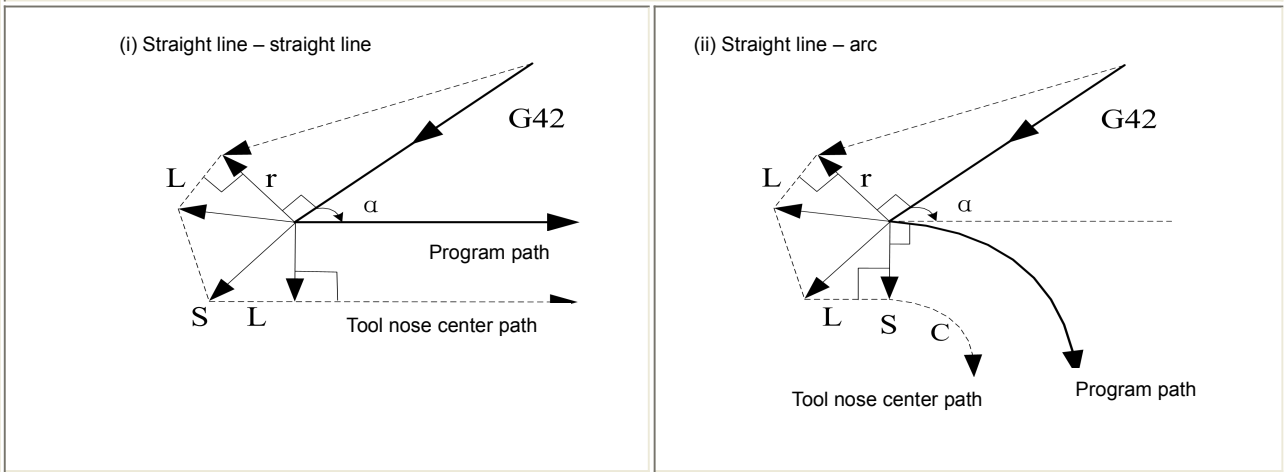

(d) Move along with outer side of corner (acute angle less than 1°); straight line \rightarrow straight line. ($\alpha < 1^\circ$)

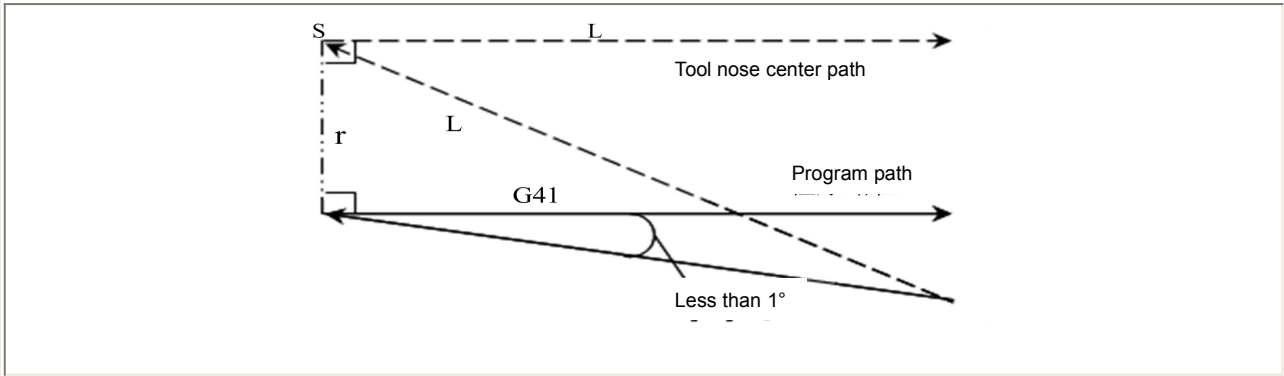

Fig. 4-6-2-1-1 Tool Compensation Establishment

Note 1: If no tool compensation number is assigned, or tool compensation number is zero when tool compensation is establishment, program will give out alarm #036.

Note 2: It is needed to have execution through movement instruction G0 or G1 when tool compensation is established; if instruction is arc, program will give out alarm #034.

2. Tool compensation implementation

The offset path from tool establishment to tool compensation cancellation is called tool compensation implementation.

Detailed tool compensation is shown in Fig. 4-6-2-1-2 and 4-6-2-1-3 below:

(a) Move along with inner side of corner ($\alpha \geq 180^\circ$)

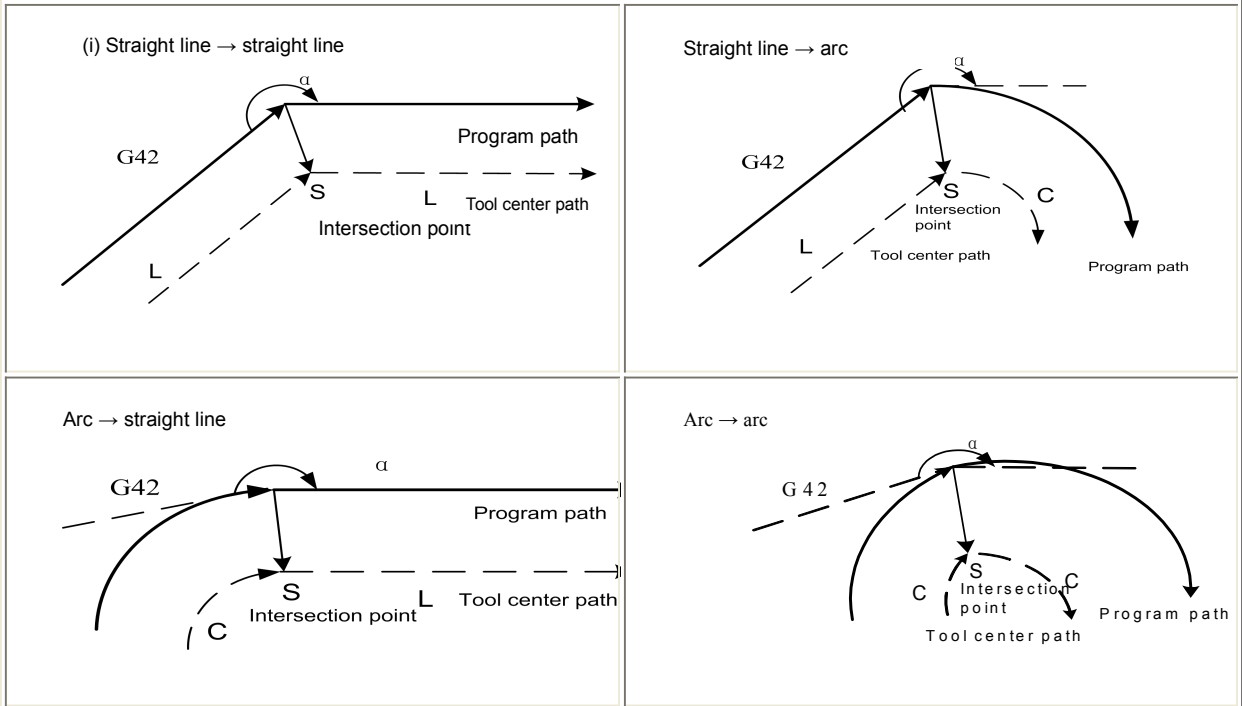

(V) Inner side processing and enlarged compensation amount for angle $< 1^\circ$

(i) Straight line → straight line

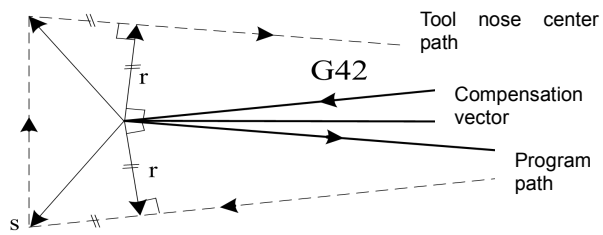

The following cases should be considered using the same method:
 (ii) Arc → Straight line
 (iii) Straight line → Arc
 (iv) Arc → Arc

(b) Move along with exterior side of corner (obtuse angle) ($180^\circ > \alpha \geq 90^\circ$)

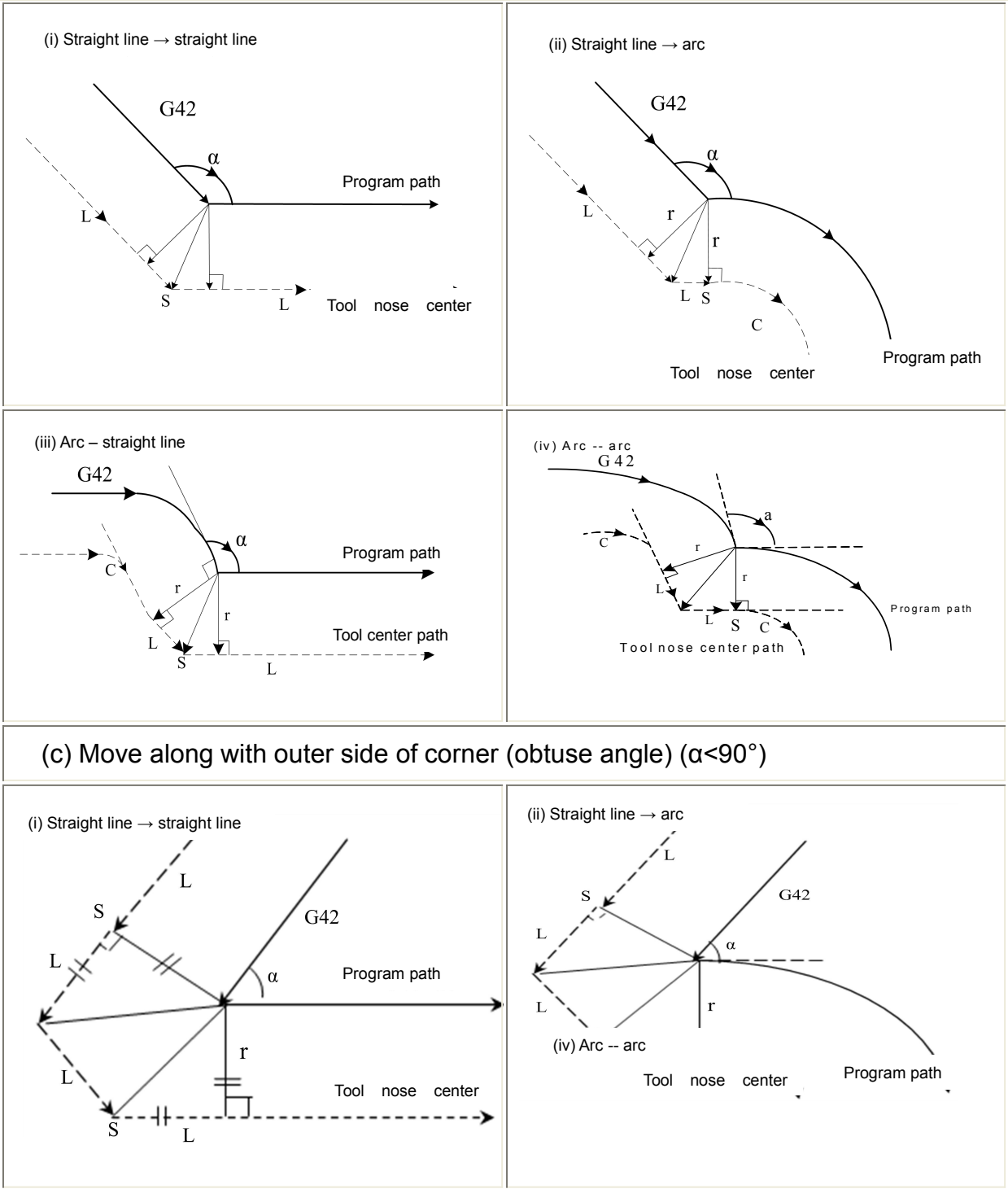

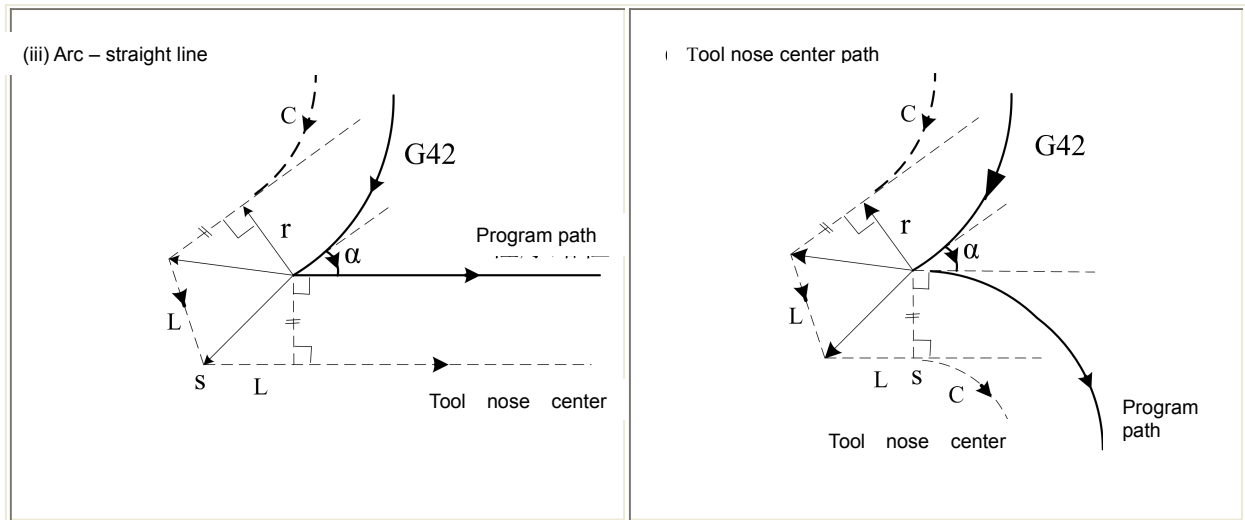

Fig. 4-6-2-1-2 Tool Compensation Implementation

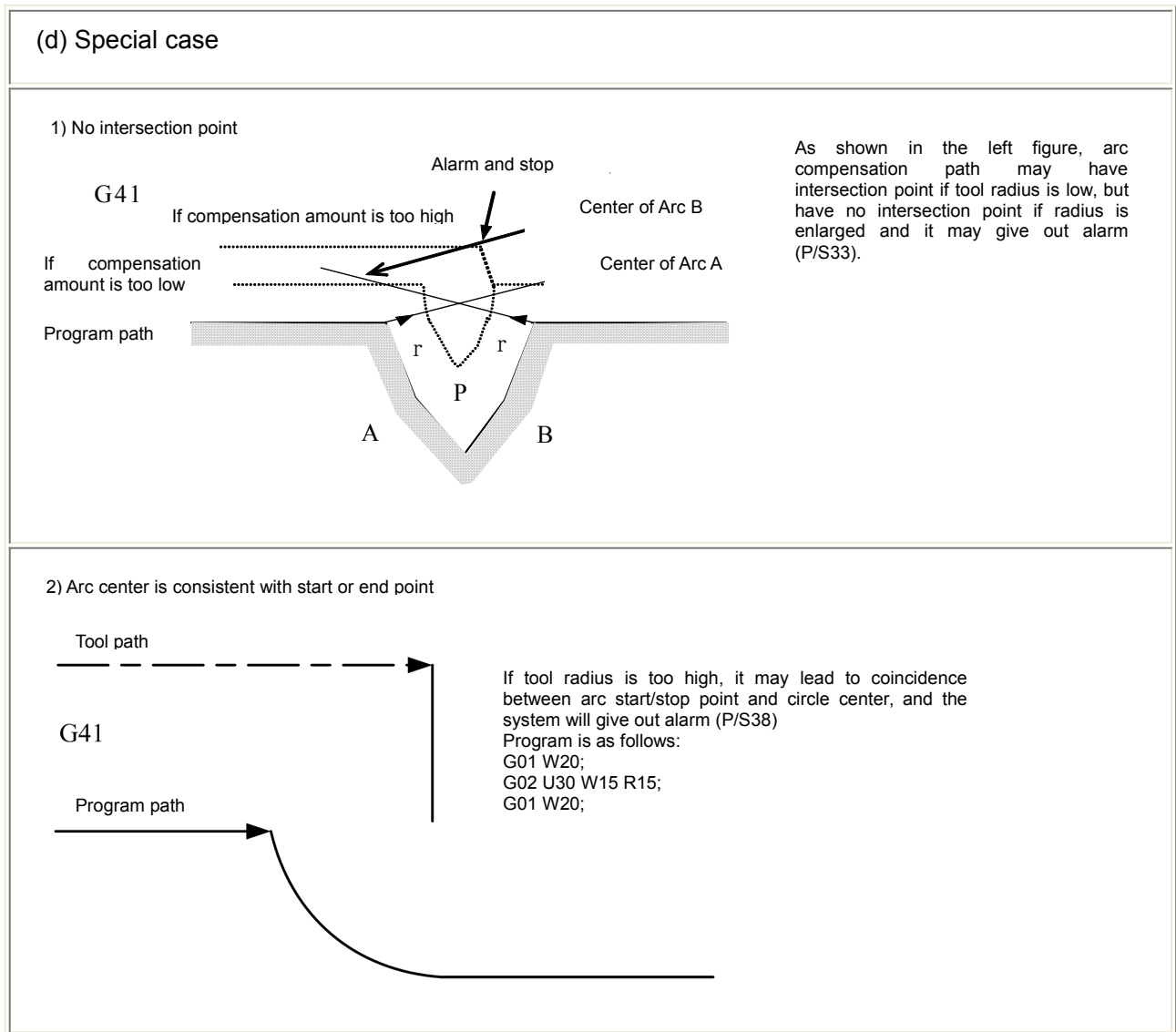

Fig. 4-6-2-1-3 Tool Compensation Implementation ②

3. Tool Compensation Cancellation

If any of the following condition is satisfied by program in compensation mode, the system will enter

compensation cancellation mode, and the action in this program segment is called tool compensation cancellation.

(a) Tool compensation is cancelled using Code G40; it is not allowed to use arc code (G02 and G03) while executing tool compensation cancellation. If arc is assigned, it will give out alarm (N0.34) and stop tool.

(b) Tool radius compensation number is assigned as 0.

Details about tool compensation cancellation are as shown in figures below:

(a) Move along with inner side of corner ($\alpha \geq 180^\circ$)

(i) Straight line → straight line

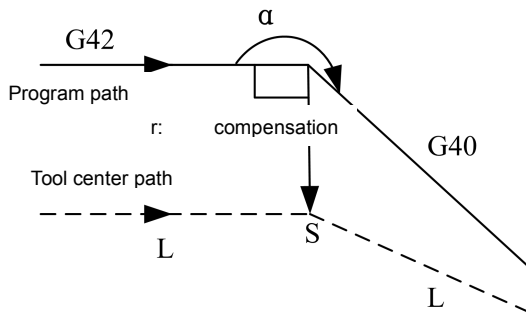

(i) Arc → straight line

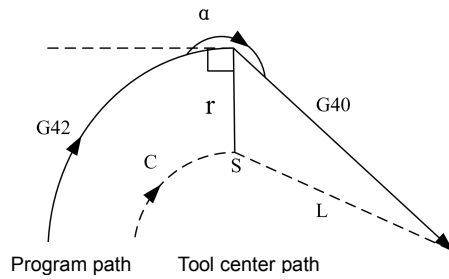

(b) Move along with outer side of corner (obtuse angle) ($180^\circ > \alpha \geq 90^\circ$)

(i) Straight line → straight line

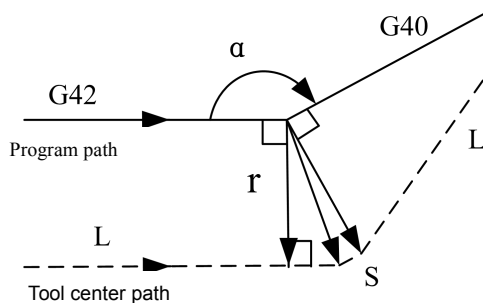

(i) Arc → straight line

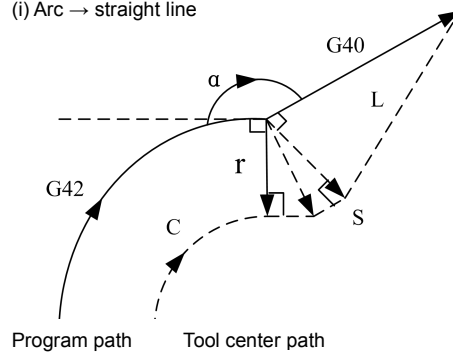

(c) Move along with outer side of corner (acute angle) ($\alpha < 90^\circ$)

(i) Straight line → straight line

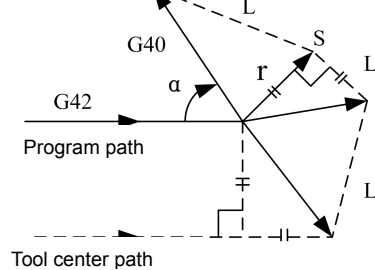

(i) Arc → straight line

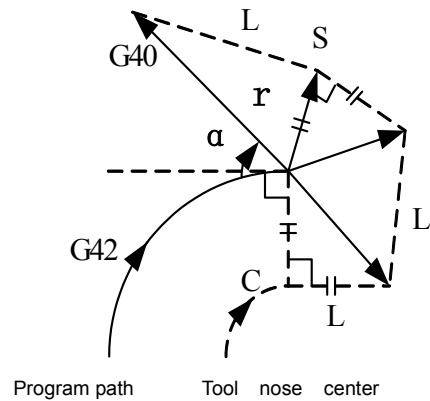

(d) Move along with outer side of corner (acute angle less than 1°); straight line \rightarrow straight line ($\alpha < 1^\circ$)

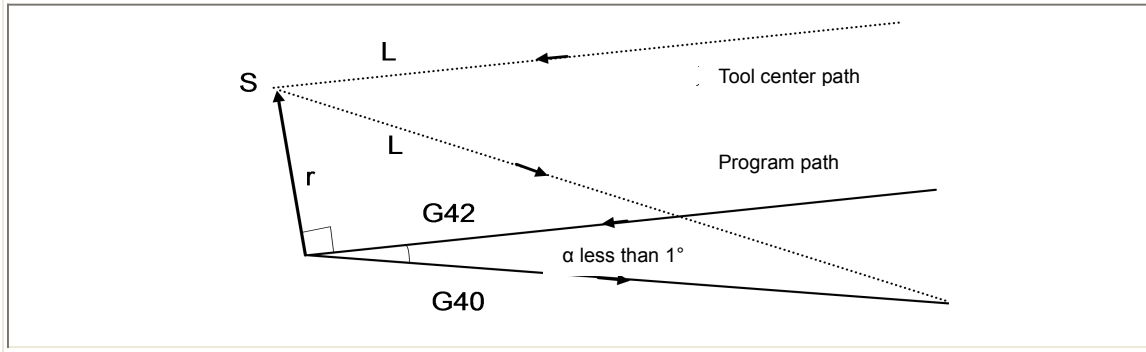

Fig. 4-6-2-1-4 Tool Compensation Cancellation

4.6.2.2 Change tool compensation direction in tool compensation implementation

Compensation direction is determined by tool radius compensation Code G (G41 and G42). The symbol of compensation amount is as follows:

Table 4-6-2-2-1

Compensation Amount Symbol Code G	+	-
	G41	Left compensation
G42	Right compensation	Left compensation

Compensation direction is changeable in compensation mode of special cases, but unchangeable at initial program segment. There's no distinction for inner and outer side in all conditions while compensation direction is changed. The following compensation amounts are assumed to be positive.

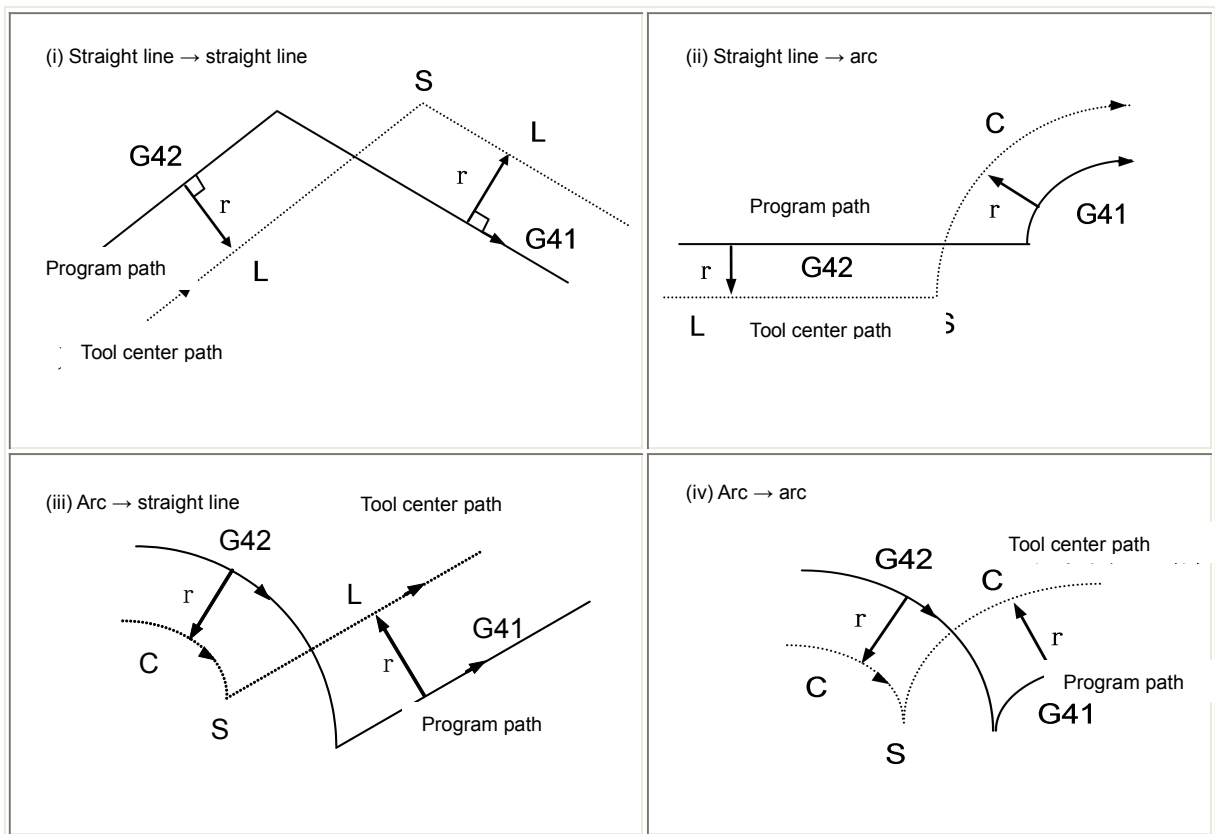

Fig. 4-6-2-2-1 Compensation Direction Change in Tool Compensation Implementation

If there's no intersection point and offset direction from Program Segment A to B is changed by Code G41 and G42 during normal implementation of compensation, the start point in Program Segment B should be prepared into vector which is vertical to Program Segment B if there's no need for offset of path intersection.

i) Straight line ----- straight line

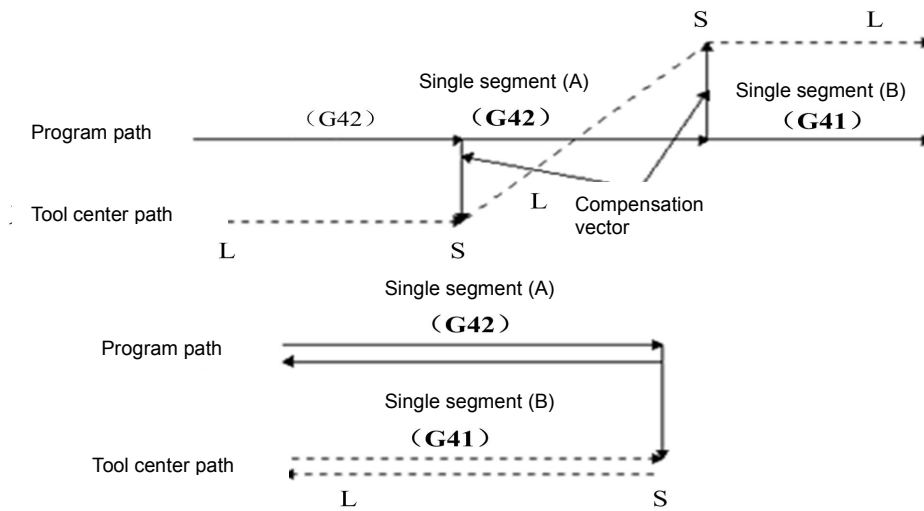

Fig. 4-6-2-2-2 Straight Line – Straight Line

ii) Straight line ----- arc

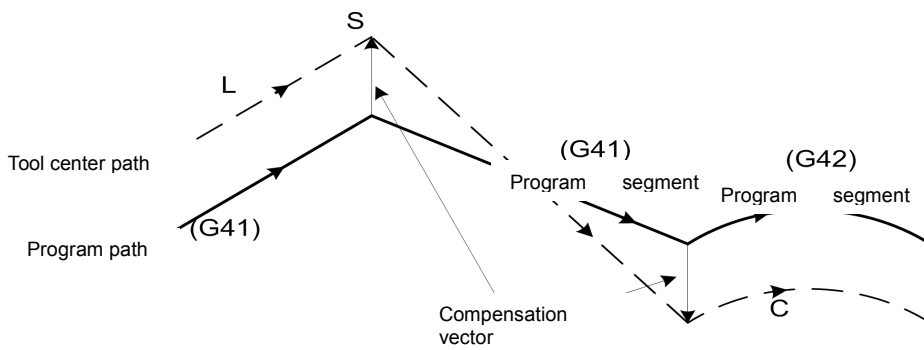

Fig. 4-6-2-2-3 Straight Line - Arc, No Intersection Point (Change Compensation Direction)

iii) Arc ----- arc

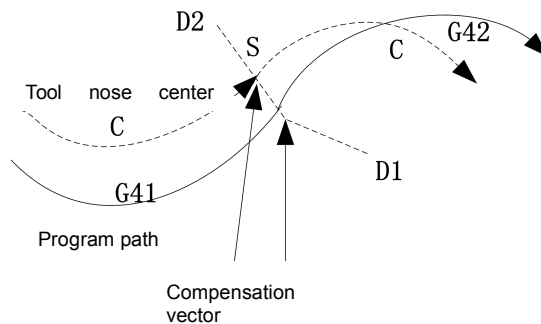

Fig. 4-6-2-2-4 Arc - Arc, No Intersection Point (Change Compensation Direction)

4.6.2.3 Temporary cancellation of tool compensation

If the following instructions are assigned in compensation mode, the compensation vector will be temporarily cancelled and followed by automatic recovery.

In such case, the tool will directly move to the instruction point where compensation vector is cancelled from the intersection point, which is different from the compensation cancellation mode. If compensation mode is recovered, the tool will be directly moved to the intersection point.

G90, G92, G94 fixed circulation, G71~G76 fixed circulation.

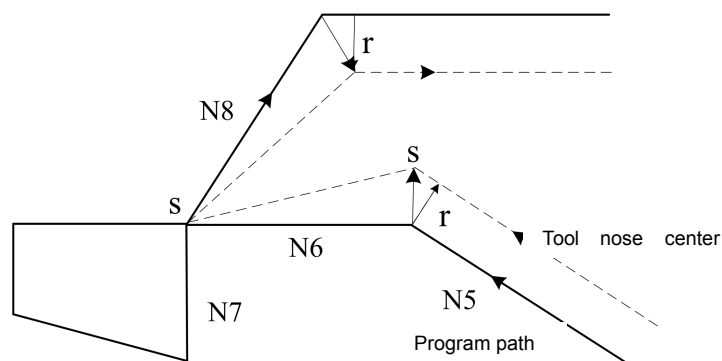

Fig. 4-6-2-3-1 Temporary Cancellation of Tool Compensation ②

```

N1 T0101
N2 G0 X100 Z100
N3 G0 X0 Z0
N4 G42 G90 X-20 W-50 F500      (Tool compensation is cancelled temporarily here)
N5 G0 X50 Z50                  (Tool compensation recovered)
N6 G0 X100 Z100
N7 M30
    
```

4.6.2.4 Non movement instruction contained in tool compensation

1. Non movement instrument is available at beginning of compensation

No compensation vector will be generated if tool is not moved according to instruction at beginning of compensation.

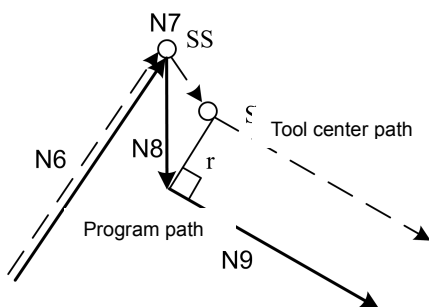

```

N1 T0101;
N2 G0 X0 Z0;
N3 G01 U-30 W20 F500;
N4 G42 U0;
N5 U30;
N6 U20 W20;
N7 G40 G0 X100 Z100;
N8 M30;
    
```

Fig. 4-6-2-4-1 Non Movement Instruction Available at Beginning of Tool Compensation

2. Non movement instruction available at compensation mode

If only one program segment without tool movement is assigned in compensation mode, the vector and tool center path should be the same with the case that this program segment is not assigned. (For details, please refer to tool compensation in Article 4.6.2.1) This program segment without tool movement should be executed at the stop point of single program segment.

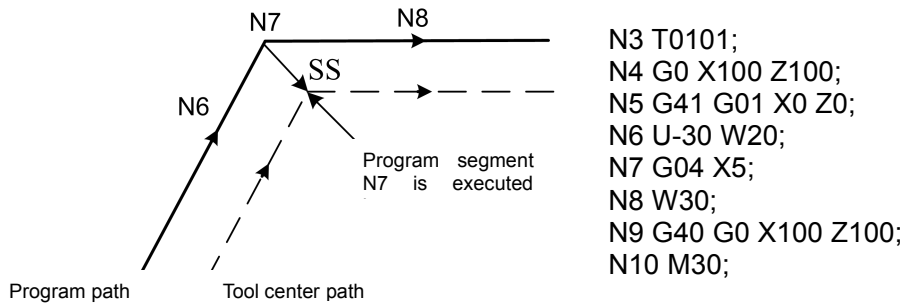

Fig. 4-6-2-4-2 Non Movement Instruction Available at Tool Compensation

3. Non movement instruction available at compensation cancellation

If there's no tool movement in the program segment assigned together with compensation cancellation, it will form a vector which has the length of compensation amount and direction vertical to the movement direction of previous program segment. This vector will be cancelled in the next movement instruction.

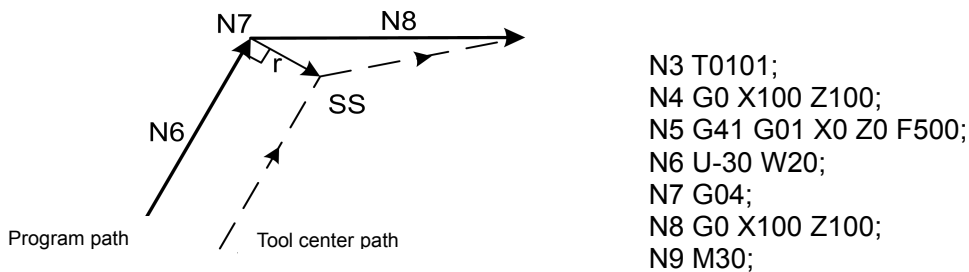

Fig. 4-6-2-4-3 Non Movement Instruction Available at Tool Compensation

4.6.2.5 Check of tool compensation interference

The excessive cutting of tool is called "Interference". Check of tool compensation interface, which can be used for checking the potential excessive cutting of tool, should be implemented even if excessive cutting is not occurred.

(a) Basic conditions for interface

- (1) The path between tool and program is different. (The included angle between paths is 90° - 270°).
- (2) In arc processing, the included angle between start and end point of tool and program has great differences (above 180°), except for the conditions.

Case ①

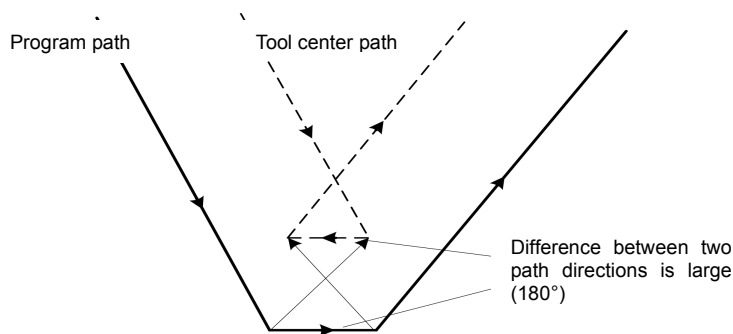

Fig. 4-6-2-5-1 Tool Interference ①

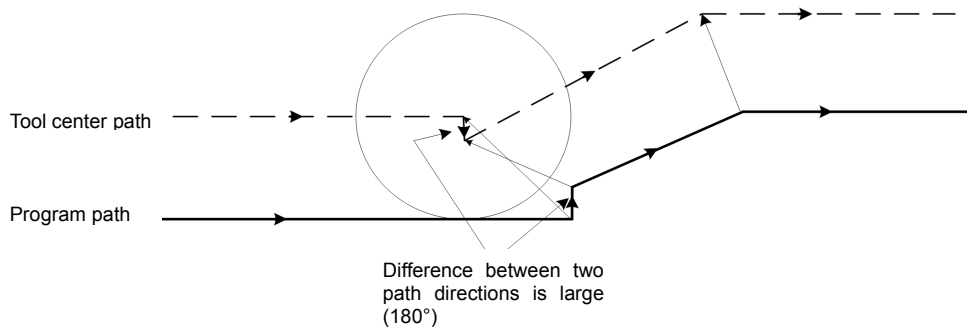

Fig. 4-6-2-5-2 Tool Compensation Interference ②

(b) Interference case

(1) The depth is lower than compensation amount.

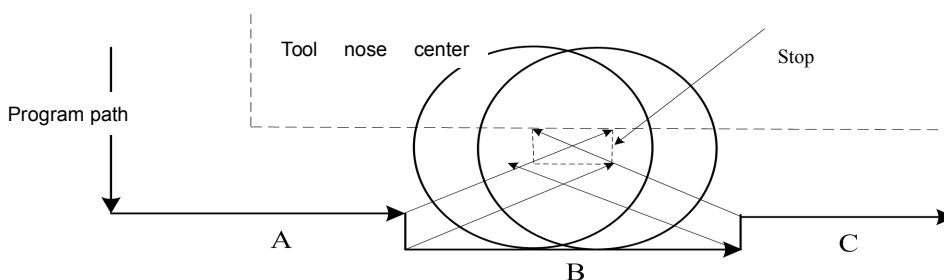

Fig. 4-6-2-5-3 Tool Compensation Interference Case ①

Program is as follows:

```

N1 T0101;                                (R<=10)
N2 G0 X0 Z30;
N3 G42 G01 X50 Z0 F500;
N4 U50;
N5 W20;
N6 U10;
N7 W20;
N8 U-10;
N9 W20;
N10 G40 G0 X0 Z30;
N11 M30;
    
```

In the aforementioned programs, the tool nose radius compensation value of No. 01 tool is **R<=10**, and tool compensation is implemented normally; if **R>10**, the system will give out interference alarm, since the direction of Program C in program segment is opposite to the path of tool radius compensation.

(2) Concave depth is lower than compensation amount

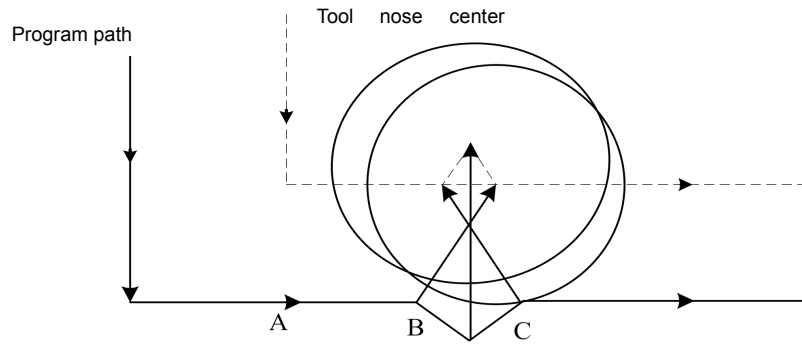

Fig. 4-6-2-5-4 Tool Compensation Interference Case ②

Program is as follows:

```

N1 T0101;                                (R<=25)
N2 G0 X0 Z30;
N3 G42 G01 X50 Z0 F500;
N4 U50;
N5 W20;
N6 U10 W10;
N7 U-10 W10;
N8 W20;
N9 G40 G0 X0 Z30;
N10 M30;
    
```

In the aforementioned programs, the tool nose radius compensation value of No. 01 tool is **R<=25**, and tool compensation is implemented normally; if **R>25**, the system will give out interference alarm, since the direction of Program C in program segment is opposite to the path of tool radius compensation.

4.6.2.6 Tool nose radius compensation in Code G90/G94

As for circular paths, the tool nose center path is in parallel to the program path in general. For both of Mode G41 and G42, the offset direction is as shown in figure below.

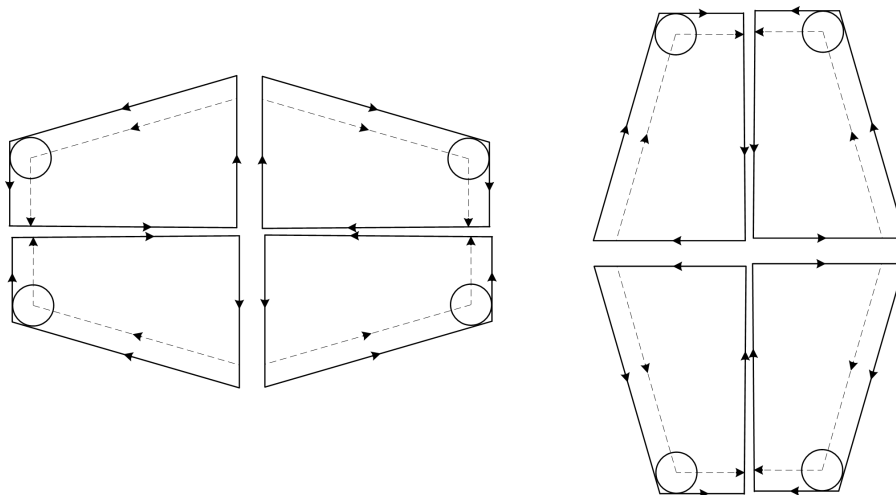

Fig. 4-6-2-6-1 G90/G94 Tool Nose Radius Compensation

4.6.2.7 Tool nose radius compensation in Code G70

Tool nose radius compensation can be realized in fine processing circulation (G70). Tool center path will have automatic offset of one compensation value along with fine processing path. If G70 tool nose radius compensation is realized, G70 can be executed together with G41/G42 in the same segment, or G41/G42 can be assigned in fine processing circulation segment.

4.6.3 Notice for tool compensation C

1. If 30 or more progress segments without movement instructions are continuously assigned in compensation process, it will give out an alarm. For example:

```
N1 M05;..... Code M output
N2 S21;..... Code S output
N3 G04 X10;..... Pause
.....
N29 G01 U;.....Zero movement distance
N30 G9;.....Only Code G available.
```

2. If program segment is executed in input mode (MDI), tool nose radius compensation is available.
3. The system will immediately enter cancellation mode after startup or in execution of M30. The program must be ended in cancellation mode; otherwise, the tool may fail to be positioned at end point, but stay at the position which equals to the length of a vector from end point.
4. Tool nose radius compensation can be established or cancelled through Code G00 or G01 only, instead of arc code (G02 or G03). The system will give out alarm if it is assigned.
5. If compensation amount is negative, G41 and G42 will have mutual exchange on program. If tool center moves along with exterior side of workpiece, the tool will move along with the inner, and vice versa, since the tool nose offset direction will be changed along with the variation of compensation amount symbol, but the assumed tool nose direction maintains unchanged. Therefore, it should not be changed without permission.
6. Generally, compensation amount should be changed when cancelling mode or switching tool. New compensation amount is not effective, unless the tool offset is executed again.
7. If tool compensation program is being executed, Code G will be maintained to be G41 or G42 as before if there's error or alarm; in such case, tool compensation state C can be directly cancelled by pressing rest button.

4.6.4 Example of tool compensation processing C

Example of tool compensation processing C ①:

The spare parts shown in Fig. 4-6-4-1 below should be processed. The size of spare parts is shown in figure; tool nose radius R=1 and it is the first tool.

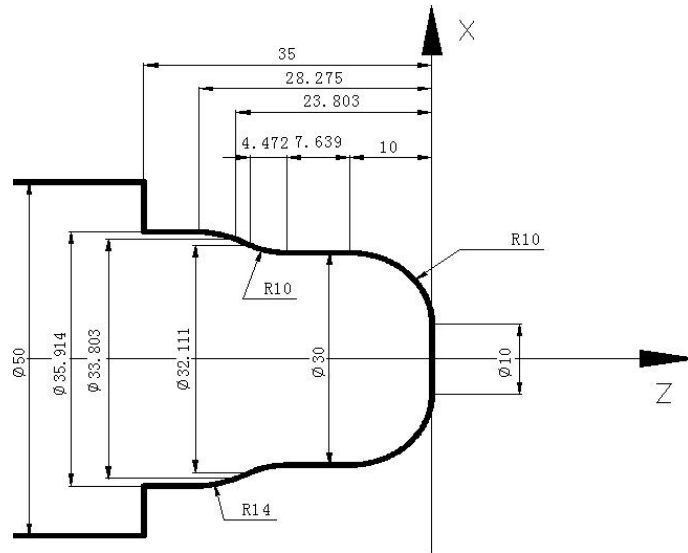

Fig. 4-6-4-1 Example of Tool Compensation C ①

Program is as follows:

```

O0001;
N010 G0 X100.0 Z100.0;    (Positioned to safe position)
N020 M3 S300;             (Spindle rotates anticlockwise, revolving speed: 300r/min)
N030 M8;                  (Cooling activated)
N040 T0101;               (Switched to No. 1 tool for compensation)
N050 G00 X10.0 Z10.0;     (Quick positioning and close to workpiece)
N060 G42 G1 Z0 F80;       (Start execution of tool nose radius compensation)
N070 G3 X30 Z-10 R10;
N080 G1 Z-17.639;
N090 G2 X32.111 Z-22.111 R10;
N100 G1 X33.803 Z-23.803;
N110 G3 X35.914 Z-28.275 R14;
N120 G1 Z-35;
N130 X50;
N140 G40 G0 X80 Z80;      (Cancel tool nose radius compensation)
N150 M09;                 (Cooling deactivated)
N160 G00 X100.0 Z100.0 T0200; (Quick return to safe position, switch to basic tool and
reset tool offset)
N170 M30;                 (Program complete)
    
```

Example of tool compensation C ②:

The spare parts shown in Fig. 4-6-4- 2 below should be processed. The size of spare parts is shown in figure; tool nose radius R=1 and it is the first tool.

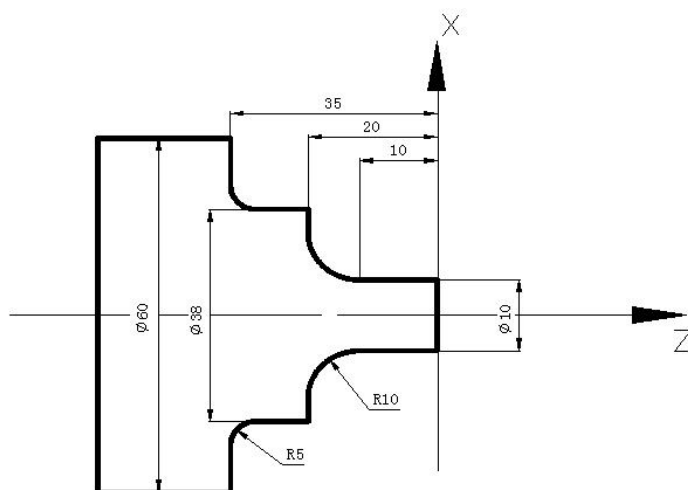

Fig. 4-6-4-2 Example of Tool Compensation C ②

```

O0002
N1 G0 X100 Z100;
N2 M3 S800;
N3 M8;
N4 T0202;
N5 G0 X70 Z10;
N6 G71 U3 R1;
N7 G71 P8 Q14 U0 W0 F120;
N8 G0 X10;
N9 G1 Z-10 F80;
N10 G02 X30 W-10 R10;
N11 G1 X38;
N12 Z-30;
N13 G02 X48 W-5 R5;
N14 G1 X60;
N15 G0 X100 Z80;
N16 M3 S300;
N17 T0101;
N18 G0 X70 Z10;
N19 G42 G70 P8 Q14; (Tool nose radius compensation is jointly executed by G42 and G70
in the same segment)
N20 G40 G0 X80 Z50; (Cancel tool nose radius compensation)
N21 G0 X100 Z100 T0200;
N22 M30;

```

Example of tool compensation C ③:

The spare parts shown in Fig. 4-6-4-3 below should be processed. The size of spare parts is shown in figure; tool nose radius $R=1$ and it is the first tool.

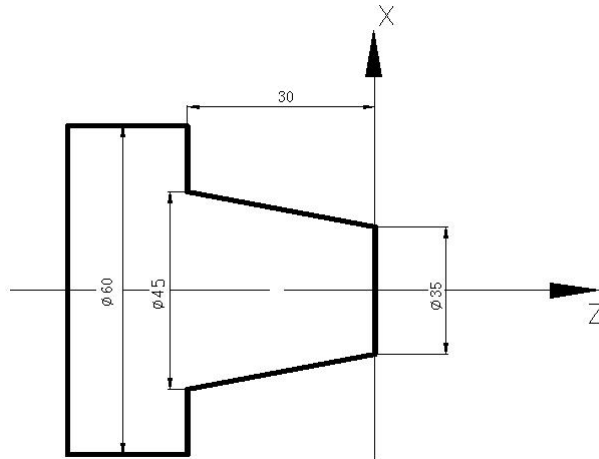

Fig. 4-6-4-3 Tool Compensation C Case ③

```

O0003
N1 G0 X100 Z100;
N2 M3 S800;
N3 M8;
N4 T0101;
N5 G42 G0 X70 Z10;      (Start execution of tool nose radius compensation)
N6 G90 X45 Z-30 R-5 F80;
N7 G40 G0 X80 Z80;      (Cancel tool nose radius compensation)
N8 G0 X100 Z100 T0100;
N9 M30;
    
```

4.7 Code G of Macro Function

4.7.1 User's macroprogram

Certain functions, which are realized by one group of codes, are pre-saved in memory and these functions are represented by one code. These functions can be automatically realized if the user writes out the representative codes. Such group code is called user's macroprogram body and representative code is called "User's macroprogram". The user's macroprogram body and user's macroprogram are respectively called macroprogram or macroprogram call code for short.

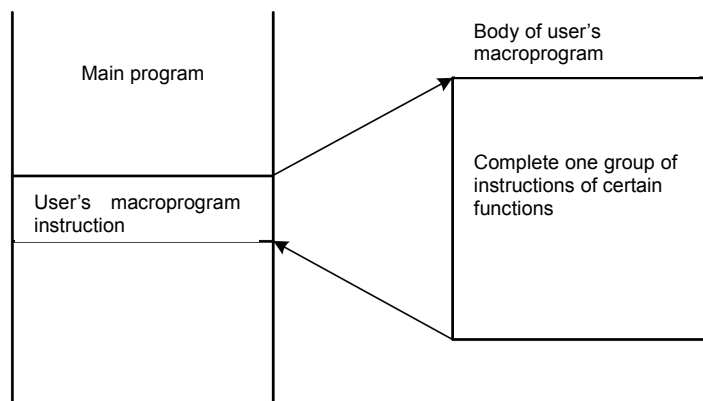

Fig. 4-7-1-1

Variables can be used in user's macroprogram body. Variables can be calculated and be given variable assignment by macroprogram.

4.7.2 Macro variables

General CNC instruction, or variables, can be used in user's macroprogram for calculation and transfer of code.

User's macroprogram should be started from program number and ended by M99.

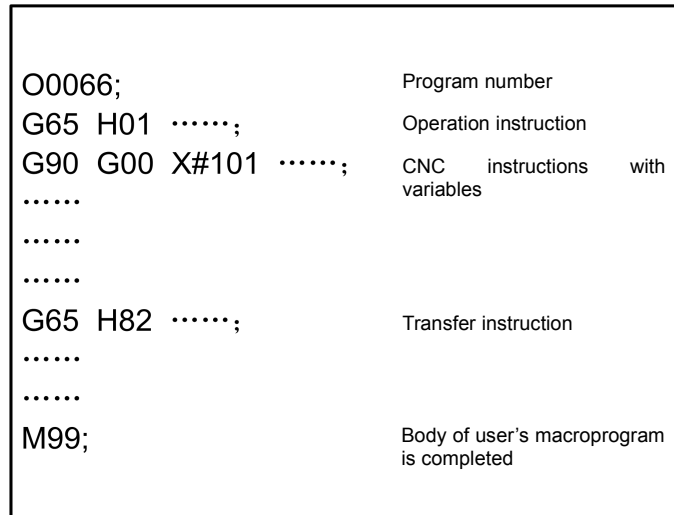

Fig. 4-7-2-1 (Composition of User's Macroprogram Body)

1. Use Method of Variable

The parameter value in user's macroprogram body can be assigned by variable. Such variable can be assigned by main program or set through LCD/MDI, or be assigned when user's macroprogram body is executed.

Multiple variables can be used and distinguished by variable number:

(1) Expression of variable

Variable is expressed by variable number after # and format is as follows:

#i (i = 1, 2, 3, 4

(Example) #5, #109, #1005

(2) Quotation of variable

Value after reference value can be exchanged by variable.

(Example) F#103 if #103 = 15, it should be the same with F15 instruction.

G#130 if #130 = 3, it should be the same with G3.

Note: 1. Variable cannot be quoted by parameter word O and N (program and sequence number). O#100 and N#120 should not be used for programming.

2. It should not be used if exceeding the maximum code specified by parameter code. If #30 = 120, M#30 exceeds the maximum code.

3. Display and setting of variable: variable can be displayed on LCD picture, or set through MDI method.

2. Type of Variable

Variables can be divided into null variable, partial variable, public variable and system variable according to the difference of variables, and they are of difference applications and properties.

(1) Null variable #0; (this variable is null and cannot be assigned)

- (2) Partial variable #1~#50: Partial variables can be used in macroprogram for data storage; position parameter NO; it can be set as elimination after reset or emergency stop through 52#7. Partial variable is assigned by independent variable when macroprogram is called.
- (3) Public variable #100~#199, #500~#999: position reference NO; it can be set as elimination of public variable after reset or emergency stop through 52#6.

Public variable is common in main program and user's macroprogram called by main program, that is to say, the variable #i used in user's macroprogram is the same with #i used in other macroprograms. Therefore, the public variable #1 in calculation result of certain macroprogram can be used in other macroprograms.

Application of public variable is not specified in system and can be freely used by user.

Table 4-7-2-1

Variable Number	Variable Type	Function
#100~#199	Public variable	It is cleared after being powered off, and reset to "Null" after being powered on
#500~#999		Data should be saved in file to prevent loss even if it is powered off

(4) System variable: system variable is used for reading and writing the variations of data in CNC running. It is as follows:

- 1) Interface input signal #1000 --- #1015 (Signal from PLC to system is read by digit, i.e. Signal G)
#1032 (Signal from PLC to system is read by digit, i.e. Signal G)
- 2) Interface output signal #1100 --- #1115 (Signal outputted to PLC by digit, i.e. Signal F)
#1132 (Signal outputted to PLC by byte, i.e. Signal F)
- 3) Tool length compensation value #1500 --- #1799 (read-write supported)
- 4) Length wear compensation value #2000 --- #2299 (read-write supported)
- 5) Tool radius compensation value #1800 --- #1899 (read-write supported)
- 6) Radius wear compensation value #2300 --- #2399 (read-write supported)
- 7) Assumed tool nose #1900---#1999 (read-write supported)
- 8) Alarm #3000
- 9) User data sheet #3500 --- #3755 (read-only)
- 10) Modal information #4000 --- #4030 (read-only)
- 11) Position information #5001 --- #5030 (read-only)
- 12) Workpiece zero point offset #5201 --- #5235 (read-only)
- 13) Additional workpiece coordination system #7001 --- #7250 (read-write supported)

3. Detailed Introduction to System Variable

- 1) Modal information

Table 4-7-2-2

Variab le No.	Function	Group No.
#4000	G04,G28,G31,G50,G65,G70,G71,G72,G73,G74,G75,G76	Group 00
#4001	G00,G01,G02,G03,G32,G34,G90,G92,G94	Group 01
#4002	G96,G97	Group 02
#4003	To be extended	Group 03
#4004	To be extended	Group 04
#4005	G98, G99	Group 05
#4006	G20,G21	Group 06
#4007	G40,G41,G42	Group 07
#4008	To be extended	Group 08
#4009	To be extended	Group 09
#4010	To be extended	Group 10
#4011	To be extended	Group 11
#4012	To be extended	Group 12
#4013	To be extended	Group 13
#4014	G54,G55,G56,G57, G58,G59	Group 14
#4015	To be extended	Group 15
#4016	G17,G18,G19	Group 16
#4017	To be extended	Group 17
#4018	To be extended	Group 18
#4019	To be extended	Group 19
#4020	To be extended	Group 20
#4021	To be extended	Group 21
#4022	D	
#4023	H	
#4024	F	
#4025	M	
#4026	S	
#4027	T	
#4028	N	
#4029	O	
#4030	P (additional workpiece coordination system selected)	

Note 1: Code P means additional workpiece coordination system selected.

Note 2: If G#4002 is executed, the value obtained from #4002 is 17, 18 or 19.

Note 3: Modal information is read-only.

2) Information of current position

Table 4-7-2-3

Variable No.	Position Information	Relevant Coordination Systems	Read Operation in Movement	Tool Compensation Value
#5001	X-axis program segment end position (ABSIO)	Workpiece coordination system	Available	Tool nose position (program instruction position) not considered
#5002	Y-axis program segment end position (ABSIO)			
#5003	Z-axis program segment end position (ABSIO)			
#5004	The 4 th axis program segment end position (ABSIO)			
#5006	X-axis program segment end position (ABSMT)	Machine tool coordination system	N/A	Tool benchmark position (machine tool coordinate) considered
#5007	Y-axis program segment end position (ABSMT)			
#5008	Z-axis program segment end position (ABSMT)			
#5009	The 4 th axis program segment end position (ABSMT)			
#5011	X-axis program segment end position (ABSOT)	Workpiece coordination system	Available	Tool benchmark position (machine tool coordinate) not considered
#5012	Y-axis program segment end position (ABSOT)			
#5013	Z-axis program segment end position (ABSOT)			
#5014	The 4 th axis program segment end position (ABSOT)			
#5016	X-axis program segment end position (ABSKP)			
#5017	Y-axis program segment end position (ABSKP)	N/A	N/A	
#5018	Z-axis program segment end position (ABSKP)			
#5019	The 4 th axis program segment end position (ABSKP)			
#5021	X-axis tool length compensation value			
#5022	Y-axis tool length compensation value	N/A	N/A	
#5023	Z-axis tool length compensation value			
#5024	The 4 th axis tool length			

Variable No.	Position Information	Relevant Coordination Systems	Read Operation in Movement	Tool Compensation Value
	compensation value	/		
#5026	X-axis servo position compensation			
#5027	Y-axis servo position compensation			
#5028	Z-axis servo position compensation			
#5029	The 4 th axis servo position compensation			

Note 1: ABSIO: end point coordination of previous program segment in workpiece coordination system.

Note 2: ABSMT: machine tool coordination system, position of present machine tool coordination system.

Note 3: ABSOT: workpiece coordination system, position of present coordination.

Note 4: ABSKP: workpiece coordination system, effective position of hopping signals in program segment G31.

3) Offset of workpiece zero point and additional zero point:

Table 4-7-2-4

Variab le No.	Function
#5201	External workpiece zero offset of the 1 st axis
...	...
#5204	External workpiece zero offset of the 4 th axis
#5206	Zero offset of workpiece G54 of the 1 st axis
...	...
#5209	Zero offset of workpiece G54 of the 4 th axis
#5211	Zero offset of workpiece G55 of the 1 st axis
...	...
#5214	Zero offset of workpiece G55 of the 4 th axis
#5216	Zero offset of workpiece G56 of the 1 st axis
...	...
#5219	Zero offset of workpiece G56 of the 4 th axis
#5221	Zero offset of workpiece G57 of the 1 st axis
...	...
#5224	Zero offset of workpiece G57 of the 4 th axis
#5226	Zero offset of workpiece G58 of the 1 st axis
...	...
#5229	Zero offset of workpiece G58 of the 4 th axis
#5231	Zero offset of workpiece G59 of the 1 st axis
...	...
#5234	Zero offset of workpiece G59 of the 4 th axis
#7001	Zero offset of workpiece G54 P1 of the 1 st axis
...	...
#7004	Zero offset of workpiece G54 P1 of the 4 th axis
#7006	Zero offset of workpiece G54 P2 of the 1 st axis
...	...
#7009	Zero offset of workpiece G54 P2 of the 4 th axis
#7246	Zero offset of workpiece G54 P50 of the 1 st axis
...	...
#7249	Zero offset of workpiece G54 P50 of the 4 th axis

4. Partial Variable

Corresponding relation between address and partial variable:

Table 4-7-2-5

Address of Independent Variable	Partial Variable No.	Address of Independent Variable	Partial Variable No.
A	#1	Q	#17
B	#2	R	#18
C	#3	S	#19
I	#4	T	#20
J	#5	U	#21
K	#6	V	#22
D	#7	W	#23
E	#8	X	#24
F	#9	Y	#25
M	#13	Z	#26

Note 1: assignment can be made by adding figure after English letters. All English letters, except for G, L, O, N, H and P can be used for assignment of independent variable; each letter can be used for one assignment from A-B-C-D... to X-Y-Z; it is not needed to follow the sequence of letter for assignment; address without assignment can be omitted.

Note 2: G65 must be assigned before using any independent variable.

5. Notice for User's Macroprogram Body

Press Key # behind reference word G, X, Y, Z, R, I, J, K, F, H, M, S, T, P and Q to input the #

2) It can assign calculation and transfer code in MDI state.

3) H, P, Q and R of calculated and transferred code should be used as parameters as Instruction G65 whether they are placed at front or rear side of G65.

H02 G65 P#100 Q#101 R#102: Correct

N100 G65 H01 P#100 Q10: Correct

4) Input range of variable should not exceed 15-digit significant figure, calculation result should not exceed 9-digit integer and manual input range of variable should be 8-digit effective figure.

5) Calculation result of variable can be decimal with precision reaching 0.0001. Decimal points should not be omitted, except for the calculation process of H11 (OR), H12 (AND), H13 (NOT) and H23 (MOD).

For example:

#100 = 35, #101 = 10, #102 = 5

#110 = #100÷#101 (=3.5)

#111 = #100×#102 (=17.5)

#120 = #100×#102 (=175)

#121 = #120÷#101 (=17.5)

6) The time for executing calculation and transfer of code may change along with varying conditions. Average value can be 10ms.

7) If variable value is undefined, it will become "Null" variable. Variable #0 is null variable which is read-only.

a. Quote

If an undefined variable is quoted, the address itself will be omitted.

For example:

If variable #1 is 0 and variable #2 is null, the execution result of G00X#1 Y#2 is G00X0;

b. Calculation

<Null> should be the same with 0 in other conditions, except for assignment via <Null>.

Table 4-7-2-6

If #1=<Null>	If #1=0
#2=#1 ↓ #2=<Null>	#2=#1 ↓ #2=0
#2=#1*5 ↓ #2=0	#2=#1*5 ↓ #2=0
#2=#1+#1 ↓ #2=0	#2=#1+#1 ↓ #2=0

c. Conditional expression

<Null> in EQ and NE is different from 0.

Table 4-7-2-7

If #1=<Null>	If #1=0
#1 EQ #0 ↓ True	#1 EQ #0 ↓ False
#1 NE #0 ↓ True	#1 NE #0 ↓ True
#1 GE #0 ↓ True	#1 GE #0 ↓ True
#1 GT #0 ↓ False	#1 GT #0 ↓ False

COMMON VARIABLES		00001	1/000041
NO.	DATA	NO.	DATA
0000		0012	
0001		0013	
0002		0014	
0003		0015	
0004		0016	
0005		0017	
0006		0018	
0007		0019	
0008		0020	
0009		0021	
0010		0022	
0011		0023	

NOTE: NULL VARIABLES

DATA	^	S00000	T0700
		14: 02: 38	AUTO
	CUSTOMER	SYSTEM	RETURN

Fig. 4-7-2-2

Variable is null if it is blank.

4.7.3 Non-modal call of G65

If G65 is assigned, the user's macroprogram assigned by Address P is called the data are transferred to user's macroprogram body through independent variable.

Format is as follows:

G65 P L <Assignment of independent variable>;

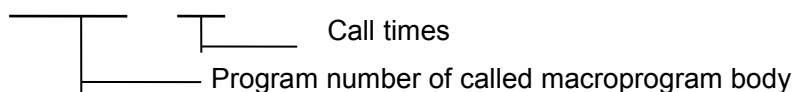

It is needed to, behind G65, assign program number of user's macroprogram using Address P, assign macroprogram call times using L and transfer data to macroprogram using independent variables.

If repeat is needed, assign repeat times from 1 to 9999 behind Address L; the default repeat time is 1 is L is omitted.

If assignment is made using independent variable, the value will be assigned to corresponding partial variable.

Note 1: the system may give out alarm (PS 078) if failing to search the subprogram number assigned by Address P.

Note 2: subprogram numbered 90000~99999 is reserved program for the system; if such subprogram is called by user, the system can execute their contents, but stay cursor at Code G65 segment and contents of major programs are constantly displayed on program interface. (Position parameter N0: 27#4 can be modified to display the contents of subprogram).

Note 3: a total of five layers can be nested in the call of macroprogram.

4.7.4 Function A of user's macroprogram

1. General form:

G65 Hm P#i Q#j R#k;

m: 01~99 means the function of code calculation or transfer.

#i: variable name of stored calculation result.

#j: variable name 1 of calculation. It can be constant. Constant is directly expressed without #.
 #k: variable name 2 of calculation. It can be constant.

Meaning: $\#i = \#j \circ \#k$
 ———— Calculation symbol, assigned by Hm

(Example) P#100 Q#101 R#102.....#100 = #101 \circ #102;
 P#100 Q#101 R15#100 = #101 \circ 15;
 P#100 Q-100 R#102.....#100 = -100 \circ #102

Code H assigned by G65 has no influence on selection of offset.

Code G	Code H	Function	Definition
G65	H01	Assignment	$\#i = \#j$
G65	H02	Add	$\#i = \#j + \#k$
G65	H03	Subtract	$\#i = \#j - \#k$
G65	H04	Multiply	$\#i = \#j \times \#k$
G65	H05	Divide	$\#i = \#j \div \#k$
G65	H11	Logic add (or)	$\#i = \#j \text{ OR } \#k$
G65	H12	Logic multiply (and)	$\#i = \#j \text{ AND } \#k$
G65	H13	Exclusive or	$\#i = \#j \text{ XOR } \#k$
G65	H21	Square root	$\#i = \sqrt{\#j}$
G65	H22	Absolute value	$\#i = \#j $
G65	H23	Take remainder	$\#i = \#j - \text{trunc}(\#j \div \#k) \times \#k$
G65	H26	Compound multiplication and calculation	$\#i = (\#i \times \#j) \div \#k$
G65	H27	Composite square root	$\#i = \sqrt{\#j^2 + \#k^2}$
G65	H31	Sine	$\#i = \#j \times \text{SIN}(\#k)$
G65	H32	Cosine	$\#i = \#j \times \text{COS}(\#k)$
G65	H33	Tangent	$\#i = \#j \times \text{TAN}(\#k)$
G65	H34	Arc tangent	$\#i = \text{ATAN}(\#j/\#k)$
G65	H80	Unconditional transfer	Direction N
G65	H81	Conditional transfer 1	IF $\#i = \#k$, GOTO N
G65	H82	Conditional transfer 2	IF $\#i \neq \#k$, GOTO N
G65	H83	Conditional transfer 3	IF $\#i > \#k$, GOTO N
G65	H84	Conditional transfer 4	IF $\#i < \#k$, GOTO N
G65	H85	Conditional transfer 5	IF $\#i \geq \#k$, GOTO N
G65	H86	Conditional transfer 6	IF $\#i \leq \#k$, GOTO N
G65	H89	Alarm	

Fig. 4-7-4-1

2. Operation code:

1) Assignment of variable: $\#I = \#J$

G65 H01 P#I Q#J;

(Example) G65 H01 P#101 Q1005; (#101 = 1005)
 G65 H01 P#101 Q#110; (#101 = #110)
 G65 H01 P#101 Q-#102; (#101 = -#102)

2) Add operation: $\#I = \#J + \#K$

G65 H02 P#I Q#J R#K;

(Example) G65 H02 P#101 Q#102 R15; (#101 = #102+15)

3) Subtract operation: $\#I = \#J - \#K$

G65 H03 P#I Q#J R#K;

(Example) G65 H03 P#101 Q#102 R#103; (#101 = #102-#103)

4) Multiply operation: $\#I = \#J \times \#K$

G65 H04 P#I Q#J R#K;

(Example) G65 H04 P#101 Q#102 R#103; (#101 = #102×#103)

5) Division operation: # I = # J÷# K

G65 H05 P#I Q#J R#K;

(Example) G65 H05 P#101 Q#102 R#103; (#101 = #102÷#103)

6) Logic add (or): # I = # J.OR. # K

G65 H11 P#I Q#J R#K;

(Example) G65 H11 P#101 Q#102 R#103; (#101 = #102.OR. #103)

7) Logic multiply (and): # I = # J.AND. # K

G65 H12 P#I Q#J R#K;

(Example) G65 H12 P# 101 Q#102 R#103; (#101 = #102.AND.#103)

8) XOR: # I = # J.XOR. # K

G65 H13 P#I Q#J R#K;

(Example) G65 H13 P#101 Q#102 R#103; (#101 = #102.XOR. #103)

9) Square root: # I = $\sqrt[\#]{\#}$

G65 H21 P#I Q#J;

(Example) G65 H21 P#101 Q#102 ; (#101 = $\sqrt{\#102}$)

10) Absolute value: # I = | # J |

G65 H22 P#I Q#J;

(Example) G65 H22 P#101 Q#102; (#101 = | #102 |)

11) MOD: # I = # J-RUNC(#J/#K)×# K, TRUNC: Rounding decimal

G65 H23 P#I Q#J R#K;

(Example) G65 H23 P#101 Q#102 R#103; (#101 = #102- TRUNC (#102/#103)×#103)

12) Compound multiply operation: # I = (# I×# J)÷# K

G65 H26 P#I Q#J R# k;

(Example) G65 H26 P#101 Q#102 R#103; (#101 = (#101×# 102)÷#103)

13) Compound square root: # I = $\sqrt[\#]{\#^2+\#k^2}$

G65 H27 P#I Q#J R#K;

(Example) G65 H27 P#101 Q#102 R#103; (#101 = $\sqrt{\#102^2+\#103^2}$)

14) Sine: # I = # J•SIN (# K) (Unit: °)

G65 H31 P#I Q#J R#K;

(Example) G65 H31 P#101 Q#102 R#103; (#101 = #102•SIN (#103))

15) Cosine: # I = # J•COS (# K) (Unit: °)

G65 H32 P#I Q#J R# K;

(Example) G65 H32 P#101 Q#102 R#103; (#101 =#102•COS (#103))

16) Tangent: # I = # J•TAN (# K) (Unit: °)

G65 H33 P#I Q#J R# K;

(Example) G65 H33 P#101 Q#102 R#103; (#101 = #102•TAN (#103))

17) Arc tangent: # I = ATAN (# J /# K) (Unit: °)

G65 H34 P#I Q#J R# K;

(Example) G65 H34 P#101 Q#102 R#103; (#101 =ATAN (#102/#103))

Note 1: unit of angle variable is °.

Note 2: if necessary Q and R are not assigned in operation, they should be regarded as 0 in operation.

Note 3: trunc: rounding operation, rounding decimal.

3. Transfer Instruction

1) Unconditional transfer

G65 H80 Pn; n: sequence number

(Example) G65 H80 P120; (Transferred to Program Segment N120)

2) Conditional transfer 1 #J.EQ.# K (=)

G65 H81 Pn Q#J R# K; n: sequence number

(Example) G65 H81 P1000 Q#101 R#102;

If # 101 = #102, transfer to Program Segment N1000; if #101 ≠ #102, execute program by sequence.

3) Conditional transfer 2 #J.NE.# K (≠)

G65 H82 Pn Q#J R# K; n: sequence number

(Example) G65 H82 P1000 Q#101 R#102;

If # 101 ≠ #102, transfer to Program Segment N1000; if # 101 = #102, execute program by sequence.

4) Conditional transfer 3 #J.GT.# K (>)

G65 H83 Pn Q#J R# K; n: sequence number

(Example) G65 H83 P1000 Q#101 R#102;

If #101 > #102, transfer to Program Segment N1000; if #101 ≤ #102, execute program by sequence.

5) Conditional transfer 4 #J.LT.# K (<)

G65 H84 Pn Q#J R# K; n: sequence number

(Example) G65 H84 P1000 Q#101 R#102;

If # 101<#102, transfer to Program Segment N1000; if #101 ≥ #102, execute program by sequence.

6) Conditional transfer 5 #J.GE.# K (≥)

G65 H85 Pn Q#J R# K; n: sequence number

(Example) G65 H85 P1000 Q#101 R#102;

If # 101 ≥ #102, transfer to Program Segment N1000; if #101<#102, execute program by sequence.

7) Conditional transfer 6 #J.LE.# K (≤)

G65 H86 Pn Q#J R# K; n: sequence number

(Example) G65 H86 P1000 Q#101 R#102;

If # 101≤ #102, transfer to Program Segment N1000; if #101>#102, execute program by sequence.

Note: sequence number can be assigned by variable. For example, G65 H81 P#100 Q#101 R#102; if condition is satisfied, program will transfer to the program segment with sequence number assigned by #100.

4. Logic AND, Logic OR and Logic NOT Code

Example:

G65 H01 P#101 Q3;

G65 H01 P#102 Q5;

G65 H11 P#100 Q#101 Q#102;
 5 means binary system is 101, 3 means 011 and calculation result is #100=7;
 G65 H12 P#100 Q#101 Q#102;
 5 means binary system is 101, 3 means 011 and calculation result is #100=1;

5. Macro-variable Alarm

Example:

G65 H99 P1; Macro-variable 3001alarm
 G65 H99 P124; Macro-variable 3124 alarm

4.7.5 Function B of user's macroprogram

1. Arithmetic and logic operation

The operations in the following table can be executed in variable. The expression at right side of operational character contains constant and/or the variable composed of functions or operational character. Variable #j and #k in expression can be replaced by constant. The variable at left side can be assigned by expression.

Table 4-7-5-1 Arithmetic and Logic Operation

Function	Format	Remarks
Definition	#i = #j	
Addition	#i = #j + #k;	
Subtraction	#i = #j - #k;	
Mollification	#i = #j * #k;	
Division	#i = #j / #k;	
Sine	#i = SIN[#j];	Angle should be assigned by °, 90°30' is expressed in 90.5°
Arc sine	#i = ASIN[#j];	
Cosine	#i = COS[#j];	
Arc cosine	#i = ACOS[#j];	
Tangent	#i = TAN[#j];	
Arc tangent	#i = ATAN[#j] / [#k];	
Square root	#i = SQRT[#j];	
Absolute value	#i = ABS[#j];	
Rounding	#i = ROUND[#j];	
Ceil	#i = FUP[#j];	
Floor	#i = FIX [#j];	
Natural logarithm	#i = LN[#j];	
Exponential function	#i = EXP[#j];	
OR	#i = #j OR #k;	
XOR	#i = #j XOR #k;	
AND	#i = #j AND #k;	

		system by byte
Transfer from BCD to BIN	#i = BIN[#j];	Used for handshaking of PMC.
Transfer from BIN to BCD	#i = BCD[#j];	

Note:

(1) Angle unit

Angle unit for Function SIN, COS, ASIN, ACOS, TAN and ATAN is °. For example, 90°30' is expressed in 90.5°.

(2) **ARCSIN** #i = ASIN [#j]

Value range: -90°~90°.

If #j exceeds the range of -1~1, the system will give out alarm.

Variable #j can be replaced by constant.

(3) **ARCCOS** #i = ACOS [#j]

Value range: 180°~0°.

If #j exceeds the range of -1~1, the system will give out alarm.

Variable #j can be replaced by constant.

(4) **ARCTAN** #i = ATAN [#j] / [#k]

Assigned length of two sides and separated by slash (/).

Value range: 0°~360°.

[For example] If #1 = ATAN [-1] / [-1]; #1=225°.

Variable #j can be replaced by constant.

(5) Natural logarithm #i = LN [#j]

If logarithm (#j) is 0 or less than 0, the system will give out alarm.

Variable #j can be replaced by constant.

(6) Exponential function #i = EXP [#j]

If operation result exceeds 99997.453535 (#j is about 11.5129), it may have overflow and give out alarm.

Variable #j can be replaced by constant.

(7) **ROUND (round off) function**

ROUND function should be providing with rounding at the 1st decimal place.

For example:

If #1=ROUND [#2]; #2=1.2345, value of variable 1 is 1.0.

(8) Ceil and floor

While numeric operation is handled by CNC, it is needed to take ceil if absolute value of integral generated from operation is larger than original value; or take floor if it is lower than original value. The negative number should be handled with much caution.

For example:

If #1=1.2, #2=-1.2.

While executing #3=FUP[#1], 2.0 is assigned to #3.
 While executing #3=FIX[#1], 1.0 is assigned to #3.
 While executing #3=FUP[#2], -2.0 is assigned to #3.
 While executing #3=FIX[#2], -1.0 is assigned to #3.

(9) Abbreviation of arithmetic and logic operation instruction

If function is assigned in program, the first two characters of function name can be used for assigning the function. (For details, please see Table 4-10-5-1).

For example:
 ROUND→RO
 FIX→FI

(10) Operation sequence

- ① Function
- ② Multiply and division operation (* / AND)
- ③ Add and subtraction operation (+ - OR XOR)

Example #1 = #2 + #3 * SIN[#4] ;
)

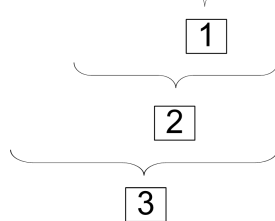

1, 2 and 3 means calculation

(11) Limit

[,] used for closed expression.

If divisor is assigned to be 0 or TAN[90] in division, the system will give out alarm.

2. Transfer and circulation

1) Transfer and circulation

GOTO and IF statement can be used in the program to change the flow direction. Three transfer and circulation operations are available:

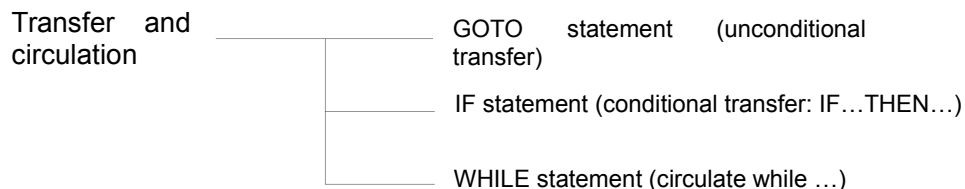

2) Unconditional transfer

➤ **GOTO statement**

Transfer to program segment marked with sequence number n. Sequence number can be assigned by expression.

GOTOn; n: sequence number (1 – 99999)

For example:

GOTO 1;
GOTO #10;

3) Conditional transfer (IF statement) [<Condition expression>]

IF[<Condition expression>]GOTO n

If assigned condition expression is satisfied, transfer to program segment marked with sequence number n; if assigned condition expression is not satisfied, execute the next program segment.

If variable #1 is higher than 10, transfer to program segment with sequence number of N2

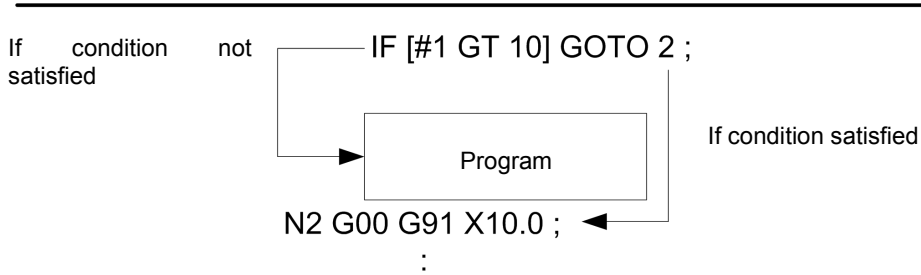

IF[<Condition expression>]THEN

If condition expression is satisfied, execute predetermined macroprogram statement. Only one macroprogram statement is executed.

If #1 equals to #2, 0 is assigned to #3.

IF[#1 EQ #2] THEN #3=0;

Note:

- Conditional expression
Operational character should be included in conditional expression. Operational character is inserted between two variables or between variable and constant, and be closed by brackets ([,]). Variable can be replaced by conditional expression.
- Operational character
Operational character is composed of 2 letters for comparing two values and determining if they are equal to, smaller or higher than another value.

Table 4-7-5-2 Operational Character

Operational Character	Meaning
EQ	Equal to (=)
NE	Unequal to (≠)
GT	Higher than (>)
GE	Higher than or equal to (≥)
LT	Lower than (<)
LE	Lower than or equal to (≤)

➤ Typical program

The following program is used for calculating the sum of value 1~10.

O9500;	
#1=0;	Variable initial value stored
#2=1;	Initial value of added
N1 IF[#2 GT 10]GOTO 2;	Transfer to N2 if added amount is higher than 10
#1=#1+#2;	Calculate sum
#2=#2+1;	Next added value
GOTO 1;	Transfer to N1
N2 M30;	Program complete

4) Circulation (WHILE statement)

One conditional statement is assigned behind WHILE and if condition is satisfied, execute the program from DO to END; otherwise, directly transfer to the program segment behind END.

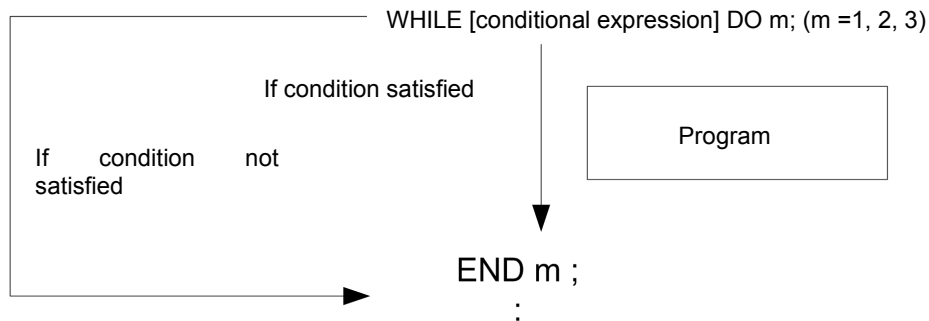

If condition is satisfied, execute the program from DO to END; otherwise, directly transfer to the program segment behind END. This instruction format is applicable to IF statement. The number behind DO and END refers to the mark number of program execution scope. Such mark number should be 1, 2 and 3; otherwise, the system may give out alarm.

Note:

➤ Nest

Mark (1-3) in DO—END circulation can be used for multiple times as needed. But the system will give out alarm if program has crossed and repeated circulation and overlapping within scope of DO.

Note:

➤ Infinite loop

If only WHITE statement, instead of DO, is assigned, an infinite circulation from DO to END will be generated.

➤ Handling time

Retrieval of sequence number will be made while handling GOTO statement with mark transfer. The period of reverse retrieval can be longer than positive retrieval. Handling period can be reduced by using WHITE statement for realizing circulation.

➤ Undefined variable

<Null> and zero have different effects in conditional expression using EQ or NE. <Null> is seen as zero in other forms of conditional expressions.

➤ Typical program

The following program is used for calculating the sum of value 1~10.

```

O0001 ;
#1=0;
#2=1;
WHILE [#2 LE 10] DO 1;
#1=#1+#2;
#2=#2+1;
END 1;
M30;
    
```

Note:

- If G65 is used for call of macroprogram and F for quoting variable, the system should be executed according to variable.
- GOTO statement will have downward research from present program segment and, if failing to research corresponding sequence number, restart research from the beginning of program. It is not recommended to use the same Code N in the same program.
- If variable number is expressed by decimal, the system will directly round off decimal and give no consideration to carry.
- Before major program is completed, the partial variable will be kept and be shared in all subprograms.

Chapter 5 Code M of Auxiliary Function

Code M of this machine tool for users is listed as follows:

Table 5-1

	Code M	Function
Code M for controlling program	M30	Complete program and returning to program heating, add workpiece number by 1
	M02	Complete program and returning to program heating, add workpiece number by 1
	M98	Call of subprogram
	M99	Complete subprogram for return/repeated execution
	M00	Pause program
	M01	Pause selection of program
Code M controlled by PLC	M03	Clockwise rotation of spindle
	M04	Anticlockwise rotation of spindle
	M05	Stop rotation of spindle
	M08	Activate cooling
	M09	Deactivate cooling
	M10	Tailstock forward
	M11	Tailstock back
	M12	Fasten chuck
	M13	Loosen chuck
	M14	Switch from speed control mode to position control mode of spindle
	M15	Switch from position control mode to speed control mode of spindle
	M18	Cancel spindle positioning
	M19	Spindle positioning
	M20	Loosen Axis C
	M21	Fasten Axis C
	M26	M26 output (user-defined)
	M27	Deactivate M26 output
	M28	Cancel rigid tapping
	M29	Rigid tapping instruction
	M32	Open lubricating pump
	M33	Close lubricating pump
	M35	M35 output (user-defined)
	M36	Deactivate M35 output
M41	Gear 1 of spindle	
M42	Gear 2 of spindle	
M43	Gear 3 of spindle	
M44	M44 output (user defined)	
M45	Deactivate M44 output	

Mobile code and auxiliary functions can be simultaneously executed if they are assigned in the same program segment.

If variables behind Address M are assigned, the code signals and gating signals will be sent to machine tool to activate or deactivate these functions. Generally, one Code M can be assigned in one program segment, or at most three M codes can be assigned in the same program segment by setting positioning parameter **N0: 33#7**. However, it may fail to assign the Code M simultaneously due to the restriction of mechanical operation. For detailed about restriction to assignment of multiple M codes in the same program segment, please refer to operation instructions of machine tool manufacturer.

5.1 Code M Controlled by PLC

If Code M controlled by PLC is within the same segment of mobile code, Code M and mobile code should be executed simultaneously.

5.1.1 Code instruction (M03, M04) for positive/reverse rotation of spindle

Code: M03 (M04) Sx x x;

Note:

M03: anticlockwise rotation (positive rotation) of spindle,

M04: clockwise rotation (reverse rotation) of spindle.

Code Sx x x refers to the rotation speed of spindle, or the gear under gear control mode.

Unit: RMP (r/min)

If it is controlled by frequency converter, the Sx x x refers to the actual rotation speed; for example, S1000 refers to the rotation of spindle at speed of 1000r/min.

5.1.2 Spindle rotation stop instruction (M05)

Code: M05, spindle rotation will be stopped if Code M05 is automatically executed, but speed of Code S instruction will be kept. The deceleration mode for spindle stop should be set according to regulations of machine tool manufacturer. Generally, it should be set as power consumption brake.

5.1.3 Cooling activation/deactivation (M08, M09)

Code: M08 - open cooling water pump. M09 – stop cooling water pump. Water pump control codes cannot be executed if auxiliary function is blocked in auto mode.

5.1.4 Chuck control (M12, M13)

Code: exterior chuck: M12, fasten chuck; M13, loosen chuck;

Inner chuck: M12, loosen chuck; M13, fasten chuck.

5.1.5 Switch of spindle speed and position mode (M14, M15)

Code: M14, spindle is switched from speed control mode to position control mode.

M15, spindle is switched from position control mode to speed control mode.

5.1.6 Spindle orientation and cancellation (M18, M19)

Code: M18, cancel spindle orientation. M19 - implement spindle orientation for tool switch and positioning.

5.1.7 Loosen and fasten Spindle C (M20, M21)

Code: M20, loosen Spindle C; M21, fasten Spindle C.

5.1.8 Gear control of spindle (M41, M42, M43 and M44)

Code: M41, Gear 1 of spindle; M42, Gear 2 of spindle; M43, Gear 3 of spindle; M44, Gear 4 of spindle

5.1.9 Lubricating oil control (M32, M33)

Code: M32, open lubricating pump; M33, close lubricating pump.

5.2 Program control Code M

Code M for program control is divided into major program control type and macroprogram control type. If program Control Code M and mobile code is placed in the same segment, it is needed to firstly execute mobile code followed by Code M.

- Note:**
1. Code M00, M01, M02, M30, M98 and M99 should not be assigned together with other M codes; otherwise, the system may give out alarm. If these M codes are assigned in the same segment together with other non-M codes, the non-M codes should be executed firstly.
 2. The Code M includes the ones to make CNC send Code M to machine tool and execute internal operations, such as the Code M which deactivates the pre-reading function of program segment. Besides, the Code M which can make CNC send Code M to machine tool but have no execution of internal operation, can be assigned in the same program segment.

5.2.1 Program end and return (M30, M02)

In auto running mode, the system will stop auto running state when program reaches M30 (M02) and, if the following programs are not executed, it will stop spindle and cooling and workpiece number is increased by 1. M30 can be controlled by parameter **N0: 33#4** whether to return program header; M02 can be controlled by parameter **N0: 33#2** whether to return program header. If M02 and M30 are assigned at end of program, they will be returned to subprogram called and keep executing the following program segments.

5.2.2 Program pause (M00)

In auto running mode, auto running state will be paused when program reaches M00 and in such case, the previous modal information will be saved. Press circulation key to keep running. Its function is equal to holding of key.

5.2.3 Program selection pause (M01)

In auto running mode, auto running state will be paused if program reaches M01. If "Select off" switch is turned to on position, M01 and M00 have the same effects; if turned to off position, M01 has no effects. For detailed operation, please refer to operation manual.

5.2.4 Call of subprogram code instruction (M98)

Code M98 can be programmed in main program for call and execution of subprogram. Detailed format:

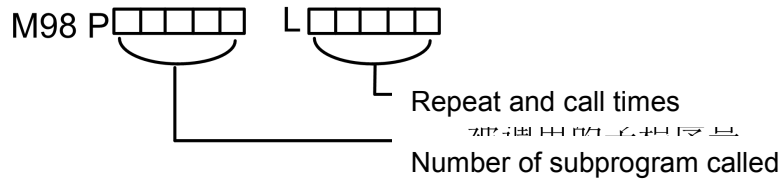
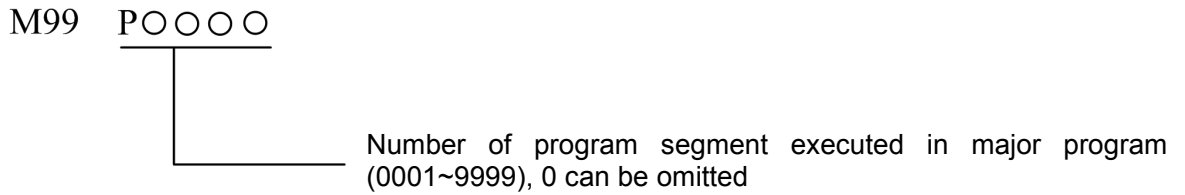

Fig. 5-2-4-1

5.2.5 Return from subprogram (M99)

Code format:



Function: (in subprogram) if other codes in present program segment are executed, they will return to program segment assigned by **P** in main program; if **P** is not inputted, it will return to main program to call the next program segment of Code M98 for continued execution. If Code M99 is completed in main program, it will have repeated execution of present program.

1. In auto running mode, if M99 is used at end of one program segment, it will return to beginning of program for auto execution when program reaches M99; if the following program is not executed, the workpiece amount will not be added.
2. If M99 is used at end of subprogram, it will return to main program when program reaches this segment and the next program in subprogram segment will be called for continued execution.

Chapter 6 S Code of Spindle Function

Through Code S and subsequent values, code signals are converted into analog signals sent to the machine for spindle control.

S is a modal value.

6.1 Analog Control of Spindle

If Bit Para N0: **1#2 SPT=0**, address S and subsequent values control the spindle speed by the use of analog voltage. See operating instructions for details.

Code format: S_

Description:

- 1、 One block can command a S code.
- 2、 Address S and subsequent data values specify the spindle speed directly, in revolutions / minute (r/min). For example, M3 S300 means the spindle runs at a speed of 300 r/min.
- 3、 When movement code and S code occur in the same block, they are executed simultaneously.
- 4、 The spindle speed is controlled through Code S and subsequent values.

6.2 Switching Value Control of Spindle

If Bit Para N0: **1#2 SPT=1**, address S and the subsequent two-digit switching value control the spindle speed.

In the case of switching value control, the system can provides 3 levels of spindle mechanical gear shifting. For the correspondence of S code to spindle speed and spindle speed levels the machine provides, please refer to the machine tool manufacturer's instructions for use.

Code format: S01 (S1);

S02 (S2);

S03 (S3);

Description:

At present, there are 8 gear shifting levels. The standard ladder graph shows 4 levels of gear shifting. If the program specifies a S code not stated above, the system will display “**miscellaneous function in execution**”.

6.3 Constant Surface Cutting Speed Control G96/G97

Code format:

Code of constant surface speed control G96 S_ surface speed (mm/min or inch/min)

Canceling code of constant surface speed control G97 S_ spindle speed (r/min)

Controlled axis code of constant surface speed control G96 P_ P1 X-axis; P2 Y-axis; P3 Z-axis; P4 4th axis

Function: S specifies a surface speed (relative speed between tool and workpiece). The spindle rotates in such a way to keep the surface cutting speed constant, disregarding the tool position.

Description:

1. G96 is a modal code. After it is commanded, the program enters constant-speed control mode. S is

surface speed.

2. G96 code must specify an axis, along which constant-speed control is used. G97 code cancels the G96 mode.

3. In order for constant surface cutting speed control, it is required to set the workpiece coordinate system taking the middle of rotating axis as zero point.

4. Linear speed = spindle speed × |X| × π ÷ 1000 (m/min)

Spindle speed: r/min

|X|: absolute value of absolute coordinate on X-axis (diameter value), in mm

π≈3.14

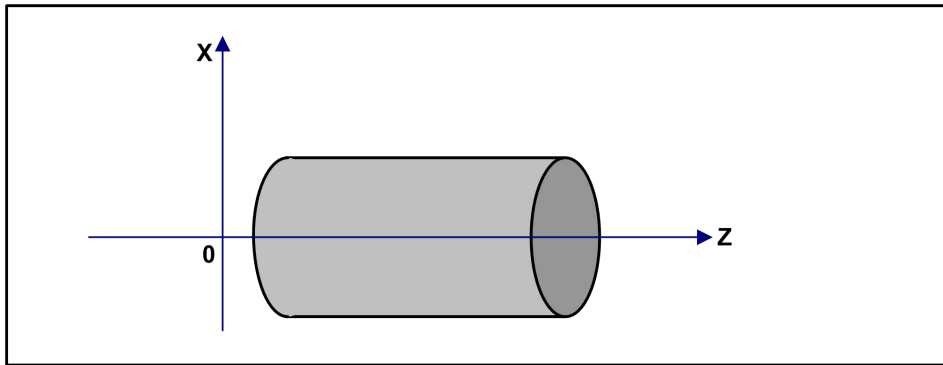

Fig.6-3-1 Workpiece Coordinate System under Constant Surface Cutting Speed Control

5. Under constant surface cutting speed control, a value higher than G50 S_ setting is suppressed at maximum spindle speed. If the maximum spindle speed is not set when the system is powered on, S in G96 code is regarded to be S=0 until M3 or M4 occurs in the program.

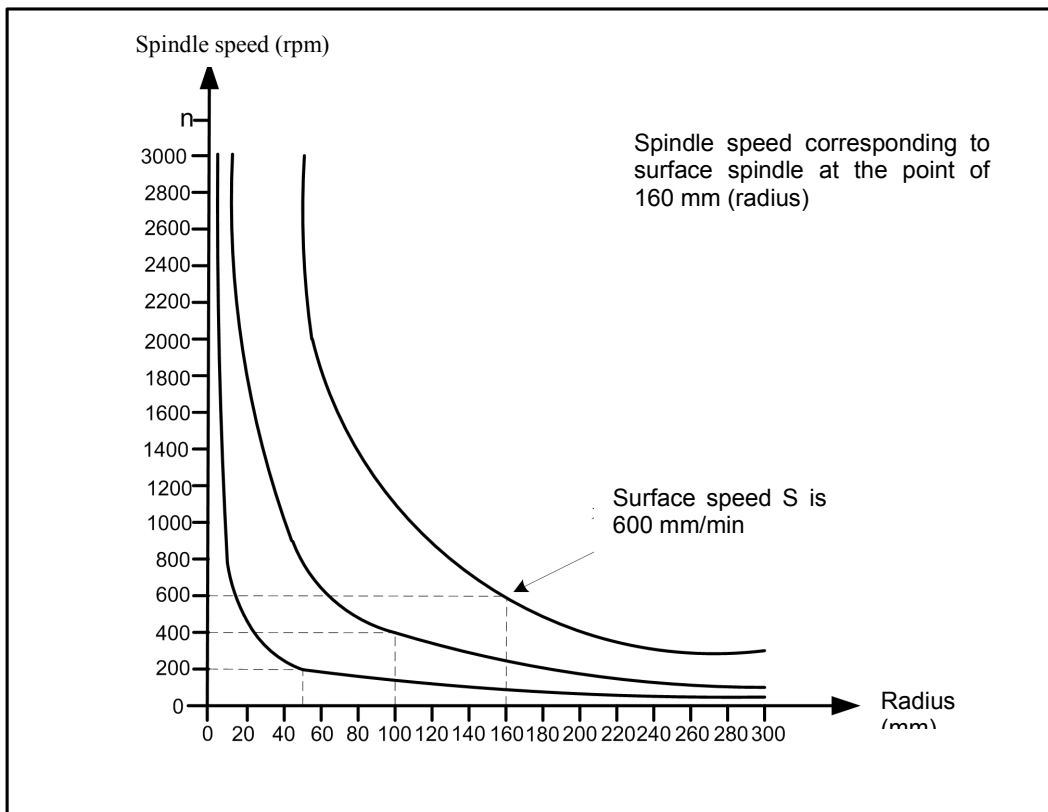

Fig.6-3-2 Relationship of Workpiece Radius and Spindle Speed with Surface Speed

6. The surface cutting speed is specified in G96 mode:

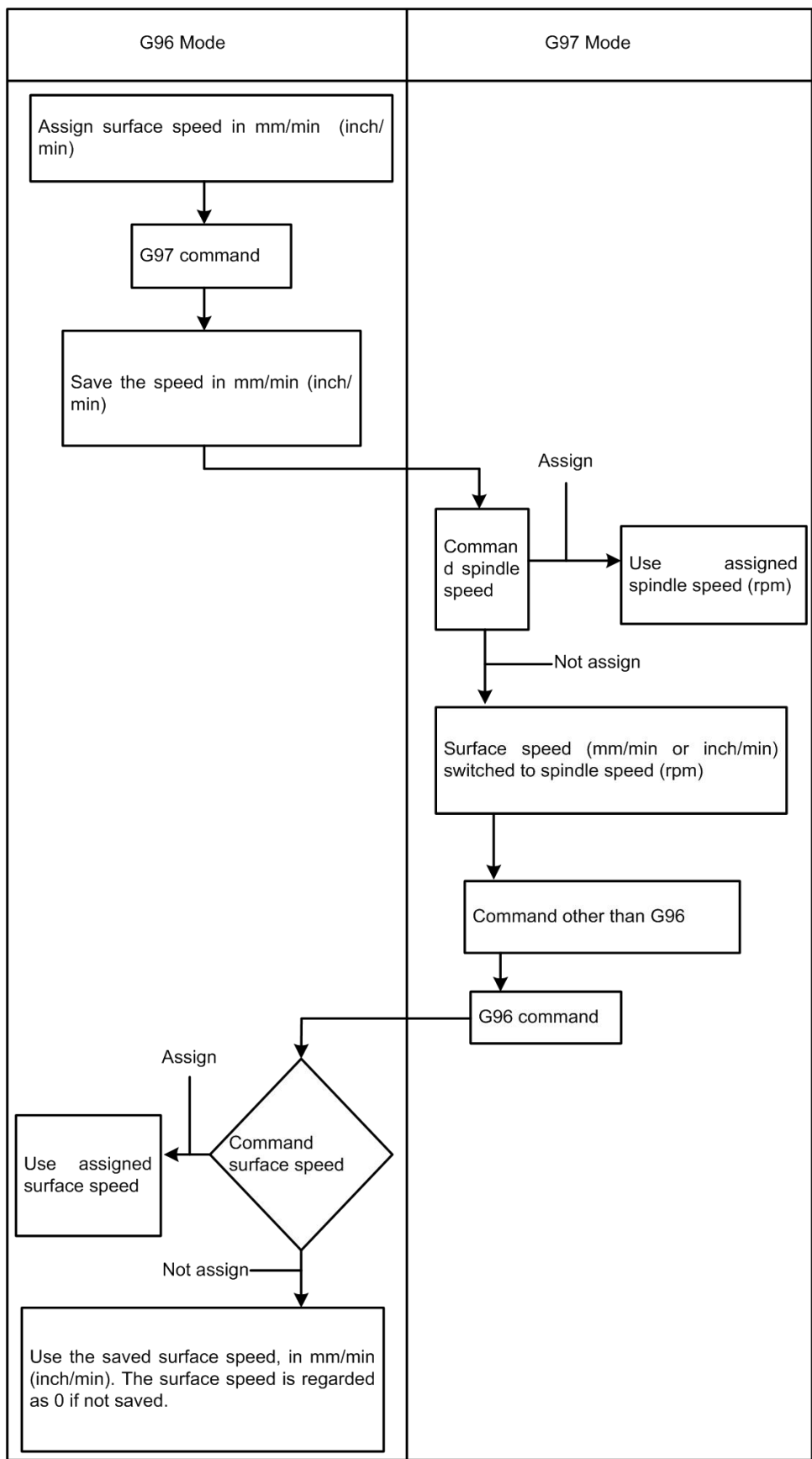

Fig.6-3-3

7. G96 related parameter setting: When G0 rapid positioning is set through Bit Para No.37#2, it is required to calculate the datum coordinate of G96 spindle speed (0: end point, 1: current point). G96 spindle speed suppression (0: before spindle magnification; 1: after spindle magnification) is set through Bit Para No.37#3; whether to use constant cycle speed control or not is set through Bit Para No.61#0.

Restriction:

1. The response of servo system is not considered in spindle speed variation, and constant surface cutting speed control is valid all the same during thread cutting. Thus, it is required to cancel the constant surface cutting speed through G97 before thread machining.
2. In the fast motion block specified by G00, constant surface speed control is realized with a surface speed calculated according to the end point of block not according to the instantaneous variation in tool position. Constant surface cutting speed is not used because fast motion does not involve cutting.
3. In the case of flexible tapping, rigid tapping, or deep-hole rigid tapping, it is required to cancel the constant surface cutting speed through G97 first. Otherwise, crowding or tap breaking will happen.

Chapter 7 F Code of Feed Function

The feed function controls the feed speed of tool as follows:

7.1 Fast Motion

Rapid positioning is realized through code (G00). The speed of rapid feed is set through Num Para P88~P92. Magnification can be adjusted as follows through magnification adjustment key on operation panel:



Fig.7-1-1 Rapid Feed Magnification Keys

Where, F0 is set through Num Para P93.

The rapid positioning (G0) acceleration can be set reasonably through number parameters P105~P123 according to the response characteristics of machine tool and motor.

Note: In G00 block, the feed speed F code is invalid even if it is specified. The system conducts positioning at G0 speed.

7.2 Cutting Speed

In linear interpolation (G01) or arc interpolation (G02, G03), the feed speed of tool is commanded through the value behind F code, in mm/min. The tool moves at cutting feed speed prepared in the program. The magnification of cutting feed speed is adjusted through feed magnification keys on machine operation panel (magnification adjustment range: 0% ~ 200%).

To prevent mechanical vibration, the tool speed can be controlled automatically at the beginning and end of tool movement. The acceleration can be set through number parameters P125~P128.

The maximum cutting speed is set through Num Para P96, and the minimum cutting speed through P97. If the cutting speed is higher than the maximum value, it is suppressed at the maximum value. If lower than the minimum value, it is suppressed at the minimum value.

When the system is energized, the cutting feed speed in automatic mode is set through Num Para P87.

The cutting speed can be specified in the following 2 modes:

- A). Feed per minute (G98): After F, the tool feed rate per minute is assigned.
- B). Feed per revolution (G99): After F, the tool feed rate per revolution of spindle is assigned.

7.2.1 Feed per Minute (G98)

Code format: G98 F_

Function: tool feed rate per minute, in mm/min or inch/min.

Description:

1. After G98 (feed per minute mode) is assigned, the tool feed rate per minute is immediately assigned through the value behind F.
2. As a modal code, G98 will be valid until the assignment of G99, once assigned. After power-on, the machine defaults to the feed per minute mode. The default of cutting feed speed is set

through Num Para P87.

3. It is allowed to control the speed of feed per minute through magnification adjustment keys on panel or through band switch. The magnification is 0 % ~ 200%.

7.2.2 Feed per revolution (G99)

Code format: G99 F_

Function: tool feed rate per revolution, in mm/r or inch/r.

Description:

1. The machine tool cannot use this function without a spindle encoder.
2. After the assignment of G99 (feed per revolution mode), the tool feed rate per revolution is set through the value behind F.
3. As a modal code, G99 will be valid until the assignment of G98, once assigned. During initialization, the default speed of feed per revolution is zero.
4. It is allowed to control the speed of feed per revolution through magnification adjustment keys on panel or through band switch. The magnification is 0 % ~ 200%.

Note 1: When the spindle speed is low, it is possible that the lower the spindle speed is, the more frequently the feed rate fluctuates.

Note 2: In G99 feed per revolution mode, the maximum speed of feed per revolution is F500. The system will give an alarm if the speed exceeds F500.

7.3 Linear Speed Control of Cutting

Generally, the cutting feed controls the speed in the direction of profile trajectory tangent and makes it reach the commanded value.

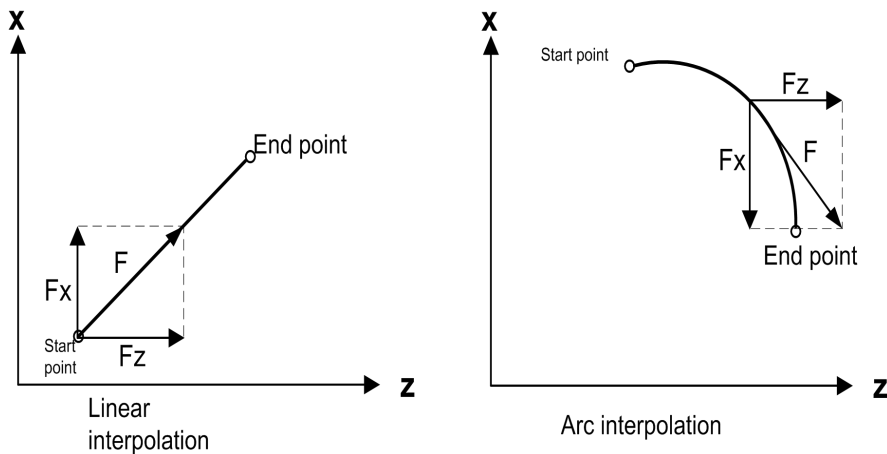

Fig.7-3-1

F: Speed in tangential direction
 F_x: Speed in X axis
 F_z: Speed in Z axis

$$F = \sqrt{F_x^2 + F_z^2}$$

7.4 Feed Speed Magnification Keys

The feed magnification in manual mode or in automatic mode can be adjusted through magnification adjustment keys on operation panel. The magnification can be 0 ~ 200% (10% for each gear, and 21

gears in total). In automatic mode, the system will stop feeding with the cutting magnification displayed at 0%, when magnification adjustment keys are set to zero. After magnification adjustment keys are adjusted, the program will continue running.

7.5 Automatic Speed Controlling

The system motor conducts speed controlling automatically at the beginning and end of movement, in order for steady start and stop. It also conducts speed controlling automatically when the movement speed varies, so that the speed can varies steadily. For this reason, speed controlling need not be considered in programming.

Rapid feed: before-interpolation speed controlling (0: linear; 1: S-type) after-interpolation speed controlling (0: linear; 1: exponential)

Cutting feed: before-interpolation speed controlling (0: linear; 1: S-type) after-interpolation speed controlling (0: linear; 1: exponential)

Manual feed: after-interpolation speed controlling (0: linear; 1: exponential)

(The common time constant used by each axis is set through parameters.)

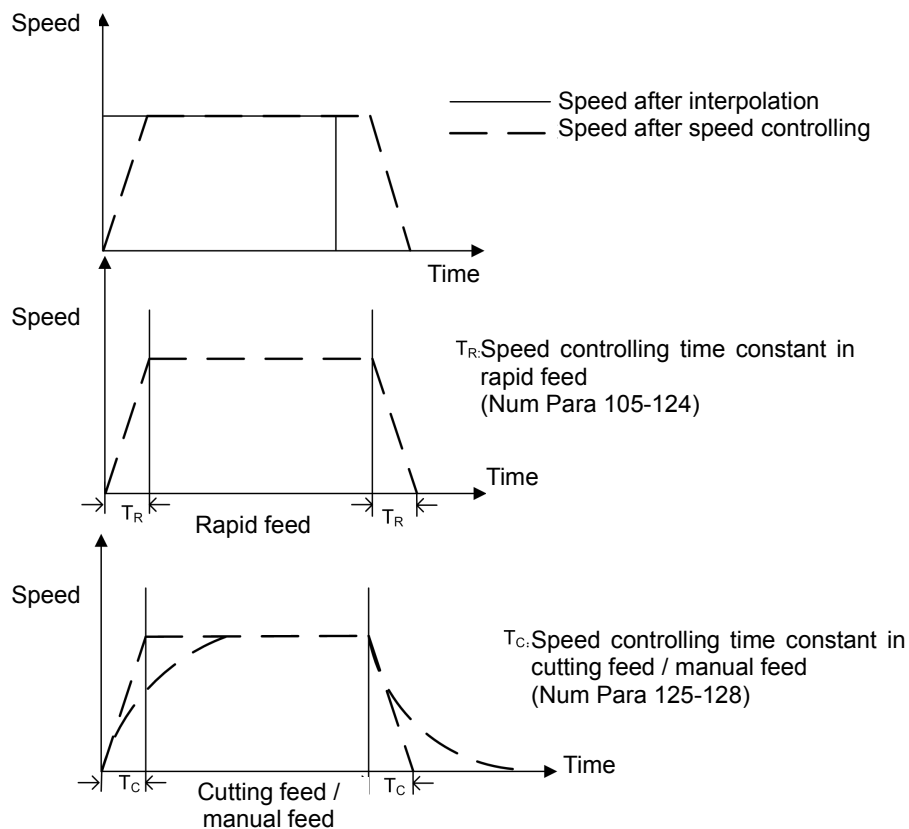

Fig.7-5-1

7.6 Speed Controlling at the Corner of Block

For example, if the only X-axis moves in last block and only Z-axis in next block, Z-axis speeds up during X slow-down. The tool trajectory is shown below:

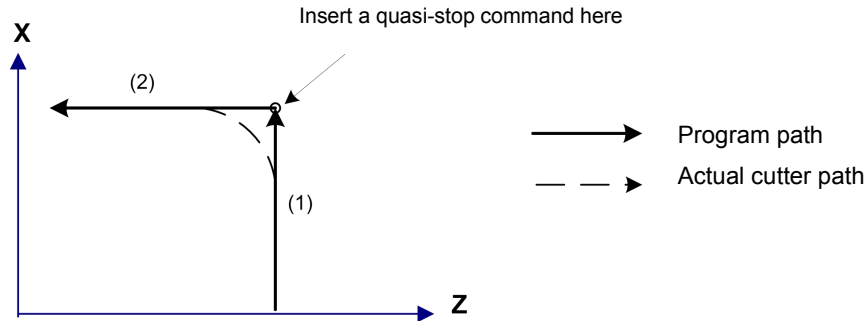

Fig.7-6-1

If a quasi-stop code is added, the tool moves according to the linear command (See the real time above). Otherwise, a higher cutting feed speed or a longer speed controlling time constant will cause a larger radius at the corner. In the case of an arc command, the arc radius of actual tool path is smaller than that given by program. In order to reduce the corner error, the speed controlling time constant should be minimized if allowed by the mechanical system.

Chapter 8 Tool Functions

8.1 Meaning of T Code Format

A value (maximum 4 digits) is assigned behind address T for selecting the tool on machine. When the movement code and T code are assigned in the same block, they are executed simultaneously.

In principle, it is not allowed to assign over two T codes in the same block. If it is set not to give an alarm when codes of the same group are assigned in the same block, the T code, which is behind, should be executed. For the allowed digits of address T and the machine movements corresponding to T codes, please see the machine manufacturer's instructions for use.

T codes have the following meanings:

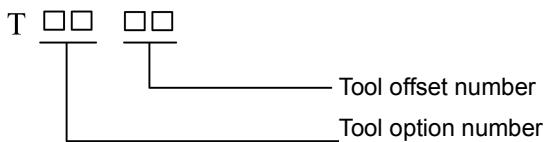

a) Tool selection

Tool selection is realized through the specified T code corresponding to tool number.

For the relationship of tool number selected with cutter, please refer to the machine manufacturer's manual.

b) Tool offset number

This is used for selecting the offset value corresponding to offset number. The offset value must be inputted through keyboard units. An offset number has 2 corresponding offset values, one on X-axis and other other on Z-axis. See *Display, modification, and setting of tool offset* in Operating Instructions for operation details.

Table 8-1-1

Offset No.	Offset Value	
	Offset Value of X Axis	Offset Value of Z Axis
01	0.040	0.020
02	0.060	0.030
03	0	0
..	.	.
..	.	.
..	.	.

If a T code is assigned and its offset number is not 00, the tool offset is valid.

If the offset number is 00, the tool offset function is canceled.

Setting range of offset value:

mm input: -9999.999 mm ~ 9999.999 mm

8.2 Tool Offset

An offset X, Z is specific to programming trajectory. A T code assigns the offset value corresponding

to offset number and is added to or removed from the end point of each block.

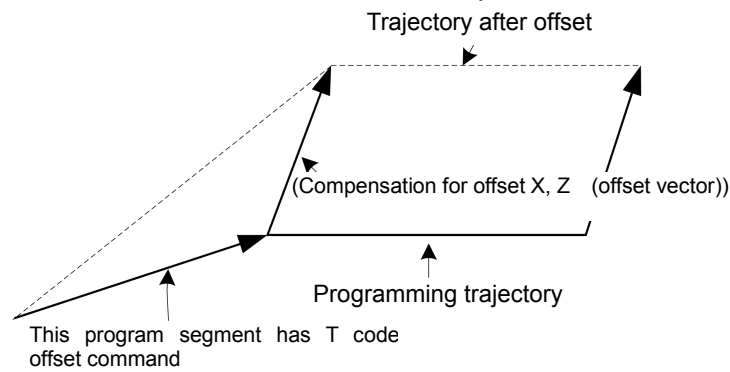

Fig.8-2-1

a) Offset vector

In the figure above, a vector with offset X, Z is called offset vector. Compensation functions as the offset vector.

b) Offset canceling

When the offset number of T code is 00, the offset is canceled. At the end of block canceled, the offset vector is zero.

```
N1 G01 U50.0 W100.0 T0202;
N2 W100.0;
N3 U0.0 W50.0 T0200;
```

Offset trajectory

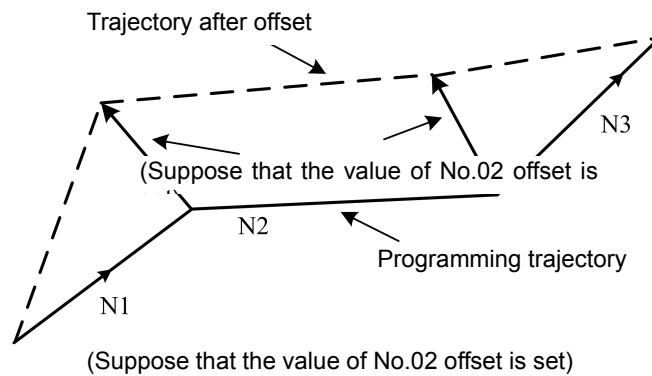

Fig.8-2-2

8.3 Programming Examples

Tool nose offset (Z, X)	Tool No.
Tool #1.....B (0.120, 0.200)	01
Tool #2.....C (-0.180, -0.050)	02

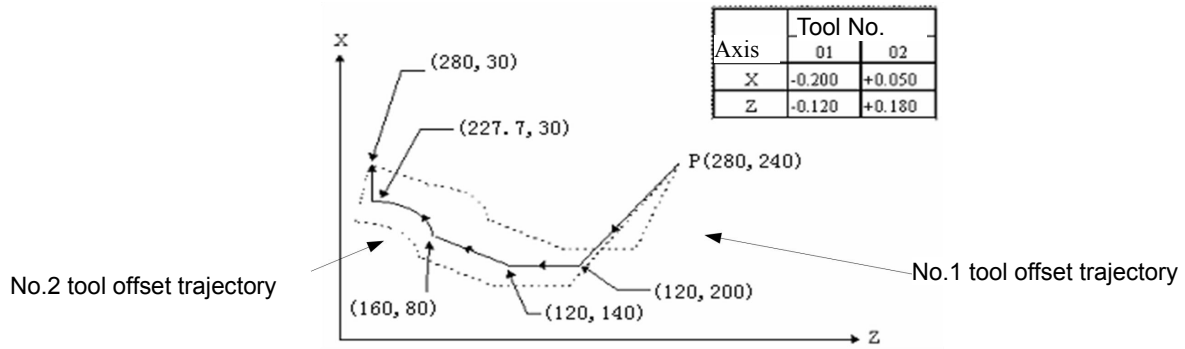

Fig.8-3-1 Tool Offset Compensation Example 2

(Programming example 1)

```
G00 X280.0 Z240.0;
G00 X120.0 Z200.0 T0101;
G01 Z140.0 F30;
X160.0 Z80.0;
G03 X227.7 Z30.0 R53.81;
G00 X280.0 T0100;
```

The nose trajectory of #1 tool is the same as this programming trajectory.

(Programming example 2)

Through the following modifications, the nose trajectory of #2 tool is the same as this programming trajectory.

```
T0101→T0202 and T0100→T0200
```

Part II Operating Instructions

Chapter 1 Operation Panel

1.1 Panel Division

GSK980TB3i series includes GSK980TB3i of horizontal structure and GSK980TB3i-V of vertical structure. The panel is divided into 4 areas: LCD (liquid crystal display) area, editing keyboard area, softkey functional area, and machine control area, as follows:

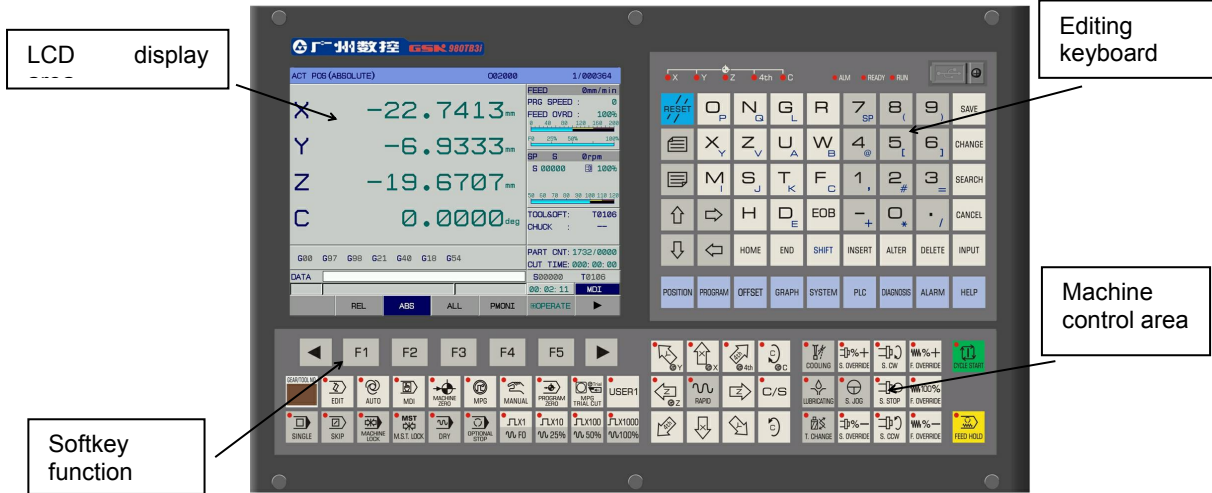

Fig.1-1-1 GSK980TB3i Panel

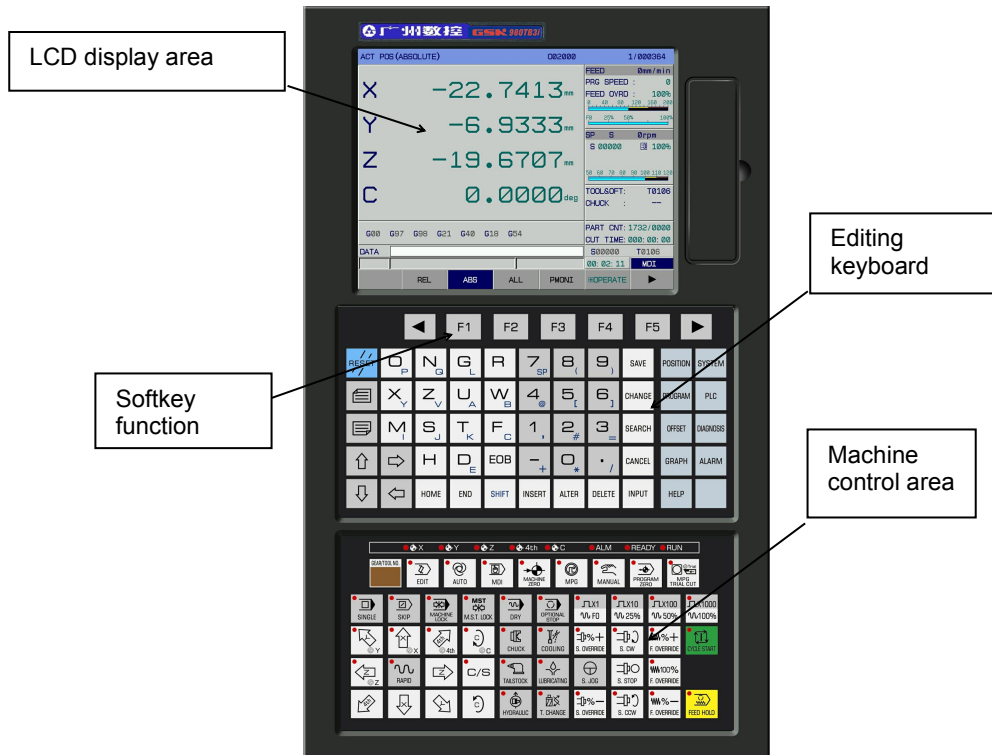

Fig.1-1-2 GSK980TB3i-V Panel

1.2 Description of Panel Functions

1.2.1 LCD (liquid crystal display) area

GSK 980TB3i and GSK980TB3i-V systems use 8.4-inch color LCD monitor with a resolution of 800×600.

1.2.2 Editing keyboard area

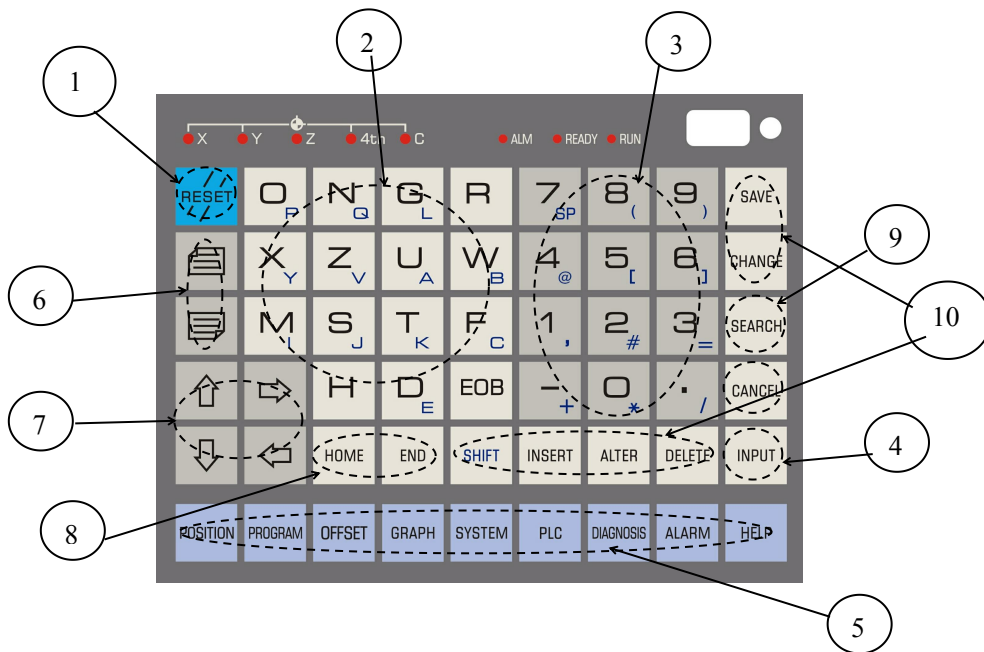

Fig.1-2-2-1 GSK980TB3i Editing Keyboard Area

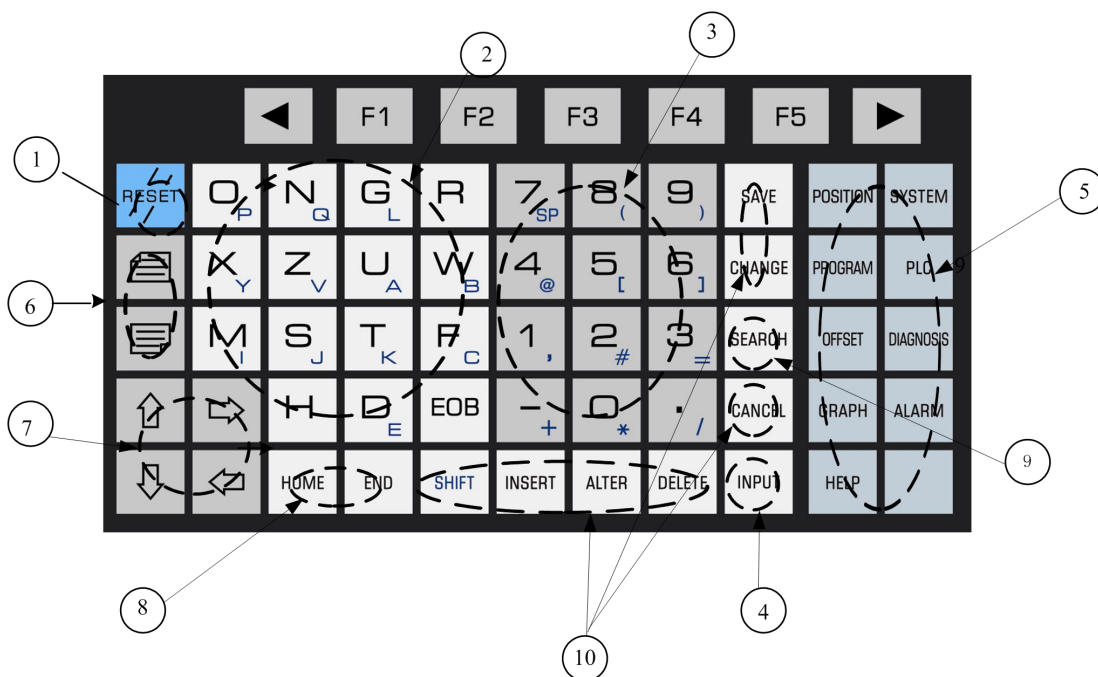

Fig.1-2-2-2 GSK980TB3i-V Editing Keyboard Area

The editing keyboard area is further divided into 10 zones by key function, and the instructions for use of each zone are given below:

S/N	Name	Function Description
1	RESET	System reset; feed and output stop
2	Address key	Start manual data input (MDI) of address
3	Number keys	Start MDI of numbers
4	ENTER	Input number, address, or data to the buffer zone; confirm the operation result
5	Screen Keys	Press any one of screen keys, and enter the corresponding interface display. (See Chapter 3 for details)
6	PgUp PgDn	Used for the page switching program page turning in the same display mode
7	CURSOR	Used for moving cursor
8	EDIT	Enable the cursor to move to the start or end of the program line or of the program
9	SEARCH	Used for searching data, address for further view or modification
10	EDIT	Used for inserting, modifying, or deleting a program or a field in program editing; use of composite keys

1.2.3 Introduction to screen keys

This system arranges 8 operation page display keys and 1 help page display key on operation panel, as follows:

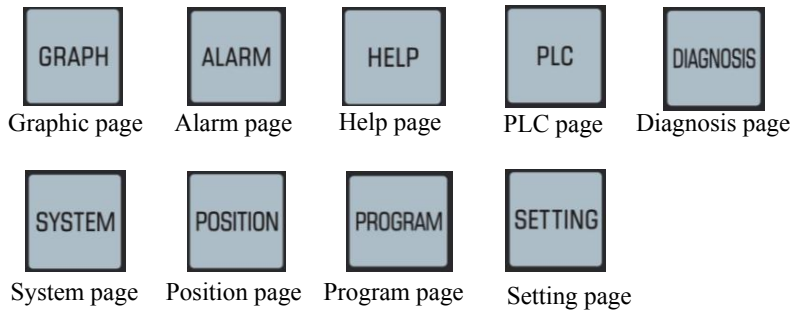

Name	Function Description	Remarks
Graph page	Enter graph page	Display graph parameter and graph page through corresponding softkey conversion; set the center, size, and scale of graph through parameters
Alarm page	Enter alarm page	View various alarm message pages through corresponding softkey conversion
Help page	Enter help page	View various help messages related to the system through corresponding softkey conversion
Ladder graph page	Enter ladder graph page	View the version information on PLC ladder graph and configuration of system I/O port through corresponding softkey conversion
Diagnosis page	Enter diagnosis page	View the I/O port signal state at each side of system through corresponding softkey conversion
System page	Enter system page	Display the CNC setting, parameters, pitch compensation, data, bus configuration, timed shutdown pages through corresponding softkey conversion
Position page	Enter position page	Display the relative coordinate, absolute coordinate, comprehensive coordinate, program monitor pages through corresponding softkey conversion
Program page	Enter program page	Display the program, MDI, catalog display pages through corresponding softkey conversion; it is allowed to view many pages of program name through PgUp PgDn on catalog interface
Offset page	Enter offset page	Display 3 interfaces (offset, workpiece coordinate, macro-variable) through corresponding softkey conversion

Note: Through the setting of bit parameters NO:25#0 ~ 25#7 and NO:26#6 ~ 26#7, the above softkey conversion can be realized by continuously pressing corresponding function keys. For details of each page, please refer to Chapter 3 of this operation manual.

1.2.4 Machine control area

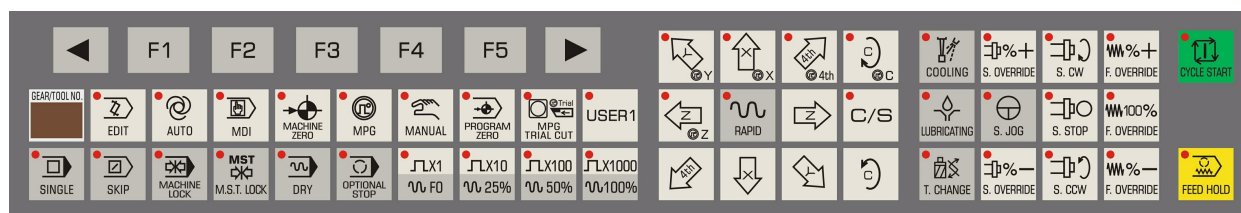

Fig.1-2-4-1 GSK980TB3i Machine Control Area

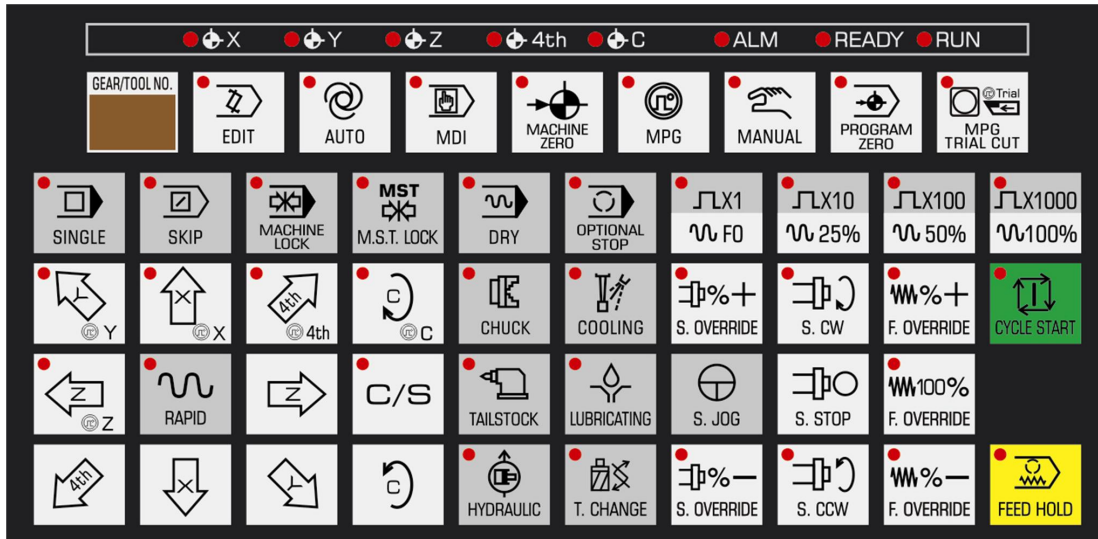





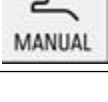









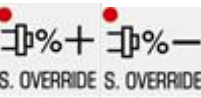

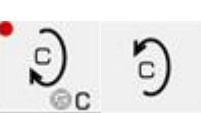

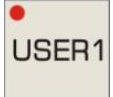



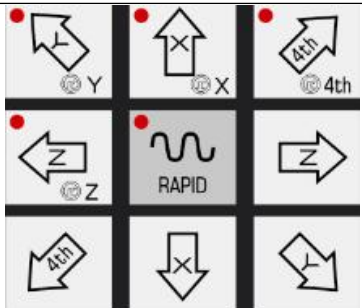



Fig.1-2-4-2 GSK980TB3i-V Machine Control Area

GSK980TB3i and GSK980TB3i-V have the use and function definition of basic keys in machine control area in common.

Keys	Designation	Explanation	Note and Operation Instructions
	Edit mode key	To enter edit mode	Auto mode, MDI mode, switching to Edit mode in operation process; it decelerates and stops after the system finishes operating the current program segment
	Auto mode key	To enter auto mode	In this mode, internal storage program inside system is selected
	MDI mode key	To enter MDI mode	Switching to MDI mode in Auto mode, system decelerates and stops after finishing operating the current program segment
	Machine zero return mode key	To enter machine zero return mode	Switching to Machine zero return mode in Auto mode. System will decelerate and stop immediately
	Program zero return mode key	To enter program zero return mode	Switching to Program zero return mode in Auto mode. System will decelerate and stop immediately
	Manual mode key	To enter manual mode	Switching to Manual Mode in Auto mode. System will decelerate and stop immediately
	MPG mode key	To enter MPG mode	Switching to MPG mode in Auto mode. System will decelerate and stop immediately
	Block skip key	If the program segment marked with “/” skips; the indicator lights up and the program skips when it is started	Auto mode and input mode
	Single segment key	Single program segment/continuous operation stats switching; it means single segment operation if indicator lamp is on	Auto mode and input mode
	Idle operation switch	The indicator lamp is on if idle operation is valid	Auto mode and input mode
	Optional ON/OFF key	Whether the operation is stopped if the program contains “M01”	Auto mode and input mode

Keys	Designation	Explanation	Remarks and Operation Instructions
	Auxiliary function switch	When auxiliary function is enabled, indicator lamp will be on and M, S, T and function output become invalid	Auto mode and input mode
	Machine lock switch	The indicator lamp is on and axis output is invalid if machine lock is unlocked	Auto mode, input mode, machine zero return, hand wheel mode and manual mode
	Lubrication switch key	Machine lubrication ON/OFF	Any mode
	Cooling fluid switch key	Cooling fluid ON/OFF	Any mode
	Spindle control key	Spindle positive rotation Spindle rotation stopping Single negative rotation	Hand wheel mode and manual mode
	Spindle rate key	Spindle speed adjustment (spindle speed analog control valid)	Any mode
	Spindle inching switch	Spindle inching status ON/OFF	Manual mode, hand wheel mode and single step mode
	C/S axis clockwise and anticlockwise rotation key	C/S axis clockwise and anticlockwise rotation	Valid when the spindle is analog amount control mode in manual mode
	Tool change switch key	Tool change switch	Valid in manual pulse mode, manual mode and single step mode
	User self-definition key	User self-definition	

Keys	Designation	Explanation	Remarks and Operation Instructions
	C/S axis switching	Switching spindle speed/position control	Machine zero return, program zero return, hand wheel mode, manual mode and single step mode
	Fast movement key	Fast movement ON/OFF	Manual mode
	Fast rate, manual single step, hand wheel rate option key	Fast rate, manual single step, hand wheel rate option key	Automatic mode, input mode, machine zero return, hand wheel mode and manual mode
	Manual feeding key	Axis X, Y, Z and C positive/negative movement in manual, single step operation mode; hand wheel option axis is along the positive direction of axis	Machine zero return, manual mode, hand wheel mode
	Feeding maintain key	The system will stop automatic operating by pressing this key	Automatic mode and input mode
	Circulating startup key	The system will start automatic operating by pressing this key	Automatic mode and input mode

Note 1: When there are more than 1 “/” at the beginning of a block, the system will skip over that block even if the hop-by-hop function is not opened.

Note 2: In manual mode, the manual speed ratio is adjusted through feed switch when the fast motion key is not pressed.

Note 3: In following instructions, keys inside < > are panel keys; keys inside [] are softkeys below screen; [] is the interface corresponding to current softkey; [] means the menu has subordinate menus.

Note 4: There is a user defined key USER1.

Chapter 2 System Power-On, Shutdown, and Safe Operation

2.1 System Power-On

Before GSK980TB3i CNC system power-on, it is required to confirm that:

1. The machine tool is normal.
2. The supply voltage meets the requirements.
3. Connections are proper and firm.

If the system self-inspection is normal, initialization is followed by present POS (relative coordinate) page.

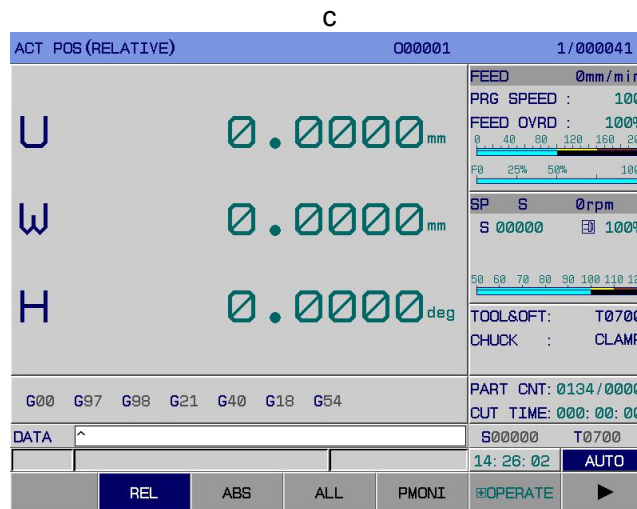

Fig.2-1-1

2.2 Shutdown

Before shutdown, it is required to confirm that:

1. The X and Z axes of CNC stay in a stop state;
2. Miscellaneous functions (such as spindle and water pump) are closed;
3. CNC is switched off first, and machine tool second.

Before power cutoff, it is required to confirm that:

1. The LED indicator circulation start-up on operation panel stays in a stop state;
2. All movable components of CNC machine stay in a stop state;
3. The system is shut down by pressing POWER OFF.

Emergency power-off

During operation, the machine tool can be switched off immediately in emergency, in case of accident. However, it should be noted that the system coordinate may deviate from actual position after power-off. Thus, zero returning and tool setting are required.

Note: For machine tool power-off, please refer to the manufacturer's instructions for use of machine tool.

2.3 Safe Operations

2.3.1 Reset



The system stays in the reset state after  is pressed:

1. All axis motions stop.
2. M function stops.
3. Modify the bit parameters NO:35#1 ~ NO:35#5, NO:35#7 and NO:36#0 ~ 36#7 to set whether to keep G code or not after reset.
4. Modify the Bit Para NO:34#7 to set whether to F, H, and D codes or not after reset.
5. Modify the Bit Para NO:28#7 to set whether to delete the program or not after reset in MDI mode.
6. Modify the Bit Para NO:10#3 to set whether to cancel the relative coordinate system or not after reset.
7. Modify the Bit Para NO:10#7 to set whether the cursor returns to program start or not after reset in non-editing mode.
8. Modify the Bit Para NO:52#7 to set whether to clear local variables #1 ~ #50 of macro-program or not after reset.
9. Modify the Bit Para NO:52#6 to set whether to clear public variables #100 ~ #199 of macro-program or not after reset.
10. It can be used in the case of system output exception or motion exception of coordinate axis.

2.3.2 Emergency stop

During machine tool operation, press EMERGENCY STOP and the system will enter the emergency stop state. Immediately, the machine tool stops moving. This state is removed after EMERGENCY STOP is released. (In spite of different manufacturers, this button will automatically bounce up generally after left rotation.)

Note 1: Before the release of emergency stop state, it is required to confirm the fault cause has been troubleshot.

Note 2: After the release of emergency stop state, it is required to conduct zero returning again so as to ensure the correctness of coordinate position.

In most cases, the emergency stop signal is a normally-closed contact signal. When the contact is disconnected, the system goes into the emergency stop state immediately and the machine tool stops urgently. The circuit of emergency stop signal is connected as follows:

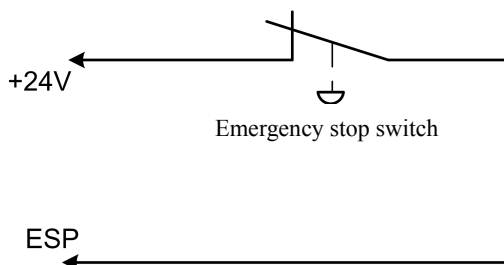

Fig.2-3-2-1



2.3.3 Feed hold



Machine operation can be paused by pressing  (Feed Hold). It should be noted that, during cyclic code operation, pause follows the present code operation.

2.4 Circulation Start-up and Feed Hold



On control panel,  (Circulation Start-up) and  (Feed Hold) are used for starting and pausing the program in automatic mode and MDI mode. Modify PLC addresses **K5.1** and **K5.3** to set whether to use external start and pause or not.

Note 1: Switched between auto and MDI modes. Circulation start-up is valid before the execution of current block ends. Feed hold is invalid after Feed Hold is pressed.

Note 2: Switched from auto and MDI modes to editing mode. Circulation start-up is invalid before the execution of current block ends. Feed hold is invalid after Feed Hold is pressed.

Note 3: Switched from auto and MDI modes to zero returning, single-step, manual, and manual pulse modes. Feed hold is invalid after Feed Hold is pressed.

Note 4: If circulation start-up is valid and the system is switched between auto and MDI modes or switched to editing mode, the feed hold function is invalid when Feed Hold is pressed before the execution of current block ends.

2.5 Over-travel Protection

To prevent a machine tool from being damaged due to **X-axis** and **Z-axis** over-travel, there must be over-travel protection measures.

2.5.1 Hardware over-travel protection

Travel limit switches are mounted at the maximum strokes of **X-axis** and **Z-axis** in positive & negative directions. In the case of over-travel, after a limit switch is touched, the operating axis decelerates to a stop state and the system gives an over-travel alarm.

Specification:

Over-travel in automatic operation

In automatic operation mode, when the tool touches a limit switch on some axis, all axis motions decelerate to a stop state and the system gives an over-travel alarm. The program stops in the over-travel block.

Over-travel in manual operation

In manual operation mode, all axis motions decelerate to a stop state as long as any axis touches the limit switch.

2.5.2 Software over-travel protection

The software stroke is set through parameters **P66~P75**, taking the coordinate of machine tool as the reference value. If a moving axis goes beyond the setting of software limiting parameters, the system will give an over-travel alarm. Whether to conduct stroke detection or not (0: No; 1: Yes) after power-on before manual returning to the reference point is set through Bit Para **N0:11#6**. It is set through Bit Para **N0:11#7** to give an alarm (0: before or 1: after) over-travel. In the case of an

over-travel alarm, the alarm is released if the counter moving axis in <manual> mode goes beyond the over-travel range.

2.5.3 Release of over-travel alarm

Method to release a hard over-travel alarm: In manual or manual pulse mode, move the axis out in the reverse direction (in the case of positive over-travel, move it out in negative direction; in the case of negative over-travel, move it out in positive direction).

Chapter 3 Modification & Setting of Interface Display and Data

3.1 Position Display

3.1.1 Four modes of display on position page



Press  and enter the position page, which has five interfaces: [relative coordinate], [absolute coordinate], [comprehensive], [program monitor], and [operation]. They can be viewed through corresponding softkeys, as follows:

1) Relative coordinate: Press [relative coordinate] and display the the position of current tool inside relative coordinate system. (See Fig.3-1-1-1)

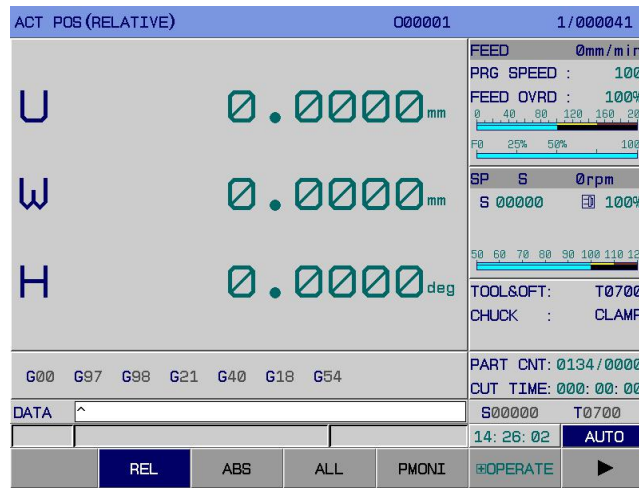

Fig.3-1-1-1

2) Absolute coordinate: Press the softkey [absolute coordinate] to display the position of current tool inside absolute coordinate system. (See Fig.3-1-1-2)

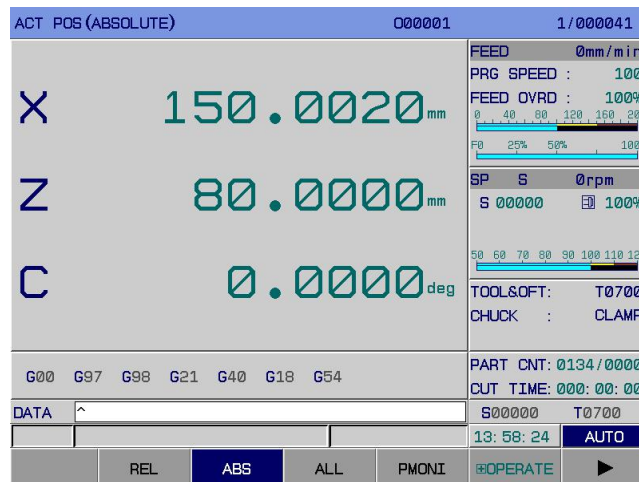

Fig.3-1-1-2

3) Comprehensive: Press [comprehensive] to go into the interface and display:

(A) Position inside relative coordinate system;

- (B) Position inside absolute coordinate system;
- (C) Position inside machine coordinate system;
- (D) Offset (displacement) in manual pulse interruption;
- (E) Velocity component;
- (F) Surplus shift (**displayed in automatic MDI mode only**).

The display page is shown below (See Fig.3-1-1-3):

ACTUAL POSITION			00001	1/000041
(RELATIVE)		(ABSOLUTE)		(MACHINE)
U	0.0000 mm	X	150.0020 mm	X 0.0000 mm
W	0.0000 mm	Z	80.0000 mm	Z 0.0000 mm
H	0.0000 deg	C	0.0000 deg	C 0.0000 deg
(HANDLE INTR)		(SUBSPEED)		(REM DIST)
X	0.0000 mm	X	0.0000 mm/min	X 0.0000 mm
Z	0.0000 mm	Z	0.0000 mm/min	Z 0.0000 mm
C	0.0000 deg	C	0.0000 deg/min	C 0.0000 deg
DATA	^			S00000 T0700
				14:27:08 AUTO
	REL	ABS	ALL	PMONI
				OPERATE ▶

Fig.3-1-1-3

4) On [comprehensive] interface, press [operation] to display: (See Fig.3-1-1-4)

ACTUAL POSITION			00001	1/000041
(RELATIVE)		(ABSOLUTE)		(MACHINE)
U	0.0000 mm	X	150.0020 mm	X 0.0000 mm
W	0.0000 mm	Z	80.0000 mm	Z 0.0000 mm
H	0.0000 deg	C	0.0000 deg	C 0.0000 deg
(HANDLE INTR)		(SUBSPEED)		(REM DIST)
X	0.0000 mm	X	0.0000 mm/min	X 0.0000 mm
Z	0.0000 mm	Z	0.0000 mm/min	Z 0.0000 mm
C	0.0000 deg	C	0.0000 deg/min	C 0.0000 deg
DATA	^			S00000 T0700
				14:27:35 AUTO
		INC CAN	INTR CAN	INTR ON
				RETURN

Fig.3-1-1-4

5) Program monitoring mode

Press [program monitoring] to go into [program monitoring] interface. On this interface, the absolute coordinate, relative coordinate, surplus shift of current position and the modal information, operating block of current operating program can be displayed simultaneously. (See Fig.3-1-1-5)

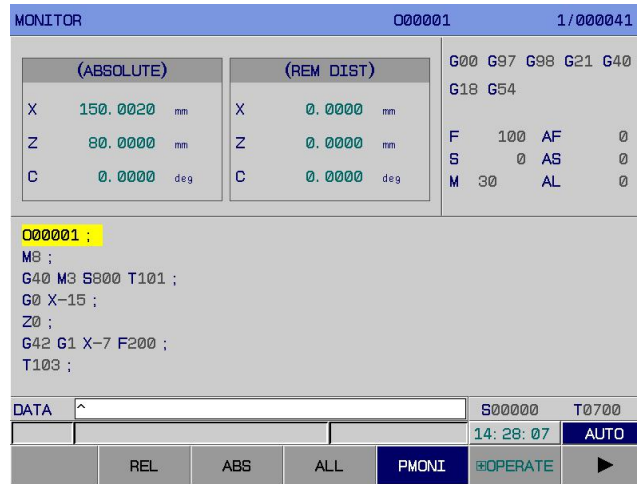

Fig.3-1-1-5

Note 1: Whether to display the model or not on program monitoring interface can be set through parameter NO.: 23#6. When BIT6=0, the interface does not display modal code but display the coordinate of machine tool at original position.

Note 2: In 6 modes (<program zero returning>, <single-step>, <manual>, <manual pulse>, <machine zero returning>, <edit>), a relative coordinate system is displayed at center the top of the page; in 2 modes (<automatic> and <MDI>), the surplus shift at center the top of the page.

3.1.2 Display of processing time, number of parts, programming speed, magnification, actual velocity

In <position> display mode, the [absolute coordinate] and [relative coordinate] interfaces can display the programming speed, actual speed, feed magnification, rapid magnification, G function code, tool offset, number of work pieces, cutting time, spindle speed magnification, spindle speed, chuck state, machining tool, etc. as shown in Fig.3-1-2-1:

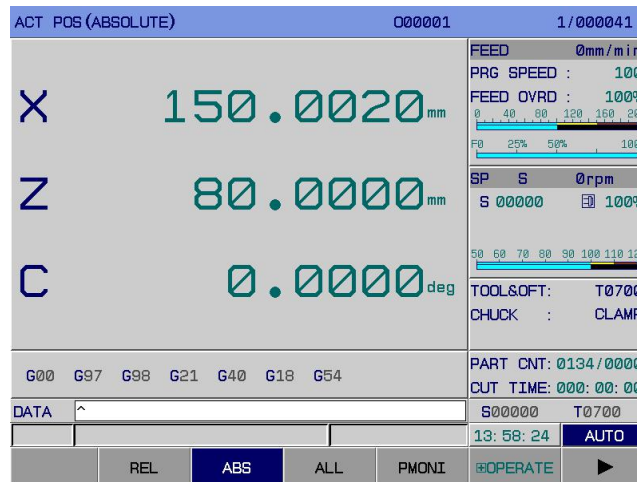

Fig.3-1-2-1

Their concrete meanings are given below:

Speed: actual processing speed after magnification.

Programming speed: speed designated by F code in the program.

Feed magnification: magnification selected by feed magnification switch.

Rapid magnification: system default magnification controlled by the panel, or magnification selected by the feed magnification band switch

G function code: value of G code that is being executed.

number of work pieces: “0002/0000” or “0002” is the number of machined parts; “0000” is the aggregate number of parts to be machined. When the program executes M30 or M02 in automatic mode, the number of machined parts is increased by 1; this number does not change in other modes. When the number of machined parts is greater than or equal to the aggregate number of parts to be machined, the system sends a signal F62#7=1. How to use this signal is defined by the machine tool manufacturer.

cutting time: When automatic operation is initiated, timing starts. It is expressed in hour, minute, second.



S00000: command speed. Press  below relative coordinate or absolute coordinate page, and the cursor will be located at “S 00000” (spindle speed). At this time, you can modify S value (range: 0 ~ setting of P258).

Tool offset: tool number designated by T code in the program.

Note: number of work pieces power failure memory.

number of work pieces and cutting time clearing methods:

1) Switch to the relative coordinate or absolute coordinate interface.



2) Press  and the cursor will be located at “number of work pieces” column. Then, you can



input a value in the MDI mode. Press  and the number of machined parts will be cleared.

3) Switch to cutting time using up and down keys.



4) Press  : cutting time will be cleared.

Note 1: There must be an encoder mounted on spindle to display the actual speed of spindle.

Note 2: actual speed = F value of programming speed × magnification. For G00, the operating speed of each axis is set through parameters P88 ~ P92 and may be adjusted through rapid magnification; the maximum speed is set through parameter P86.

Note 3: programming speed of feed per revolution: displayed during the execution of block involving feed per revolution. feed per revolution.

3.1.3 Relative coordinate clearing and halving

The relative coordinate position is cleared as follows:

1) Enter any interface displaying a relative coordinate (as shown in Fig.3-1-3-1);

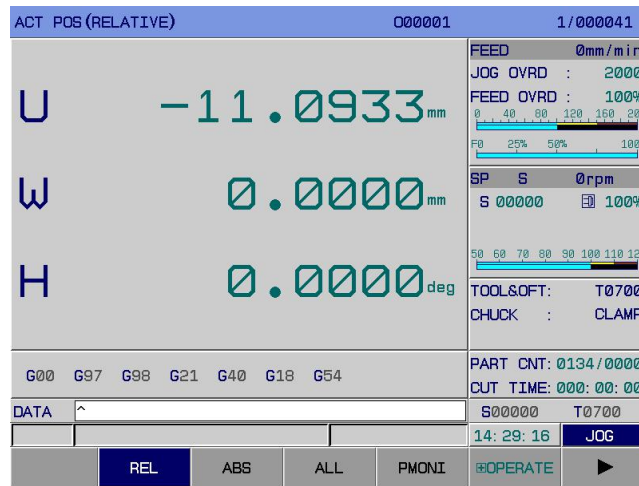
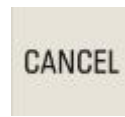
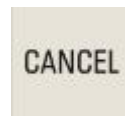

Fig.3-1-3-1



2) **Clearing operation:** Press “X” or “U” key, and U on interface will flicker. Press , and the relative coordinate value in X direction will be cleared (as shown in Fig.3-1-3-2);

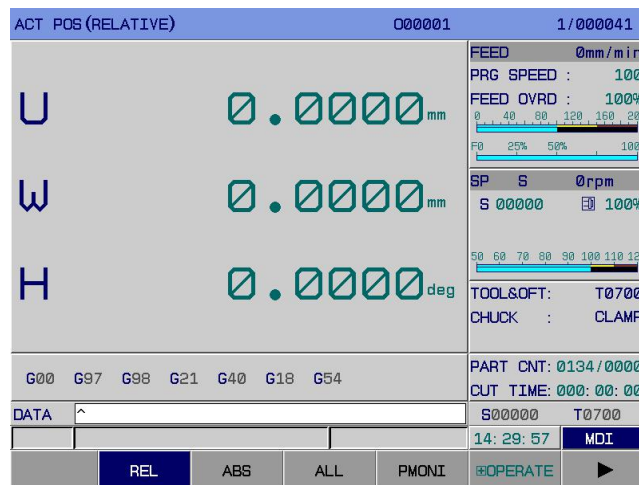



Fig.3-1-3-2



3) **Halving operation:** Press “X” or “U” key, and U on interface will flicker. Press , and the relative coordinate value in X direction will be halved (i.e., the relative coordinate value is divided by 2);

4) **Coordinate setting:** Press “X” or “U” key, and U on interface will flicker. Input the data to be set,



and confirm it by pressing . Then, the data will be inputted to the coordinate system.

5) **Z-axis** clearing method is the same.

3.1.4 Bus monitoring page display



When the system uses Ethernet bus communication mode, press 

to enter the position page display. Press [▶] to enter the [monitor] interface. This interface can display the current machine coordinate, multi-turn position, single-turn position, raster position, motor speed, motor load (% , percentage of rated load) simultaneously. It is convenient for machine debugging and real-time monitoring of current operating state of servo. (See Fig.3-1-5)

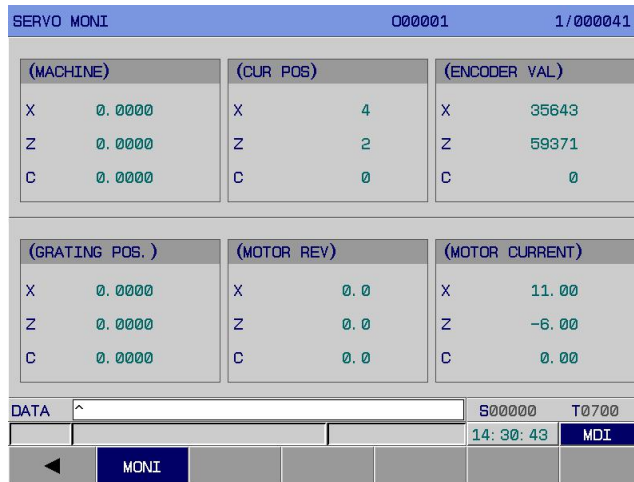

Fig.3-1-4

3.2 Program Display

PROGRAM

Press

on panel to enter the program page display. There are 3 sub interfaces: [▣program], [MDI] and [catalog], which can be viewed and modified through corresponding softkeys, as shown in Fig.3-2-1. Details are given below:

1) Program display

Press [▣program] to enter the program display interface. This interface displays the program on the page where the block being executed in memory is (as shown in Fig.3-2-1).



Fig.3-2-1

Press [▣program] again to enter the editing and modification page of program (as shown in Fig.3-2-2):

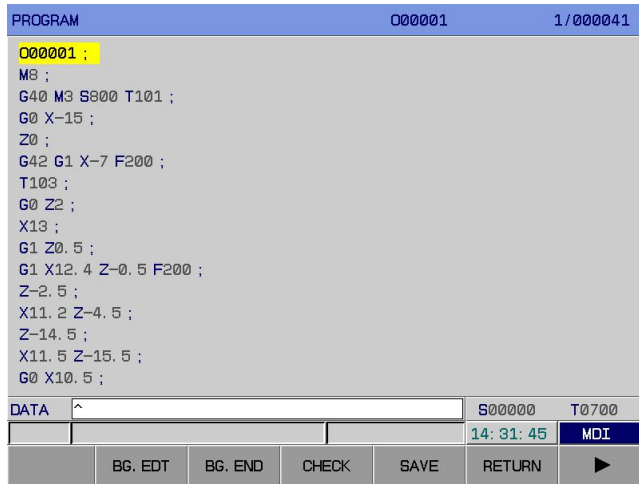

Fig.3-2-2

Press [▶] to enter the next page



Press [▶] to enter the next page



Press [◀] to enter the next page



In automatic mode, press [debugging] to check current program grammar. If there is a grammar mistake, the system will give an alarm.

[B. edit] and [B. End] can only be operated in automatic mode (back-end editing function). The functions of [B.editing] are exactly the same as program editing in <edit> mode. See Chapter 10 *Program Editing Operations* of Operating Instructions. After editing, press [B. End] to save or press [back] to exit the editing interface.

Note: For the moment, [debugging] does not support (back-end editing) program grammar checking.

2) MDI input display

Press [MDI] to enter the MDI display interface. In input MDI mode, it is allowed to prepare and execute the multi-block program in the same format as editing program. **MDI** operation is applicable to simple testing program operations (See Fig.3-2-3).

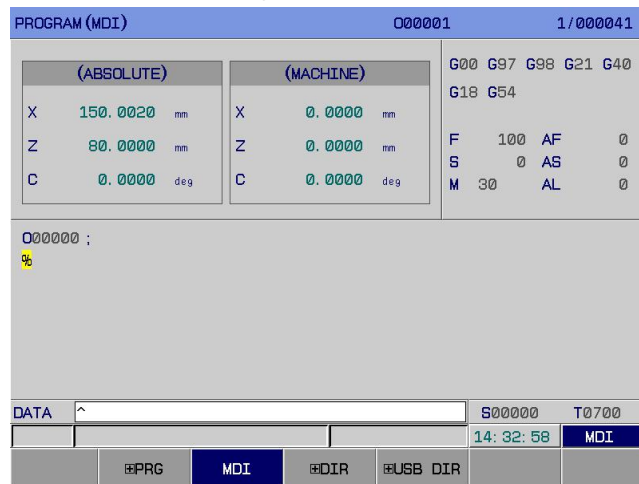

Fig.3-2-3

3) Program catalog display

Press [catalog] to enter the program (system catalog) display interface. The display content is shown

below (See Fig.3-2-4):

- (a) Program quantity: number of programs stored (including subprogram) / maximum number of programs that can be stored.
- (b) Storage capacity: storage capacity occupied / total storage capacity.
- (c) Program catalog table: display the number of program stored in sequence.
- (d) Preview the program where the cursor is now.

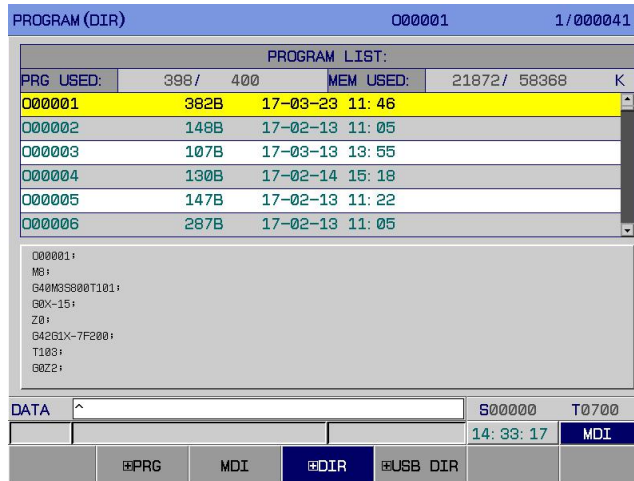
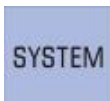

Fig.3-2-4

Explanation: Display the number of each program in memory through PgUp PgDn. A program name that exceeds 6 places or that does not meet specifications cannot be previewed.

3.3 System Display



Press **SYSTEM** to enter the system page. This page contains 6 sub- interfaces: [**SYSTEM**CNC setting], [**SYSTEM**parameter], [pitch compensation], [**SYSTEM**data], [**SYSTEM**bus configuration], and [**SYSTEM**timed shutdown], which can be switched through corresponding softkeys.

3.3.1 CNC setting page

1. Page access

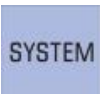

Press **SYSTEM** to enter the setting display interface. On this interface, it is allowed to view or modify settings through corresponding softkeys, as follows (See Fig.3-3-1):

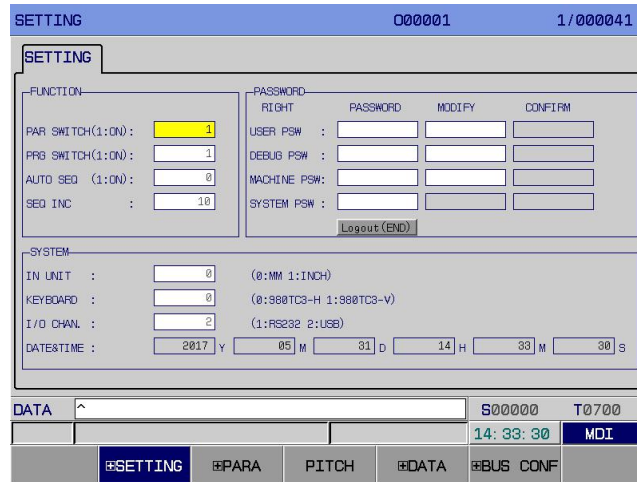

Fig.3-3-1

2. [CNC setting] interface operating instructions

Press [CNC setting] to enter the setting interface shown in Fig.3-3-1. It is allowed to view and modify parameters. Concrete operation methods and steps are given below:

- (a) Enter <MDI> operation mode;
- (b) Move cursor through up and down keys to the item to be modified;
- (c) Type 0 or 1 according to the following instructions;

1) Parameter switch

0: Turn off parameter switch 1: Turn on parameter switch

When parameter switch is set to “0”, it is forbidden to modify or set system parameters.

2) Program switch

0: Turn off program switch 1: Turn on program switch

When program switch is set to “0”, it is forbidden to edit the program.

3) Keyboard selection

0: 980TB3i-H 1: 980TB3i-V

Note: In any mode, it is allowed to modify keyboard choice by pressing EMERGENCY STOP.

4) Input unit

Set the input unit of program to be metric system or British system

0: Metric 1: British

5) I/O channel

1: RS232 2: USB

6) Auto sequence number

0: In editing mode, the system will not automatically insert the sequence number after a program is typed using keyboard.

1: In editing mode, the system will automatically insert the sequence number after a program is typed using keyboard. The sequence number increment between different blocks is set through Num Para P210.

7) Sequence number increment

Set the increment for automatic insertion of sequence number, within the range 0~1000.

8) Data and time

The user can set the system date and time at this place.



(d) Press INPUT to input something.

3.3.1.1 Setting and modification of password and permission

In order to prevent the machine program or **CNC** parameters from being modified with malice, **GSK980TB3i** system offers the permission setting function. Its password is divided into 5 levels: Grade 1 (end user level), Grade 2 (system debugging level), Grade 3 (machine manufacturer level), Grade 4 (system manufacturer level), Grade 5 (machining operation level). After turn-on and power-on, the system is at the minimum level in default.

Grade 1: It is allowed to modify some of CNC state parameters and number parameters.

Grade 2: It is allowed to modify **CNC** state parameters, number parameter, offset data, and pitch compensation.

Grade 3 and Grade 4: It is allowed to modify **CNC** state parameters, number parameter, offset data, and transmission PLC ladder graph.

Grade 5: No password. It is allowed to modify offset data, macro-variables; to operate the operation panel of machine tool. It is not allowed to modify **CNC** state parameters, number parameters, or pitch compensation data.

1) In <MDI mode>, enter the interface and move cursor to the target position.



2) Input corresponding password, and press . If the password is correct, the system will give an prompt “password is correct”.



3) For modification of system password, input 0~6 numbers or letters, and press  for confirmation.



4) After modification, press  and move cursor to “logout (END)” button. The interface will



present: “Press <MDI> to confirm logout!” After confirmation by pressing , the interface will present: “logout finished!” At the same time, cursor will get back to the password setting column. After blackout reset, the password will automatically log out, too.

3.3.1.2 System setting and modification of date and time

1) Enter [CNC setting] interface in <MDI mode>.

2) Turn on parameter switch and permission password.

3) Move cursor to the position of date and time. (for example, yyyy-mm-dd)

4) Input the required number. Press <MDI> and cursor will skip to next position.

Note 1: If the new stage password is set in limited shutdown, the setting of date and time will be gray, which means it cannot be modified.

Note 2: After the machine manufacturer password is acquired, you should open the password for staging period before modification of date and time.

3.3.2 Parameter display, modification, and setting

3.3.2.1 Parameter display

1) **Bit parameter page:** Press [parameter] to enter the bit parameter interface. (See Fig.3-3-2-1-1):

BIT PARAMETER		00001							1/00041
NO.	Bit7	Bit6	Bit5	Bit4	Bit3	Bit2	Bit1	Bit0	
0000	****	SVCD	SEQ	MSP	****	INI	INM	PBUS	
	0	0	0	0	0	0	0	1	
0001	****	SPM2	SPPT	SPEP	SPOM	SPT	SBUS	RASA	
	0	0	0	0	0	0	0	0	
0002	****	****	****	DEC5	DEC4	DEC3	DEC2	DEC1	
	0	0	0	0	0	0	0	0	
0003	****	****	****	DIR5	DIR4	DIR3	DIR2	DIR1	
	0	0	0	0	0	1	0	0	
0004	SK0	****	****	****	****	****	****	****	
	0	0	0	0	0	0	0	0	
0005	DOUS	****	****	****	****	****	ISC	****	
	0	0	0	0	0	0	1	0	

DATA	^	S00000	T0700
		14: 34: 29	MDI
	BITPAR	NUMPAR	OFTEN
	GEAR RATE	RETURN	

Fig.3-3-2-1-1

See Appendix I Parameters for the concrete definitions of various parameters.

2) **Number parameter page:** Press [number parameter] to enter the number parameter interface. (See Fig.3-3-2-1-2):

NUM PARAMETER		00001		1/00041
NO.	DATA	MEANING		
0000	2	I/O channel, (1:RS232 2:USB)		
0001	0	STANDBY		
0002	0	STANDBY		
0003	0	STANDBY		
0004	0	STANDBY		
0005	5	CNC controlled axis		
0006	1	CNC Language Select(0:CH 1:EN)		
0007	7	Ahead of times for Limited downtime due reminder		
0008	16	Ethernet bus slave MDI packet capacity		
0009	10	Resend times of BUS		
0010	0.0000	1st axis offset of external workpiece origin		
0011	0.0000	2nd axis offset of external workpiece origin		

DATA	^	S00000	T0700
		14: 34: 39	MDI
	BITPAR	NUMPAR	OFTEN
	GEAR RATE	RETURN	

Fig.3-3-2-1-2

See Appendix I Parameters for the concrete definitions of various parameters.

3) **Common parameters**

OFTEN		00001		1/00041
page: 1/3				Regular Para Content
0. Rapid run/HOME Speed	5. MPG Para/Lubricant			
1. Cutting/JOG Speed	6. Chuck and Tailstock			
2. Axis Direct Para	7. Spindle and C/S Para			
3. Cnc Soft Limit Para	8. Spindle gear para			
4. CNC gear ratio para	9. Tool para			
Press<INPUT>insert, Press 0-9 quickly select				
DATA	^	S00000	T0700	
		14: 34: 51	MDI	
	BITPAR	NUMPAR	OFTEN	
	GEAR RATE	RETURN		

Fig.3-3-2-1-3

On this [common parameter] interface, select the required parameter catalog number to enter the corresponding interface. (See Fig.3-3-2-1-4):

OFTEN			00001		1/000041	
page: 1/3 Rapid run/HOME Speed						
NO.	DATA	MEANING				
P094	8000	Max rapid run speed(all axes)				
P095	0	Min. rapid run speed(all axes)				
P098	4000	1st rapid run speed				
P099	8000	2nd rapid run speed				
P090	8000	3rd rapid run speed				
P091	8000	4th rapid run speed				
P092	8000	5th rapid run speed				
B12. 1	1	positioning(900) interpolation type is(0:non-linear,1:lin				
P093	30	Rapid run override F0 of each axis(all axes)				
B14. 7	0	Rapid feed rate use (0: 4 grade 1: 6 grade)				
1. B:Bitpar P:Numpar K:Kpar T:TMR D:DATA C:CTR						
2. Press <G> go to the parameter part						
Press<HOME> to contact						
DATA	^	50000		T0700		
				14: 35: 10		MDI
		BITPAR	NUMPAR	RTCONT	GEAR RATE	RETURN

Fig.3-3-2-1-4

The operation methods are given below:

- 1) Select <MDI>operation mode.

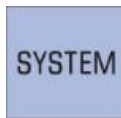

- 2) Press and [number parameter] to enter the [common parameter] display page.



- 3) Select parameter catalog through
- 4) Move cursor to the location of Parameter No.:

Method 1: Press <MDI> to select the block. Press PgUp PgDn to display the page where the parameter to be set is; through arrow keys, move cursor to the position of parameter to be modified.

Method 2: Press corresponding number key followed by <MDI>. Press PgUp PgDn to display the page where the parameter to be set is; through arrow keys, move cursor to the position of parameter to be modified.

- 5) Press <HOME> or [back to catalog] to return to the list of common parameters.
- 6) Press <G> and the interface will jump to the parameter interface of selected parameter.
- 7) For common parameters, the letter ahead of Parameter No. represents parameter type. (B: bit parameter; P: number parameter; K: K parameter; T: T parameter; D: DATA parameter; C: CTR parameter)
- 8) The range of number parameters should be modified on number parameter interface.

Note: The list of common parameters and involved parameters can be freely selected by the user in corresponding configuration document.

3.3.2.2 Modification and setting of parameter value

- 1) Select <MDI>operation mode.

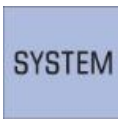
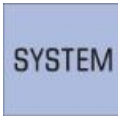
- 2) Press  to enter the <CNC setting> interface. Set the parameter switch at “1”.
- 3) Press  followed by [number parameter] to enter the [bit parameter] or [parameter] or [common parameter] display page.
- 4) Move cursor to the location of parameter number to be modified:
 Method 1: Press PgUp PgDn to display the page where the parameter to be set is; through arrow keys, move cursor to the position of parameter to be modified.

- Method 2: Input Parameter No. and press  for location.
- 5) Input a new parameter through number key (For modification of different levels of parameters, it is required to input corresponding password permission).

- 6) Press  to confirm that the parameter value is input and displayed.
- 7) After setting of all parameters, turn off parameter switch.
- Note:** The [common parameter] interface does not support search function.

3.3.3 Display, modification, and setting of pitch compensation

3.3.3.1 Display of pitch compensation

Press [pitch compensation] to enter the pitch compensation interface, which is shown below (See Fig.3-3-3-1-1):

Pitch Error Compensation				00001	1/00041
NO.	X _{invalid}	Z _{invalid}	C _{invalid}		
0000	0	0	0		
0001	0	0	0		
0002	0	0	0		
0003	0	0	0		
0004	0	0	0		
0005	0	0	0		
0006	0	0	0		
0007	0	0	0		
0008	0	0	0		
0009	0	0	0		
0010	0	0	0		
0011	0	0	0		

DATA	^	S00000	T0700
		14: 36: 07	MDI
SETTING	PARA	PITCH	DATA
		BUS CONF	

Fig.3-3-3-1-1

3.3.3.2 Modification and setting of pitch compensation

- 1) Set the axis pitch error compensation number through number parameters **P216 ~ P220**. Set the axis pitch error compensation space through number parameters **P226 ~ P230**.
- 2) Input the compensation of each point in <MDI mode>.

Note: For setting of pitch compensation, please refer to Part IV Installation and Connection of *PLC Installation and Connection Manual for GSK980TB3i CNC System*.

3.3.4 Data backup, recovery, and transmission

Press [**data**] to enter the setting (data processing) interface. On this interface, it is allowed to back up (store) and recover (read) user data (ladder graph, ladder graph parameter, system parameter, offset, pitch compensation, system macro-variable, user macro-program, CNC part program); it is also allowed to input or output data using U disk or PC. Data backup and recovery do not influence the part program stored in **CNC** (See Fig.3-3-4-1).

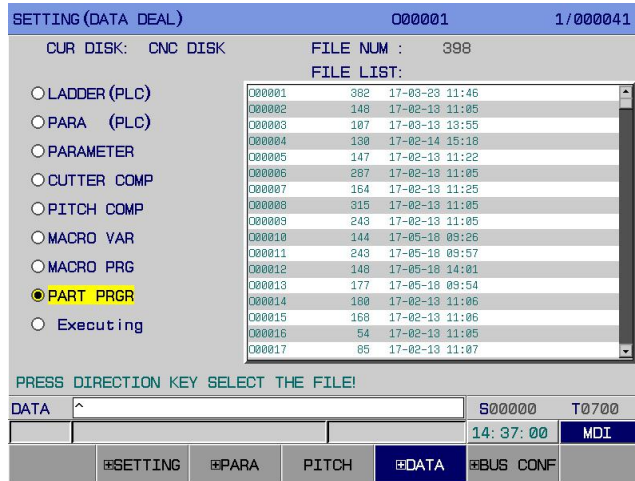

Fig.3-3-4-1

Operation method:

1. Press [CNC setting] to enter the CNC setting interface, and set corresponding password. For password levels corresponding to data operations, please refer to 3.3.1.1 Setting and modification of password permission.
2. Press [**data**] twice to enter the data processing operation interface (as shown in Fig.3-3-4-2).

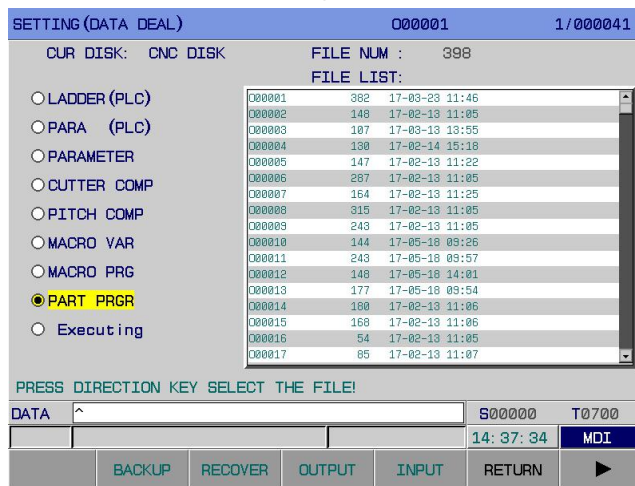

Fig.3-3-4-2

Press [**▶**] to enter the next page





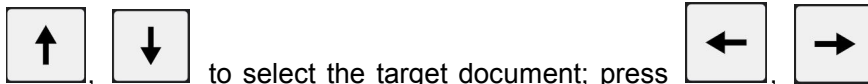

The functions of different operation items are listed in Table 3-3-4-1.

Table 3-3-4-1

Operation Item	Function Description
Data backup	Can back up the data of ladder graph (PLC), parameter (PLC), system parameter, offset, pitch compensation, or system macro-variable singly in system disk. After data backup, the system will generate a backup document whose name has a suffix “.bak”.
Data recovery	Can recover the data of ladder graph (PLC), parameter (PLC), system parameter, offset, pitch compensation, or system macro-variable singly in system disk. Data recovery is to read and recover the backup document in system.
Data output	Can output the data in system disk to an external storage device.
Data input	Can input the data in an external storage device to system disk.
One-touch backup	Can back up multiple data items in system disk simultaneously.
One-touch recovery	Can recover the backup documents of multiple data items simultaneously.
One-touch output	Can copy the documents of multiple data items simultaneously from system disk to U disk.
One-touch input	Can copy multiple documents simultaneously from U disk to corresponding data items in system disk.



3. Press ,  to select the target document; press ,  to switch data item directory and file directory table.

4. Conduct data backup, data recovery, data output, data input, one-touch backup, one-touch recovery, one-touch output, one-touch input operations by pressing corresponding softkeys.

Note:

- 1) When I/O channel is set to be U disk, the data output and data input softkeys have the same function.
- 2) Before data output/input, please ensure I/O channel is set properly. Before the use of U disk, I/O channel should be set to 2; before the use of transmission software on PC, I/O channel should be set to 1.
- 3) The content of one-touch operations is determined by password permission. For the relationship between data items and password permissions, refer to 3.3.1.1 of Operating Instructions.
- 4) Correlation parameters:
 - ①Set, through Bit Para N0:54#7, whether one-touch input/output is effective for part programs or not in the case of debugging or higher permission.
 - ②Set, through Bit Para N0:27#0, whether to forbid the editing of No.80000-89999 subprograms or not.
 - ③Set, through Bit Para N0:27#4, whether to forbid the editing of No.90000-99999 subprograms.
- 5) During data processing, the system set related operation tips, which are listed below: (Table 3-3-4-2)

Table 3-3-4-2

S/N	Message	Cause	Processing
1	one-touch operation completed	Operation success	Transmission completed
2	After completion of one-touch operation, the system prompts: Please modify the parameter before copying.	Have executed the macro-program input/output, but haven't set system related parameters.	Skip the input/out of this file.
3	After completion of one-touch operation, the system gives an alarm: This parameter modification must be followed by once power-off.	Have executed the updating of ladder graph and ladder graph parameter. It is required to power on again.	Transmission completed. Please power on again.
4	Failure to read file	File error	Interrupt input and output.
5	Failure to write file	File error	Interrupt input and output.
6	Failure to copy file	File error	Interrupt input and output.
7	Too large file	Part program is greater than 4M	Interrupt input and output.
8	Insufficient free space	Insufficient disk space	Interrupt input and output.

After sent to the system, LADCHI**.TXT document is invalid until power-off.

3.3.5 Display, modification, and setting of bus servo parameters

Press  [Bus Configuration] to enter the bus interface, which is shown below (See Fig.3-3-5-1):

Fig.3-3-5-1

 [Bus Configuration] interface operating instructions

Press  [Bus Configuration] to enter the bus configuration interface shown in Fig.3-3-5-1. It is allowed to view and modify the parameters here. Concrete operation methods and steps are given below:

- Enter <MDI> operation mode;
- Move cursor, through arrow keys, to the item to be modified;
- Modify parameters according to the following instructions;

1) Bus

2) Encoder type

0: incremental 1: absolute

Note: It is also allowed to set whether to use the absolute encoder or not through Bit Para No: 20#6.

3) Maximum allowable deviation

Note: The system default is 10.000 mm. It can also be set through number parameters P450~P454 and P455~P459.

X and Z axes get back to machine zero at the same time. 0: without expansion card 1: with expansion card

Note: It is also allowed to set whether to use the bus servo card or not through Bit Para No: 0#6.

4) Grating type

0: incremental 1: absolute

Note: It is also allowed to set whether to use the absolute grating or not through Bit Para No: 1#0.

5) Spindle expansion card

0: without expansion card 1: with expansion card

Note: It is also allowed to set whether the spindle drive unit uses bus control mode or not through Bit Para No: 1#1.

6) Absolute zero setting

a) First, set the system-side gear ratio, feed axis direction, and zeroing direction before power-off and power-on.

b) In MDI mode, set “bus or not” at 1 and “encoder type” at 1 on bus configuration interface; move axes to manually to set the position of machine zero point.

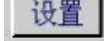
c) Move cursor to . As instructed, press <MDI> twice and the zeroing indicator gets up. Record the current position of absolute encoder of each axis motor as the machine tool zero point. After system power-off and power-on, the zeroing indicator light is out. It is allowed to set negative boundary and positive boundary manually according to the actual maximum stroke of machine tool so that the current absolute coordinate of machine tool shifts a value forward or backward. At last, set Bit Para No.61#6 at 1. Then, the positive and negative limits will be effective.

Setting range: -99999.9999~99999.9999. It is also allowed to set the positive and negative boundaries of each axis through number parameters **P66~P85**.

d) Whether to configure grating. For each axis, set whether to configure grating or not. 0: without grating; 1: with grating.

Note 1: After machine zero setting, modification of zeroing direction, feed axis moving direction, servo or system gear ratio will cause zero loss, which requires re-setting of machine zero point.

Note 2: Re-setting of machine zero point will influence other reference points such as second and third reference points, so these affected points need be reset, too.

3.3.5.1 Display of servo parameters

Press [**F5**Bus Configuration] to enter the servo debugging interface. Then, press [**F6**servo parameter] to enter the servo parameter interface, which is shown below (See Fig.3-3-5-1-1).



SETTING (SERVO):		000001	1/000041
No.	X	Z	C
0000	****	****	****
0001	60	60	0
0002	3.15	3.15	0.00
0003	0	0	0
0004	0	0	0
0005	350	330	0
0006	10	10	0
0007	80	70	0
0008	500	500	0
0009	180	180	0
0010	0	0	0
0011	300	300	0
<small>Password (0 - 9999)</small>			
DATA	^		S00000 T0700
			14:38:32 MDI
	GRADE CLR	BACKUP	COMEBACK
		RETURN	

Fig.3-3-5-1-1

3.3.5.1.1 Modification and setting of servo parameters

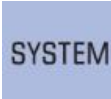
1) Select <MDI> operation mode.

2) Press  to enter the [CNC setting] interface. Set parameter switch at “1”.

3) Press  followed by [Bus Configuration] to enter the servo debugging interface. Then, press [servo parameter] to enter the parameter setting and display page.

4) Move cursor to current axis parameter #0, and input corresponding password. Press ENTER to download the drive unit parameters to system. It is allowed to modify servo parameters on [servo parameter] interface.

5) Move cursor to the position of reference number to be modified:

Method 1: Press PgUp PgDn to display the page where the parameter to be set is; or, through arrow keys, move cursor to the position of parameter to be modified.

Method 2: Input the Parameter No. and press  to locate it.

6) Press  for confirmation. Then, the parameter will be sent to drive unit and the state column will present “Drive unit succeeds in parameter downloading!”.



7) Press  so that servo can save the updated parameter. The state column will present “Drive unit succeeds in parameter saving!”.

8) After the setting of all parameters, turn off parameter switch.

3.3.5.1.2 Servo parameter setting matching motor model

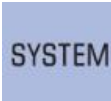
1) Select <MDI> operation mode.

2) Press  to enter the [CNC setting] interface. Set parameter switch at “1”.

3) Press  followed by [Bus Configuration] to enter the servo debugging interface. Then, press [servo parameter] to enter the parameter display page.

4) Move cursor to current axis parameter #0 and input password 385. Press ENTER to download the drive unit parameter to system. It is allowed to modify servo parameters on [servo parameter] interface.

5) Move cursor to parameter #1, and input the value matching motor model:

6) Press  for confirmation. Then, the parameter will be sent to drive unit and the state column will present “Drive unit succeeds in parameter downloading!”.

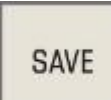
7) Press  so that servo can save the updated parameter. The state column will present “Drive unit succeeds in parameter saving!”.



8) After the setting of all parameters, turn off parameter switch.

3.3.5.1.3 Backup of servo parameters

1) Select <MDI> operation mode.

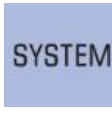
2) Press  to enter the [CNC setting] interface. Set parameter switch at “1”.

3) Press  to enter the [CNC setting] interface. Input **end-user password and higher-level password**.

4) Press  followed by [Bus Configuration] to enter the servo debugging interface. Then, press [servo parameter] to enter the parameter display page.

5) Press [backup] and the current axis parameters can be backed up into a file DrvParXX.txt. (XX-axis number. For example, the filename is DrvPar01.txt for X-axis backup.)



6) After the setting of all parameters, turn off parameter switch.

3.3.5.1.4 Recovery of servo parameters

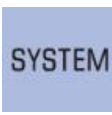
1) Select <MDI> operation mode.

2) Press  to enter the [CNC setting] interface. Set parameter switch at “1”.

3) Press  to enter the [CNC setting] interface. Input **end-user password and higher-level password**.

4) Press  followed by [Bus Configuration] to enter the servo debugging interface. Then, press [servo parameter] to enter the parameter display page.

5) Press [recovery] and the parameter backup file of current axis DrvParXX.txt will be recovered to servo drive. (XX-axis number. For example, the filename is DrvPar01.txt for X-axis backup)

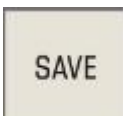
6) Press  so that servo can save the updated parameter. The state column will present “Drive unit succeeds in parameter saving!”.

7) After the setting of all parameters, turn off parameter switch.

3.3.5.1.5 Servo level clearing

During parameter debugging, the machine tool will shake if servo parameters are too rigid. In order to avoid dangers, servo parameters can be recovered to Grade 0 initial state parameters through servo level clearing.

1) Select <MDI> operation mode.

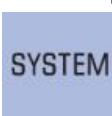
2) Press  to enter the [CNC setting] interface. Set parameter switch at “1”.

3) Press  to enter the [CNC setting] interface. Input **end-user password and higher-level password**.

4) Press  followed by [\oplus Bus Configuration] to enter the servo debugging interface. Then, press [\oplus servo parameter] to enter the parameter display page.

5) Press [level clearing] to recover all servo axis parameters to Grade 0 parameters.

6) Press  so that servo can save the updated parameters. The state column will present “Drive unit succeeds in parameter saving!”.

7) After the setting of all parameters, turn off parameter switch.

3.3.5.2 Servo debugging

In order to ensure servo debugging can reflect the actual servo performance, please cancel the gear ratio at drive side and various offsets at system side (including pitch error compensation and backlash compensation).

3.3.5.2.1 Interface composition

Press [\oplus servo debugging] to enter the servo debugging tool interface, which is shown below (See Fig.3-3-5-2-1-1 ~ Fig.3-3-5-2-2).

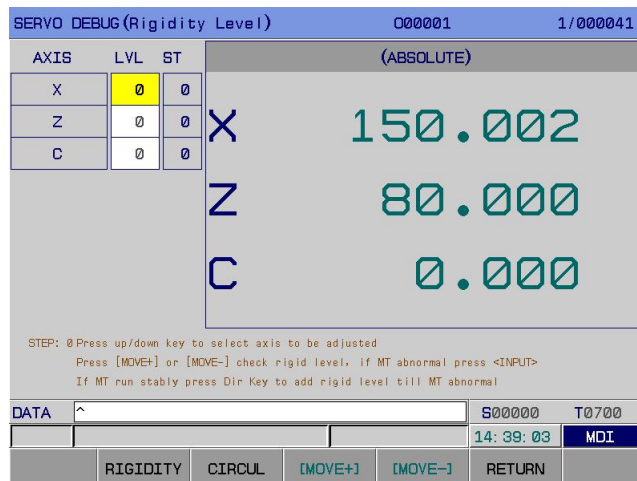

Fig.3-3-5-2-1 Rigid Level Interface

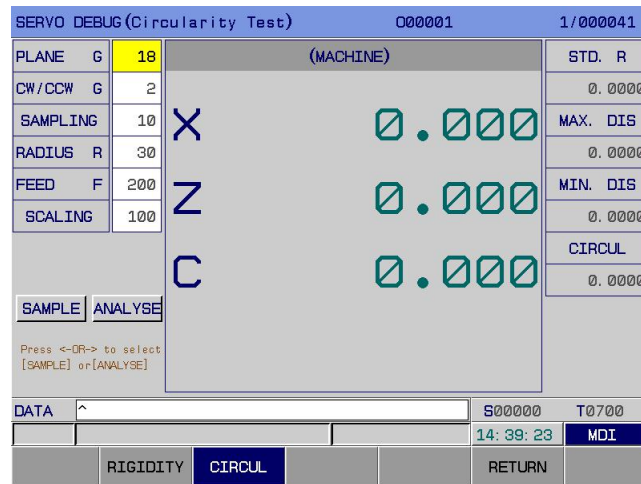

Fig.3-3-5-2-2 Roundness Test Interface

Note: The coordinate axes displayed on servo debugging interface are determined by number of system control axes or number of bus servo slave stations, whichever is lesser.

3.3.5.2.2 Functions

1. Rigid level and parameter optimization

This function is to set servo parameters at the optimal servo performance state.

2. Roundness test

Roundness test can simulate the circle cutting motion circle and collect the position information on motor encoder to judge the synchronicity of machine servo axes' response.



3.3.5.2.3 Operating instructions

1. Rigid level debugging



Explanation: The debugging and setting of rigid level can only be operated specific to one axis once.

Operation keys:



A.  and : Select the axis. (Note: once entering the optimization procedure, the axis being operated cannot be changed through arrow keys.)



B.  and : Decrease or increase the rigid level of current axis. The rigid level decreases or increases by one level after once pressing.

C. [Move +] and [Move -]: Move current axis a certain distance, which is set through Num Para P392, at the speed set through Num Para P393. Before optimization, it is allowed to check whether motor will vibrate or make an abnormal noise by pressing [Move +] and [Move -] repeatedly to move the axis. However, once optimization starts, it is not allowed to acquire motor characteristic data by pressing [Move +] and [Move -] repeatedly to move the axis.

Note 1: Once optimization starts, press [Move +] and [Move -] to move the axis so as to acquire data.

Note 2: Any non-professional person is not allowed to modify Num Para P392 or P393 without permission, or optimization may fail.



D. : Confirm the operation or enter the next step;



E. : Cancel some operation or return to last operation;



F. : Reset the operation, or return to the initial operation step;



G. : Save the operation.



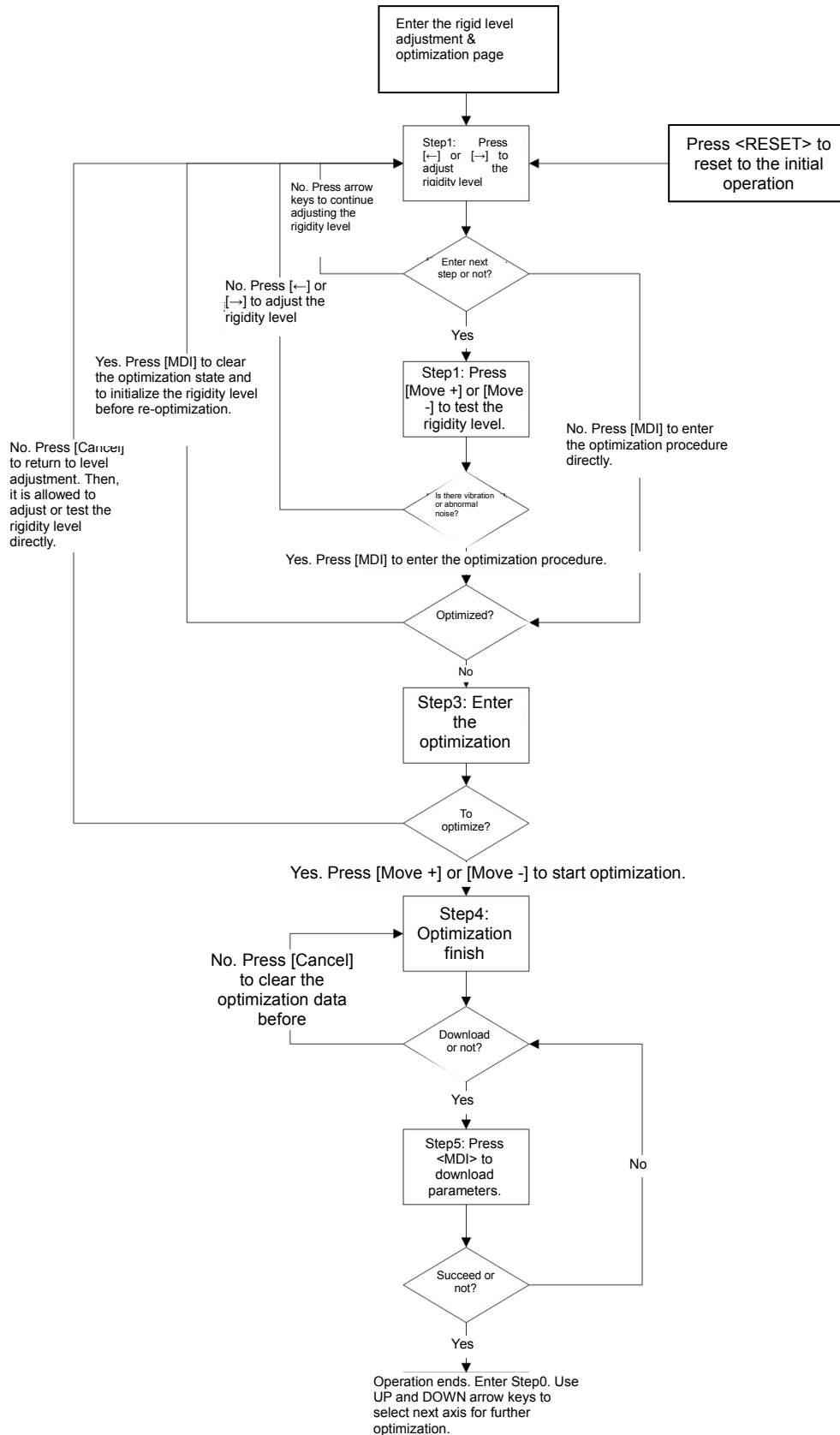



Operation procedure: As shown below:



2. Roundness test

Operation keys:



A. Number keys: Input various parameters;

- B.  and : Select the parameter item;
- C.  and : Select the function (acquisition and analysis);
- D. : Input or confirm the parameter value and execute corresponding operation;
- E. : Clear data and reset to the initial state.



Parameter items:

- F. **Plane:** Select test plane G18;
- G. **Along or against the circle:** Select the circle direction G02 or G03;
- H. **Sampling period:** Set the sampling period according circle radius and feed speed. The greater the radius is, the longer the sampling period should be; the slower the feed speed is, the longer the sampling period is;
- I. **Feed speed:** Movement speed during testing;
- J. **Magnification:** Roundness analysis is the magnification of error.

Operation procedure:

Step 1: Press  or  to select the acquisition function after the setting of parameters;

Step 2: Initiate arc motion and start data acquisition by pressing . After acquisition, press

 or  to select the analysis function.

Step 3: Initiate the analysis function, output the roundness data, and draw the circular error distribution, which is shown below, by pressing .

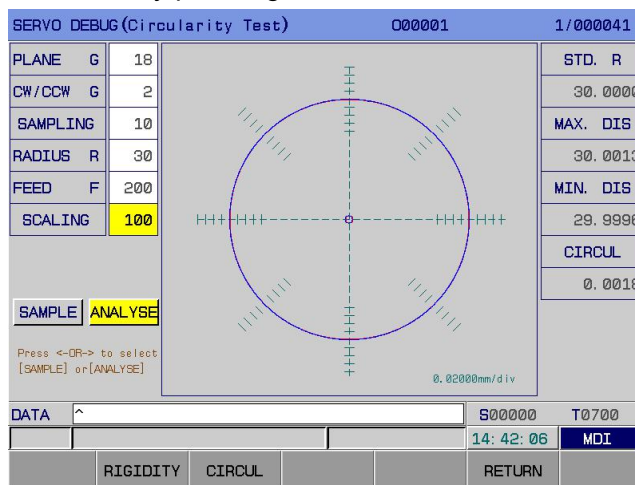

Fig.3-3-5-2-3-1

Note: After debugging of rigid level and parameter optimization, it is required to test the synchronization of current feed axes by using roundness test tools.

If the roundness test of each plane is within 6u, it can be regarded that servo axes move in good synchronicity, and that parameter debugging is basically a success.

3.3.6 Timed shutdown display

3.3.6.1 Setting of timed shutdown

1. Press [System] on system panel followed by [F1] to enter the following interface.

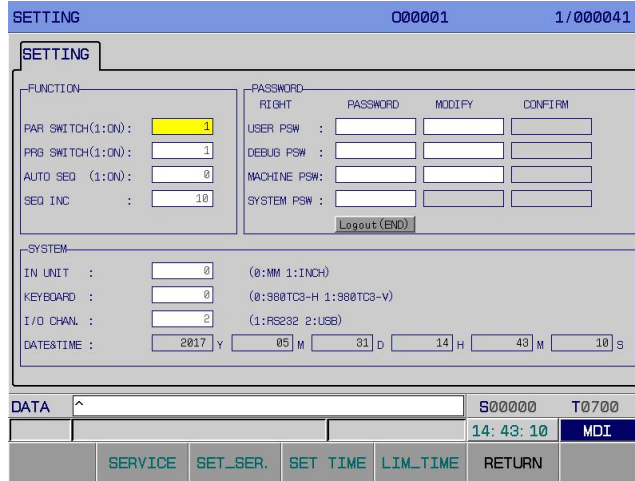

Fig.3-3-6-1

3.4 Offset Display

OFFSET

Press **OFFSET** to enter the offset display interface below. This interface contains 3 sub- interfaces: [**OFFSET**], [**WORK** Workpiece Coordinate], and [**MACRO** Macro-variable], which can be viewed or modified through corresponding softkeys (See Fig.3-4-1):

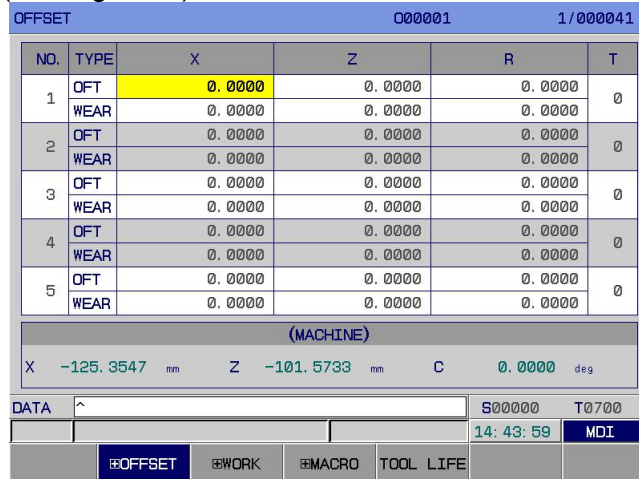

Fig.3-4-1

3.4.1 Display, modification, and setting of bias

Press [**OFFSET**] to enter the bias display page, which is shown below (See Fig.3-4-1-1-1):

NO.		TYPE	X	Z	R	T
1	OFT	0.0000	0.0000	0.0000	0.0000	0
	WEAR	0.0000	0.0000	0.0000	0.0000	
2	OFT	0.0000	0.0000	0.0000	0.0000	0
	WEAR	0.0000	0.0000	0.0000	0.0000	
3	OFT	0.0000	0.0000	0.0000	0.0000	0
	WEAR	0.0000	0.0000	0.0000	0.0000	
4	OFT	0.0000	0.0000	0.0000	0.0000	0
	WEAR	0.0000	0.0000	0.0000	0.0000	
5	OFT	0.0000	0.0000	0.0000	0.0000	0
	WEAR	0.0000	0.0000	0.0000	0.0000	

(MACHINE)			
X	-125.3547 mm	Z	-101.5733 mm
C	0.0000 deg		

DATA		S00000	T0700
		14:44:22	MDI

Meas. in	+INPUT	C INPUT	CTRL	RETURN	▶
----------	--------	---------	------	--------	---

Fig.3-4-1-1

Press  to enter the next page

 CLEN CUR CLEN OFT CLEN WEAR RETURN . It is allowed to input offset directly or to do addition / subtraction with the value at current position.

3.4.1.1 Setting of bias

How to set the tool bias on bias interface:

1) Press  to enter the bias display interface.

2) Move cursor to the position of offset number to be inputted.

Method 1: Press PgUp PgDn to display the page where the compensation amount to be modified is; move cursor to the position of offset number to be modified, through arrow keys.

Method 2: After offset number is inputted, press  to locate it.

3) Input numbers.



A. Bias line:

(1) Press address key ( or ) corresponding to axis name). Input a number, and then



press  on panel or F1 [measuring input] (display value = absolute coordinate - input value); after input, the current abrasion value will be automatically cleared.

(2) Press address key ( or ) corresponding to axis name). Input a number, and then



press  on panel or F2 [+ input]. (display value = current value + input value)



(3) Press address key ( or ) corresponding to axis name) followed by F3[C input]. (display value = relative coordinate - abrasion value)

(4) Press  on panel. Input a number, and then press <MDI>. (display value = input value)

(5) Press  on panel. Input a number (an integer within 0~9), and then press  on panel. (display value =input value)



B. Abrasion line:

1. Press address key ( or  corresponding to axis name) followed by F3[C input]. (display value =relative coordinate –abrasion value)

2. Press address key ( or  corresponding to axis name). Input a number, and then press  on panel or F2[+ input]. (display value =current value +input value)

- Note 1: T column:** It is only allowed to input  on panel. Any other letter inputted is invalid.
- Note 2:** Except the operation above, any operation is wrong in format on bias interface.
- Note 3:** After modification, bias will change in color. It returns after cursor moving or interface switching.

3.4.1.2 Modification of bias value

1) Move cursor to the position of tool bias number to be modified, as stated in 3.4.2.1 of this chapter.
 2) For modification of the tool bias on X-axis, it is required to type U; for modification on Z-axis, it is required to type W; alternatively, select the position of data to be modified and press address key ( or  corresponding to axis name) before input of a number.

3) Press  on panel or **F2 [+ input]**. Add the current tool bias value to the increment value typed. Display the calculation result as new tool bias value.

For example, the tool bias on X-axis set is 5.678, and the increment typed is U1.5. In this case, the new tool bias on X-axis is 7.178 (=5.678+1.5).

- Note 1:** During the modification of tool bias, the new bias cannot come into effect immediately. It takes effect after T code designating its offset number is executed.
- Note 2:** The user can modify the tool offset value at any time during program operation. However, in order that modification can take effect in time, the tool offset value must be modified before its offset number is operated.

3.4.2 Workpiece coordinate setting page

Press [ Workpiece Coordinate] to enter the coordinate system setting interface, which is shown below (See Fig.3-4-2-1).



Fig.3-4-2-1

Except 6 standard workpiece coordinate systems (G54 ~ G59 coordinate systems) shown in Fig.3-4-2-2, each coordinate system is viewed or modified through PgUp PgDn. For operations of additional coordinate system, see *Programming—4.2.7 Additional Workpiece Coordinate System*.

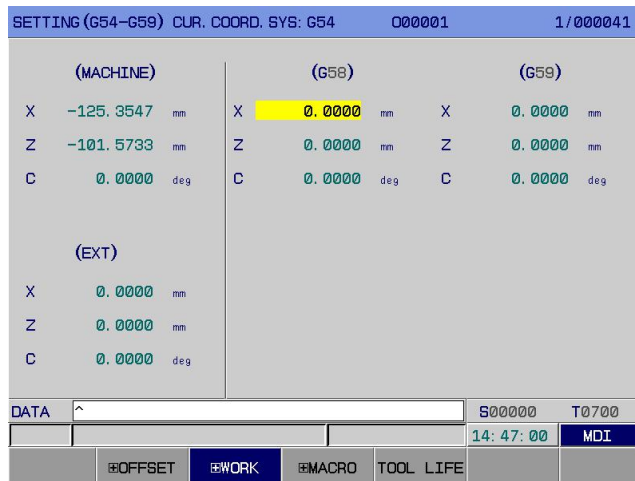















Fig.3-4-2-2

3.4.2.1 Direct input (number)

Enter workpiece coordinate system setting page. Move cursor to the position of typing through  and . Input a number, and press . In this way, you input the number directly. (See Fig.3-4-3-2)

3.4.2.2 Two methods for coordinate input

Method 1: Move cursor to the position of typing through  and . Press an address key (,  corresponding to axis name), and input a number. Press  and CNC will automatically input the data;

Method 2: Move cursor to the position of typing through  and . Then, press an address key (,  corresponding to axis name), and input a number. Press  softkey and CNC will automatically input the data;

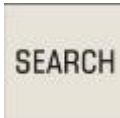

Coordinate system searching method:

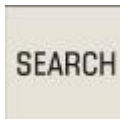
1) In any mode, input a coordinate system and press  for location. For example, input "G56".

2) In any mode, input "P6" or "P06" and press . Cursor will be located at the additional workpiece coordinate system "G54 P06".

3.4.2.3 Modification of workpiece coordinate system

Enter workpiece coordinate system setting page. Move cursor to the position of data to be modified

through  and . Input a number, and then press F3[+ input] to add current bias of workpiece coordinate system to the increment value inputted. The calculation result will be displayed as new bias value of coordinate system. (display value =current value + input value) See Fig.3-4-3-3-1

SETTING (G54-G59) CUR. COORD. SYS: G54			000001	1/000041	
(MACHINE)			(G54)	(G55)	
X	-125.3547 mm	X	0.0000 mm	X	0.0000 mm
Z	-101.5733 mm	Z	0.0000 mm	Z	0.0000 mm
C	0.0000 deg	C	0.0000 deg	C	0.0000 deg
(EXT)			(G56)	(G57)	
X	0.0000 mm	X	0.0000 mm	X	0.0000 mm
Z	0.0000 mm	Z	0.0000 mm	Z	0.0000 mm
C	0.0000 deg	C	0.0000 deg	C	0.0000 deg
DATA	^		S00000	T0700	
			14:47:48	MDI	
		+INPUT	Meas. in	RETURN	

Fig.3-4-2-3-1

3.4.2.4 Clearing of workpiece coordinate system

Enter workpiece coordinate system setting page, and press . When all bias values of workpiece coordinate system are cleared, system will display a prompt. In this case, it is required to

press  again to delete all bias values. It is allowed to press <cancel> to cancel the deletion operation; it is also allowed to set any axis bias at 0 with the direct input method stated in this chapter.

3.4.3 Display, modification, and setting of macro-variables

3.4.3.1 Display of macro-variables

Press [Macro-variable] to enter the macro-variable page. This page contains the following 2 sub-interfaces: [user variable] and [system variable], which can be viewed or modified through corresponding softkeys.

1) **User variable page:** Press [user variable] to enter the user variable interface (See Fig.3-4-3-1-1):

COMMON VARIABLES		00001		1/000041	
NO.	DATA	NO.	DATA		
0000		0012			
0001		0013			
0002		0014			
0003		0015			
0004		0016			
0005		0017			
0006		0018			
0007		0019			
0008		0020			
0009		0021			
0010		0022			
0011		0023			

NOTE: NULL VARIABLES

DATA ^ S00000 T0700

14:48:12 MDI

CUSTOMER SYSTEM RETURN

Fig.3-4-3-1-1

2) **System variable page:** Press [system variable] to enter the system variable interface (See Fig.3-4-3-1-2):

SYSTEM VARIABLES		00001		1/000041	
NO.	DATA	NO.	DATA		
1000	0	1012	0		
1001	0	1013	0		
1002	0	1014	0		
1003	0	1015	0		
1004	0	1016	0		
1005	0	1017	0		
1006	0	1018	0		
1007	0	1019	0		
1008	0	1020	0		
1009	0	1021	0		
1010	0	1022	0		
1011	0	1023	0		

NOTE: INPUT INTERFACE SIGNAL

DATA ^ S00000 T0700

14:48:42 MDI

CUSTOMER SYSTEM RETURN

Fig.3-4-3-1-2

For details of macro-variable instructions and usage, see *Programming—4.7.2 Macro-variables*.

3.4.3.2 Modification and setting of macro-variables

1) Select <MDI> operation mode.

SYSTEM

2) Press [SYSTEM] followed by [Macro-variable] to enter the macro-variable display page.

3) Move cursor to the position of variable number to be modified:

Method 1: Press PgUp PgDn to display the page where the variable to be set is; move cursor to the position of variable to be modified, through arrow keys.

SEARCH

Method 2: Input a variable number and press **SEARCH** for location.

4) Input a new value through number keys.

INPUT

5) Press **INPUT** to confirm the value is inputted and displayed.

3.5 Graphic Display

GRAPH

Press **GRAPH** to enter the following graph page. This page contains 2 display interfaces: **[graphical parameter]** and **[GRAPH]**, which can be switched through corresponding softkeys. (See Fig.3-5-1):

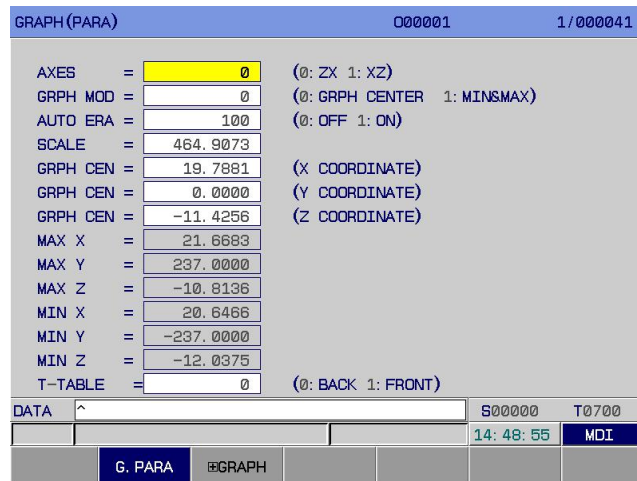

Fig.3-5-1

1) Graphical parameter interface: Press **[graphical parameter]** to enter the graphical parameter interface, as shown in Fig.3-5-1.

A. Meaning of graphical parameters

Coordinate selection: Set a drawing plane. There are 2 selection modes (0~1), as shown in second line.

Graphic mode: Set the graphic display mode.

Auto erase: Set this period to be 1 hour. After a program ends, its graph is automatically erased when next circulation start-ups.

Scale: Set the scale of drawing.

Graphic center: Set the workpiece coordinate corresponding to LCD center the in workpiece coordinate system.

Maximum and minimum: After the maximum and minimum of each display axis are set, CNC system will set the scale and graphic center the automatically.

X_{max} : maximum in X direction in graphic display (Unit: 0.0001 mm / 0.0001 inch)

X_{min} : minimum in X direction in graphic display (Unit: 0.0001 mm / 0.0001 inch)

Y_{max} : maximum in Y direction in graphic display (Unit: 0.0001 mm / 0.0001 inch)

Y_{min} : minimum in Y direction in graphic display (Unit: 0.0001 mm / 0.0001 inch)

Z_{max}: maximum in Z direction in graphic display (Unit: 0.0001 mm / 0.0001 inch)

Z_{min}: minimum in Z direction in graphic display (Unit: 0.0001 mm / 0.0001 inch)

tool rest selection: Modify this parameter according to the type of machine tool rest, in order that graphic display can reflect the actual conditions of machine more intuitively. There are 2 selection modes (0-1), as shown in second line.

Note: The settings of X_{max} and X_{min} are radius values.

B. Graphical parameters setting method

- a) Move cursor to the parameter to be set;
- b) Type a corresponding value as required;



c) Press  for confirmation.







2) Graph interface: Press  to enter the graph interface. (See Fig.3-5-2):



Fig.3-5-2

Press , , ,  to move the graphic display area, and the display boundary will expand 1 time at most.

In graph page, it is allowed to monitor the machining track of program in operation.

A. Press [start] or  to start drawing. At this point, "*" number moves to **S**: before **drawing starts**;

B. Press [Stop] or  to stop drawing. At this point, "*" number moves to **T**: before **drawing stops**;

C. Once [switch] is pressed, the graph switches between coordinates corresponding to **0 ~ 1**.

D. Press [clear] or  to clear the graph drawn.

3.6 Diagnosis Display

The state of DI/DO signal between **CNC** and machine tool, state of signal between **CNC** and **PLC**, **PLC** internal data, and **CNC** internal state are displayed on diagnosis page. For the meaning and

setting method of each diagnosis number, please refer to *GSK 980TB3i CNC System and PLC Installation & Connection Manual*.

This part of diagnosis is non-modifiable and used for detecting the operating conditions of interface signal and internal signal of **CNC**.



Press  to enter the diagnosis display interface. This page contains 5 sub- interfaces: [Signal], [System], [Bus], [DSP], and [Waveform], which can be viewed through corresponding softkeys (See Fig.3-6-1).

DIAGNOSE (NC→PLC)				000001				1/000041										
NO.	DATA								NO.	DATA								
F000	0	1	0	0	0	0	0	0	0	F012	0	0	0	0	0	0	0	0
F001	0	0	0	0	0	0	0	0	0	F013	0	0	0	0	0	0	0	0
F002	0	0	0	0	0	0	0	0	0	F014	0	0	0	0	0	0	0	0
F003	0	0	0	0	1	0	0	0	0	F015	0	0	0	0	0	0	0	0
F004	0	0	0	0	0	1	0	0	0	F016	0	0	0	0	0	0	0	0
F005	0	0	0	0	0	0	0	0	0	F017	0	0	0	0	0	0	0	0
F006	0	0	0	0	0	0	0	0	0	F018	0	0	0	0	0	0	0	0
F007	0	0	0	0	0	0	0	0	0	F019	0	0	0	0	0	0	0	0
F008	0	0	0	0	0	0	0	0	0	F020	0	0	0	0	0	0	0	0
F009	0	0	0	0	0	0	0	0	0	F021	0	0	0	0	0	0	0	0
F010	0	0	0	0	0	0	0	0	0	F022	0	0	0	0	0	0	0	0
F011	0	0	0	0	0	0	0	0	0	F023	0	0	0	0	0	0	0	0

OP SA STL SPL ***** FWD

Rewinding signal

DATA ^ S00000 T0102

14:52:48 MDI

⊞SIGNAL SYSTEM BUS ⊞USERDGN ⊞WAVE

Fig.3-6-1

3.6.1 Diagnosis data display

3.6.1.1 Display of signal parameters

Press [Signal] to enter the signal diagnosis interface, which is shown below (See Fig.3-6-1-1-1~Fig.3-6-1-1-4).

1、 F signal interface: On <Diagnosis> interface, press [F Signal] to enter the diagnosis (NC→PLC) interface, as shown in Fig.3-6-1-1-1:

DIAGNOSE (NC→PLC)				000001				1/000041										
NO.	DATA								NO.	DATA								
F000	0	1	0	0	0	0	0	0	0	F012	0	0	0	0	0	0	0	0
F001	0	0	0	0	0	0	0	0	0	F013	0	0	0	0	0	0	0	0
F002	0	0	0	0	0	0	0	0	0	F014	0	0	0	0	0	0	0	0
F003	0	0	0	0	1	0	0	0	0	F015	0	0	0	0	0	0	0	0
F004	0	0	0	0	0	1	0	0	0	F016	0	0	0	0	0	0	0	0
F005	0	0	0	0	0	0	0	0	0	F017	0	0	0	0	0	0	0	0
F006	0	0	0	0	0	0	0	0	0	F018	0	0	0	0	0	0	0	0
F007	0	0	0	0	0	0	0	0	0	F019	0	0	0	0	0	0	0	0
F008	0	0	0	0	0	0	0	0	0	F020	0	0	0	0	0	0	0	0
F009	0	0	0	0	0	0	0	0	0	F021	0	0	0	0	0	0	0	0
F010	0	0	0	0	0	0	0	0	0	F022	0	0	0	0	0	0	0	0
F011	0	0	0	0	0	0	0	0	0	F023	0	0	0	0	0	0	0	0

OP SA STL SPL ***** FWD

Rewinding signal

DATA ^ S00000 T0102

14:52:57 MDI

F SIGNAL G SIGNAL X SIGNAL Y SIGNAL RETURN

Fig.3-6-1-1-1

This is the signal system gives to PLC. For the meaning and setting method of each diagnosis number, please refer to *GSK 980TB3i CNC System and PLC Installation & Connection Manual*.

2、 G signal interface: On <Diagnosis> interface, press [G Signal] to enter the diagnosis (PLC→NC)

interface, as shown in Fig.3-6-1-1-2:

DIAGNOSE (PLC→ND)				000001				1/000041										
NO.	DATA								NO.	DATA								
G000	0	0	0	0	0	0	0	0	0	G012	0	0	0	0	1	0	1	0
G001	0	0	0	0	0	0	0	0	0	G013	0	0	0	0	0	0	0	0
G002	0	0	0	0	0	0	0	0	0	G014	0	0	0	0	0	0	0	0
G003	0	0	0	0	0	0	0	0	0	G015	0	0	0	0	0	0	0	0
G004	0	0	0	0	1	0	0	0	0	G016	0	0	0	0	0	0	0	0
G005	0	0	0	0	0	0	0	0	0	G017	0	0	0	0	0	0	0	0
G006	0	0	0	0	0	0	0	0	0	G018	0	0	0	0	0	0	0	0
G007	0	0	0	0	0	0	0	0	0	G019	0	0	0	0	0	0	0	0
G008	0	0	1	1	0	0	0	0	0	G020	0	0	0	0	0	0	0	0
G009	0	0	0	0	0	0	0	0	0	G021	0	0	0	0	0	0	0	0
G010	0	0	0	0	0	0	0	0	0	G022	0	0	0	0	0	0	0	0
G011	0	0	0	0	0	0	0	0	0	G023	0	0	0	0	0	0	0	0

ED07 ED06 ED05 ED04 ED03 ED02 ED01 ED00
Data signal for external data input

DATA ^ S00000 T0102
14:53:06 MDI

F SIGNAL G SIGNAL X SIGNAL Y SIGNAL RETURN

Fig.3-6-1-1-2

This is the signal PLC gives to system. For the meaning and setting method of each diagnosis number, please refer to *GSK 980TB3i CNC System and PLC Installation & Connection Manual*.

3, X signal interface: On <Diagnosis> interface, press [X Signal] to enter the diagnosis (MT→PLC) interface, as shown in Fig.3-6-1-1-3:

DIAGNOSE (MT→PLC)				000001				1/000041										
NO.	DATA								NO.	DATA								
X000	0	0	0	0	0	0	0	0	0	X012	0	0	0	0	0	0	0	0
X001	1	0	0	0	0	0	0	0	0	X013	0	0	0	0	0	0	0	0
X002	0	1	0	0	0	0	0	0	0	X014	0	0	0	0	0	0	0	0
X003	0	0	0	1	0	0	0	1	0	X015	0	0	0	0	0	0	0	0
X004	0	0	0	0	0	0	0	0	0	X016	0	0	0	0	0	0	0	0
X005	0	0	0	0	0	0	0	0	0	X017	0	0	0	0	0	0	0	0
X006	0	0	0	0	1	0	1	0	0	X018	0	0	0	0	0	0	0	0
X007	0	0	0	0	0	0	0	0	0	X019	0	0	0	0	0	0	0	0
X008	0	0	0	0	0	0	0	0	0	X020	0	0	0	0	0	0	0	0
X009	0	0	0	0	0	0	0	0	0	X021	0	0	0	0	0	0	0	0
X010	0	0	0	0	0	0	0	0	0	X022	0	0	1	0	0	1	0	0
X011	0	0	0	0	0	1	0	0	0	X023	0	0	0	0	0	0	0	0

*DOOR DECZ DECX *LTZ- *LTZ *LTX- *LTX
1st axis limited signal(forward as double switch)

DATA ^ S00000 T0102
14:53:17 MDI

F SIGNAL G SIGNAL X SIGNAL Y SIGNAL RETURN

Fig.3-6-1-1-3

This is the signal machine tool gives to PLC. For the meaning and setting method of each diagnosis number, please refer to *GSK 980TB3i CNC System and PLC Installation & Connection Manual*.

4, Y signal interface: On <Diagnosis> interface, press [Y Signal] to enter the (PLC→MT) interface, as shown in Fig.3-6-1-1-4:

DIAGNOSE (PLC->MT)				00001				1/000041					
NO.	DATA				NO.	DATA							
Y000	1	0	0	0	1	0	1	0	Y012	0	0	0	0
Y001	0	0	0	0	0	0	1	0	Y013	0	0	0	0
Y002	0	0	0	0	0	0	0	1	Y014	0	0	0	0
Y003	0	0	0	1	0	0	0	0	Y015	0	0	0	0
Y004	0	0	0	0	0	0	0	0	Y016	0	0	0	1
Y005	0	0	0	0	0	0	0	0	Y017	0	1	0	0
Y006	0	0	0	0	0	0	0	1	Y018	0	0	0	0
Y007	0	0	0	0	0	0	0	0	Y019	0	0	0	0
Y008	0	0	0	0	0	0	0	0	Y020	0	0	0	0
Y009	0	0	0	0	0	0	0	0	Y021	0	1	0	0
Y010	0	0	0	0	0	0	0	0	Y022	1	0	1	0
Y011	0	0	0	0	0	0	0	0	Y023	0	1	0	1

YELLOW RED GREEN ***** M32 YOPEN M08 BRAKE
Feed axis brake

DATA ^ S00000 T0102
14:53:28 MDI

F SIGNAL G SIGNAL X SIGNAL Y SIGNAL RETURN

Fig.3-6-1-1-4

This is the signal PLC gives to machine tool. For the meaning and setting method of each diagnosis number, please refer to *GSK 980TB3i CNC System and PLC Installation & Connection Manual*.

3.6.1.2 Display of system parameters

Press [System] to enter the system signal diagnosis interface, which is shown below (See Fig.3-6-1-2-1).

DIAGNOSE (SYSTEM)				00001				1/000041			
NO.	DATA	MEAN									
000	-376754	1st send to DSP pulses drv via elec gear ratio									
001	0	2nd send to DSP pulses drv via elec gear ratio									
002	711413	3rd send to DSP pulses drv via elec gear ratio									
003	0	4th send to DSP pulses drv via elec gear ratio									
004	0	5th send to DSP pulses drv via elec gear ratio									
005	0	Send to DSP tapping axis pulses drv via elec gear ratio									
006	0.0000	1st Spindle Analog voltage output									
007	0.0000	2nd Spindle Analog voltage output									
008	00000000	Each axis Ref. point signal									
009	3	M code being executed									
010	800	S code being executed									
011	1	T code being executed									

DATA ^ S00000 T0102
14:53:45 MDI

⊞SIGNAL SYSTEM BUS ⊞USERDGN ⊞WAVE

Fig.3-6-1-2-1

3.6.1.3 Display of bus parameters

Press [Bus] to enter the bus signal diagnosis interface, which is shown below (See Fig.3-6-1-3-1).

DIAGNOSE (BUS)EM			00001	1/000041
NO.	DATA	MEAN		
000	3	Bus link slave qty		
001	2	Bus servo slave qty		
002	0	Bus servo card slave qty		
003	0	Bus IO card slave qty		
004	0	Bus DAQ card slave qty		
005	0	Bus DAQ card slave qty		
006	0	Bus spindle slave qty		
007	1	FPQALINK realtime state word		
008	0	Bus realtime link state,1:normal,0:abnor		
009	49173	FPQALINK retransmission once times		
010	1	FPQALINK retransmission twice times		
011	1	FPQALINK invalid MDT packet counter		

DATA	^	S00000	T0102
		14: 53: 59	MDI
	≡SIGNAL	SYSTEM	BUS
	≡USERDGN	≡WAVE	

Fig.3-6-1-3-1

3.6.1.4 Display of DSP parameters

Press [DSP] to enter the system signal diagnosis interface, which is shown below (See Fig.3-6-1-4-1).

诊断 (DSP)			00001	1/000041
序号	数据	说明		
000	0	DSP扫描计数器		
001	0	DSP插补控制点个数		
002	0	DSP插补完成任务次数		
003	0	DSPx1348 错误报警		
004	0	DSPx1344错误报警		
005	0	DSPx1344插补缓冲区大小		
006	0	DSP任务完成标志		
007	0	DSP插补点缓冲区大小		
008	0	DSP插补拟合点个数		
009	0	DSPx1348 信号捕获		
010	0	DSP信号捕获1		
011	0	DSP信号捕获2		

输入	^	S00000	T0000
		22: 06: 04	录入方式
	≡信号	系统	总线
		DSP	≡波形

Fig.3-6-1-4-1

3.6.1.5 Display of waveform parameters

Press [Waveform] to enter the waveform interface, as shown in Fig.3-6-1-5-1:

DIAGNOSE WAVE			00001	1/000041
AXIS	0	(0: ALL 1: 1st 2: 2nd 3: 3rd 4: 4th 5: 5th)		
WAVE TYPE	0	(0: Speed 1: Acc 2: Acc Acc)		
HOR SCALE	5	VER SCALE	500	

DATA	^	S00000	T0102
		14: 59: 04	MDI
	STOP		RETURN

启动			返回
----	--	--	----

Fig.3-6-1-5-1

Axis selection: Select the axis for waveform diagnosis.

Waveform selection: Select the content of waveform for diagnosis.

Horizontal axis and longitudinal axis scale: Select the scale of graph to be drawn.

INPUT

Data: In any mode, input corresponding data and press

Press <start> to start signal monitoring, and <stop> to stop it.

3.6.2 Viewing of signal state

DIAGNOSIS

1) Press

2) There are corresponding address explanation and meaning at lower left of screen during left & right moving of cursor.

SEARCH

3) Move cursor or input the parameter address to be searched, and then press

4) [Waveform] interface can display the speed, acceleration, and jerk of each feed axis, in order for debugging and to obtain the best fitting parameters for drive and motor.

3.7 Alarm Display

In the case a system exception alarm, the “alarm” message is displayed at lower left of screen. In this

ALARM

case, press

It contains 4 display interfaces: [alarm], [user], [history], [resume], which are switched through corresponding softkeys (See Fig.3-7-1 ~ Fig.3-7-4). It is allowed to set whether to switch to alarm interface or not in the case of an alarm, through Bit Para N0: 24#6.

1. Alarm interface: On <alarm> interface, press [alarm] to enter the alarm interface, as shown in Fig.3-7-1:

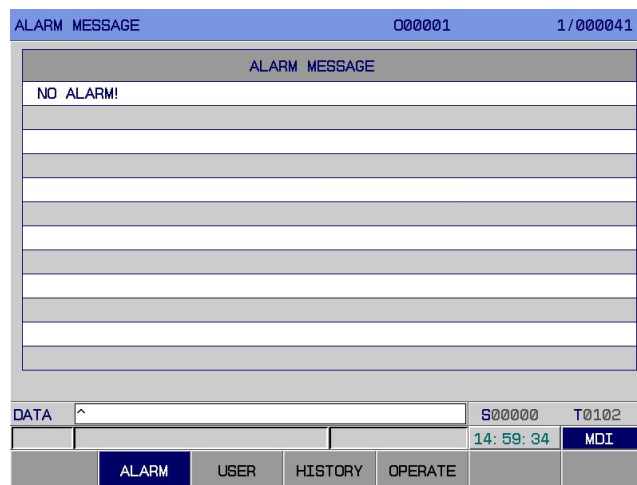

Fig.3-7-1

Alarm display page displays the details of current P/S alarm number. See Appendix II.

2. User interface: On <alarm> interface, press [user] to enter the external alarm interface, as shown

in Fig.3-7-2:



Fig.3-7-2

For details of each user alarm message, please refer to *GSK 980TB3i CNC System and PLC Installation & Connection Manual*.

Note: For external alarms, the user can set and edit the alarm number independently according to actual conditions. The alarm content after editing is inputted by system transmission software to system. External alarms are to edit A of file LadChi**.txt, and the latter two digits are set according to the bit parameters 53.0 ~ 53.3. (default is 01, i.e., filename is LadChi01.txt)

3. History interface: On <alarm> interface, press [history] to enter the historical alarm message interface, as shown in Fig.3-7-3:

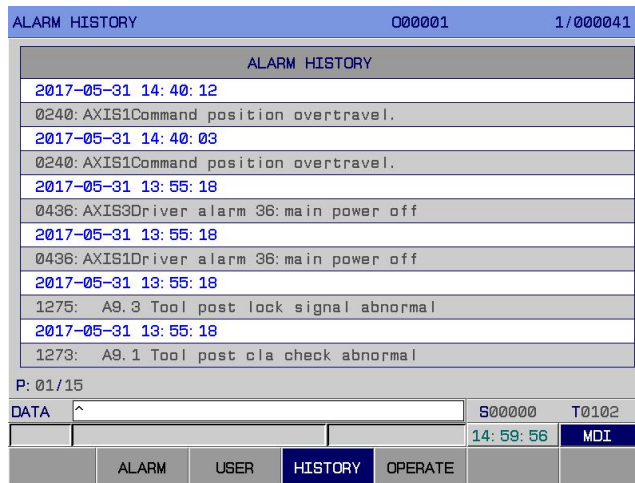

Fig.3-7-3

On this interface, messages are arranged from latest to earliest, for the convenience of user viewing.

4. Resume interface: On <alarm> interface, press [resume] to enter the resume interface, as shown in Fig.3-7-4:

operation resume interfaces display the information on modification of system parameters and ladder graph, including modification content and modification time.

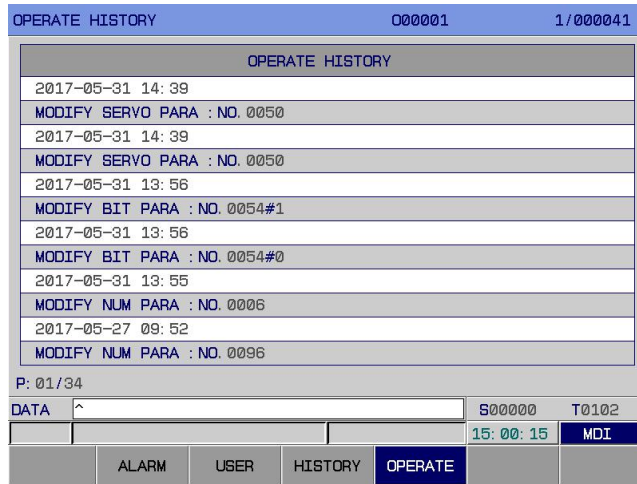
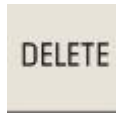
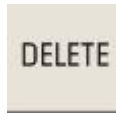

Fig.3-7-4

An operation resume has 34 pages, including 9 pages of historical alarm messages such as alarm time, alarm number, alarm message, and page number, which are viewed through PgUp PgDn.



The history and resume records can be deleted through  (if the password level is debugging or higher).

3.8 Ladder Graph Display

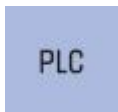



Press  to enter the following ladder graph display page, containing 5 display interfaces: [ladder graph information], [ladder Graph], [ladder graph parameter], [signal diagnosis], [signal tracking], which can be switched through corresponding softkeys (See Fig.3-8-1 ~ 3-8-5).



Fig.3-8-1

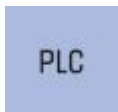
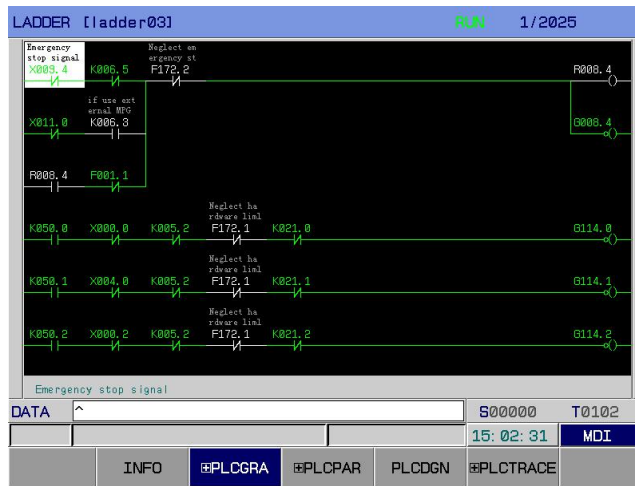

Fig.3-8-2

The screenshot shows the 'K PARAMETER' table with the following data:

NO.	Bit7	Bit6	Bit5	Bit4	Bit3	Bit2	Bit1	Bit0
K000	0	0	0	0	0	0	0	0
K001	0	0	0	0	0	1	1	1
K002	0	0	0	0	0	0	1	0
K003	0	0	0	0	0	0	0	0
K004	0	0	0	0	0	0	0	0
K005	0	0	0	0	0	0	0	1
K006	0	0	0	0	0	1	0	0
K007	1	0	0	1	0	0	0	1
K008	1	0	0	1	0	0	0	0
K009	0	0	0	0	0	0	1	1
K010	0	0	0	0	0	0	0	0
K011	0	0	0	1	0	0	0	1

The interface includes a 'DATA' field with 'S00000' and 'T0102', a time display of '15:02:40', and a menu with 'PLCPAR' selected.

Fig.3-8-3

The screenshot shows the 'SIGNAL DIAGNOSE' table with the following data:

NO.	Bit7	Bit6	Bit5	Bit4	Bit3	Bit2	Bit1	Bit0
F000	0	1	0	0	0	0	0	0
F001	0	0	0	0	0	0	0	0
F002	0	0	0	0	0	0	0	0
F003	0	0	0	0	1	0	0	0
F004	0	0	0	0	0	1	0	0
F005	0	0	0	0	0	0	0	0
F006	0	0	0	0	0	0	0	0
F007	0	0	0	0	0	0	0	0
F008	0	0	0	0	0	0	0	0
F009	0	0	0	0	0	0	0	0
F010	0	0	0	0	0	0	0	0
F011	0	0	0	0	0	0	0	0

The interface includes a 'DATA' field with 'S00000' and 'T0102', a time display of '15:02:50', and a menu with 'PLCDGN' selected.

Fig.3-8-4

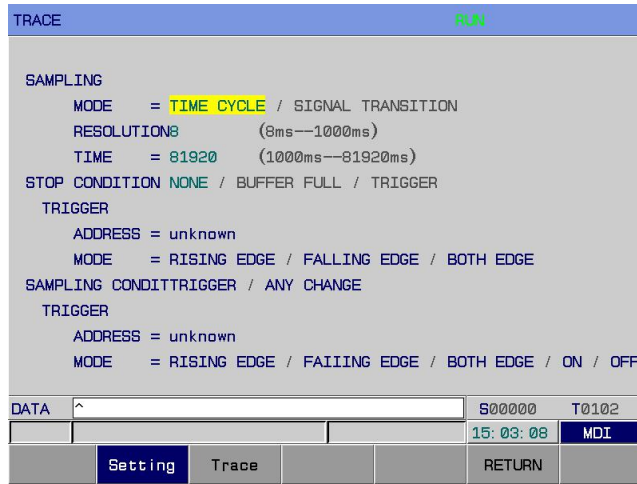

Fig.3-8-5

Note: For modification method and information related to PLC ladder graph, please refer to *GSK 980TB3i CNC System and PLC Installation & Connection Manual*.

3.9 Help Display



Press **HELP** to enter the help display page. This page contains 8 display interfaces: [system information] [Operations] [Alarms] [G Codes] [Parameter List] [Macro Command] [**+** PLC.AD] [Calculator], which can be viewed through corresponding softkeys, as shown below (See Fig.3- 9- 1 ~ 3- 9- 12).

1. System information interface: On <Help> interface, press [system information] to enter the system information interface, as shown in Fig.3-9-1:

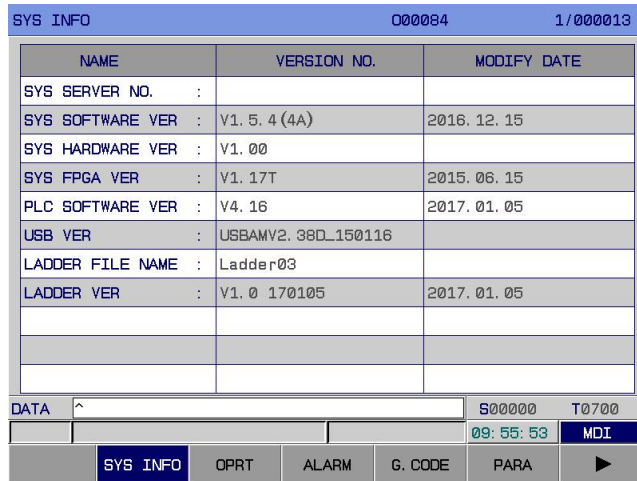

Fig.3-9-1

2. Operation table interface: On <Help> interface, press [Operations] to enter the help information (operation table) interface, as shown in Fig.3-9-2:

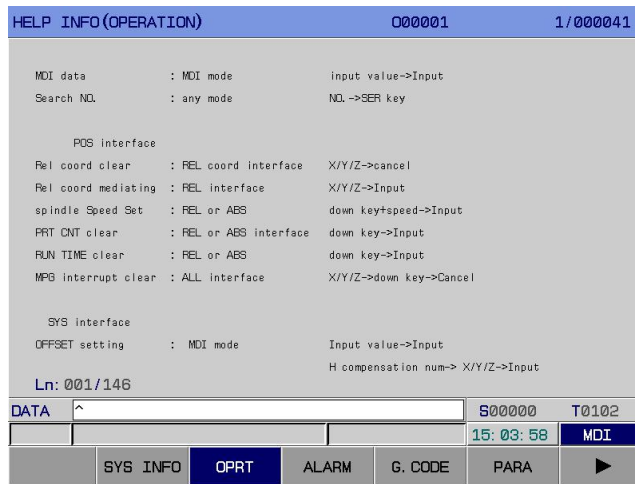

Fig.3-9-2

Help information (operation table) interface introduces various operation procedures and methods on different interfaces in detail. One that is unfamiliar with or unclear about operations can search and check corresponding procedures and methods on help interface.

3. Alarm table interface: On <Help> interface, press [Alarms] to enter the help information (alarm table) interface, as shown in Fig.3-9-3:

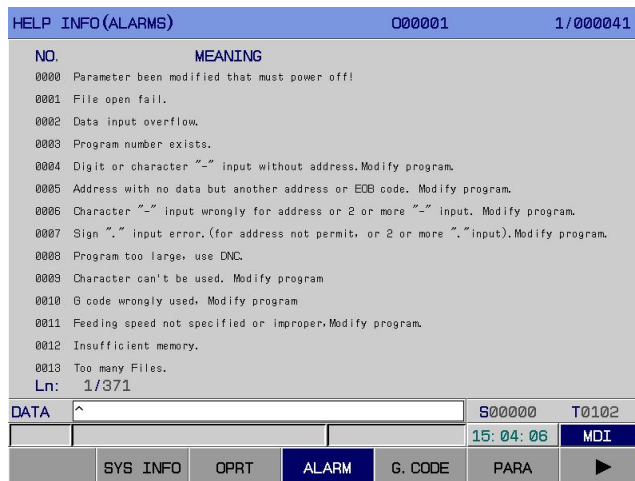

Fig.3-9-3

This interface introduces the meaning and treatment method of each alarm number in detail.

4. G code table interface: On <Help> interface, press [G Codes] to enter the help information (G code table) interface, as shown in Fig.3-9-4:

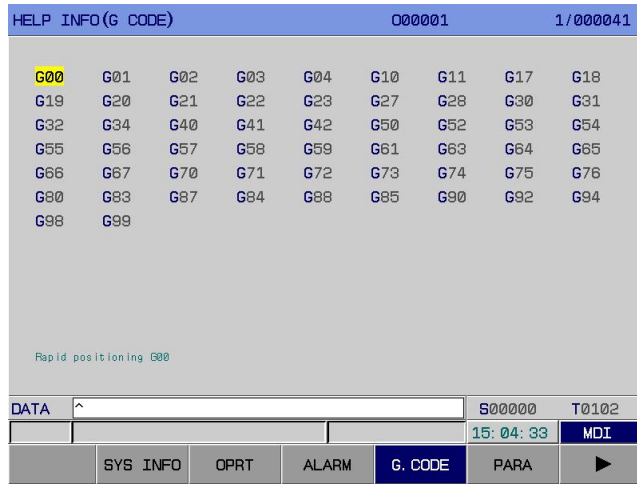

Fig.3-9-4

G code interface introduces the definition of each G code used by system. Select a G code to be viewed with cursor, and you will see its definition at lower left of interface, as shown in Fig.3-9-4. For

concrete format and usage about G code, select a G code and press **INPUT** on panel. Then,

press **HOME** to get back, as shown in Fig.3-9-5:

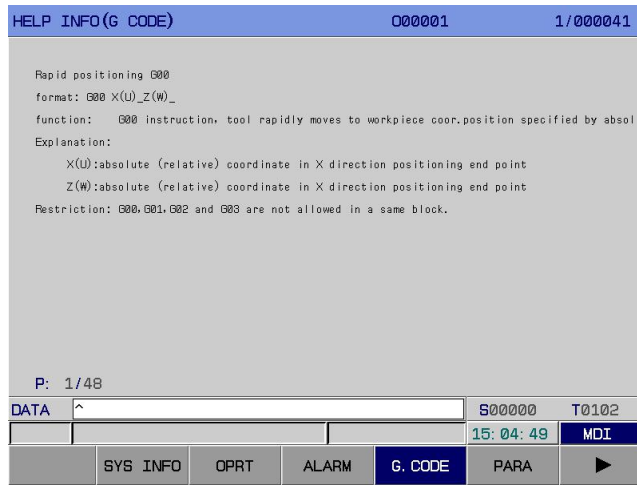

Fig.3-9-5

This interface introduces the format, function, description, and restriction of code in detail. On this interface, one that is unfamiliar with or unclear about codes can searched and search and check them.

5. Parameter list interface: On <Help> interface, press [Parameter List] to enter the help information (parameter/diagnosis table) interface, as shown in Fig.3-9-6:

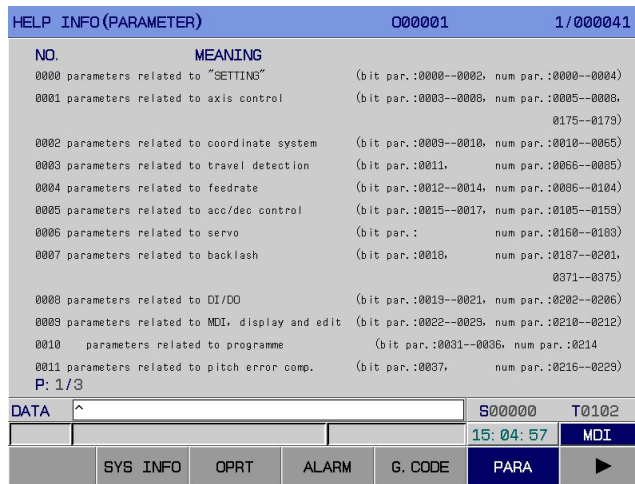



Fig.3-9-6

This interface introduces the parameter setting of each function in detail. One that unfamiliar with or unclear about parameter setting can search and check settings on this interface.

6. Macro command interface: Press  to enter the [Macro Command] help information (macro command table) interface, as shown in Fig.3-9-7:

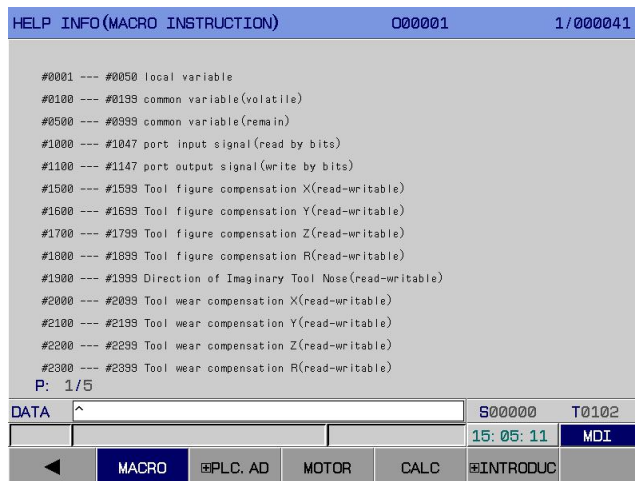

Fig.3-9-7

This interface introduces the format and operation codes of macro commands and provides the setting range of local variable, general variable, and system variable. One that is unfamiliar with or unclear about macro command mathematical operations can search and check related information on this interface.

7. PLC.AD interface: On <Help> interface, press [PLC.AD] to enter the help information (PLC address table) interface. PLC address interface contains 4 sub- interface: [F Signal], [G Signal], [X Signal], [Y signal], as follows (See Fig.3-9-8 ~ 3-9-11).

HELP INFO (PLC ADDRESS)		000001	1/000041
ADDR	SYM	MEAN	
F000#0FWD		Rewinding signal	
F000#4SPL		Feed hold lamp signal	
F000#5STL		Cycle start lamp signal	
F000#6SA		Servo ready signal	
F000#7OP		Automatic operation signal	
F001#0AL		Alarm signal	
F001#1RST		Resetting signal	
F001#3DEN		Distribution completion signal	
F001#4ENB		Spindle enable signal	
F001#5TAP		Tapping signal	
F001#7MA		CNC ready signal	
F002#0INCH		Inch input signal	
F002#1RPDO		Rapid traversing signal	
F002#2CSS		Constant surface speed signal	
P: 1/42			
DATA		^	
		S00000	T0102
		15:05:26	MDI
F ADDR	G ADDR	X ADDR	Y ADDR
		RETURN	

Fig.3-9-8

HELP INFO (PLC ADDRESS)		000001	1/000041
ADDR	SYM	MEAN	
G000#0ED00		Data signal for external data input	
G000#1ED01		Data signal for external data input	
G000#2ED02		Data signal for external data input	
G000#3ED03		Data signal for external data input	
G000#4ED04		Data signal for external data input	
G000#5ED05		Data signal for external data input	
G000#6ED06		Data signal for external data input	
G000#7ED07		Data signal for external data input	
G001#0ED08		Data signal for external data input	
G001#1ED09		Data signal for external data input	
G001#2ED10		Data signal for external data input	
G001#3ED11		Data signal for external data input	
G001#4ED12		Data signal for external data input	
G001#5ED13		Data signal for external data input	
P: 1/55			
DATA		^	
		S00000	T0102
		15:05:37	MDI
F ADDR	G ADDR	X ADDR	Y ADDR
		RETURN	

Fig.3-9-9

HELP INFO (PLC ADDRESS)		000001	1/000041
ADDR	SYM	MEAN	
X020#0		MT-EDIT	
X020#1		MT-AUTO	
X020#2		MT-INPUT	
X020#3		MT-ZERO	
X020#4		MT-SINGLE STEP	
X020#5		MT-MANUAL	
X020#6		MT-HANDWHEEL	
X020#7		MT-DNC	
X021#0		MT-SKIP	
X021#1		MT-SINGLE BLOCK	
X021#2		MT-DRY RUN	
X021#3		MT-MST LOCK	
X021#4		MT-MACHINE LOCK	
X021#5		MT-OPTIONAL HALT	
P: 1/ 5			
DATA		^	
		S00000	T0102
		15:06:00	MDI
F ADDR	G ADDR	X ADDR	Y ADDR
		RETURN	

Fig.3-9-10

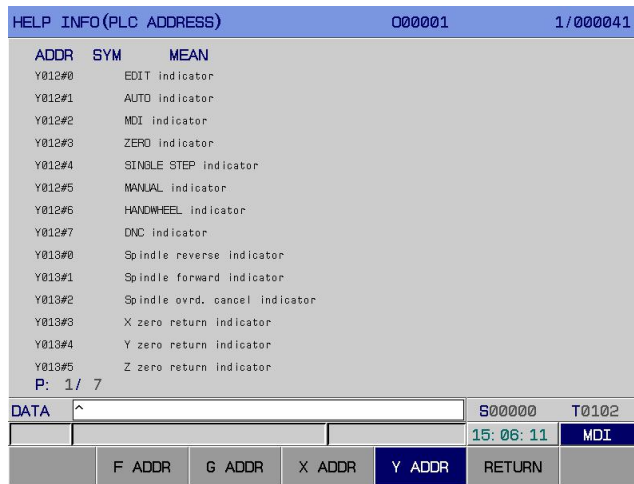

Fig.3-9-11

PLC address interface introduces PLC address, symbol, significance in detail. One that is unfamiliar with or unclear about PLC address can search and check related information on this interface.

8. Motor table interface: On <Help> interface, press [Motor Table] to enter the motor table interface, as shown in Fig.3-9-12:

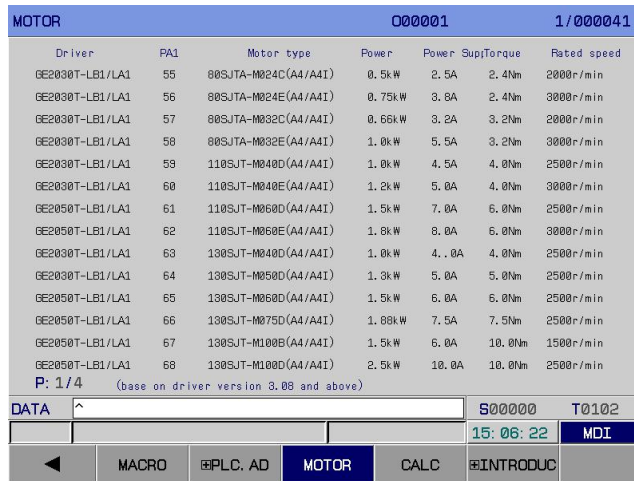

Fig.3-9-12

9. Calculator interface: On <Help> interface, press [Calculator] to enter the calculator interface, as shown in Fig.3-9-13

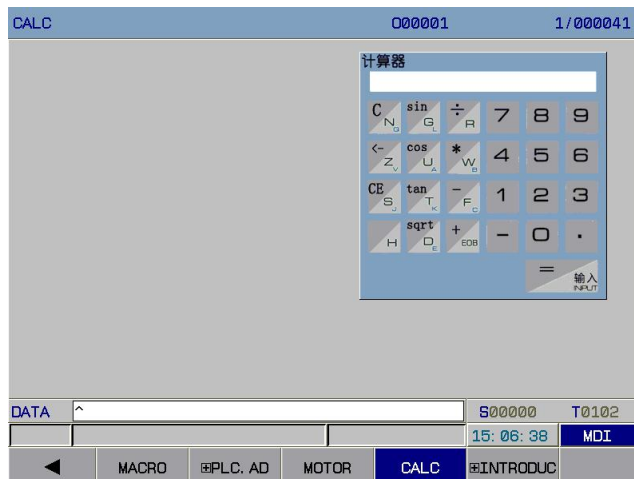

Fig.3-9-13

On this interface, system gives the operation formats of addition, subtraction, multiplication, division, sine, cosine, and radication. Input the required value through number keys and press <MDI>. System will compute the result automatically. If it is required to input data again for computation, press



to clear all data on the interface.

Chapter 4 Manual Operation



Press **MANUAL** to enter the manual operation mode, including manual feed, spindle control, and machine tool panel control.

4.1 Motion of Coordinate Axis

In manual operation mode, an axis can move at manual feed speed or manual fast motion speed.

4.1.1 Manual feed



In <manual mode>, hold the feed axis **X-axis** or **Z-axis** and corresponding axis starts moving. Its movement speed may vary with the adjustment of feed magnification. Once the key is released, axis movement stops. The same goes for **Z-axis**. This system supports the simultaneous movement of two axes or the simultaneous zero returning of all axes.

Note: The manual feed speed of each axis is set through P98.

4.1.2 Manual fast motion



Turn on the indicator light by pressing **RAPID**, and system enters manual fast motion state. Then, press the axis key in feed direction and each axis moves at the speed of fast motion.

Note 1: The speed of manual fast motion is set through P170~ P173.

Note 2: Whether manual fast motion is effective or not before an axis returns to the reference point through Bit Para NO:12#0.

4.1.3 Speed selection for manual feed and manual fast motion

In the case of manual feed, it is allowed to select the manual feed magnification from 21 levels (0%~200%), through keys on operation panel.

In the case of manual fast motion, it is allowed to select the magnification of manual fast motion



speed from 4 levels (F0, 25%, 50%, 100%) through **F0**, **25%**, **50%**, **100%**. (F0 speed is set through Num Para P93).

Note: The selection of rapid magnification is valid for the following movement speeds.

- (1) G00 rapid feed (2) rapid feed in fixed cycle
- (3) G28 rapid feed (4) rapid feed in manual mode

For example, given that the rapid feed speed is 6 m/min, the speed is 3 m/min if magnification is 50%.

4.1.4 Manual intervention

If a program operating in automatic mode or in MDI mode is switched to manual mode after feed hold, manual intervention is allowed. Move all axes, and switch the operation mode to original one. If the



program movement starts through , each axis returns to original manual intervention point rapidly in G00 mode before continuous movement.

Detailed explanation:

1. If a single block is connected during returning, the tool will perform single-block pause at manual intervention point.
2. In the case of an alarm or resetting during manual intervention or returning, this function will be canceled.
3. In the case of manual intervention, be careful with the functions of machine tool such as lock, mirror, and scaling.
4. During manual intervention, pay attention to the machining process and workpiece shape, so as to protect tool or machine tool from being damaged.

Actions for manual intervention is shown below:

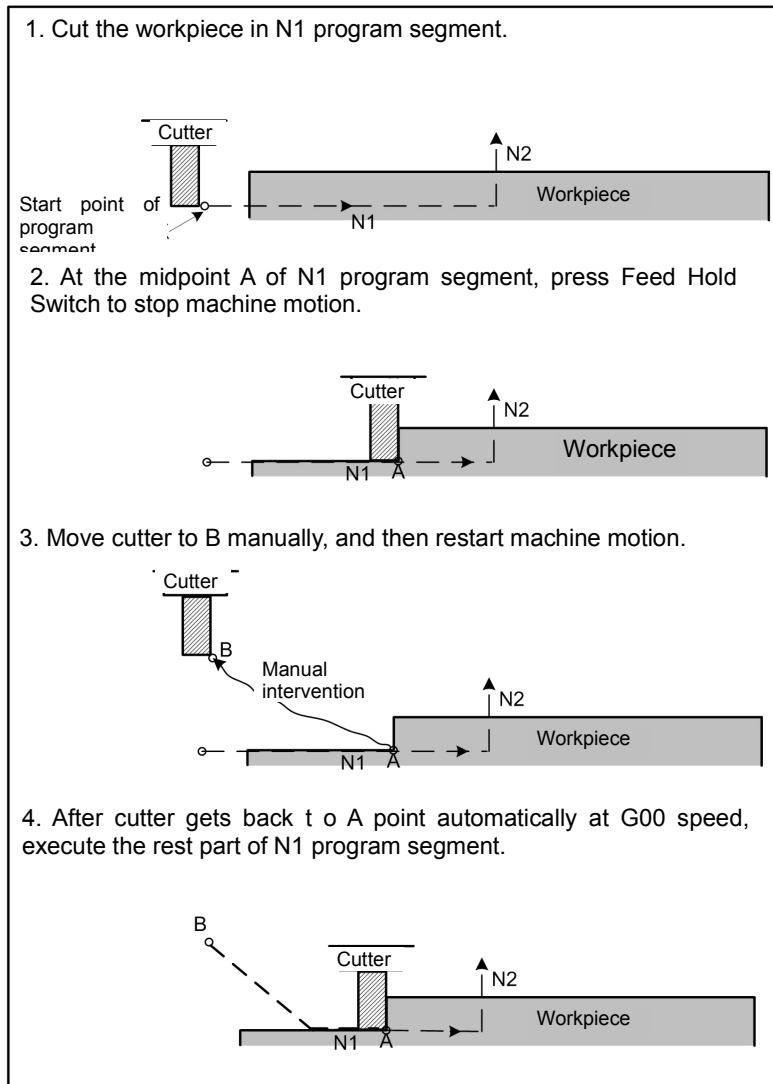

Fig.4-1-4-1

4.2 Spindle Control

4.2.1 Counter-clockwise rotation of spindle



: If S speed is given in MDI mode, spindle rotates counterclockwise after this key is pressed in manual/manual pulse/single-step mode.

4.2.2 Clockwise rotation of spindle



: If S speed is given in MDI mode, spindle rotates clockwise after this key is pressed in manual/manual pulse/single-step mode.

4.2.3 Spindle stop



: Spindle stops rotation after this key is pressed in manual/manual pulse/single-step mode.

4.2.4 Automatic gear shifting of spindle

Select variable-frequency control or I/O point control of spindle through Bit Para NO:1#2. When NO:1#2=0, spindle realizes automatic gear shifting with its speed controlled by S speed command. At present, system has three gears and corresponding maximum speeds are set through different parameters (P246, P247, P248) respectively. When NO:1#2=1, the gear of spindle speed is shifted automatically under I/O point control. At present, system has three gears (S1, S2, S3), and it is allowed to modify the ladder graph to increase the gear output. After executing S speed according to the command, system will select corresponding gear automatically.

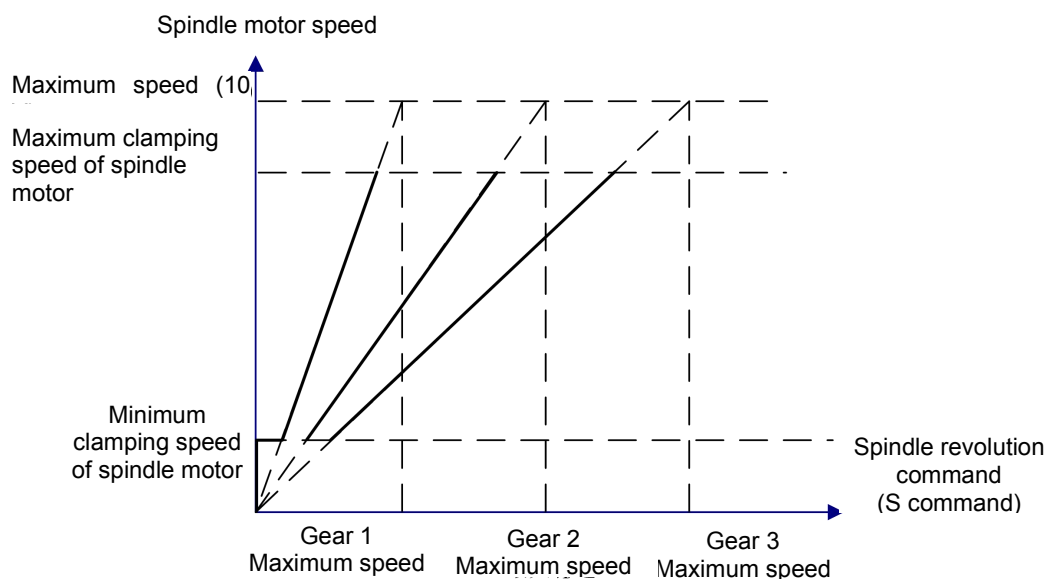

Fig.4-2-4-1

Note: If automatic gear shifting control is effective, system detects the spindle gear and executes S code via gear shifting in-place signal.

4.3 Other Manual Operations

4.3.1 Coolant control



: Coolant switches on and off. It switches on when its indicator light is on; it switches off when its indicator light is off.

4.3.2 Lubrication control



: Lubrication is on when this lubrication key is held or when corresponding indicator light is on; it is off when this key is released or when corresponding indicator light is off.

4.3.3 Chuck control



: In manual mode, push foot switch to release the chuck. It is displayed on [position] interface that chuck is released. Push foot switch again to lock chuck. It is displayed on [position] interface that chuck is locked.

4.3.4 Tailstock control



: The machine tool tailstock switches between forward / backward. It goes forward when corresponding indicator light is on; it goes backward when corresponding indicator light is off.

4.3.5 Manual tool changing control



: In manual/manual pulse/single-step mode, press this key and the tool rest will rotate to next tool. The total number of tool places can be viewed on [DATA] interface, which is entered through [+ladder graph parameter] under <ladder graph >. (Refer to the machine manufacturer's specification)

4.4 Tool Setting Operation

Generally, machining of one part requires the use of different cutters. Due to installation and deviation, the nose of a tool rotating to the cutting position cannot coincide with that of another tool completely. In order to neglect deviation between cutters in programming, this system sets the tool setting method that is generated by tool bias automatically to simplify the tool setting operation. After tool

setting operation, the user can edit programs according to part drawings and machining process without considering the deviation between tools. What the user needs to do is calling corresponding tool compensation value. This system sets many modes, including tool setting through trial cutting and tool setting for machine tool zeroing.

4.4.1 Fixed-point tool setting

During bias setting on **OFFSET** interface, if only the address key U(or W) is typed before the **INPUT**, then current relative coordinate is set as the bias corresponding to that address.

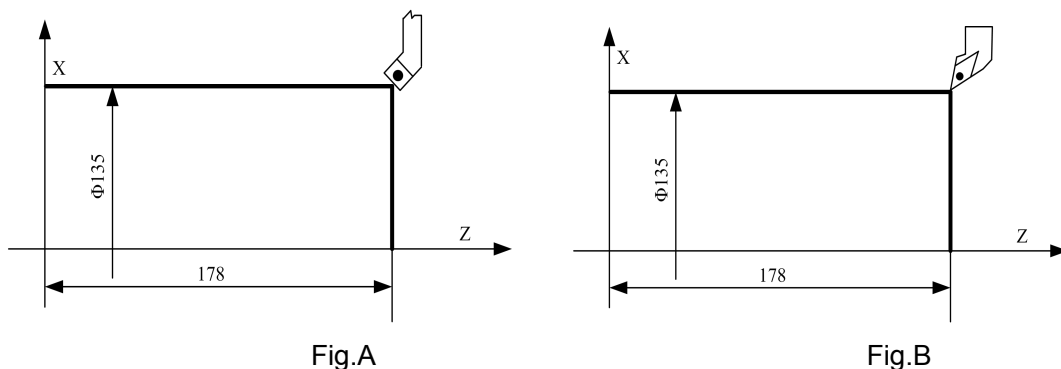



Fig.4-4-1-1

Before fixed-point tool setting, it is required to establish a workpiece coordinate system.

The operation procedure is given below:

- 1) Select any tool, without an offset (generally the first tool in machining) as the benchmark tool;
- 2) Locate the nose of benchmark tool at some point on workpiece (tool setting point), as shown in Fig.A;
- 3) Clear relative coordinate (U, W) so that its value is zero (See 3.1.1 for details);



4) Press **OFFSET** followed by  and/or  to move cursor. Select a bias number as the bias number of benchmark tool. First, verify whether the offsets in X and Z directions are zero. If not, clear them as stated below:

Move cursor to select No.001 ~ 099 tool biases. Input X0 and Z0 to clear the offsets separately.

5) After the tool is moved to a safe position, select another tool and move it to the tool setting point, as shown in Fig.B;

6) Press **OFFSET** and move cursor to select a bias number from 001 ~ 099 as the bias number of that tool. Verify whether the offsets in X and Z directions are zero. If not, clear them as stated in 4) above;

7) Press the address key  followed by , and the offset in X direction will be placed behind corresponding bias number;

8) Press the address key  followed by , and the offset in Z direction will be placed behind corresponding bias number;

9) Repeat steps 5) ~ 8) to complete the offset setting of other cutters.

4.4.2 Tool setting through trial cutting

Where the workpiece coordinate system does not change, tool setting can be conducted through trial cutting. The operation procedure is given below (workpiece end face taken as coordinate system).

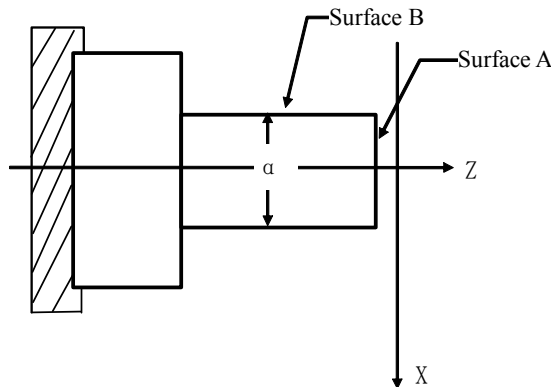









Fig.4-4-2-1

- 1、 Select any tool (supposing it is No.1 tool), without an offset;
- 2、 Cut A surface in the negative X-axis in manual mode;
- 3、 When Z-axis does not move, press “positive X-axis” to release tool and stop spindle rotation;

4、 Press  to enter the bias display interface. Move cursor through  and/or  to select No.1 bias number as the bias number of that tool;

- 5、 Type address key “Z”, number key “0” and  successively;
- 6、 In manual mode, press “negative Z-axis” to cut the workpiece along B surface;
- 7、 When X-axis does not move, press “positive Z-axis” to release tool and stop spindle rotation;
- 8、 Measure the diameter "α" (supposing α'=30);

9、 Press  to enter the bias display interface. Move cursor through  and/or  to select No.1 bias number;

- 10、 Type address key “X”, number keys “3” and “0”, and **INPUT** successively;
- 11、 Move tool to the safe tool changing position;
- 12、 Replace the tool by another tool (supposing it is No.2 tool), without an offset;

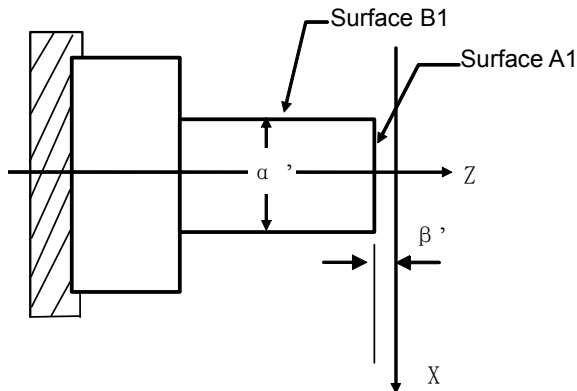





Fig.4-4-2-2

- 13、 In manual mode, press “negative X-axis” to cut the workpiece along A1 surface.
- 14、 When Z-axis does not move, press “positive X-axis” to release tool and stop spindle rotation and stop spindle rotation.
- 15、 Measure the distance “ β ” between A1 surface and workpiece coordinate system “ β ” supposing $\beta=1$).

- 16、 Press **OFFSET** to enter the bias page. Move cursor through  and/or  to select No.2 bias number.

- 17、 Type address key “Z”, symbolic key “-”, number key “1”, and **INPUT** successively.
- 18、 In manual mode, press “negative Z-axis” to cut the workpiece along B1 surface.
- 19、 When X-axis does not move, press “positive Z-axis” to take out tool and stop spindle rotation.
- 20、 The measured diameter “ α ” is supposed to be $\alpha'=28$).

- 21、 Press **OFFSET** to enter the bias page. Move cursor through  and/or  to select No.2 bias number.

- 22、 Type address key “X”, number keys “2” and “8”, and **INPUT** successively.
- 23、 For the tool setting of other cutters, repeat 11 ~ 22.

4.4.3 Tool setting of machine zero return

With this tool setting method, tools are not all the same, not containing benchmark tool. In the case of tool abrasion or adjustment of any tool, what the user need is to conduct tool setting again. Tool setting follows machine tool zeroing (For machine zero point, please see 9.1 of this manual). Once

energized after power-off, the machine is required to return to its zero point before continuous machining, which is simple and convenient.

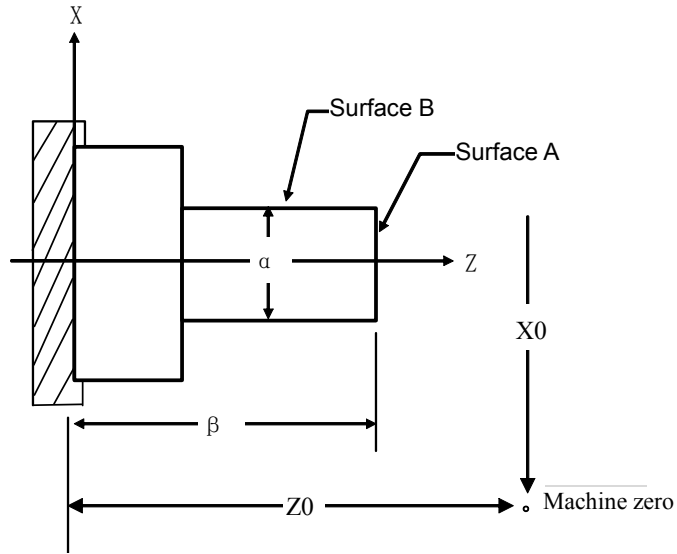



Fig.4-4-3-1

The operation procedure is given below:



- 1) Press  to enter the operation mode of machine tool zeroing. Then, press “positive X-axis” followed by “positive Z-axis” to get these two axes to the machine zero point once;

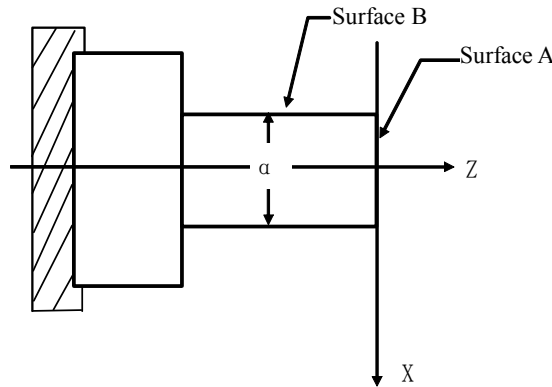
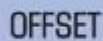





Fig.4-4-2-2

- 2) Select any tool (supposing it is No.1 tool), without an offset;
- 3) In manual mode, press “negative X-axis” to cut the workpiece along A surface;
- 4) In the situation where Z-axis does not move, release tool along the positive X-axis and stop spindle rotation;





OFFSET

- 5) Press  to enter the bias page. Move cursor through  and/or  to select No.1 bias number as the bias number of that tool;

INPUT

- 6) Type the address key “Z”, number key “0”, and  successively;
- 7) In manual mode, press “negative Z-axis” to cut the workpiece along B surface;

- 8) In the situation where X-axis does not move, release tool along the positive Z-axis and stop spindle rotation;
 9) The measured diameter " α " is supposed to be $\alpha'=30$);

- 10) Press **OFFSET** to enter the bias page. Move cursor through  and/or  to select No.1 bias number to enter the bias page. Move cursor through  and/or  to select No.1 bias number;

- 11) Type the address key "X", number keys "3" and "0", and **INPUT** successively;
 12) Move tool to the safe tool changing position;
 13) Replace the tool by another tool (supposing it is No.2 tool), without an offset;

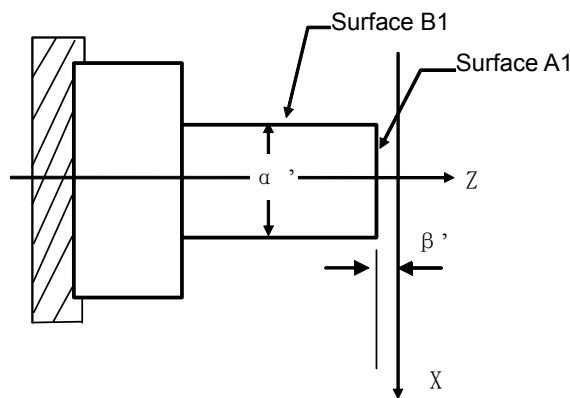





Fig.4-4-3-3

- 14) In manual mode, press negative X-axis to cut the workpiece along A1 surface;
 15) In the situation where Z-axis does not move, release tool along positive X-axis and stop spindle rotation;
 16) Measure the distance between A1 surface and workpiece coordinate system (supposing $\beta'=1$);

- 17) Press **OFFSET** to enter the bias page. Move cursor through  and/or  to select No.2 bias number;

- 18) Type the address key "Z", symbolic key "-", number key "1", and **INPUT** successively.
 19) In manual mode, press "negative Z-axis" to cut the workpiece along B1 surface;
 20) In the situation where X-axis does not move, withdraw tool along positive Z-axis and stop spindle rotation;
 21) Measure the diameter " α " (supposing $\alpha'=28$);

- 22) Press **OFFSET** to enter the bias page. Move cursor through  and/or  to select No.2 bias number;

INPUT

23) Type the address key “X”, number keys “2” and “8”, and

24) For the tool setting method of other cutters, repeat 12~23.

4.5 Adjustment of Compensation Values

During modification and adjustment, offsets can only be inputted through U and W. For example, the

OFFSET

offset on X-axis need be increased by 0.010mm. Press

through



and/or



to select some bias number behind 001. Input U0.010 and then

press

. The system will add 0.010 mm automatically to original offset.

Chapter 5 Single-Step Operations





5.1 Single-Step Feed



When PLC K parameter K017#1 is set to 1(1: single-step mode), press  to enter the single-step mode. In this mode, machine moves a distance equal to the selected step length at a time.

5.1.1 Amounts of movement selection



Press any of     keys to select a movement increment, which is displayed on the page. For example, press F0% and <position> interface will display the single-step step length: 0.0001. (See Fig.5-1-1-1)

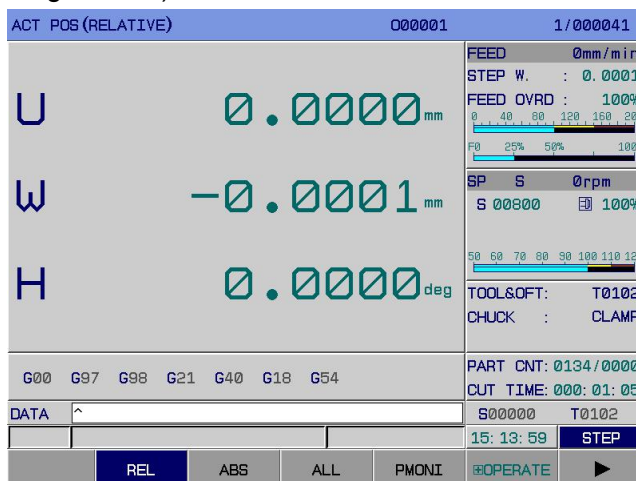



Fig.5-1-1-1

Every time a movement key is pressed, corresponding axis of machine tool moves 0.1 mm.

5.1.2 Selection of shifting axis and movement direction



Press the direction key  or  of feed axis. Arrow keys of **X-axis** can make **X-axis** move in the positive or negative direction. Every time a key is pressed, corresponding axis moves a distance that the system defines for a single step; the same goes for **Z-axis**. This system supports both simultaneous movement and simultaneous zeroing of two axes.

5.1.3 Specification for single-step feed

The maximum clamping speed of single-step feed is set through Num Para P155. The single-step feed speed is not controlled by feed magnification or rapid magnification.

5.2 Auxiliary Control during Single-Step Operations

The same as manual operation mode, see 4.2 and 4.3 of this manual for details.

Chapter 6 Manual Pulse Operations



When PLC K parameter K017#1 is set to 0 (0: manual pulse mode), press  to enter the manual pulse mode. In this mode, machine tool moves a distance equal to selected step length at a time.

6.1 Manual Pulse Feed



Press any of  keys to select a movement increment, which is displayed on the page. For example, press 25% and <position> interface will display the manual pulse increment: 0.0010. (See Fig.6-1-1):

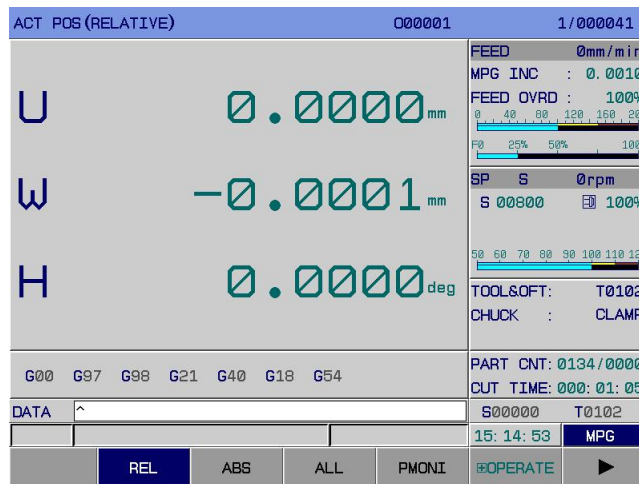
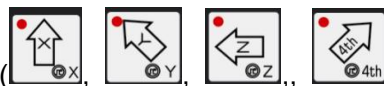







Fig.6-1-1

6.1.1 Selection of shifting axis and movement direction

In manual pulse mode, select the shifting axis to be controlled by manual pulse and press



corresponding key (, , , ). Then, the selected axis will move under manual

pulse control. Taking X-axis under manual pulse control for example, after  is pressed, its light flickers. At this time, the user can move X-axis through manual pulse. Generally speaking, the clockwise rotation of manual pulse is in the positive direction of feed axis, and counter-clockwise rotation of manual pulse is in the negative direction.

The feed direction under control of manual pulse (manual pulse generator) is determined by the manual pulse rotation direction. See the machine manufacturer's specification for details. Generally speaking, clockwise rotation under manual pulse control is the positive feed direction; counter-clockwise rotation is the negative feed direction.

6.1.2 Specification for manual pulse feed

1. The relationship of manual pulse scales with machine tool shift is given below:

Table 6-1-2-1

	Shift at each scale in manual pulse mode		
Manual pulse increment (mm)	0.001	0.01	0.1
Machine shift (mm)	0.001	0.01	0.1
Manual pulse increment (inch)	0.001	0.01	0.1
Machine shift (inch)	0.0001	0.001	0.01

2. Data listed above vary with different mechanical transmission. See the machine manufacturer's specification for details;





3. When Bit Para No.17#5 is set to 1, the selection of handing-pulse shift starts. The manual pulse rotating speed cannot exceed 5 r/s. If it exceeds, there might be a phenomenon a scale does not match the shift.

6.2 Control during Manual Pulse Interruption

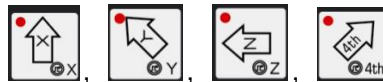
6.2.1 Manual pulse interruption

In automatic mode and MDI mode, press [comprehensive] on [position] interface to enter the comprehensive interface. Press [operation] followed by [interruption switch]. Select the manual pulse axis number on panel to enter the state of manual pulse interruption for interruption operations. Press [interruption switch] again to exit manual pulse.



In the state of manual pulse interruption, press , , ,  to select the axis. When the manual-pulse interruption selection signal of some axis is "1", this axis can be interrupted in manual pulse mode. The equivalent of manual pulse interruption is equal to that of manual pulse feed.

The speed at the time of manual pulse interruption is the sum of automatic operation speed and speed in manual pulse interruption. However, its stacking velocity should not go beyond the maximum speed of cutting & feeding of that axis. For example, given that the maximum manual pulse speed is 2,000 mm/min, if the current feeding speed is 2,000 mm/min, then the speed range of manual pulse interruption is 4,000 ~ 0 mm/min (the minus represents the manual-pulse interruption moving direction is opposite to the feeding direction)

(For the coordinate system of manual pulse interruption, see Fig.6-2-1-2.)

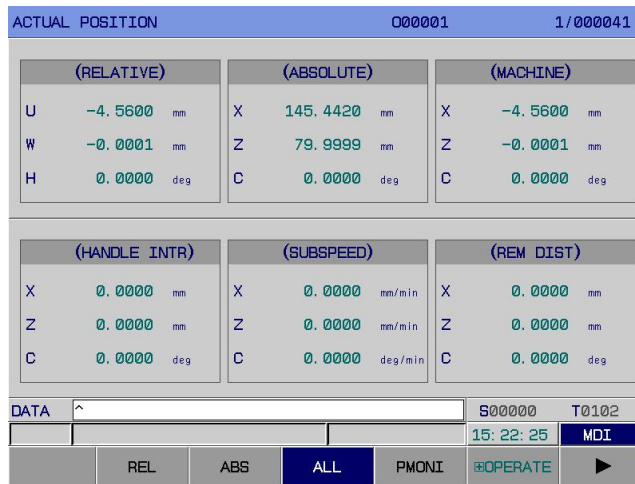



Fig.6-2-1-2

Operation procedures for manual pulse interruption and coordinate system zeroing: Press . Move cursor downwards until the X-axis of coordinate system of manual pulse interruption flickers.



Press  to clear the coordinate system. The same goes for Z-axis. While executing zeroing, the coordinate system will also be cleared automatically.

Note: If an alarm or resetting occurs during the adjustment of coordinate system based on manual pulse interruption, the manual pulse interruption function is canceled.

6.2.2 Relationship of manual pulse interruption with other functions

When manual pulse interruption makes an axis move, the actual position of shifting axis changes and the coordinate of machine tool is updated, but its absolute coordinate is not updated. Therefore, after manual pulse interruption, the trailer moves. Then, the machine coordinate system will keep still, while the workpiece coordinate system will shift.

Table 6-2-2-1

Display	Relationship
machine tool latching	Once machine tool latching is enabled, the moving trailer in manual pulse interruption is invalid.
absolute coordinate value	The change in absolute coordinate value is the displacement resulting from manual pulse interruption.
relative coordinate value	The change in relative coordinate value is the displacement resulting from manual pulse interruption.
Machine coordinate value	The change in machine coordinate value is the displacement resulting from manual pulse rotation.

Note: When axes return to reference points manually, the shift in manual pulse interruption is cleared.

6.2.3 Cancellation of manual pulse interruption

Cancellation of interruption means that through manual pulse interruption the workpiece coordinate system shifting from machine coordinate system returns to the position before shifting.

When interruption is canceled, the workpiece coordinate system shifts a distance equal to manual pulse interruption and reflects manual pulse interruption in absolute coordinate.

The shift of workpiece coordinate system resulting from manual pulse interruption is shown below:

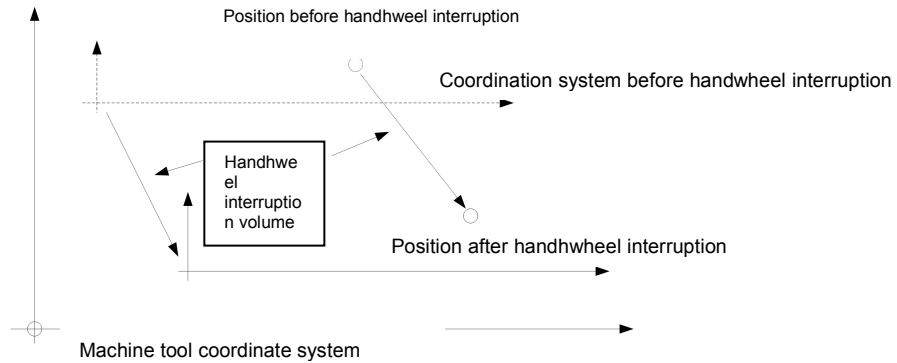

When manual pulse interruption is canceled, the workpiece coordinate system restores to the state before interruption, without any change in actual position, which are shown below:

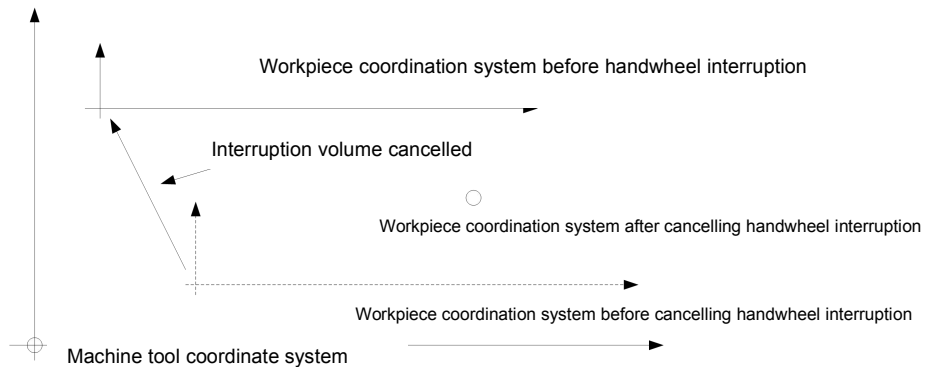

In any of the following cases, it is allowed to cancel interruption:

- Coordinate axes returns to reference points in manual mode.
- G28 command is specified before a reference point is determined.
- An interruption quantity is cleared through [interruption clear].

6.3 Auxiliary Control during Manual Pulse Operations

The same as manual operation mode, see 4.2 and 4.3 of operating instructions.

6.4 Manual Pulse Trial Cutting

Part programs are controlled through manual turning of manual pulse, and the machine is operated along the tool path instructed by machine program. Mostly, this function is used for trial cutting of workpiece and detection of machine program.

Operation method:

In automatic mode, open manual pulse trial cutting. After  is pressed, any axis of system stops moving. In this case, turn manual pulses to control the operation of part program. The faster manual pulses turn, the faster the program executes an command. The slower manual pulses turn, the slower the program executes an command. The shift of each manual pulse can be adjusted through rapid magnification.



In manual pulse trial cutting mode, if  is pressed again, the operation mode returns to automatic mode. All operations in manual pulse test cutting mode are the same as in automatic mode.

Speeds at which the interpolation command is executed in the state of manual pulse trial cutting.

G0: current rapid magnification × manual pulse magnification × manual pulse speed

G1: cutting magnification × manual pulse magnification × manual pulse speed

Note 1: Effective after manual pulse trial cutting is enabled.

Note 2: Effective for single-block pause in single-block mode.

Chapter 7 Automatic Operations

7.1 Selection of Automatic Running Program

1. Automatic mode loading program

(a) Press  to enter the automatic operation mode;

(b) Press  to enter the [catalog] page. Move cursor to find the target program;

(c) Press  for confirmation.

2. Editing mode loading program

(a) Press  to enter the editing operation mode;

(b) Press  to enter the [catalog] page. Move cursor to find the target program;

(c) Press  for confirmation.



(d) Press  to enter the automatic operation mode;

7.2 Initiation of Automatic Running

After selection of the program to be initiated with two methods stated in 7.1, press  (circulation start-up) to start automatic running. It is allowed to switch to <position>, <program monitoring>, or <graph> interface to observe program running.

Since program running starts from the line of cursor, it is better to check whether cursor is located on

the program line or not and whether modal values are correct or not before pressing  (circulation start-up). If automatic running need start from the start line, where cursor is not located, it

is required to press  followed by  (circulation start-up).

Note: During program running in automatic mode, it is not allowed to modify the workpiece coordinate system or basic bias.

7.3 Stop of Automatic Running

To stop the program in automatic running, system provides 5 methods:



1. Program stops (M00)

When executing the block with M00, the program pauses, with modal information stored. After

 (circulation start-up) is pressed, the program continues execution.

2. Program selection stops (M01)



If  is pressed before program running, the program pauses when executing the block containing M01, with modal information stored. After  (circulation start-up) is pressed, the program continues execution.

3. Press  (feed hold)

During automatic running, after  (feed hold) is pressed the machine tool presents the following states:

- 1) Machine tool feeding slows down to stop;
- 2) When execution pauses (G04 code), timing stops and the machine goes into the state of feed hold;
- 3) Other modal information is stored;
- 4) After  (circulation start-up) is pressed, the program continues execution.

4. Press .

See 2.3.1 of *Operating Instructions*.

5. Press EMERGENCY STOP.

See 2.3.2 of *Operating Instructions*.



In addition, a program running on MDI interface in automatic mode or in MDI mode can also stop if it is switched to another mode. Particular cases are given below:

- 1) The machine stops after running current block, if switched to editing or input interface.
- 2) The machine stops immediately, interrupting current operation, if switched to an interface in manual, manual pulse, or single-step mode.
- 3) The machine slows down to stop if switched to the mechanical zero return interface.

7.4 Automatic Running from Any Block

The system supports automatic running from any block of current machine program. Its operation procedure is detailed below:

- 1、 Press  to enter the manual mode. Initiate the spindle and other miscellaneous functions;
- 2、 Run modal values of the program in MDI mode. It is required to ensure all modal values are correct;

- 3、 Press  to enter the editing operation mode. Press  to enter the program page. Find the program to be machined in [catalog];

- 4、 Open the program. Move cursor to the block to be run;

- 5、 Press  to enter the automatic operation mode;



6. Press  (circulation start-up) to start automatic running.

Note 1. Before program running, it is required to confirm the current coordinate is where last block stops running (If the running block is G00/G01 movement in absolute programming, confirmation is not required).

Note 2. If the running block is such movement as tool changing, it is required to confirm previously that the current position will not collide with the workpiece, in case of machine damage and fatal accident.

7.5 Dry Running

Before program machining, it is allowed to adopt “dry running”, generally in combination with “auxiliary lock” and “machine lock”, to check the program.



Press  to enter the automatic operation mode. Press



 (That the indicator light is on this key means the state of dry running).).

: program speed in rapid feed = dry running speed × rapid feed magnification.

: actual cutting speed of program screw thread in cutting feed = $F \cdot S$ (S is a programming value) F/S is the current mode.

Note 1: The dry running speed is set through Num Para P86;

Note 2: Whether dry running is valid or not during cutting feed is set through Bit Para NO:12#6;

Note 3: Whether dry running is valid or not in rapid positioning is set through Bit Para NO:12#7.

7.6 Single-Block Running

Select “program single block” running for detection of program single-block running.



In automatic and MDI mode, press  (That the indicator light is on this key means the state of dry running). During single-block running, the system stops running every time it finishes the

execution of one block. Press  (circulation start-up) to continue executing next block. Repeat this process until the program finishes running.

Note 1: In G28, single block stop is all the same at the midpoint.

Note 2: When the single-block program is ON, execute fixed cycles G90, G92, G70—G75 as follows:

Table 7-6-1

G Code	Tool Path	Explanation
G90		<p>Actions 1 ~ 4 form a cycle. The program stops running at the end of Action 4.</p>
G92		<p>Actions 1 ~ 4 form a cycle. The program stops running at the end of Action 4.</p>
G94		<p>Actions 1 ~ 4 form a cycle. The program stops running at the end of Action 4.</p>
G70		<p>Actions 1 ~ 7 form a cycle. The program stops running at the end of Motion 7.</p>
G71, G72	<p>Note: This figure shows the case of G71, the same as G72.</p>	<p>1 ~ 4, 5 ~ 8, 9 ~ 12, 13 ~ 16, and 17 ~ 20 form a cycle. The program stops running at the end of cycle.</p>
G73		<p>Actions 1 ~ 6 form a cycle. The program stops running at the end of cycle.</p>

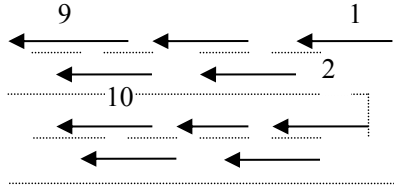
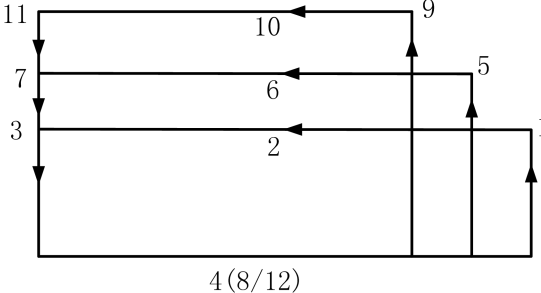
G Code	Tool Path	Explanation
G74, G75		Actions 1 ~ 10 form a cycle. The program stops running at the end of cycle.
G76		Actions 1 ~ 4, 5 ~ 8, and 9 ~ 12 form a cycle. The program stops running at the end of cycle.

7.7 Locked Running of Machine



In **<automatic>** mode, press **MACHINE LOCK** (The indicator lighting up means the machine is locked). Now, any axis of machine does not move but its position coordinate displayed as if the machine were moving. Besides, **M**, **S**, and **T** can be executed. This function is used for program checking.

7.8 Locked Running of Miscellaneous Functions



In **<automatic>** mode, press **MST M.S.T. LOCK** (The indicator lighting up means the miscellaneous function is locked). In this case, **M**, **S**, or **T** code is not executed. This function is used for program checking together with locked running of machine.

Note: M00, M01, M02, M30, M98, and M99 are executed as usual.

7.9 Adjustment of Feed and Fast Motion Speeds in Automatic Running

In **<automatic>** running, the system can change the movement speed by adjusting the magnification of feed and fast motion.

In automatic running, the user can select the fast motion speed and rapid magnification through



to realize the adjustment of four levels: F0, 25%, 50%, 100%.

In automatic running, the user can also select the feed speed and feed magnification through



to realize the real-time adjustment of 21 levels.

Note 1: F setting in feed magnification adjustment program

Actual feed speed = F setting × feed magnification



Note 2: The fast motion speed is obtained through adjustment of number parameters P88, P89, P90 and fast magnification:

Actual fast motion speed on X-axis = P88 setting × fast magnification

The actual fast motion speed on Z-axis is calculated in the same way.

7.10 Adjustment of Spindle Speed in Automatic Running

In automatic running, the spindle speed can be adjusted if it is controlled by an analog quantity.

In automatic running, the user can adjust the spindle magnification, through  or , to change the spindle speed and spindle magnification, so as to realize the real-time adjustment of 8 levels within **50% ~ 120%**.

The speed magnification increases by one level every time  is pressed, and each level is 10%. The magnification will not increase any more if it reaches 120%;

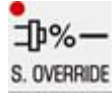
The speed magnification decreases by one level every time  is pressed, and each level is 10%. The magnification will not increase any more if it reaches 50%.

7.11 Back-End Editing in Automatic Running

The system supports back-end editing during processing.

When the program runs in automatic mode, press <program > to enter the program display interface, and then press [program] to enter the back-end editing interface, as shown in **Fig.7-11-1**:



Fig.7-11-1

Press [B. Edit] to enter the program back-end editing interface. The program is edited as same as in editing mode. See Chapter 10 *Program Editing Operations* for details. Press [B. End] to save the edited program before exiting.

In automatic mode, press [debugging] to check the program.

Note 1: The file to be edited at back end should have maximum 3,000 lines, or it will influence the processing effect.

Note 2: For back-end editing, a front-end program can be opened but cannot be edited or deleted.

Note 3: For back-end editing, a running front-end program cannot be edited.

Chapter 8 MDI Operations

In MDI mode, the system supports input and modification of parameters and biases, and also provides MDI running function, through which it is allowed to input codes directly. Data input and modification of parameters and biases are detailed in Chapter 3 *Interface Display and Data Modification & Setting*. This chapter introduces the **MDI** running function among input operations.

8.1 Input of Code Segment in MDI

Input in MDI mode:

1. **[MDI]** supports continuous input of multiple blocks;

Input in [MDI] mode is shown below (See Fig.8-1-1), the same as program input in editing mode. See Chapter 10 *Program Editing Operations* for details.



Fig.8-1-1

8.2 Running and Stop of Code Segment in MDI

After inputting code segments as stated in 8.1, press  (circulation start-up) to start **MDI**

running. During running, it is allowed to press  (feed hold) to stop code segment running.

Note 1: MDI running can only be conducted in MDI mode!

Note 2: It is allowed to input maximum 65 characters once.

Note 3: The maximum block that MDI program can edit is 1W.

8.3 Modification and Clearing of Code Segment Field Value in MDI

If there is a mistake in field input, the user can press  to cancel input; if a mistake is found

after input, the user can either replace the wrong character by correct one or delete all characters by



pressing and input character again.

8.4 Switching of Running Modes

If a running program switches from automatic or MDI mode to MDI, automatic, or editing mode, the system will stop program running after the end of current block.

If a running program pauses for a while before switching from automatic or MDI mode to manual pulse mode, the system executes the function of manual pulse interruption. See 6.2 *Manual Pulse Interruption* of this manual. If it switches to manual mode, the system executes the function of manual intervention, as shown in 4.1.4 *Manual Intervention*.

If a running program switches from automatic or MDI mode immediately to single-step, manual pulse, manual, zero return mode, the program slows down to stop.

Chapter 9 Zero Return

9.1 Machine Zero (Mechanical Zero)

The machine coordinate system is a intrinsic coordinate system of machine. Its origin, called mechanical zero (or machine zero) and also called **reference point** in this manual, is the mechanical origin specified by the machine manufacturer and generally mounted at the maximum stroke of **X-axis** and **Z-axis** in positive direction. The CNC device is not at the mechanical origin when energized, so it should return to the mechanical origin automatically or manually.

9.2 Zero Return of Program

Zero return of program is convenient for a programmer to use the workpiece coordinate system (also called part coordinate system) during programming. The programmer selects a point as the program zero (This point is specified through G50 code and called program zero) to establish a workpiece coordinate system.

9.2.1 Procedure for program zero return



1. Press  to enter the program zero return mode. At this point, the lower right corner of LCD screen displays “program zero return”.
2. Select X-axis or Z-axis that need return to program zero.
3. The workbench moves towards program zero. When it returns to program zero, the coordinate axis

stops moving and the zero return indicator  lights up.

Note 1: Once energized, the system must execute G50, or it will give #0097alarm.

Note 2: When the machine lock is valid, execute program zero return, with absolute coordinate returning to G50 setting but mechanical coordinate constant. Please pay attention to that case.

Note 3: After setting Bit Para NO: 6#5 to 0, the user can conduct zero return through program command G28 because the detection stroke baffle block is equivalent to manual mechanical zero return.

9.3 Zero Return Setting of Bus Servo

There are two zero return modes, which are stated below, for system configuration of bus servo: common zero return and absolute zero setting.

9.3.1 Common zero return

Set Bit Para No: **0#0=1**. The system can return to zero in common mode, with or without one revolution of signals. This zero return mode can be used for system configuration of GE2000 series increment mode version. In zero return mode, each axis is valid.

Procedure for mechanical zero return of bus servo:



- (1) Press  to enter the mechanical zero return mode. At this point, the lower right corner of LCD screen displays “mechanical zero return”.

(2) Select X-axis or Z-axis that need return to program zero. The zero return direction is set through Bit Para N0:7#0 ~ N0:7#4。

(3) The machine moves towards mechanical zero fast (The movement speed is set through Num Para P100 ~ P104) before the slowdown point. After it touches the slow-down switch, the movement speed of each axis is set through Num Para P342~P346. After it gets rid of baffle block, the machine moves to mechanical zero (namely reference point) at FL (set through Num Para P099) speed. When the machine returns to mechanical zero, coordinate axes stop moving and the zero return indicator lights up.

Note: Bit para P6.0 is only valid for incremental zero return.

9.3.2 Absolute zero setting and zero return

Absolute zero setting can be conducted on [ Bus Configuration] interface. See 3.3.5 Display, Modification, and Setting of Bus Servo Parameters for details.

For absolute zero return, select the machine zero return mode and press X-axis and Z-axis. At machine zero, the indicator lights up.

Examples:

For absolute encoder zero setting, it is allowed to set the zero according to the absolute position motor feeds back, as shown in Fig.9-3-2-1.

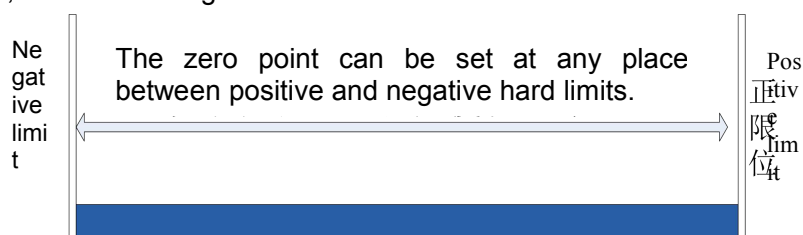

Fig.9-3-2-1 Absolute Encoder Zero Setting

Note 1: If there is not a zero return slowdown switch installed or a mechanical zero set on your machine, please do not operate mechanical zero return.

Note 2: At the end of mechanical zero return, the indicator of corresponding axis lights up.

Note 3: When corresponding axis is not at mechanical zero, the zero return indicator light is out.

Note 4: For mechanical zero (namely reference point) direction, please refer to the machine manufacturer's instructions for use.

Note 5: Do not modify the zero return direction, feed axis direction, or gear ratio of any axis after mechanical zero setting.

Note 6: For parameters related to mechanical zero return and various mechanical zero return modes, see Chapter IV Installation & Connection of *PLC and Installation Booklet*.

Chapter 10 Editing Operations

10.1 Program Editing



A part program should be edited in editing mode. Press to enter the editing mode; press

PROGRAM

on panel to enter the program interface. Press [program] softkey to enter the program editing & modifying interface. (See Fig.10-1-1):



Press [] to enter next page



Press [] to enter next page



Press [] to return to last page



Fig.10-1-1

The program can be replaced, cut, copied, pasted, re-started through corresponding softkeys. Before program editing, it is required to turn on program switch. For operation details, see 3.3.1 in this part.

Note 1: A program file has maximum 10,000 lines.

Note 2: As shown in Fig.10-1-1, when there are more than one “/” at the beginning of a block, the system can skip this block even if the skip function is not opened.

Note 3: During debugging, the system cannot switch from automatic mode to another mode. Otherwise, the consequence will be unexpected.

: Execute debugging in automatic mode. When there is a “/” at the beginning of a block, the program line behind this character will execute debugging even if the skip function is not opened.

10.1.1 Program establishing

10.1.1.1 Automatic generation of sequence number

Set “automatic sequence number” to 1 as stated in 3.3.1 of this part (See Fig.10-1-1-1).

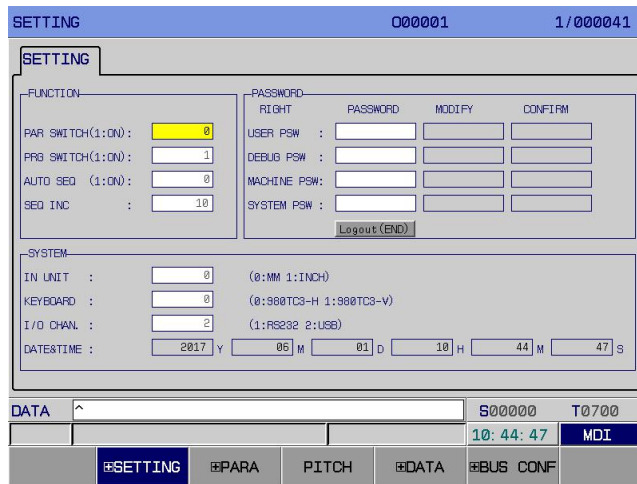



Fig.10-1-1-1

Then, the system will insert sequence numbers automatically between blocks during program editing. The increment in sequence number can be set in sequence number increment.

Note: After insertion of a new block, new S/N= current sequence number increment × (line where this block is - 1).

10.1.1.2 Program content input

1、 Press  to enter the editing mode;

2、 Press  to enter the program page. (See Fig.10-1-1-2-1):

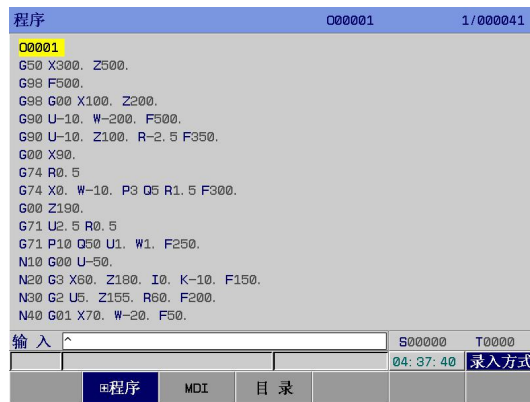







Fig.10-1-1-2-1

3. Press address key  followed by number keys , , , ,  (taking the establishing of O00002 program name for example). O00002 is displayed behind data column, as shown below (See Fig.10-1-1-2-2):

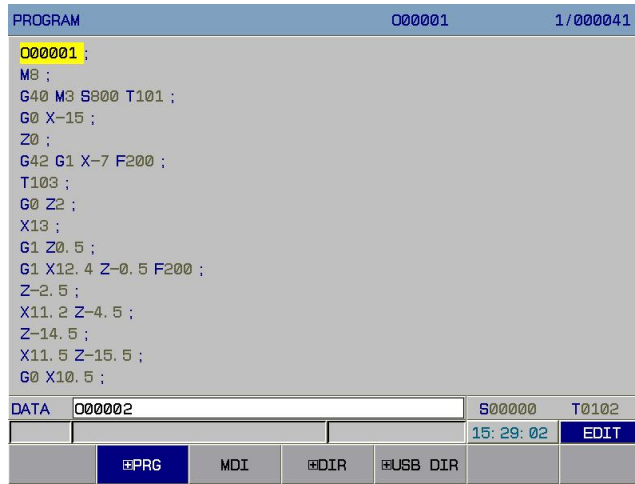



Fig.10-1-1-2-2

4. Press  to establish a new program name, as shown below (See Fig.10-1-1-2-3):

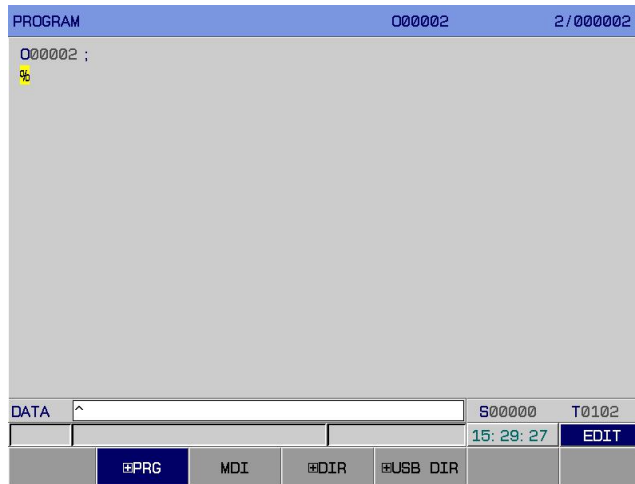



Fig.10-1-1-2-3

5. After a program is edited and inputted, the program is stored automatically when the system switches to another mode. Before switching to another interface (for example,  interface), it

is required to press  to store the inputted program.

Note 1: In editing mode, the system does not support inputting of a single number.

Note 2: If a code inputted is wrong during program input, it is allowed to press  to cancel the inputting of wrong code.

Note 3: At a time, the inputted block has maximum 65 characters.

10.1.1.3 Retrieving of sequence number, word, and line number



Sequence number retrieving is to retrieve some sequence number in the program, generally used for executing or editing the program from this number. Blocks that are skipped during retrieval do not influence CNC state. (The coordinate, **M**, **S**, **T** code, **G** code, etc. in a block skipped do not influence

the coordinate or mode of CNC.)

If execution starts from some block in retrieved program, it is required to figure out the current machine state and **CNC** state. The program cannot run unless it agrees with the setting of **M**, **S**, **T** code, and coordinate system.

Word retrieving is used for retrieving a certain address or number in the program, generally used in program editing.

Procedure of sequence number, word, line number retrieval in program:

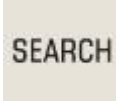





1. Select the mode: <edit> or <automatic>.
2. Search the target program in [catalog].
3. Press  to enter the target program.
4. Input the word or sequence number for retrieval. Press arrow key  or  to search it.
5. For line number searching, input the required line number, and press  for confirmation.







Note 1: Sequence number or word retrieving is canceled automatically when it comes to the end of program.

Note 2: In [automatic] and [edit] modes, it is allowed to conduct retrieval of sequence number, word, and line number. In [automatic] mode, however, retrieval can only be conducted on back-end editing interface.

10.1.1.4 Cursor positioning method

Select the editing mode. Press  to display the program page.

- a) Press  to move cursor upward one line. If the current column is greater than the ending column of last line, cursor moves to the tail of last line.
- b) Press  to move cursor downward one line. If the current column is greater than the ending column of next line, cursor moves to the tail of next line.
- c) Press  to move cursor right one column. Cursor can move to the head of next line if it is now at the tail of line.
- d) Press  to move cursor left one column. Cursor can move to the tail of last line if it is now at the head of line.
- e) Press  to scroll up, and cursor will move to last screen.
- f) Press  to scroll down, and cursor will move to next screen.
- g) Press , and cursor will move to the head of current line.

- h) Press  + , and cursor will return to the beginning of program.
- i) Press , and cursor will move to the tail of current line.
- j) Press  + , and cursor will return to the end of program.
- k) Double click on  for letter switching.

10.1.1.5 Insertion, deletion, and modification of words

Select <edit> mode and press  to display the program page. Locate cursor at the position for editing;

1. Insertion of words

Input a datum and press . Then, the system will insert this datum to the left side of cursor;

2. Deletion of words

Locate cursor at the position for deletion and press . The system will delete the content where cursor is.

3. Modification of words

Move cursor to the position to be modified. Input new content and press . The system will replace the content selected by cursor by new input.

10.1.1.6 Deletion of one block

Select <edit> mode and press  to enter the program page. Move cursor to the line head of

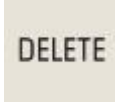
block to be deleted. Press  + , and the system will prompt "Please press <delete>

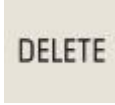
again". The user can delete the block where cursor is by pressing  on panel.

Note: A block, whether with a sequence number or not, can be deleted after the inputting of  (cursor should be at the head of line).

10.1.1.7 Modification of blocks

Delete the area from current word to the specified block.

N100 X100.0 M03 S2000; N2233 S02 ; N 2300 M30 ;

Current cursor position
To delete this area

Fig.10-1-1-7-1

Select <edit> mode and press  to enter the program page. Locate cursor at the home position of target to be deleted (for example, character N100 above). Then, input the last complete

character in multiple blocks to be deleted, **S02** for example (See Fig.10-1-1-7-1). Press 

and the system will prompt “Please press <delete> again”. Press  on panel to delete the program from cursor to marked address.

Note 1: The block deleted has maximum 10,000 lines.

Note 2: If many complete characters to be deleted are the same in the program, it is required to delete the program from first complete character to cursor character in the order of downward searching.

Note 3: When many blocks are deleted using N+ sequence number, the home position of N+ sequence number must be located at the head of that block.

10.1.1.8 Deletion of code words

Delete the program from current code word to specified code word.

N100 X100.0 M03 S2000; G01 X50.0 Y100.0 N2233 S02 ;

Current cursor position
To delete this area

Fig.10-1-1-8-1

Select <edit> mode and press  to enter the program page. Locate cursor at the home position of target to be deleted (for example, character N100 above). Then, input the last complete characters of multiple code words to be deleted, **Y100.0** for example (See Fig.10-1-1-8-1). Press

 .





The system will prompt “Please press <delete> again”. Press  on panel to delete the program from cursor to marked address.

Note: If N+ sequence number is located at the middle of block, the system will process it as a code word.



10.1.2 Deletion of one program

Delete some program from memory, as follows:

- a) Select <edit> mode;
- b) Enter the program page. There are two deletion methods:

1. Type the address ; input the program name (Type number keys , , ,

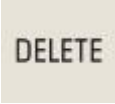
. Taking **O0002** program for example). Press  to delete the corresponding program in memory.

2. Select [catalog] interface on program interface. Select the program name to be deleted and press . The system presents: “Confirm deletion?” Then, press  and the state column presents “deletion success”. It means the program selected is deleted.

Note: If only one program file exists, after the deletion key is pressed on program (catalog) interface in editing mode, the program name will become O00001 and the program will be deleted no matter what it is. If many program files exist, the name and content of No.O00001 program are deleted together.

10.1.3 Deletion of all programs

Delete all programs from memory, as follows:

- a) Select <edit> mode;
- b) Enter the program page;

c) Type the address ;

d) Type address keys , , , , ,  successively.

e) Press  to delete all programs from memory.

10.1.4 Copying of program

The operation procedure is given below:

- a) Select <edit> mode.
- b) Enter the program page; select the program to be copied using cursor on [catalog] interface.

Press  to enter the program page;

- c) Press the address key  and input a new program number;
- d) Press [copy]. When copying finishes, enter a new program editing interface.
- e) Return to [catalog] to view the new program name.
- f) Copy current program and save it under another program name.



A program can also copied on program editing page (as shown in Fig.10-1-1):

- 1. Press the address key  and input a new program number;
- 2. Press [copy]. When copying finishes, enter a new program editing interface.
- 3. Return to [catalog] to view the new program name.

10.1.5 Copying and pasting of blocks

Procedure for block copy and paste:

- a) Move cursor to the head of block to be copied.
- b) Type the last character of block to be copied.

c) Press  followed by  or press [copy] directly, to finish copying the program from cursor to input character.

d) Move cursor to the position of pasting. Press  followed by  or press [Paste] directly, to finish pasting.

Note 1: If many complete characters to be copied are the same in the program, copy the program from the first complete character to cursor character in downward searching order.

Note 2: If program copying uses N+ sequence number mode, copy the program from cursor beginning to N+sequence number. The N+sequence number must be located at the head of block, or copying fails.

Note 3: The copied block can have maximum 10,000 lines.

10.1.6 Cutting and pasting of blocks

Procedure for block cut and paste:

- a) Enter the program editing page (as shown in Fig.10-1-1).
- b) Move cursor to the head of block to be cut.
- c) Type the last character of block to be cut.
- d) Press [Cut] to cut the program to the pasteboard.
- e) Move cursor to the position of pasting. Press [Paste] to finish pasting.

Note 1: If many complete characters to be cut are the same in the program, cut the program from the first complete character to cursor character in downward searching order.

Note 2: If program cutting uses N+ sequence number mode, cut the program from cursor beginning to N+sequence number.

Note 3: When a program name and its content are in the same block on program interface in editing mode, the system supports copying of characters behind program name but does not support their cutting.

10.1.7 Replacement of blocks

Procedure for block replacement:

- a) Enter the program editing page (as shown in Fig.10-1-1).
- b) Move cursor to the character to be replaced.
- c) Input the replacement content.
- d) Press [Replace]. The system replaces cursor positioning content and all the same content in the block by inputs.

Note: This operation is available for characters only not for a whole segment of block.

10.1.8 Renaming of program

Rename current program number another name.

- a) Select <edit> mode;
- b) Enter the program page (cursor specified program name);
- c) Type the address  and input a new program name;

ALTER

d) Press [ALTER] to finish file rename.

10.2 Program Management

10.2.1 Retrieval of program target

PROGRAM

Press [PROGRAM] and then press [catalog] on program interface to enter the program catalog page (See Fig.10-2-1-1):

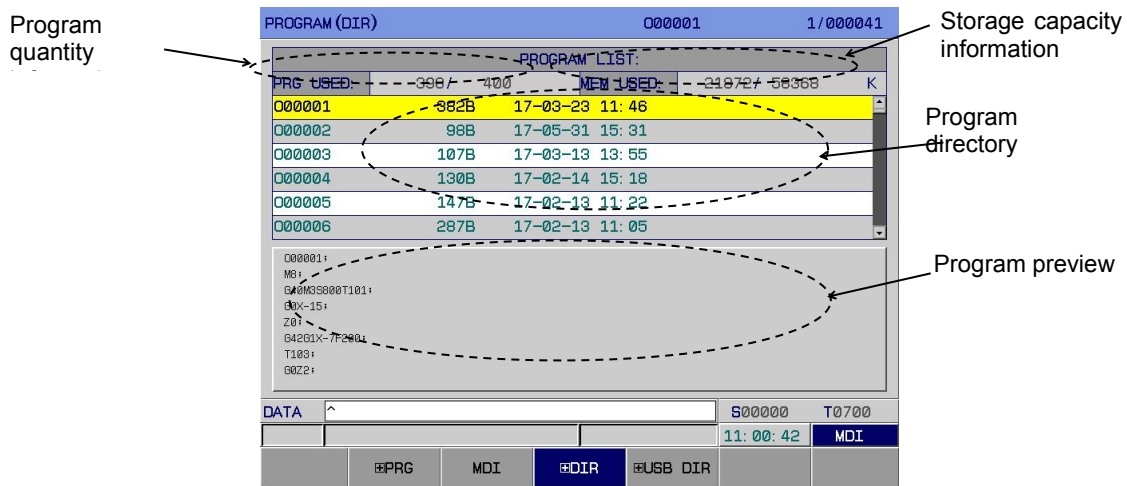

Fig.10-2-1-1

1) Program opening

Open a specified program: O+S/N+input (or EOB) or S/N+input (or EOB).

In editing mode, create a program if the sequence number inputted does not exist.

- 2) Program deletion: 1. In editing mode: Press DEL to delete the cursor specified program.
2. In editing mode: O+S/N+ DEL or S/N+ DEL.

10.2.2 Number of programs stored

This system can store maximum 400 programs. The current quantity stored is given in the program number information on program catalog page in 10.2.1.

10.2.3 storage capacity

For details fo storage capacity, please refer to the program catalog page in 10.2.1.

10.2.4 Viewing the program list

The program catalog page can display maximum 6 CNC program names at a time. If there are more than 6 CNC program names, they cannot be displayed on one page. In this case, the user can use PgUp PgDn. LCD will display **CNC** program names on next page. Repeat pressing PgUp PgDn, and LCD will display all these names in cycle.

10.2.5 Program locking

To prevent a user program from being modified or deleted without permission, this system sets a program switch. After program editing, turn off the program switch to lock the program. Then, the user cannot edit this locked program. See **3.3.1** for further information.

Chapter 11 System Communication

The system supports 2 kinds of communication interfaces, RS232 and USB, communicating with PC or U disk respectively for data transmission.

11.1 GSKComm Introduction

As a kind of communication management software specially provided for users, **GSKComm** communication software supports the serial port connection mode and can realize file uploading, editing, etc. between PC and CNC. It is easy to operate, with high communication efficiency and reliability. This software uses Windows interface, adapted to Win98, WinMe, WinXP, and Win2000.

Run **GSK980TB3iComm.exe** directly. After started, the program display the following interface:

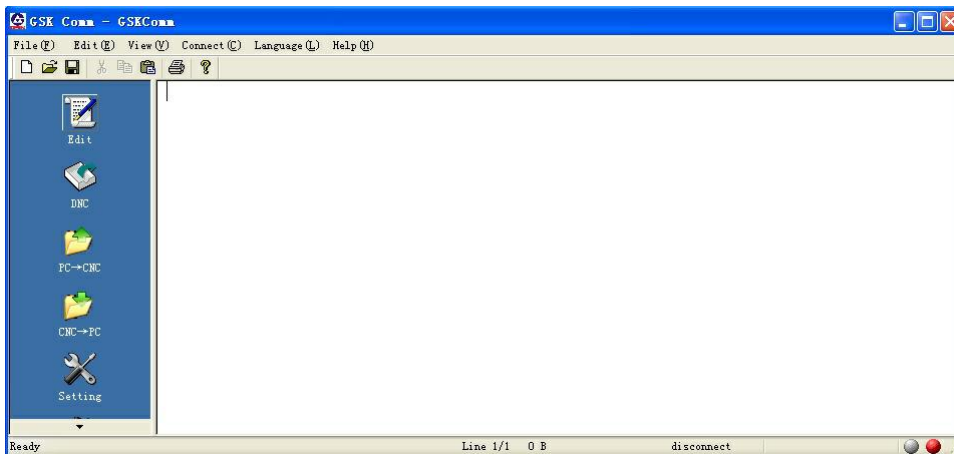



Fig.11-1-1

11.1.1 Function Introduction

1. File menu
This menu includes create, open, save, print, and print setting, list of files opened, etc.
2. Edit menu
This menu includes cancel, cut, copy, paste, select all, search, replace, etc.
3. View menu
This menu includes the display of tool bar and status bar.
4. Connect menu
This menu includes the connection and disconnection of serial port / ethernet port.
5. Main menu
This menu includes file editing, dnc transmission, pc—cnc transmission, _cnc—pc transmission, software and serial port setting, user management, statistics. Press the black triangle on main menu to view the menu content.
6. Help menu
Version information on this software.

Note: DNC transmission, user management, and statistics are not supported for the time being.

11.1.2 Editing operation

Click the main menu and press  to enter the file editing interface. The user can create a new part program file or open an existing part program file for editing.

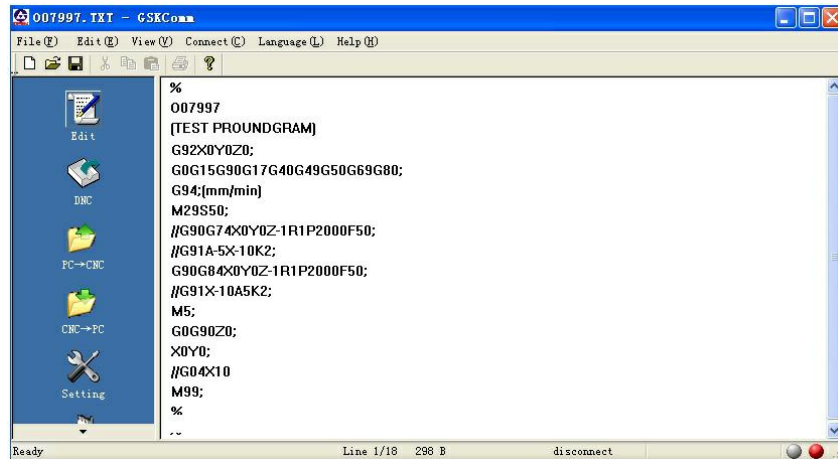



Fig.11-1-2-1

11.1.3 File sending (PC—CNC)

Click the main menu and press  to enter the file sending interface. Through the shortcut menu column at the right side of “send” interface, the user can either move cursor to the central file display bar and right click it before choosing corresponding operation in the popup of environment menu or select the file directly and press “send”. Through **[Add File]**, the user can add more files. He can choose one or more files to be added at a time. When the file to be added has an illegal name or when its size exceeds 4 M, that item will present red and its second column will present “×”. If both filename and file size are legal, the second column of this item will present “√” (as shown in Fig.11-1-3-1).

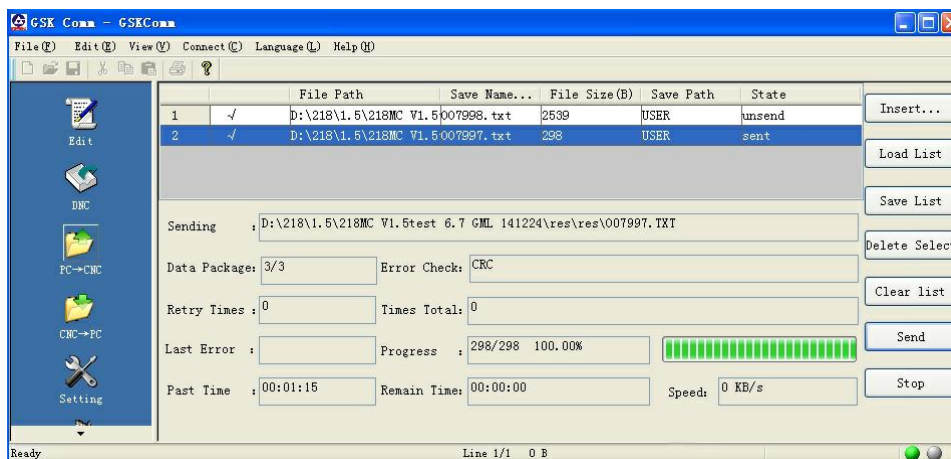

Fig.11-1-3-1

Press **[Load File List]** to add a file list saved; press **[Save List]** to save current file list; press **[Delete from List]** to delete one or more files at a time from the PC—CNC file list; press **[Clear List]** to clear the whole PC—CNC file list; press **[Send]** to send a selected file to CNC; press **[Stop]** to stop ongoing data transmission. The user can rank the file lists by clicking the head of sending list. After ranking, a small black triangle symbol will occur at the list head. The upward-pointing triangle

represents ascending and the downward-pointing triangle descending (as shown in Fig.11-1-3-2).

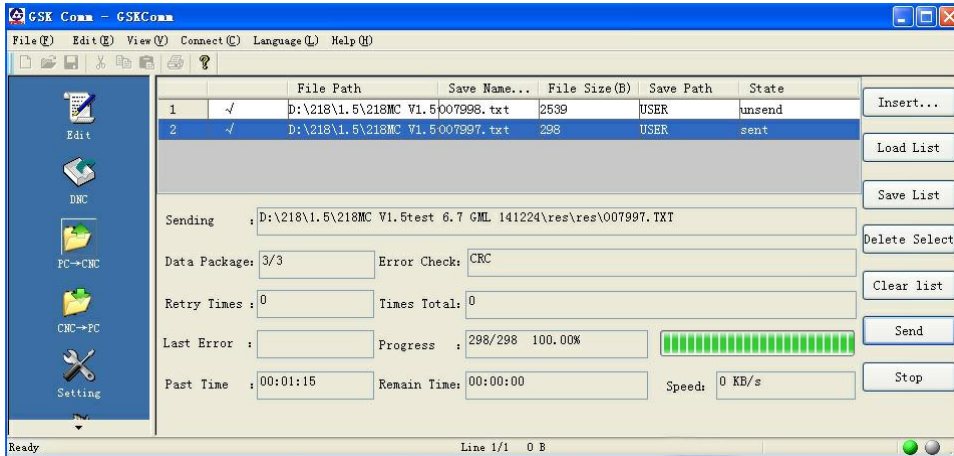

Fig.11-1-3-2

To transfer a file to CNC filename or memory area, the user can double click the list item to be modified and then make modification in the popup of dialog box shown in Fig.11-1-3-3.

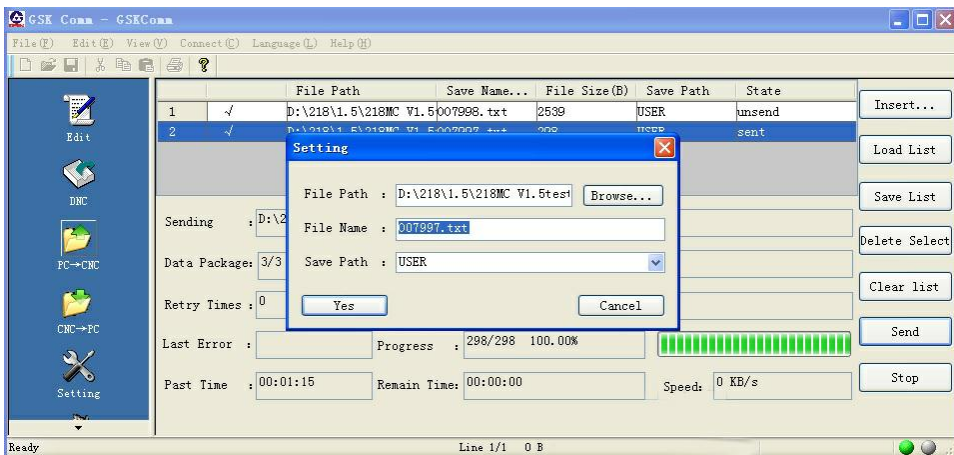

Fig.11-1-3-3

If the sent file has the same name with some file in CNC system, a dialog box, as is shown in Fig.11-1-3-4, will be popped up during sending. The user can press “Yes” to cover the original file, or press “No” to rename the sent file, or press “Cancel” to skip the sending of this file.

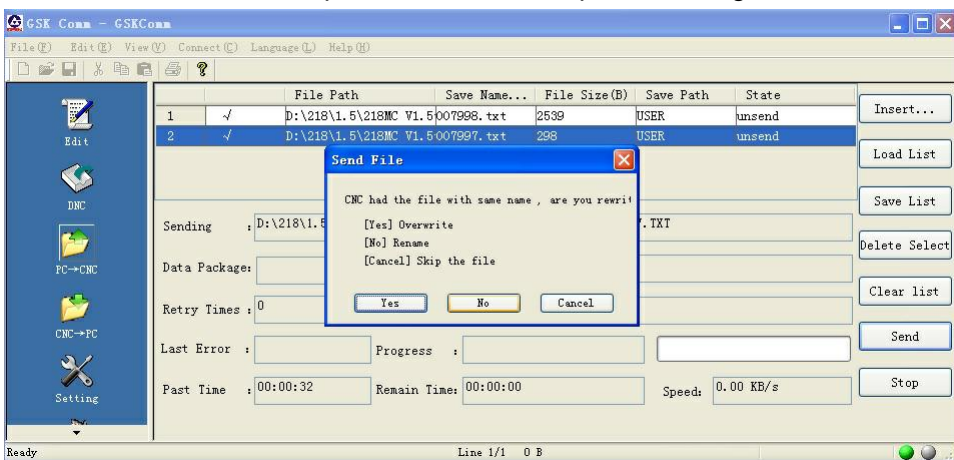

Fig.11-1-3-4

11.1.4 File receiving (CNC—PC)

Press [get CNC List] to get the file list at CNC system side; press [delete from list only] to delete

the chosen item from the file list; press **[delete CNC file]** to delete the chosen file from the file list and from CNC system; press **[receive]** and the display will pop up a dialog box (as shown in Fig.11-1-4-1) from which the user can choose where to put the received file; press **[Stop]** to stop file transmission.

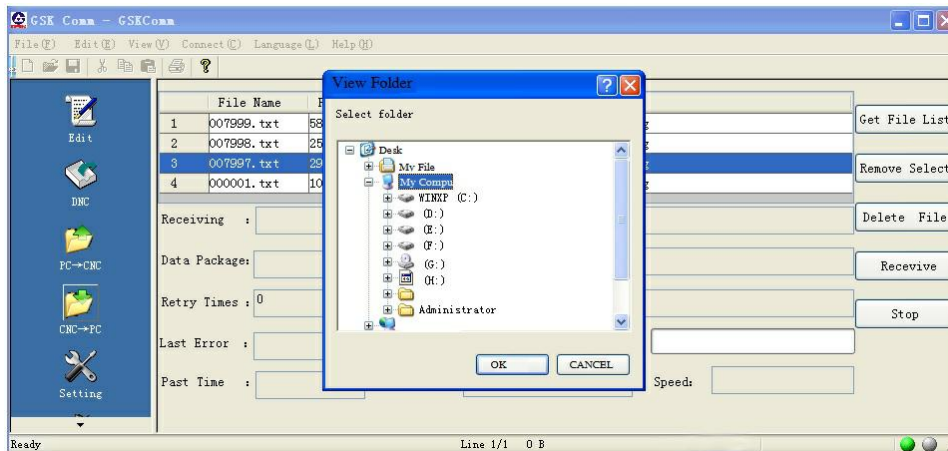

Fig.11-1-4-1

11.1.5 Software and serial port settings

The setting page is shown in Fig.11-1-5-1. Here, the user can set some parameters related to software and serial port.

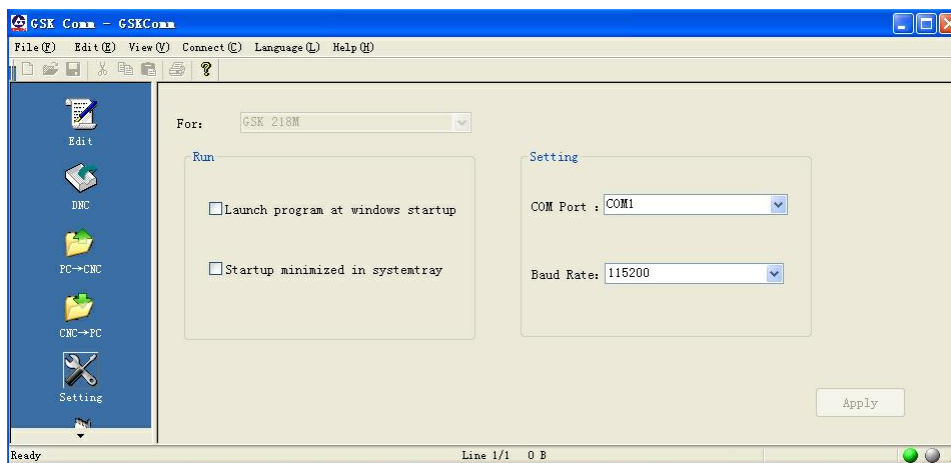

Fig.11-1-5-1

For program start setting, the user can set whether to run this software automatically when the system is powered on and whether to minimize the started software automatically at the lower right corner of screen; for communication setting, the user can choose a serial port and set its baud rate. (Press “apply” to implement the setting.)

Note: Automatic start of server during program running is not supported for the time being.

11.2 Serial Communication

11.2.1 Preparation for serial communication

1. Connect PC serial port (COM port) to system RS232 interface via serial port line.
2. Open PC-side GSK Comm communication software.
3. Setting of GSK Comm communication software:

(1). Setting of baud rate:

Click “setting” to enter the setting page so as to set the parameters related to serial communication;

Port selection: Choose a port for communication from the “serial port number” pull-down menu (Available PC ports are automatically recognized by the software);

Setting of baud rate: Make the baud rate of PC agrees with CNC through choices from “baud rate ” pull-down menu. Standard factory setting: The baud rate of data transmission is 115200.

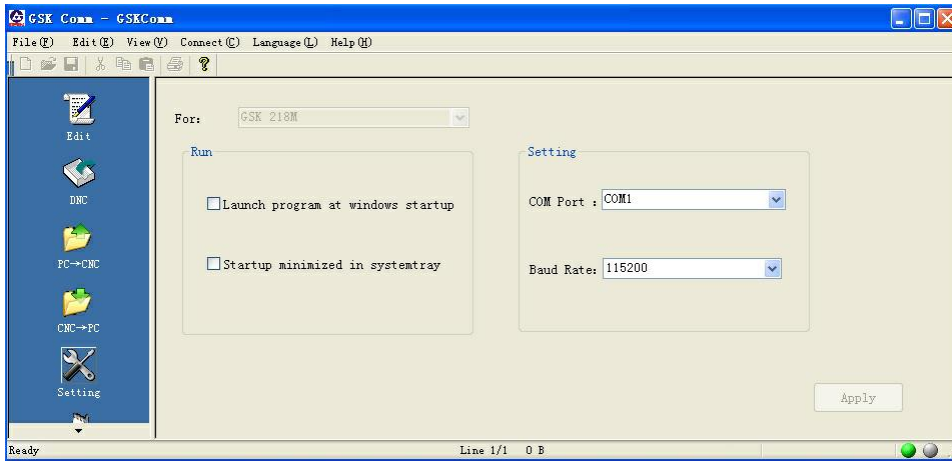

Fig.11-2-1-1

(2). Click “connect” menu, and then choose “pass serial port”. If the serial port opens successfully, the status bar will show “serial port opened” and the small icon at the lower right corner will be “green” and “gray”. However, this case only means the local serial port is opened. It does not represent that PC has connected to CNC system.

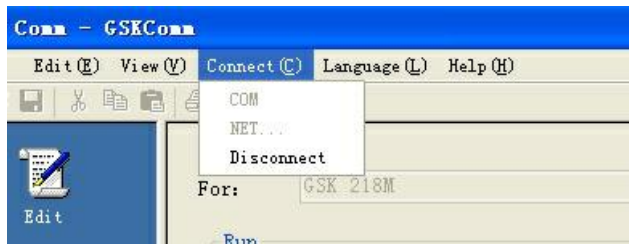

Fig.11-2-1-2

(3). Click “connect” menu, and then choose “disconnect” to disconnect the CNC system.

Note: Communication software can connect to the system via serial port only.

11.2.2 Serial data transmission

The operation procedure is given below:

1) Select <MDI> mode;



2) Press the button to enter the CNC setting page. Set I/O channel to 1.

3) The baud rate of data transmission is 115200.

4) Press [CNC setting] and input corresponding permission password. See 3.3.1.1 *Setting and Modification of Password Permissions* for details.

5) Press [data] to enter the setting (data processing) page. Move cursor to <CNC part program>

through  or .

A、 Data output (CNC→PC)

1. Press the system softkey [data output] and the system will prompt “waiting for transmission”.

2. Click  on GSK Comm communication software to enter the receive page.

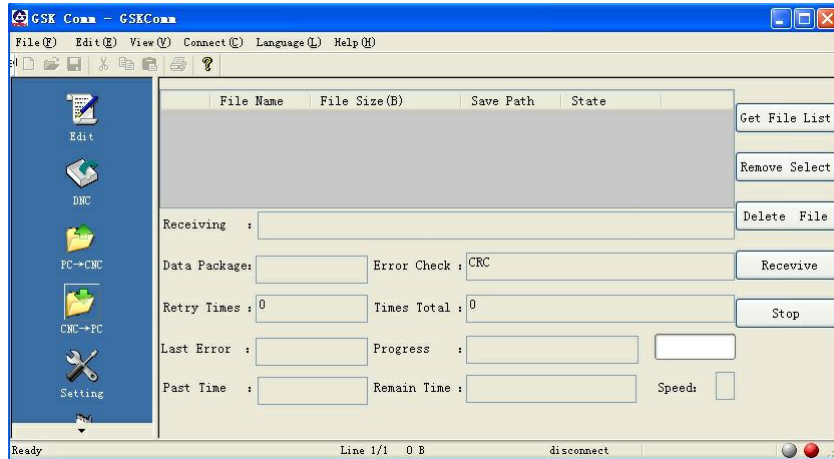



Fig.11-2-2-1

3. Click  to get the CNC-side file list, as shown in Fig.11-2-2-2.

	File Name	File Size(B)	Save Path	State
1	007999.txt	581364	user	Not receiving
2	007998.txt	2539	user	Not receiving
3	007997.txt	298	user	Received
4	000001.txt	10	user	Not receiving

Fig.11-2-2-2

4. Select files to be received (Several files can be received simultaneously) and then press . A dialog box is popped up for the user to choose the place of received files. Then, file receiving starts, as shown in Fig.11-2-2-3.

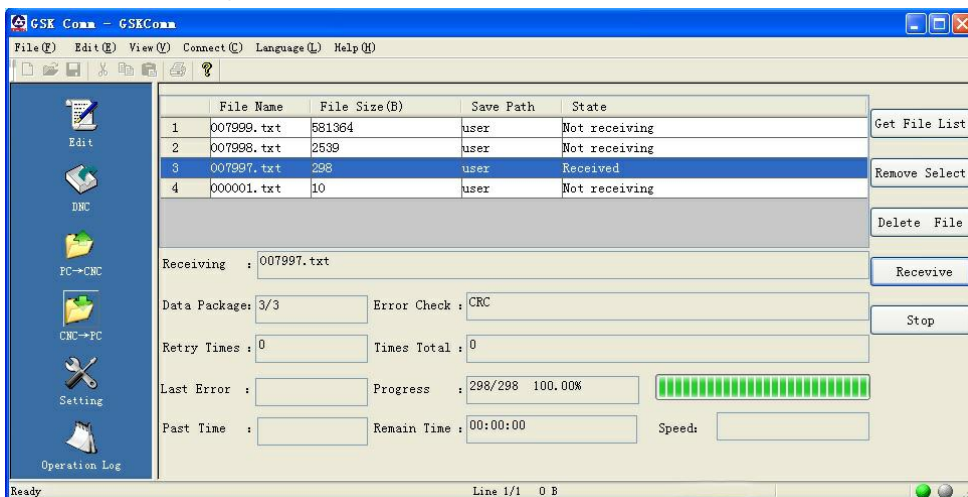

Fig.11-2-2-3

5. After a file received, its list item status bar presents “received”, as shown in Fig.11-2-2-4.

	File Name	File Size(B)	Save Path	State
1	007999.txt	581364	user	Not receiving
2	007998.txt	2539	user	Not receiving
3	007997.txt	298	user	Received
4	000001.txt	10	user	Not receiving

Fig.11-2-2-4

B、 Data input (PC→CNC)

1. Press the system softkey [data input] and the system will prompt “waiting for transmission”.



2. Click **PC→CNC** on GSK Comm communication software to enter the send page.

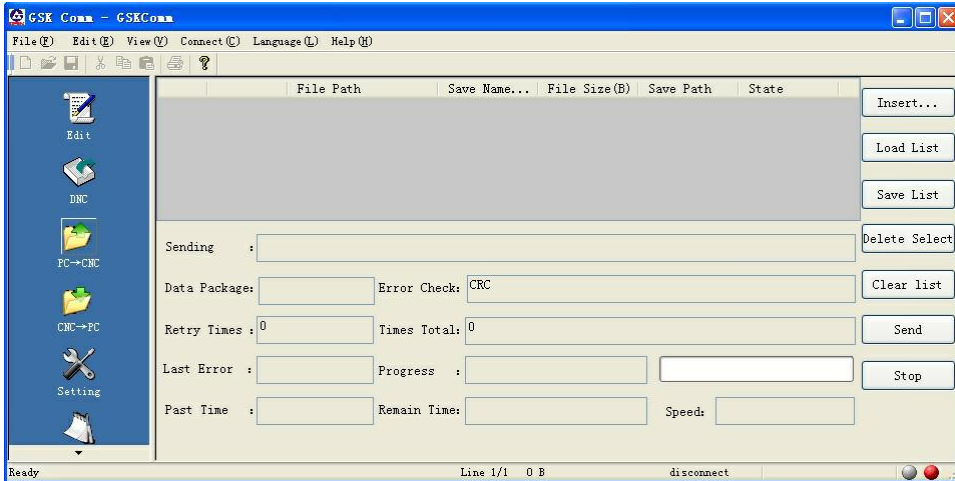

Fig.11-2-2-5

3. Click **Add File** to add the files to be sent to CNC, as shown in Fig.11-2-2-6.

		File Path	Save Name...	File ...	Save Path	State
1	✓	D:\218\1.5\218MC V1.5\081013.txt	72	USER	unsend	
2	✓	D:\218\1.5\218MC V1.5\081006.txt	159	USER	unsend	
3	✓	D:\218\1.5\218MC V1.5\007997.txt	298	USER	unsend	
4	✓	D:\218\1.5\218MC V1.5\081011.txt	634	USER	unsend	
5	✓	D:\218\1.5\218MC V1.5\081012.txt	959	USER	unsend	
6	✓	D:\218\1.5\218MC V1.5\081019.txt	968	USER	unsend	

Fig.11-2-2-6

4. Double click the send option to modify the file path, to save the file to CNC filename or memory area.

When sending CNC part program or user macro-program, the user should choose a user partition; when sending ladder graph (PLC), parameter (PLC), system parameter, tool compensation, pitch compensation, system macro-variable, etc., the user should choose a system partition.

5. After the partition is chosen, choose the file to be sent (It is allowed to send many files simultaneously), and then click **Send** to start sending, as shown in Fig.11-2-2-7.



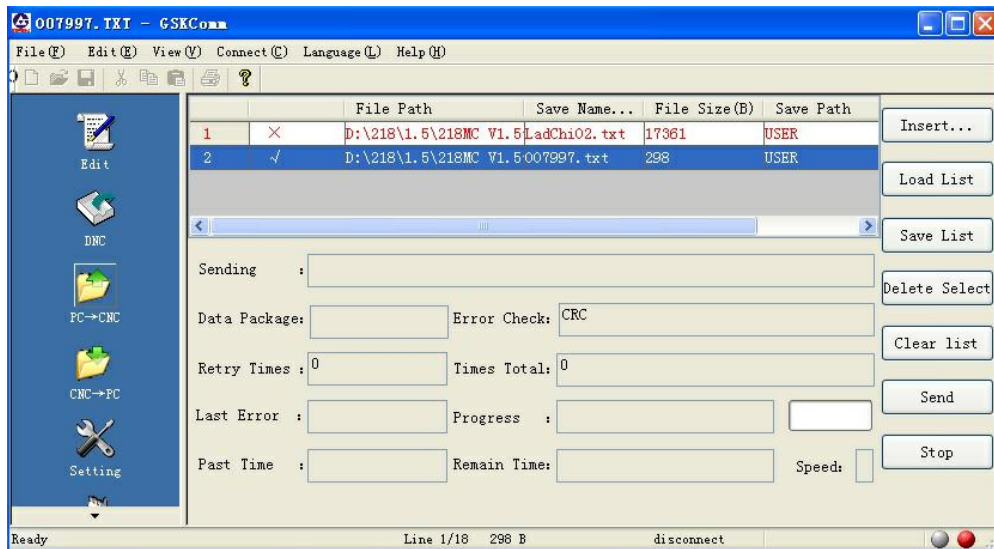

Fig.11-2-2-7

7、After sending, the dialogue status bar shows “sent”, as shown in Fig.11-2-2-8

		File Path	Save Name...	File Size(B)	Save Path	State
1	✓	D:\218\1.5\218MC V1.5\007998.txt	007998.txt	2539	USER	unsent
2	✓	D:\218\1.5\218MC V1.5\007997.txt	007997.txt	298	USER	sent

Fig.11-2-2-8

Note 1: For descriptions of other function on send page, please refer to 11.1.4 PC—CNC File Sending; for descriptions of other function on receive page, please refer to 11.1.4 CNC—PC File Receiving.

Note 2: Please ensure that the baud rate is set properly and that the serial port line is connected reliably, before data transmission.

Note 3: During data transmission, it is forbidden to switch the system operation mode or system page, in order to avoid data transmission errors.

Note 4: After transmitted to the system, LADCHI**.TXT file is invalid without restart.

11.3 USB Communication



11.3.1 Overview and attentions

Attentions:

1. Set I/O channel to 2 on <CNC setting> interface.
2. A CNC program file must have a suffix .txt, .nc or .CNC, and be saved in the root directory of U disk, or the system cannot read it.
3. It is forbidden to pull out U disk during USB transmission communication, in order to avoid product defaults or unexpected consequences.
4. After U disk communication ends, it is required not to pull out U disk before the U disk indicator light stops flickering (or before a while), in order to ensure data transmission is finished.

11.3.2 Operation procedures of USB Part Program

In <MDI mode>, enter the system [data] interface, and then move cursor to “CNC part program ”

through  or . Press [data output] or [data input] to enter the following operation

interface (Fig.11-3-2-1):

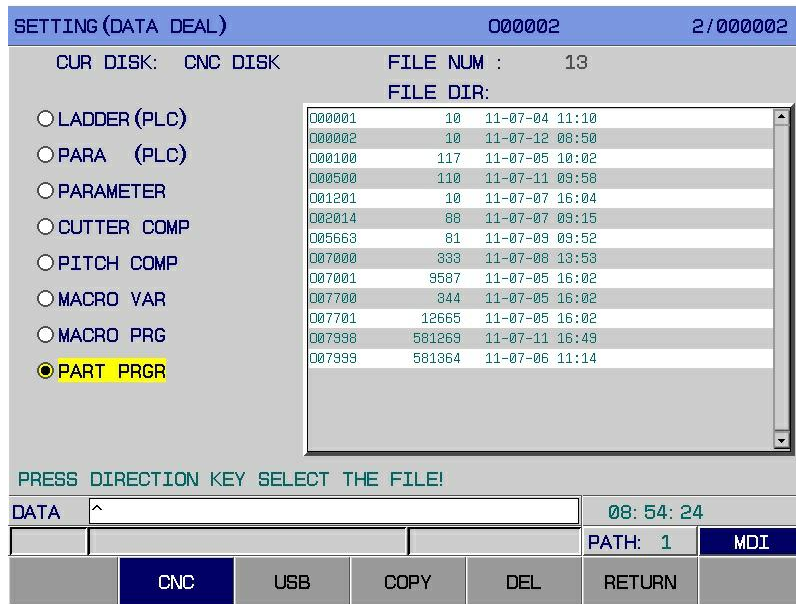





Fig.11-3-2-1

1. Copy a CNC program file from system disk to U disk:

- a. Press the arrow key  to switch cursor to the file directory table.
- b. Move cursor through  or  to select the CNC program file to be copied from system disk.
- c. Press [copy]. The system presents a prompt “Copy it to U disk? New file name”, as shown below (Fig.11-3-2-2).

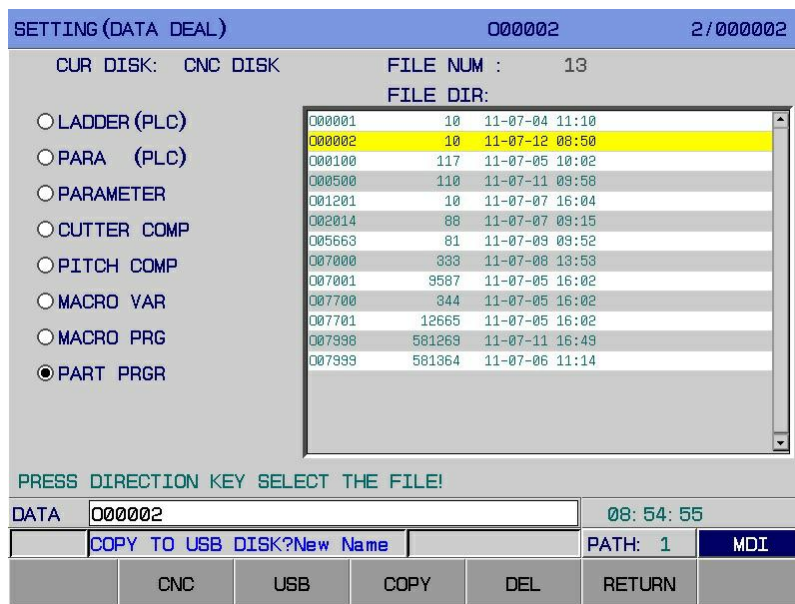

Fig.11-3-2-2



- d. If renaming is not required, press <MDI> to copy the CNC program file directly; if renaming is necessary, press <cancel> before typing a new program number (such as O10 or O100) and then

press <MDI> to copy the CNC program file. If a file existing in U disk has the same name as this file, the system will present a prompt “Copy to U disk? Please rename”. In this case, type a new program number (such as O10 or O100) and press <MDI> again to copy the CNC program file.

2. Copy a CNC program file from U disk to system disk:

a. Press [U disk] to switch to the file directory table display interface in U disk.

b. Press the arrow key  to switch cursor to the file directory table.

c. Move cursor through  or  to select the CNC program file to be copied from U disk.

Press [copy]. The system presents a prompt “Copy it to U disk? New file name”, as shown below (Fig.11-3-2-3).

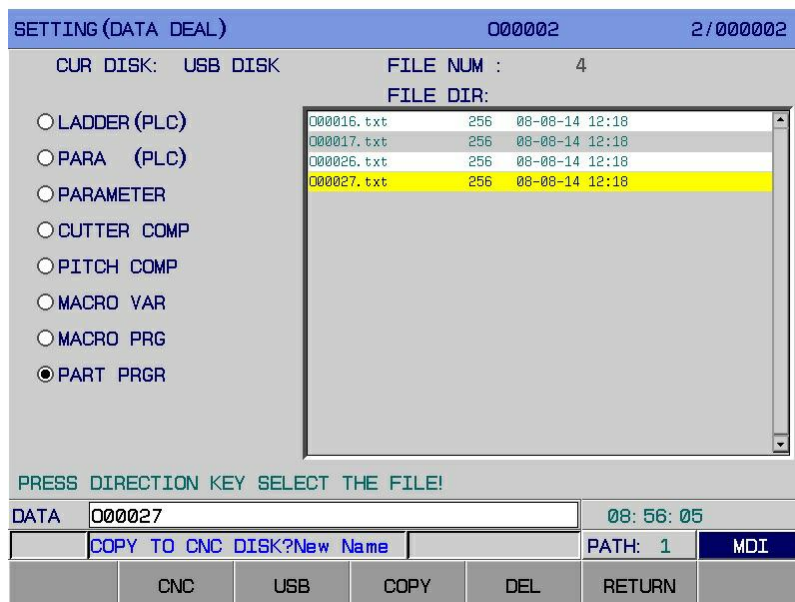



Fig.11-3-2-3

d. If renaming is not required, press <MDI> to copy the CNC program file directly; if renaming is necessary, press <cancel> before typing a new program number (such as O10 or O100) and then press <MDI> to copy the CNC program file. If a file existing in system disk has the same name as this file, the system will present a prompt “Copy to system disk? Please rename”. In this case, type a new program number (such as O10 or O100) and press <MDI> again to copy the CNC program file.

Note: After transmitted to the system, LADCHI**.TXT file is invalid without restart.

3. Delete a file from system disk/U disk:

a. Move cursor through  or  to select the CNC program file to be deleted from system disk / U disk.

b. Press [delete] and the interface bottom prompts: “Confirm deletion?” Press <cancel> to cancel deletion; press <MDI> to delete the file.

11.3.3 Exiting from U disk operation interface

1. Pull U disk out when U disk indicator does not flicker.
Press [back] to return to [system (data processing)] interface.

Appendixes

Appendix I List of GSK980TB3i Series Parameters

Parameter description

By data type, parameters can be divided into the following categories:
2 kinds of data types and effective ranges of data value

Data Type	Effective Range	Note Remarks
Bit	0 or 1	System default, which the user can modify as required.
Number	Depend on parameter range	System default range and default value, which the user can modify as required.

1. For bit parameters, each datum consists of 8 bits. Each bit has its unique meaning.
2. For data types above, their value ranges are generally effective. Specific parameter value ranges are not the same. Please refer to the specification of parameters.

[Example]

(1) Meaning of bit parameters

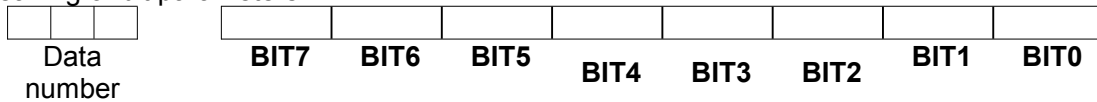

(2) Meaning of number parameters

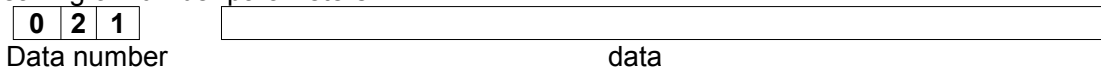

Note 1: The space bits in parameter description and the Parameter No.s displayed but not recorded in parameter list should be set to 0 because they are reserved for future extension.

Note 2: Where 0, 1 in parameters do not have specified meanings, it is understood that 1 is positive and 0 negative.

Note 3: When INI is set to 0, for metric input, the parameter setting unit of linear axis is mm or mm/min; the base unit of rotating axis is deg or deg/min.

When INI is set to 1, for British input, the parameter setting unit of linear axis is inch or inch/min; the base unit of rotating axis is deg or deg/min.

1. Position Parameters

Sys Para No.

0	0	0		SVCD	SEQ	MSP		INI	INM	PBUS
---	---	---	--	------	-----	-----	--	-----	-----	------

PBUS =1: transmission mode of drive unit: bus
 =0: transmission mode of drive unit: pulse

INM =1: The least command increment of linear axis is British.
 =0: The least command increment of linear axis is metric.

For metric output with **INM** set to 0: the base unit of linear axis is mm or mm/min; the base unit of rotating axis is deg or deg/min.

For British output with **INM** set to 1: the base unit of linear axis is inch or inch/min; the base unit of rotating axis is deg or deg/min.

INI =1: British input.
 =0: Metric input.

For metric input with **INI** set to 0: the base unit of linear axis is mm or mm/min; the base unit of rotating axis is deg or deg/min.

For British input with **INI** set to 1: the base unit of linear axis is inch or inch/min; the base unit of rotating axis is deg or deg/min.

MSP =1: Adopt twin-spindle control.
 =0: Do not adopt twin-spindle control.

SEQ =1: Insert sequence numbers automatically.
 =0: Do not insert sequence numbers automatically.

SVCD =1: Use bus servo card.
 =0: Do not use bus servo card.

Standard setting: 0 0 0 0 0 0 0 1

Sys Para No.

0	0	1		SPM2	SPPT	SPEP	SPOM	SPT	SBUS	RASA
---	---	---	--	------	------	------	------	-----	------	------

RASA =1: Use absolute grating.
 =0: Do not use absolute grating.

SBUS =1: The drive unit of spindle adopts bus control.
 =0: The drive unit of spindle adopts non-bus control.

SPT =1: I/O point control.
 =0: Variable-frequency or others.

SPOM =1: Select pulse string frequency for spindle speed control signal output.
 =0: Select analog voltage for spindle speed control signal output.

SPEP =1: Encoder feedback interface of bus spindle: XS32 encoder interface
 =0: Encoder feedback interface of bus spindle: the same as output interface

SPPT =1: Spindle pulse output mode: AB phase output
 =0: Spindle pulse output mode: pulse + direction

SPM2 =1: Speed output of the 2nd spindle: pulse string position
 =0: Speed output of the 2nd spindle: analog voltage

Standard setting: 0 0 1 0 1 0 0 0

Sys Para No.

0	0	2				DEC5	DEC4	DEC3	DEC2	DEC1
---	---	---	--	--	--	------	------	------	------	------

- DEC1** =1: When returning to the reference point, the 1st axis slows down if DECX is 1.
=0: When returning to the reference point, the 1st axis slows down if DECX is 0.
- DEC2** =1: When returning to the reference point, the 2nd axis slows down if DECX is 1.
=0: When returning to the reference point, the 2nd axis slows down if DECX is 0.
- DEC3** =1: When returning to the reference point, the 3rd axis slows down if DECX is 1.
=0: When returning to the reference point, the 3rd axis slows down if DECX is 0.
- DEC4** =1: When returning to the reference point, the 4th axis slows down if DECX is 1.
=0: When returning to the reference point, the 4th axis slows down if DECX is 0.
- DEC5** =1: When returning to the reference point, the 5th axis slows down if DECX is 1.
=0: When returning to the reference point, the 5th axis slows down if DECX is 0.

Standard setting: 0 0 0 0 0 0 0 0

Sys Para No.

0	0	3				DIR5	DIR4	DIR3	DIR2	DIR1
---	---	---	--	--	--	------	------	------	------	------

- DIR1** =1: The feeding direction of the 1st axis is reversed.
=0: The feeding direction of the 1st axis is not reversed.
- DIR2** =1: The feeding direction of the 2nd axis is reversed.
=0: The feeding direction of the 2nd axis is not reversed.
- DIR3** =1: The feeding direction of the 3rd axis is reversed.
=0: The feeding direction of the 3rd axis is not reversed.
- DIR4** =1: The feeding direction of the 4th axis is reversed.
=0: The feeding direction of the 4th axis is not reversed.
- DIR5** =1: The feeding direction of the 5th axis is reversed.
=0: The feeding direction of the 5th axis is not reversed.

Standard setting: 0 0 0 0 0 0 0 0

Sys Para No.

0	0	4	SK0							
---	---	---	-----	--	--	--	--	--	--	--

- SK0** =1: The jump signal SIKP is inputted as the signal, if it is 0.
=0: The jump signal SIKP is inputted as the signal, if it is 1.

Standard setting: 0 0 0 0 0 0 0 0

Sys Para No.

0	0	5	DOUS					ISC	
---	---	---	------	--	--	--	--	-----	--

- ISC** =1: The least command increment is 0.0001 mm° or 0.00001 inch.
=0: The least command increment is 0.001 mm° or 0.0001 inch.
- DOUS** =1: The double-drive tool uses raster position.
=0: The double-drive tool does not use raster position.

Standard setting: 0 0 0 0 0 0 1 0

Sys Para No.

0	0	6	MAOB	ZPLS	SIOD	SJZ	AZR	JAX	ZMOD	ZRN
---	---	---	------	------	------	-----	-----	-----	------	-----

- ZRN** =1: The reference point has not been established, and the system gives an alarm if a code other than G28 is specified in automatic running.
 =0: The reference point has not been established, and the system does not give an alarm if a code other than G28 is specified in automatic running.
- ZMOD** =1: Zeroing mode: in front of baffle block.
 =0: Zeroing mode: behind baffle block.
- JAX** =1: Control axis during manual returning to the reference point: single axis.
 =0: Control axis during manual returning to the reference point: multi-shaft
- AZR** =1: G28 command before the reference point is established: alarm
 =0: G28 command before the reference point is established: baffle block
- SJZ** =1: Reference point memorizing
 =0: Reference point not memorizing
- SIOD** =1: Mechanical zeroing DECX: through PLC logical operations.
 =0: Mechanical zeroing DECX: read X signal directly.
- ZPLS** =1: Reset mode: with one turn of signal.
 =0: Reset mode: without one turn of signal.
- MAOB** =1: Reset mode without one turn of signal: B mode.
 =0: Reset mode without one turn of signal: A mode.

Standard setting: 1 1 1 0 0 0 0 1

Sys Para No.

0	0	7				ZMI5	ZMI4	ZMI3	ZMI2	ZMI1
---	---	---	--	--	--	------	------	------	------	------

- ZMI1** =1: Set the direction from the 1st axis to the reference point: negative.
 =0: Set the direction from the 1st axis to the reference point: positive.
- ZMI2** =1: Set the direction from the 2nd axis to the reference point: negative.
 =0: Set the direction from the 2nd axis to the reference point: positive.
- ZMI3** =1: Set the direction from the 3rd axis to the reference point: negative.
 =0: Set the direction from the 3rd axis to the reference point: positive.
- ZMI4** =1: Set the direction from the 4th axis to the reference point: negative.
 =0: Set the direction from the 4th axis to the reference point: positive.
- ZMI5** =1: Set the direction from the 5th axis to the reference point: negative.
 =0: Set the direction from the 5th axis to the reference point: positive.

Standard setting: 0 0 0 0 0 0 0 0

Sys Para No.

0	0	8				ROT5	ROT4	ROT3	ROT2	ROT1
---	---	---	--	--	--	------	------	------	------	------

- ROT1** =1: The 1st axis is set as rotating axis.
=0: The 1st axis is set as linear axis.
- ROT2** =1: The 2nd axis is set as rotating axis.
=0: The 2nd axis is set as linear axis.
- ROT3** =1: The 3rd axis is set as rotating axis.
=0: The 3rd axis is set as linear axis.
- ROT4** =1: The 4th axis is set as rotating axis.
=0: The 4th axis is set as linear axis.
- ROT5** =1: The 5th axis is set as rotating axis.
=0: The 5th axis is set as linear axis.

Standard setting: 0 0 0 1 1 0 0 0

Sys Para No.

0	0	9	DTO	RAB		ROS5	ROS4	ROS3	ROS2	ROS1
---	---	---	-----	-----	--	------	------	------	------	------

- ROS1** =1: The rotating axis type of the 1st axis: B type, with a coordinate of linear axis type.
=0: The rotating axis type of the 1st axis: A type, with a coordinate within 3~360.
- ROS2** =1: The rotating axis type of the 2nd axis: B type, with a coordinate of linear axis type.
=0: The rotating axis type of the 2nd axis: A type, with a coordinate within 3~360.
- ROS3** =1: The rotating axis type of the 3rd axis: B type, with a coordinate of linear axis type.
=0: The rotating axis type of the 3rd axis: A type, with a coordinate within 3~360.
- ROS4** =1: The rotating axis type of the 4th axis: B type, with a coordinate of linear axis type.
=0: The rotating axis type of the 4th axis: A type, with a coordinate within 3~360.
- ROS5** =1: The rotating axis type of the 5th axis: B type, with a coordinate of linear axis type.
=0: The rotating axis type of the 5th axis: A type, with a coordinate within 3~360.
- RAB** =1: Each axis rotates nearby when acting as the rotating axis.
=0: No one axis rotates nearby when acting as the rotating axis.
- DTO** =1: Input type of rotating axis in cylindrical interpolation: expand the planar distance.
=0: Input type of rotating axis in cylindrical interpolation: angle.

Standard setting: 0 1 0 0 0 0 0 0

Sys Para No.

0	1	0	RCUR	MSL	WCZS		RLC	ZCL	SCBM	
---	---	---	------	-----	------	--	-----	-----	------	--

- SCBM** =1: Do stroke testing before the move.
 =0: Do not do stroke testing before the move.
- ZCL** =1: Clear the relative coordinate returning to the reference point.
 =0: Do not clear the relative coordinate returning to the reference point.
- RLC** =1: Cancel the relative coordinate system after reset.
 =0: Do not cancel the relative coordinate system after reset.
- WCZS** =1: zero-point input value of workpiece coordinate system minus that of machine coordinate system
 =0: zero-point input value of workpiece coordinate system plus that of machine coordinate system
- MSL** =1: When multiple MDI blocks are started in cycle, the start line is where cursor is.
 =0: When multiple MDI blocks are started in cycle, the start line is top line of the program.
- RCUR** =1: For reset in non-editing mode, cursor returns to the home position.
 =0: For reset in non-editing mode, cursor does not return to the home position.

Standard setting: 0 0 1 0 0 1 1 0

Sys Para No.

0	1	1	BFA	LZR						OUT2
---	---	---	-----	-----	--	--	--	--	--	------

- OUT2** =1: No entry to the outside area of second stroke limit.
 =0: No entry to the inside area of second stroke limit.
- LZR** =1: Do stroke testing after power-on before manual returning to the reference point.
 =0: Do not do stroke testing after power-on before manual returning to the reference point.
- BFA** =1: If an over-travel code is sent, the alarm is given after over-travel.
 =0: If an over-travel code is sent, the alarm is given before over-travel. (The scope of system alarm is 5MM in front of each boundary of keepout areas.)

Standard setting: 0 0 0 0 0 0 0 1

Sys Para No.

0	1	2	RDR	FDR	TDR	RFO			LRP	RPD
---	---	---	-----	-----	-----	-----	--	--	-----	-----

- RPD** =1: From power-on to returning to the reference point, manual fast is valid.
=0: From power-on to returning to the reference point, manual fast is invalid.
- LRP** =1: Determine (G00) interpolation type to be linear.
=0: Determine (G00) interpolation type to be non-linear.
- RFO** =1: Rapid feed, which stops when feed magnification is Fo.
=0: Rapid feed, which does not stop when feed magnification is Fo.
- TDR** =1: Dry running is valid during tapping.
=0: Dry running is invalid during tapping.
- FDR** =1: Dry running is valid during cutting feed.
=0: Dry running is invalid during cutting feed.
- RDR** =1: Dry running is valid during rapid positioning.
=0: Dry running is invalid during rapid positioning.

Standard setting: 0 0 0 0 0 0 1 0

Sys Para No.

0	1	3					HPC2		HPC	NPC
---	---	---	--	--	--	--	------	--	-----	-----

- NPC** =1: The feed per revolution is valid after the position encoder is installed.
=0: The feed per revolution is invalid before the position encoder is installed.
- HPC** =1: The system has a position encoder installed.
=0: The system does not have a position encoder installed.
- HPC2** =1: The 2nd spindle has a position encoder installed.
=0: The 2nd spindle does not have a position encoder installed.

Standard setting: 0 0 0 0 0 0 1 0

Sys Para No.

0	1	4	ROVT						DLF	
---	---	---	------	--	--	--	--	--	-----	--

- DLF** =1: After the reference point is established and memorized, manual zeroing is located at the reference point at manual fast speed.
=0: After the reference point is established and memorized, manual zeroing is located at the reference point at rapid positioning speed.
- ROVT** =1: Rapid magnification adopts 6 gears.
=0: Rapid magnification adopts 4 gears.

Standard setting: 0 0 0 0 0 0 0 0

Sys Para No.

0	1	5	PCKM	RPCK	PIIS		PPCK	ASL	PLAC	STL
---	---	---	------	------	------	--	------	-----	------	-----

- STL** =1: Select the read-ahead processing mode.
=0: Select the no-read-ahead processing mode.
- PLAC** =1: Mode of after-interpolating speed controlling in predictive control: exponential.
=0: Mode of after-interpolating speed controlling in predictive control: linear.
- ASL** =1: Automatic corner deceleration function in predictive control: speed difference control
=0: Automatic corner deceleration function in predictive control: angular difference control
- PPCK** =1: Predictive control includes in-position testing.
=0: Predictive control excludes in-position testing.
- PIIS** =1: Overlapping interpolation of before-interpolating speed controlling block in predictive control is valid.
=0: Overlapping interpolation of before-interpolating speed controlling block in predictive control is invalid.
- RPCK** =1: For rapid positioning, in-position testing is valid.
=0: For rapid positioning, in-position testing is invalid.
- PCKM** =1: Rapid positioning uses the motor in-position sign.
=0: Rapid positioning does not use the motor in-position sign.

Standard setting: 0 0 0 0 0 0 0 1

Sys Para No.

0	1	6	ALS		JOG			CUTT		PRT
---	---	---	-----	--	-----	--	--	------	--	-----

- PRT** =1: Speed controlling type in rapid running: constant acceleration.
=0: Speed controlling type in rapid running: constant time constant.
- CRTT** =1: Cutting pattern: B.
=0: Cutting pattern: A.
- JOG** =1: The manual continuous feed speed of each axis is valid.
=0: The manual continuous feed speed of each axis is invalid.
- ALS** =1: The automatic corner feed function is valid.
=0: The automatic corner feed function is invalid.

Standard setting: 0 0 0 0 0 0 1 0

Sys Para No.

0	1	7	CPCT	CALT	WLOE			CLLE	CBLS	CBOL
---	---	---	------	------	------	--	--	------	------	------

- CBOL** =1: Cutting feed mode: speed controlling after.
=0: Cutting feed mode: speed controlling before.
- CBLS** =1: Speed controlling before cutting feed: S-type.
=0: Speed controlling before cutting feed: linear.
- CLLE** =1: Speed controlling after cutting feed: exponential.
=0: Speed controlling after cutting feed: linear.
- WLOE** =1: Manual pulse running: exponential.
=0: Manual pulse running: linear.
- CALT** =1: Cutting feed controls acceleration.
=0: Cutting feed does not control acceleration.
- CPCT** =1: Cutting feed controls the positioning accuracy.
=0: Cutting feed does not control the positioning accuracy.

Standard setting: 1 0 1 0 0 0 0 1

Sys Para No.

0	1	8	RVCS	RBK						RVIT
---	---	---	------	-----	--	--	--	--	--	------

- RVIT** =1: If the backlash is greater than the clearance tolerance, interpolation is finished before execution of next block.
=0: If the backlash is greater than the clearance tolerance, interpolation is unfinished before execution of next block.
- RBK** =1: Do backlash compensation for cutting and fast motion respectively.
=0: Do not do backlash compensation for cutting and fast motion respectively.
If P18.6 is 0: P190~194 (backlash compensation amount for the 1st axis ~the 5th axis).
If P18.6 is 1: G00:P231~P235 (backlash compensation amount during fast motion of the 1st axis ~the 5th axis).
G01: P190~194 (backlash compensation amounts on the 1st axis ~ the 5th axis).
- RVCS** =1: Backlash compensation mode: speed controlling.
=0: Backlash compensation mode: fixed frequency.

Standard setting: 0 0 0 0 0 0 0 0

Sys Para No.

0	1	9		ALS2	ALS1	ALM5	ALM4	ALM3	ALM2	ALM1
---	---	---	--	------	------	------	------	------	------	------

- ALM1** =1: Give an alarm when the alarm signal of the 1st axis drive unit is 1.
=0: Give an alarm when the alarm signal of the 1st axis drive unit is 0.
- ALM2** =1: Give an alarm when the alarm signal of the 2nd axis drive unit is 1.
=0: Give an alarm when the alarm signal of the 2nd axis drive unit is 0.
- ALM3** =1: Give an alarm when the alarm signal of the 3rd axis drive unit is 1.
=0: Give an alarm when the alarm signal of the 3rd axis drive unit is 0.
- ALM4** =1: Give an alarm when the alarm signal of the 4th axis drive unit is 1.
=0: Give an alarm when the alarm signal of the 4th axis drive unit is 0.
- ALM5** =1: Give an alarm when the alarm signal of the 5th axis drive unit is 1.
=0: Give an alarm when the alarm signal of the 5th axis drive unit is 0.
- ALS1** =1: Give an alarm when the alarm signal of the 1st spindle drive unit is 1.
=0: Give an alarm when the alarm signal of the 1st spindle drive unit is 0.
- ALS2** =1: Give an alarm when the alarm signal of the 2nd spindle drive unit is 1.
=0: Give an alarm when the alarm signal of the 2nd spindle drive unit is 0.

Standard setting: 0 0 1 0 0 0 0 0

Sys Para No.

0	2	0					DIT	ITX	ITL
---	---	---	--	--	--	--	-----	-----	-----

- ITL** =1: The interlocking signal on each axis is valid.
=0: The interlocking signal on each axis is invalid.
- ITX** =1: The mutual sales signal on each axis is valid.
=0: The mutual sales signal on each axis is invalid.
- DIT** =1: The mutual sales signal in each axial direction is valid.
=0: The mutual sales signal in each axial direction is invalid.

Standard setting: 0 0 0 0 0 0 0 0

Sys Para No.

0	2	1				APC5	APC4	APC3	APC2	APC1
---	---	---	--	--	--	------	------	------	------	------

- APC1** =1: Type of servo encoder on the 1st axis: absolute.
=0: Type of servo encoder on the 1st axis: incremental.
- APC2** =1: Type of servo encoder on the 2nd axis: absolute.
=0: Type of servo encoder on the 2nd axis: incremental.
- APC3** =1: Type of servo encoder on the 3rd axis: absolute.
=0: Type of servo encoder on the 3rd axis: incremental.
- APC4** =1: Type of servo encoder on the 4th axis: absolute.
=0: Type of servo encoder on the 4th axis: incremental.
- APC5** =1: Type of servo encoder on the 5th axis: absolute.
=0: Type of servo encoder on the 5th axis: incremental.

Standard setting: 0 0 0 1 1 1 1 1

Sys Para No.

0	2	2	PRC	DAL						
---	---	---	-----	-----	--	--	--	--	--	--

- DAL** =1: Display of absolute position excludes tool length compensation.
 =0: Display of absolute position includes tool length compensation.
- PRC** =1: Use PRC signal in inputting of tool bias offset and workpiece coordinate system bias.
 =0: Do not use PRC signal in inputting of tool bias offset and workpiece coordinate system bias.

Standard setting: 0 0 0 0 0 0 0 0

Sys Para No.

0	2	3		POSM						
---	---	---	--	------	--	--	--	--	--	--

- POSM** =1: Display the mode on program monitoring page.
 =0: Do not display the mode on program monitoring page.

Standard setting: 0 1 0 0 0 0 0 0

Sys Para No.

0	2	4		NPA						
---	---	---	--	-----	--	--	--	--	--	--

- NPA** =1: Switch to the alarm page in the case of an alarm.
 =0: Do not switch to the alarm page in the case of an alarm.

Standard setting: 0 0 0 0 0 0 0

Sys Para No.

0	2	5	ALM	DGN	GRA	OFT		SYS	PRG	POS
---	---	---	-----	-----	-----	-----	--	-----	-----	-----

- POS** =1: Press "position" again on position interface, to switch the page.
 =0: Press "position" again on position interface, not to switch the page.
- PRG** =1: Press "program" again on program interface, to switch the page.
 =0: Press "program" again on program interface, not to switch the page.
- SYS** =1: Press "system" again on system interface, to switch the page.
 =0: Press "system" again on system interface, not to switch the page.
- OFT** =1: Press "offset" again on offset interface, to switch the page.
 =0: Press "offset" again on offset interface, not to switch the page.
- GRA** =1: Press "graph" again on graph interface, to switch the page.
 =0: Press "graph" again on graph interface, not to switch the page.
- DGN** =1: Press "diagnosis" again on diagnosis interface, to switch the page.
 =0: Press "alarm" again on alarm interface, not to switch the page.

Standard setting: 1 1 1 1 0 1 1 1

Sys Para No.

0	2	6	HELP	PLC				SMDI		PETP
---	---	---	------	-----	--	--	--	------	--	------

- PETP** =1: Press program menu in editing mode, to jump to the program page automatically.
 =0: Press program menu in editing mode, not to jump to the program page automatically.
- SMDI** =1: Press “program” in MDI mode, to jump to the input interface automatically.
 =0: Press “program” in MDI mode, not to jump to the input interface automatically.
- PLC** =1: Press “ladder-shaped” again on PLC interface, to switch the page.
 =0: Press “ladder-shaped” again on PLC interface, not to switch the page.
- HELP** =1: Press “help” again on help interface, to switch the page.
 =0: Press “help” again on help interface, not to switch the page.

Standard setting: 1 1 0 1 0 1 0 1

Sys Para No.

0	2	7				NE9				NE8
---	---	---	--	--	--	-----	--	--	--	-----

- NE8** =1: Forbid editing the subprogram of No.80000 – 89999 programs.
 =0: Do not forbid editing the subprogram of No.80000 – 89999 programs.
- NE9** =1: Forbid editing the subprogram of No.90000 – 99999 programs.
 =0: Allow editing the subprogram of No.90000 – 99999 programs.

Standard setting: 0 0 0 1 0 0 0 1

Sys Para No.

0	2	8	MCL			MKP				
---	---	---	-----	--	--	-----	--	--	--	--

- MKP** =1: Clear the prepared program during execution of M02, M30, or % in MDI mode.
 =0: Do not clear the prepared program during execution of M02, M30, or % in MDI mode.
- MCL** =1: Delete the prepared program when pressing “reset” in MDI mode.
 =0: Do not delete the prepared program when pressing “reset” in MDI mode.

Standard setting: 0 0 0 1 0 0 0 0

Sys Para No.

0	2	9				IWZ	WZO	MCV	GOF	WOF
---	---	---	--	--	--	-----	-----	-----	-----	-----

- WOF** =1: Forbid inputting the tool abrasion bias by the use of MDI keyboard.
=0: Allow inputting the tool abrasion bias by the use of MDI keyboard.
- GOF** =1: Forbid inputting the tool geometric bias by the use of MDI keyboard.
=0: Allow inputting the tool geometric bias by the use of MDI keyboard.
- MCV** =1: Forbid inputting the macro-program variable by the use of MDI keyboard.
=0: Allow inputting the macro-program variable by the use of MDI keyboard.
- WZO** =1: Forbid inputting the workpiece origin bias by the use of MDI keyboard.
=0: Allow inputting the workpiece origin bias by the use of MDI keyboard.
- IWZ** =1: Forbid inputting the workpiece origin bias by the use of MDI keyboard during pause.
=0: Allow inputting the workpiece origin bias by the use of MDI keyboard during pause.

Standard setting: 0 0 0 0 0 0 0 0

Sys Para No.

0	3	0		SFA					
---	---	---	--	-----	--	--	--	--	--

- SFA** =1: Output SF signals even without gear switching.
=0: Do not output SF signals without gear switching.

Standard setting: 0 0 0 0 0 0 0 0

Sys Para No.

0	3	1			FPM			G19	G18	G01
---	---	---	--	--	-----	--	--	-----	-----	-----

- G01** =1: G01 mode when the system is powered on or cleared.
=0: G00 mode when the system is powered on or cleared.
- G18** =1: Plane when the system is powered on or cleared: G18.
=0: Plane when the system is powered on or cleared: G17.
- G19** =1: In the case of G19 mode, set G18 to 0 when G19=1.
=0: Depend on parameter No: 31#1.
- FPM** =1: G99 feed per revolution when the system is powered on or cleared.
=0: G98 feed per revolution when the system is powered on or cleared.

G19	G18	G17, G18, and G19 Modes
0	0	G17 mode (X-Y plane)
0	1	G18 mode (Z-X plane)
1	0	G19 mode (Y-Z plane)

Standard setting: 0 0 0 0 0 0 1 0

Sys Para No.

0	3	2		AD2					
---	---	---	--	-----	--	--	--	--	--

- AD2** =1: The system gives an alarm when the same block has two or more identical addresses.
 =0: The system does not give an alarm when the same block has two or more identical addresses.

Standard setting: 0 1 0 0 0 0 0 0

Sys Para No.

0	3	3	M3B	MHI		M30		M02		TF
---	---	---	-----	-----	--	-----	--	-----	--	----

- TF** =1: Execute the same T code, to output TF signals.
 =0: Execute the same T code, not to output TF signals.
- M02** =1: Return to the start of block when executing M02.
 =0: Do not return to the start of block when executing M02.
- M30** =1: Return to the start of block when executing M30.
 =0: Do not return to the start of block when executing M30.
- MHI** =1: Exchange between strobe signal and ending signal of M/S/T: high-speed mode.
 =0: Exchange between strobe signal and ending signal of M/S/T: usual mode.
- M3B** =1: One block can instruct maximum 3 M codes.
 =0: One block can instruct 1 M code.

Standard setting: 0 0 0 1 0 0 0 0

Sys Para No.

0	3	4	CFH						DWL
---	---	---	-----	--	--	--	--	--	-----

- DWL** =1: G04 is pause per revolution in feed per revolution mode.
 =0: G04 is not pause per revolution in feed per revolution mode.
- CFH** =1: Clear F,H,D codes in the case of reset or emergency stop.
 =0: Reserve F,H,D codes in the case of reset or emergency stop.

Standard setting: 0 0 0 0 0 0 0 0

Sys Para No.

0	3	5	C07		C05	C04	C03	C02	C01	
---	---	---	-----	--	-----	-----	-----	-----	-----	--

- C01** =1: Clear G codes in 01 group in the case of reset or emergency stop.
 =0: Reserve G codes in 01 group in the case of reset or emergency stop.
- C02** =1: Clear G codes in 02 group in the case of reset or emergency stop.
 =0: Reserve G codes in 02 group in the case of reset or emergency stop.
- C03** =1: Clear G codes in 03 group in the case of reset or emergency stop.
 =0: Reserve G codes in 03 group in the case of reset or emergency stop.
- C04** =1: Clear G codes in 04 group in the case of reset or emergency stop.
 =0: Reserve G codes in 04 group in the case of reset or emergency stop.
- C05** =1: Clear G codes in 05 group in the case of reset or emergency stop.
 =0: Reserve G codes in 05 group in the case of reset or emergency stop.
- C07** =1: Clear G codes in 07 group in the case of reset or emergency stop.
 =0: Reserve G codes in 07 group in the case of reset or emergency stop.

Standard setting: 1 0 0 0 0 0 0 0

Sys Para No.

0	3	6	C15	C14	C13	C12	C11	C10	C09	C08
---	---	---	-----	-----	-----	-----	-----	-----	-----	-----

- C08** =1: Clear G codes in 08 group in the case of reset or emergency stop.
=0: Reserve G codes in 08 group in the case of reset or emergency stop.
- C09** =1: Clear G codes in 09 group in the case of reset or emergency stop.
=0: Reserve G codes in 09 group in the case of reset or emergency stop.
- C10** =1: Clear G codes in 10 group in the case of reset or emergency stop.
=0: Reserve G codes in 10 group in the case of reset or emergency stop.
- C11** =1: Clear G codes in 11 group in the case of reset or emergency stop.
=0: Reserve G codes in 11 group in the case of reset or emergency stop.
- C12** =1: Clear G codes in 12 group in the case of reset or emergency stop.
=0: Reserve G codes in 12 group in the case of reset or emergency stop.
- C13** =1: Clear G codes in 13 group in the case of reset or emergency stop.
=0: Reserve G codes in 13 group in the case of reset or emergency stop.
- C14** =1: Clear G codes in 14 group in the case of reset or emergency stop.
=0: Reserve G codes in 14 group in the case of reset or emergency stop.
- C15** =1: Clear G codes in 15 group in the case of reset or emergency stop.
=0: Reserve G codes in 15 group in the case of reset or emergency stop.

Standard setting: 0 0 0 0 0 0 1 1

Sys Para No.

0	3	7	SCS	CSS	CSZR		SOC	RSC	BDP	SCRW
---	---	---	-----	-----	------	--	-----	-----	-----	------

- SCRW** =1: The pitch error compensation is valid.
=0: The pitch error compensation is invalid.
- BDP** =1: Use bi-direction pitch error compensation.
=0: Do not use bi-direction pitch error compensation.
- RSC** =1: Calculate the datum coordinate of G96 spindle speed as current point in the case of G0 rapid positioning.
=0: Calculate the datum coordinate of G96 spindle speed as end point in the case of G0 rapid positioning.
- SOC** =1: G96 spindle speed is suppressed after spindle magnification.
=0: G96 spindle speed is suppressed before spindle magnification.
- CSZR** =1: The reference point return of CS contouring control is valid.
=0: The reference point return of CS contouring control is invalid.
- CSS** =1: Conduct Cs contouring control in each spindle.
=0: Do not conduct Cs contouring control in any spindle.
- SCS** =1: Use Cs contouring control.
=0: Do not use Cs contouring control.

Standard setting: 1 0 0 0 0 0 0 0

Sys Para No.

0	3	8		SGB	GTT	FLRE	FLR	EOV	MPP	SAR
---	---	---	--	------------	------------	-------------	------------	------------	------------	------------

- SAR** =1: Check the spindle speed arrival signal.
 =0: Do not the spindle speed arrival signal.
- MPP** =1: In multi-spindle control, the program selects a program by instructing P codes.
 =0: In multi-spindle control, the program selects a program not instructing P codes.
- EOV** =1: Use the magnification signal of each spindle.
 =0: Do not the magnification signal of any spindle.
- FLR** =1: The rate of allowance (q) and the rate of change (r) set in spindle speed fluctuation detection are expressed in 0.1%.
 =0: The rate of allowance (q) and the rate of change (r) set in spindle speed fluctuation detection are expressed in 1%.
- FLRE** =1: The spindle speed fluctuation detection is valid.
 =0: The spindle speed fluctuation detection is invalid.
- GTT** =1: Spindle gear: T type.
 =0: Spindle gear: M type.
- SGB** =1: M-type gear switching mode: speed at each gear switching point (mode B).
 =0: M-type gear switching mode: maximum speed of each gear (mode A).

Standard setting: 0 0 1 0 0 0 0 0

Sys Para No.

0	3	9	THSY	THQR	THST			DIA	TLCM	
---	---	---	-------------	-------------	-------------	--	--	------------	-------------	--

- TLCM** =1: The tool length compensation can be modified during program execution.
 =0: The tool length compensation cannot be modified during program execution.
- DIA** =1: Adopt the diameter method for programming.
 =0: Adopt the radius method for programming.
- THST** =1: Spindle pulse sampling in the case of thread cutting: average.
 =0: Spindle pulse sampling in the case of thread cutting: original.
- THQR** =1: In thread tail, movement in stub axle positioning mode is valid.
 =0: In thread tail, movement in stub axle positioning mode is invalid.
- THSY** =1: Synchronize with mode B during thread cutting.
 =0: Synchronize with mode A during thread cutting.

Standard setting: 0 0 0 0 0 1 0 0

Sys Para No.

0	4	0	ODI		THST	TPRT		CCN		SUP
---	---	---	-----	--	------	------	--	-----	--	-----

- SUP** =1: Type of knife picking in tool radius compensation: B type.
=0: Type of knife picking in tool radius compensation: A type.
- CCN** =1: Cancel radius compensation when G28 command moves to the midpoint.
=0 Reserve radius compensation when G28 command moves to the midpoint.
- TPRT** =1: Linear speed controlling in thread cutting uses constant acceleration.
=0: Linear speed controlling in thread cutting uses constant time constant.
- THST** =1: Mode of threaded screw head signal reading: read once only.
=0: Mode of threaded screw head signal reading: read every time.
- ODI** =1: The tool radius offset is set according to the diameter.
=0: The tool radius offset is set according to the radius.

Standard setting: 0 0 1 1 0 1 0 1

Sys Para No.

0	4	1		CNI	G39		PUIT			
---	---	---	--	-----	-----	--	------	--	--	--

- PUIT** =1: Number parameters are inputted and displayed according to Bit Para NO.0#2 INI.
=0: Number parameters are inputted and displayed in metric system.
- G39** =1: The corner arc function is valid in radius compensation.
=0: The corner arc function is invalid in radius compensation.
- CNI** =1: Do interference checking in radius compensation.
=0: Do not do interference checking in radius compensation.

Standard setting: 0 1 1 0 0 0 0 0

Sys Para No.

0	4	2			RD2	RD1				
---	---	---	--	--	-----	-----	--	--	--	--

- RD1** =1: Set the retracting direction of G76 and G87: negative.
=0: Set the retracting direction of G76 and G87: positive.
- RD2** =1: Set the retracting axis of G76 and G87: the 2nd axis.
=0: Set the retracting axis of G76 and G87: the 1st axis.

Standard setting: 0 0 0 0 0 0 0 0

Sys Para No.

0	4	3					PLS		PDI
---	---	---	--	--	--	--	-----	--	-----

- PDI** =1: Use the 2nd axis of plane in polar coordinate interpolation when it is specified by diameter.
=0: Use the 2nd axis of plane in polar coordinate interpolation when it is specified by radius.
- RD2** =1: Use the polar coordinate interpolation offset.
=0: Do not use the polar coordinate interpolation offset.

Standard setting: 0 0 0 0 0 0 1 0

Sys Para No.

0	4	4			PCP	DOV	RTR			
---	---	---	--	--	-----	-----	-----	--	--	--

- RTR** =1: The drilling pattern of G83 and G87 is high-speed deep-hole drilling-cutting cycle.
 =0: The drilling pattern of G83 and G87 is deep-hole drilling-cutting cycle.
- DOV** =1: During rigid tapping tool retracting, magnification is valid.
 =0: During rigid tapping tool retracting, magnification is invalid.
- PCP** =1: Tapping is high-speed deep-hole tapping cycle.
 =0: Tapping is not high-speed deep-hole tapping cycle.

Standard setting: 0 0 0 0 0 0 0 0

Sys Para No.

0	4	5				OVS	OVU	TDR		NIZ
---	---	---	--	--	--	-----	-----	-----	--	-----

- NIZ** =1: Do smooth processing of rigid tapping.
 =0: Do not smooth processing of rigid tapping.
- TDR** =1: the same time constant used in tool feeding and retracting of rigid tapping
 =0: not the same constant used in tool feeding and retracting of rigid tapping
- OVU** =1: magnification in tool retracting of rigid tapping in 10%.
 =0: magnification in tool retracting of rigid tapping in 1%.
- OVS** =1: in rigid tapping, feed rate: magnification canceling signal valid
 =0: in rigid tapping, feed rate: magnification canceling signal invalid

Standard setting: 0 0 0 0 0 0 0 0

0	4	7				SCA5	SCA4	SCA3	SCA2	SCA1
---	---	---	--	--	--	------	------	------	------	------

- SCA1** =1: the 1st axis synchronized control determined by signal
 =0: the 1st axis synchronous control: synchronized sooner or later
- SCA2** =1: the 2nd axis synchronous control: synchronization determined by signal
 =0: the 2nd axis synchronous control: synchronized sooner or later
- SCA3** =1: the 3rd axis synchronous control: synchronization determined by signal
 =0: the 3rd axis synchronous control: synchronized sooner or later
- SCA4** =1: the 4th axis synchronous control: synchronization determined by signal
 =0: the 4th axis synchronous control: synchronized sooner or later
- SCA5** =1: the 5th axis synchronous control: synchronization determined by signal
 =0: the 5th axis synchronous control: synchronized sooner or later

Standard setting: 0 0 0 0 0 0 0 0

Sys Para No.

0	4	8								MDL
---	---	---	--	--	--	--	--	--	--	-----

- MDL** =1: The G code for one-way orientation is set to a modal code.
 =0: The G code for one-way orientation is not set to a modal code.

Standard setting: 0 0 0 0 0 0 0 0

Sys Para No.

0	4	9									RPST
---	---	---	--	--	--	--	--	--	--	--	------

- RPST** =1: During restart, the program moves in 01 mode.
 =0: During restart, the program moves at dry running speed in 01 mode.

Standard setting: 0 0 0 0 0 0 0 0

Sys Para No.

0	5	0			SIM						REL	
---	---	---	--	--	------------	--	--	--	--	--	------------	--

- REL** =1: relative position setting of index workbench: in 360°
 =0: relative position setting of index workbench: out of 360°
- SIM** =1: Give an alarm if indexing code and other control axis code are in the same block.
 =0: Do not give an alarm if indexing code and other control axis code are in the same block.

Standard setting: 0 1 0 0 0 0 0 0

Sys Para No.

0	5	1	MDLY		SBM					
---	---	---	-------------	--	------------	--	--	--	--	--

- SBM** =1: single blocks allowed in macro-program command statements
 =0: single blocks not allowed in macro-program command statements
- MDLY** =1: deferred in macro-program command statements
 =0: not deferred in macro-program command statements

Standard setting: 0 0 1 0 0 0 0 0

Sys Para No.

0	5	2	CLV	CCV							PRTC	
---	---	---	------------	------------	--	--	--	--	--	--	-------------	--

- PRTC** =1: parts arriving signal (PRTSF) set to 0 in reset
 =0: parts arriving signal (PRTSF) not set to 0 in reset
- CCV** =1: macro-program public variables #100 - #199 cleared after reset
 =0: macro-program public variables #100 - #199 not cleared after reset
- CLV** =1: macro-program local variables #1 - #50 cleared after reset
 =0: macro-program local variables #1 - #50 not cleared after reset

Standard setting: 0 0 0 0 0 0 0 0

Sys Para No.

0	5	3					LAD3	LDA2	LAD1	LAD0
---	---	---	--	--	--	--	-------------	-------------	-------------	-------------

LAD0~LAD3 are binary family parameters. When it is 0, use No.0 ladder graph; when it is 1~15, use No.0~15 ladder graphs.

Standard setting: 0 0 0 0 0 0 1 1

Sys Para No.

0	5	4	OPRG	PRGS						
----------	----------	----------	-------------	-------------	--	--	--	--	--	--

- PRGS** =1: program switch open initially
=0: program switch closed initially
- OPRG** =1: For debugging or higher permission, one-touch input/output is valid for part program.
=0: For debugging or higher permission, one-touch input/output is invalid for part program.

Standard setting: 0 1 0 0 0 0 0 0

Sys Para No.

0	5	5						GPRG	CANT
----------	----------	----------	--	--	--	--	--	-------------	-------------

- CANT** =1: one-piece processing time cleared automatically
=0: one-piece processing time not cleared automatically
- GPRG** =1: programming with templates valid
=0: programming with template invalid

Standard setting: 0 0 0 0 0 0 0 0

Sys Para No.

0	5	6	HNG5	HNG4	HNG3	HNG2	HNG1			HPF
----------	----------	----------	-------------	-------------	-------------	-------------	-------------	--	--	------------

- HPF** =1: manual pulse shift running automatically
=0: manual pulse shift not running automatically
- HNG1** =1: the 1st axis moving and manual pulse generator turning in different directions
=0: the 1st axis moving and manual pulse generator turning in the same direction
- HNG2** =1: the 2nd axis moving and manual pulse generator turning in different directions
=0: the 2nd axis moving and manual pulse generator turning in the same direction
- HNG3** =1: the 3rd axis moving and manual pulse generator turning in different directions
=0: the 3rd axis moving and manual pulse generator turning in the same direction
- HNG4** =1: the 4th axis moving and manual pulse generator turning in different directions
=0: the 4th axis moving and manual pulse generator turning in the same direction
- HNG5** =1: the 5th axis moving and manual pulse generator turning in different directions
=0: the 5th axis moving and manual pulse generator turning in the same direction

Standard setting: 0 0 0 0 0 0 0 0

Sys Para No.

0	5	7				PLW5	PLW4	PLW3	PLW2	PLW1
---	---	---	--	--	--	------	------	------	------	------

- PLW1** =1: the 1st axis pulse width variable with speed
=0: the 1st axis pulse width constant for 1 μs
- PLW2** =1: the 2nd axis pulse width variable with speed
=0: the 2nd axis pulse width constant for 1 μs
- PLW3** =1: the 3rd axis pulse width variable with speed
=0: the 3rd axis pulse width constant for 1 μs
- PLW4** =1: the 4th axis pulse width variable with speed
=0: the 4th axis pulse width constant for 1 μs
- PLW5** =1: the 5th axis pulse width variable with speed
=0: the 5th axis pulse width constant for 1 μs

Standard setting: 0 0 0 0 0 0 0 0

Sys Para No.

0	5	8				NEG 5	NEG 4	NEG 3	NEG 2	NEG 1
---	---	---	--	--	--	-------	-------	-------	-------	-------

- PLW1** =1: the 1st axis neglected
=0: the 1st axis not neglected
- PLW2** =1: the 2nd axis neglected
=0: the 2nd axis not neglected
- PLW3** =1: the 3rd axis neglected
=0: the 3rd axis not neglected
- PLW4** =1: the 4th axis neglected
=0: the 4th axis not neglected
- PLW5** =1: the 5th axis neglected
=0: the 5th axis not neglected

Standard setting: 0 0 0 0 1 0 1 0

Sys Para No.

0	5	9		LEDT						
---	---	---	--	------	--	--	--	--	--	--

- LEDT** =1: external program locking signal signal valid
=0: external program locking signal signal invalid

Standard setting: 0 0 0 0 0 0 0 0

Sys Para No.

0	6	0	PMCA	PMCP				PMCS		
---	---	---	------	------	--	--	--	------	--	--

- PMCS** =1: PMC-axis specified by G signal
=0: PMC-axis not specified by G signal
- PMCP** =1: PMC-axis zero return mode with one revolution of signals
=0: PMC-axis zero return mode without one revolution of signals
- PMCA** =1: Give an alarm when PMC-axis not returning to reference point commands the mechanical coordinate selection mode.
=0: Do not give an alarm when PMC-axis not returning to reference point commands the mechanical coordinate selection mode.

Standard setting: 0 0 0 0 0 0 0 0

Sys Para No.

0	6	1	FALM	LALM	EALM	SALM	AALM			SSC
---	---	---	------	------	------	------	------	--	--	-----

- SSC** =1: Use constant cycle speed control
 =0: Do not use constant cycle speed control.
- AALM** =1: Neglect the external user alarm.
 =0: Do not neglect the external user alarm.
- SALM** =1: Neglect the spindle drive unit alarm.
 =0: Do not neglect the spindle drive unit alarm.
- EALM** =1: Neglect the emergency stop alarm.
 =0: Do not neglect the emergency stop alarm.
- LALM** =1: Neglect the hard limit alarm.
 =0: Do not neglect the hard limit alarm.
- FALM** =1: Neglect the feed axis drive unit alarm.
 =0: Do not neglect the feed axis drive unit alarm.

Standard setting: 0 0 0 0 0 0 0 0

2. Data Parameters

Parameter No.	Parameter Definition	Default
0000	I/O channel, input-output device (1:RS232 2:USB)	2

Setting range: 1 ~ 2

It is set to 0 or 1 when CNC communicates with PC via RS232 interface; set to 2 when CNC is connected to U disk.

0005	CNC controlled axes	3
------	---------------------	---

Setting range: 3 ~ 5

0006	System language selection (0: Chinese; 1: English)	0
------	--	---

Setting range: 0 ~ 1

0007	Days ahead of the timed shutdown expiration reminder	7
------	--	---

Setting range: 0 ~ 99

0008	Size of MDT data packet at Ethernet bus slave station	16
------	---	----

Setting range: 0 ~ 20

0009	Max. re-transmission times of Ethernet bus	10
------	--	----

Setting range: 0 ~ 30

0010	the 1st axis offset from external workpiece origin	0.0000
------	--	--------

Setting range: -19999.9998 ~ 19999.9998 (mm)

0011	the 2nd axis offset from external workpiece origin	0.0000
------	--	--------

Setting range: -9999.9999 ~ 9999.9999 (mm)

0012	the 3rd axis offset from external workpiece origin	0.0000
------	--	--------

Setting range: -9999.9999 ~ 9999.9999 (mm)

0013	the 4th axis offset from external workpiece origin	0.0000
------	--	--------

Setting range: -9999.9999 ~ 9999.9999 (mm)

0014	the 5th axis offset from external workpiece origin	0.0000
------	--	--------

Setting range: -9999.9999 ~ 9999.9999 (mm)

0015	Workpiece origin offset on the 1st axis of G54	0.0000
------	--	--------

Setting range: -19999.9998 ~ 19999.9998 (mm)

0016	Workpiece origin offset on the 2nd axis of G54	0.0000
------	--	--------

Setting range: -9999.9999 ~ 9999.9999 (mm)

0017	Workpiece origin offset on the 3rd axis of G54	0.0000
------	--	--------

Setting range: -9999.9999 ~ 9999.9999 (mm)

0018	Workpiece origin offset on the 4th axis of G54	0.0000
------	--	--------

Setting range: -9999.9999 ~ 9999.9999 (mm)

0019	Workpiece origin offset on the 5th axis of G54	0.0000
------	--	--------

Setting range: -9999.9999 ~ 9999.9999 (mm)

0020	Workpiece origin offset on the 1st axis of G55	0.0000
------	--	--------

Setting range: -19999.9998 ~ 19999.9998 (mm)

0021	Workpiece origin offset on the 2nd axis of G55	0.0000
------	--	--------

Setting range: -19999.9999 ~ 19999.9999 (mm)

0022	Workpiece origin offset on the 3rd axis of G55	0.0000
------	--	--------

Setting range: -9999.9999 ~ 9999.9999 (mm)

0023	Workpiece origin offset on the 4th axis of G55	0.0000
------	--	--------

Setting range: -9999.9999 ~ 9999.9999 (mm)

0024	Workpiece origin offset on the 5th axis of G55	0.0000
------	--	--------

Setting range: -9999.9999 ~ 9999.9999 (mm)

0025	Workpiece origin offset on the 1st axis of G56	0.0000
------	--	--------

Setting range: -19999.9998 ~ 19999.9998 (mm)

0026	Workpiece origin offset on the 2nd axis of G56	0.0000
------	--	--------

Setting range: -9999.9999 ~ 9999.9999 (mm)

0027	Workpiece origin offset on the 3rd axis of G56	0.0000
------	--	--------

Setting range: -9999.9999 ~ 9999.9999 (mm)

0028	Workpiece origin offset on the 4th axis of G56	0.0000
------	--	--------

Setting range: -9999.9999 ~ 9999.9999 (mm)

0029	Workpiece origin offset on the 5th axis of G56	0.0000
------	--	--------

Setting range: -9999.9999 ~ 9999.9999 (mm)

0030	Workpiece origin offset on the 1st axis of G57	0.0000
------	--	--------

Setting range: -19999.9998 ~ 19999.9998 (mm)

0031	Workpiece origin offset on the 2nd axis of G57	0.0000
------	--	--------

Setting range: -9999.9999 ~ 9999.9999 (mm)

0032	Workpiece origin offset on the 3rd axis of G57	0.0000
------	--	--------

Setting range: -9999.9999 ~ 9999.9999 (mm)

0033	Workpiece origin offset on the 4th axis of G57	0.0000
------	--	--------

Setting range: -9999.9999 ~ 9999.9999 (mm)

0034	Workpiece origin offset on the 5th axis of G57	0.0000
------	--	--------

Setting range: -9999.9999 ~ 9999.9999 (mm)

0035	Workpiece origin offset on the 1st axis of G58	0.0000
------	--	--------

Setting range: -19999.9998 ~ 19999.9998 (mm)

0036	Workpiece origin offset on the 2nd axis of G58	0.0000
------	--	--------

Setting range: -9999.9999 ~ 9999.9999 (mm)

0037	Workpiece origin offset on the 3rd axis of G58	0.0000
------	--	--------

Setting range: -9999.9999 ~ 9999.9999 (mm)

0038	Workpiece origin offset on the 4th axis of G58	0.0000
------	--	--------

Setting range: -9999.9999 ~ 9999.9999 (mm)

0039	Workpiece origin offset on the 5th axis of G58	0.0000
------	--	--------

Setting range: -9999.9999 ~ 9999.9999 (mm)

0040	Workpiece origin offset on the 1st axis of G59	0.0000
------	--	--------

Setting range: -19999.9998 ~ 19999.9998 (mm)

0041	Workpiece origin offset on the 2nd axis of G59	0.0000
------	--	--------

Setting range: -9999.9999 ~ 9999.9999 (mm)

0042	Workpiece origin offset on the 3rd axis of G59	0.0000
------	--	--------

Setting range: -9999.9999 ~ 9999.9999 (mm)

0043	Workpiece origin offset on the 4th axis of G59	0.0000
------	--	--------

Setting range: -9999.9999 ~ 9999.9999 (mm)

0044	Workpiece origin offset on the 5th axis of G59	0.0000
------	--	--------

Setting range: -9999.9999 ~ 9999.9999 (mm)

0045	Machine coordinate of the 1st reference point on the 1st axis	0.0000
------	---	--------

Setting range: -19999.9998 ~ 19999.9998 (mm)

0046	Machine coordinate of the 1st reference point on the 2nd axis	0.0000
------	---	--------

Setting range: -9999.9999 ~ 9999.9999 (mm)

0047	Machine coordinate of the 1st reference point on the 3rd axis	0.0000
------	---	--------

Setting range: -9999.9999 ~ 9999.9999 (mm)

0048	Machine coordinate of the 1st reference point on the 4th axis	0.0000
------	---	--------

Setting range: -9999.9999 ~ 9999.9999 (mm)

0049	Machine coordinate of the 1st reference point on the 5th axis	0.0000
------	---	--------

Setting range: -9999.9999 ~ 9999.9999 (mm)

0050	Machine coordinate of the 2nd reference point on the 1st axis	0.0000
------	---	--------

Setting range: -19999.9998 ~ 19999.9998 (mm)

0051	Machine coordinate of the 2nd reference point on the 2nd axis	0.0000
------	---	--------

Setting range: -9999.9999 ~ 9999.9999 (mm)

0052	Machine coordinate of the 2nd reference point on the 3rd axis	0.0000
------	---	--------

Setting range: -9999.9999 ~ 9999.9999 (mm)

0053	Machine coordinate of the 2nd reference point on the 4th axis	0.0000
------	---	--------

Setting range: -9999.9999 ~ 9999.9999 (mm)

0054	Machine coordinate of the 2nd reference point on the 5th axis	0.0000
------	---	--------

Setting range: -9999.9999 ~ 9999.9999 (mm)

0055	Machine coordinate of the 3rd reference point on the 1st axis	0.0000
------	---	--------

Setting range: -19999.9998 ~ 19999.9998 (mm)

0056	Machine coordinate of the 3rd reference point on the 2nd axis	0.0000
------	---	--------

Setting range: -9999.9999 ~ 9999.9999 (mm)

0057	Machine coordinate of the 3rd reference point on the 3rd axis	0.0000
------	---	--------

Setting range: -9999.9999 ~ 9999.9999 (mm)

Appendix I List of Parameters

0058	Machine coordinate of the 3rd reference point on the 4th axis	0.0000
------	---	--------

Setting range: -9999.9999 ~ 9999.9999 (mm)

0059	Machine coordinate of the 3rd reference point on the 5th axis	0.0000
------	---	--------

Setting range: -9999.9999 ~ 9999.9999 (mm)

0060	Machine coordinate of the 4th reference point on the 1st axis	0.0000
------	---	--------

Setting range: -19999.9998 ~ 19999.9998 (mm)

0061	Machine coordinate of the 4th reference point on the 2nd axis	0.0000
------	---	--------

Setting range: -9999.9999 ~ 9999.9999 (mm)

0062	Machine coordinate of the 4th reference point on the 3rd axis	0.0000
------	---	--------

Setting range: -9999.9999 ~ 9999.9999 (mm)

0063	Machine coordinate of the 4th reference point on the 4th axis	0.0000
------	---	--------

Setting range: -9999.9999 ~ 9999.9999 (mm)

0064	Machine coordinate of the 4th reference point on the 5th axis	0.0000
------	---	--------

Setting range: -9999.9999 ~ 9999.9999 (mm)

0066	Storage stroke testing 1: negative boundary coordinate on the 1st axis	-19998
------	--	--------

Setting range: -19999.9998 ~ 19999.9998 (mm)

0067	Storage stroke testing 1: positive boundary coordinate on the 1st axis	19998
------	--	-------

Setting range: -19999.9998 ~ 19999.9998 (mm)

0068	Storage stroke testing 1: negative boundary coordinate on the 2nd axis	-9999
------	--	-------

Setting range: -9999.9999 ~ 9999.9999 (mm)

0069	Storage stroke testing 1: positive boundary coordinate on the 2nd axis	9999
------	--	------

Setting range: -9999.9999 ~ 9999.9999 (mm)

0070	Storage stroke testing 1: negative boundary coordinate on the 3rd axis	-9999
------	--	-------

Setting range: -9999.9999 ~ 9999.9999 (mm)

0071	Storage stroke testing 1: positive boundary coordinate on the 3rd axis	9999
------	--	------

Setting range: -9999.9999 ~ 9999.9999 (mm)

0072	Storage stroke testing 1: negative boundary coordinate on the 4th axis	-9999
------	--	-------

Setting range: -9999.9999 ~ 9999.9999 (mm)

0073	Storage stroke testing 1: positive boundary coordinate on the 4th axis	9999
------	--	------

Setting range: -9999.9999 ~ 9999.9999 (mm)

0074	Storage stroke testing 1: negative boundary coordinate on the 5th axis	-9999
------	--	-------

Setting range: -9999.9999 ~ 9999.9999 (mm)

0075	Storage stroke testing 1: positive boundary coordinate on the 5th axis	9999
------	--	------

Setting range: -9999.9999 ~ 9999.9999 (mm)

0076	Storage stroke testing 2: negative boundary coordinate on the 1st axis	-19998
------	--	--------

Setting range: -19999.9989 ~ 19999.9998 (mm)

0077	Storage stroke testing 2: positive boundary coordinate on the 1st axis	19998
------	--	-------

Setting range: -1999.9998 ~ 19999.9998 (mm)

0078	Storage stroke testing 2: negative boundary coordinate on the 2nd axis	-9999
------	--	-------

Setting range: -9999.9999 ~ 9999.9999 (mm)

0079	Storage stroke testing 2: positive boundary coordinate on the 2nd axis	9999
------	--	------

Setting range: -9999.9999 ~ 9999.9999 (mm)

0080	Storage stroke testing 2: negative boundary coordinate on the 3rd axis	-9999
------	--	-------

Setting range: -9999.9999 ~ 9999.9999 (mm)

0081	Storage stroke testing 2: positive boundary coordinate on the 3rd axis	9999
------	--	------

Setting range: -9999.9999 ~ 9999.9999 (mm)

0082	Storage stroke testing 2: negative boundary coordinate on the 4th axis	-9999
------	--	-------

Setting range: -9999.9999 ~ 9999.9999 (mm)

0083	Storage stroke testing 2: positive boundary coordinate on the 4th axis	9999
------	--	------

Setting range: -9999.9999 ~ 9999.9999 (mm)

0084	Storage stroke testing 2: negative boundary coordinate on the 5th axis	-9999
------	--	-------

Setting range: -9999.9999 ~ 9999.9999 (mm)

0085	Storage stroke testing 2: positive boundary coordinate on the 5th axis	9999
------	--	------

Setting range: -9999.9999 ~ 9999.9999 (mm)

0086	Dry running speed	2000
------	-------------------	------

Setting range: 0 ~ 9999 (mm/min)

Appendix I List of Parameters

0087	Cutting feed speed when the machine is powered on	100
------	---	-----

Setting range: 0 ~ 9999 (mm/min)

0088	G0 rapid positioning speed on the 1st axis	4000
------	--	------

Setting range:

Metric: 1 ~ 30,000 (mm/min)
 British: 1 ~ 30,000/ 25.4 (inch/min)
 Rotating axis: 1 ~ 30,000 (deg/min)

0089	G0 fast running speed on the 2nd axis	8000
------	---------------------------------------	------

Setting range:

Metric: 0 ~ 30,000 (mm/min)
 British: 0 ~ 30,000/ 25.4 (inch/min)
 Rotating axis: 0 ~ 30,000 (deg/min)

0090	G0 fast running speed on the 3rd axis	8000
------	---------------------------------------	------

Setting range:

Metric: 0 ~ 30,000 (mm/min)
 British: 0 ~ 30,000/ 25.4 (inch/min)
 Rotating axis: 0 ~ 30,000 (deg/min)

0091	G0 fast running speed on the 4th axis	8000
------	---------------------------------------	------

Setting range:

Metric: 0 ~ 30,000 (mm/min)
 British: 0 ~ 30,000/ 25.4 (inch/min)
 Rotating axis: 0 ~ 30,000 (deg/min)

0092	G0 fast running speed on the 5th axis	8000
------	---------------------------------------	------

Setting range:

Metric: 0 ~ 30,000 (mm/min)
 British: 0 ~ 30,000/ 25.4 (inch/min)
 Rotating axis: 0 ~ 30,000 (deg/min)

0093	Rapid magnification is Fo speed (universal for all axes)	30
------	--	----

Setting range: 1 ~ 1000 (mm/min)

0094	Maximum speed of rapid positioning (universal for all axes)	8000
------	---	------

Setting range: 300 ~ 30,000(mm/min)

0095	Minimum speed of rapid positioning (universal for all axes)	0
------	---	---

Setting range: 0 ~ 300 (mm/min)

0096	Maximum speed of cutting feed (universal for all axes)	8000
------	--	------

Setting range: 300 ~ 30,000(mm/min)

0097	Minimum speed of cutting feed (universal for all axes)	0
------	--	---

Setting range: 0 ~ 300 (mm/min)

0098	Manual (JOG) feed speed on each axis (universal for all axes)	2000
------	---	------

Setting range: 0 ~ 30,000 (mm/min)

0099	(FL) speed in acquisition of Z pulse signal (universal for all axes)	100
------	--	-----

Setting range: 1 ~ 200 (mm/min)

0100	Rapid movement speed of returning to reference point on the 1st axis	2000
------	--	------

Setting range: 0 ~ 9999 (mm/min)

0101	Rapid movement speed of returning to reference point on the 2nd axis	4000
------	--	------

Setting range: 0 ~ 9999 (mm/min)

0102	Rapid movement speed of returning to reference point on the 3rd axis	4000
------	--	------

Setting range: 0 ~ 9999 (mm/min)

0103	Rapid movement speed of returning to reference point on the 4th axis	4000
------	--	------

Setting range: 0 ~ 9999 (mm/min)

0104	Rapid movement speed of returning to reference point on the 5th axis	4000
------	--	------

Setting range: 0 ~ 9999 (mm/min)

0105	Speed of manual (JOG) continuous feed on the 1st axis	2000
------	---	------

Setting range: 0 ~ 30,000 (mm/min)

0106	Speed of manual (JOG) continuous feed on the 2nd axis	2000
------	---	------

Setting range: 0 ~ 30,000 (mm/min)

0107	Speed of manual (JOG) continuous feed on the 3rd axis	2000
------	---	------

Setting range: 0 ~ 30,000 (mm/min)

0108	Speed of manual (JOG) continuous feed on the 4th axis	2000
------	---	------

Setting range: 0 ~ 30,000 (mm/min)

0109	Speed of manual (JOG) continuous feed on the 5th axis	2000
------	---	------

Setting range: 0 ~ 30,000 (mm/min)

0110	Rapid positioning acceleration (mm/s ²) on the 1st axis	5000
------	---	------

Setting range: 1 ~ 9999 (mm/s²)

0111	Rapid positioning acceleration (mm/s ²) on the 2nd axis	5000
------	---	------

Setting range: 1 ~ 9999 (mm/s²)

0112	Rapid positioning acceleration (mm/s ²) on the 3rd axis	5000
------	---	------

Setting range: 1 ~ 9999 (mm/s²)

0113	Rapid positioning acceleration (mm/s ²) on the 4th axis	5000
------	---	------

Setting range: 1 ~ 9999 (mm/s²)

0114	Rapid positioning acceleration (mm/s ²) on the 5th axis	5000
------	---	------

Setting range: 1 ~ 9999 (mm/s²)

0115	S-type speed controlling time constant T1 in rapid positioning on the 1st axis	70
------	--	----

Setting range: 0 ~ 400 (ms)

0116	S-type speed controlling time constant T1 in rapid positioning on the 2nd axis	70
------	--	----

Setting range: 0 ~ 400 (ms)

0117	S-type speed controlling time constant T1 in rapid positioning on the 3rd axis	70
------	--	----

Setting range: 0 ~ 400 (ms)

0118	S-type speed controlling time constant T1 in rapid positioning on the 4th axis	70
------	--	----

Setting range: 0 ~ 400 (ms)

0119	S-type speed controlling time constant T1 in rapid positioning on the 5th axis	70
------	--	----

Setting range: 0 ~ 400 (ms)

0120	S-type speed controlling time constant T2 in rapid positioning on the 1st axis	30
------	--	----

Setting range: 0 ~ 400 (ms)

0121	S-type speed controlling time constant T2 in rapid positioning on the 2nd axis	30
------	--	----

Setting range: 0 ~ 400 (ms)

0122	S-type speed controlling time constant T2 in rapid positioning on the 3rd axis	30
------	--	----

Setting range: 0 ~ 400 (ms)

0123	S-type speed controlling time constant T2 in rapid positioning on the 4th axis	30
------	--	----

Setting range: 0 ~ 400 (ms)

0124	S-type speed controlling time constant T2 in rapid positioning on the 5th axis	30
------	--	----

Setting range: 0 ~ 400 (ms)

0125	L-type time constant of speed controlling before cutting feed	100
------	---	-----

Setting range: 3 ~ 400 (ms)

0126	S-type time constant speed controlling before cutting feed	100
------	--	-----

Setting range: 3 ~ 400 (ms)

0127	L-type time constant of speed controlling after cutting feed	80
------	--	----

Setting range: 3 ~ 400 (ms)

0128	E-type time constant of speed controlling after cutting feed	60
------	--	----

Setting range: 3 ~ 400 (ms)

0129	Exponential speed controlling FL speed	10
------	--	----

Setting range: 0 ~ 9999 (mm/min)

0130	Pre-interpolation maximum combined blocks	0
------	---	---

Setting range: 0 ~ 10

0131	Cutting feed positioning accuracy	0.03
------	-----------------------------------	------

Setting range: 0.001 ~ 0.5 (mm)

0132	Arc interpolation control accuracy	0.03
------	------------------------------------	------

Setting range: 0 ~ 0.5 (mm)

0133	Pre-interpolation contouring control accuracy	0.01
------	---	------

Setting range: 0.0010 ~ 0.5000 (mm)

0134	Acceleration of linear speed controlling before interpolation in predictive control mode	2000
------	--	------

Setting range: 0 ~ 5000 (mm/s²)

0135	S-type constant of speed controlling before interpolation in predictive control mode	100
------	--	-----

Setting range: 0 ~ 400 (ms)

0136	Time constant of linear speed controlling after interpolation in predictive control mode	80
------	--	----

Setting range: 0 ~ 400 (ms)

0137	Exponential time constant of speed controlling after interpolation in predictive control	60
------	--	----

Setting range: 0 ~ 400 (ms)

0138	Exponential speed controlling FL speed of cutting feed in predictive control	10
------	--	----

Setting range: 0 ~ 400 (ms)

Appendix I List of Parameters

0139	Contouring control accuracy in predictive control mode	0.01
------	--	------

Setting range: 0 ~ 0.5 (mm)

0140	Combined blocks in predictive control mode	0
------	--	---

Setting range: 0 ~ 10

0141	Positioning accuracy in predictive control mode	0.05
------	---	------

Setting range: 0 ~ 0.5 (mm)

0142	Maximum acceleration/deceleration (mm/s ²) in rapid positioning	5000
------	---	------

Setting range: 1 ~ 9999 (mm/s²)

0143	Acceleration/deceleration FL speed (mm/min) in rapid positioning	30
------	--	----

Setting range: 0 ~ 9999 (mm/min)

0144	In predictive control mode, critical angle between two blocks in automatic corner deceleration	5
------	--	---

Setting range: 2 ~ 178 (°)

0145	In predictive control mode, minimum feed speed in automatic corner deceleration	120
------	---	-----

Setting range: 10 ~ 1000 (mm/min)

0146	In predictive control mode, allowable variation of each axis in speed difference deceleration	80
------	---	----

Setting range: 60 ~ 1000

0147	In predictive control mode, cutting accuracy level	2
------	--	---

Setting range: 0 ~ 8

0148	Acceleration limit outside arc interpolation	1000
------	--	------

Setting range: 100 ~ 5000

0149	Lower speed limit on acceleration block level outside arc interpolation	200
------	---	-----

Setting range: 0 ~ 2000 (mm/min)

0150	Suppressed time constant in cutting feed acceleration	50
------	---	----

Setting range: 0 ~ 1000 (ms)

0151	Maximum suppressed speed of manual pulse incomplete running mode	2000
------	--	------

Setting range: 0 ~ 3000 (mm/min)

0152	Time constant in manual pulse linear speed controlling	120
------	--	-----

Setting range: 0 ~ 400 (ms)

0153	Exponential speed controlling time constant in manual pulse/single-step mode	80
------	--	----

Setting range: 0 ~ 400 (ms)

0154	Highest-speed pulses of periodic (4ms) sampling in manual pulse trial cutting	1000
------	---	------

Setting range: 1 ~ 9999 (ms)

0155	Maximum suppressed speed of single-step feed	1000
------	--	------

Setting range: 0 ~ 3000 (mm/min)

0156	S-type speed controlling time constant T1 in JOG feed of each axis	50
------	--	----

Setting range: 0 ~ 400 (ms)

0157	S-type speed controlling time constant T12 in JOG feed of each axis	40
------	---	----

Setting range: 0 ~ 400 (ms)

0158	Acceleration suppression constant in manual pulse incomplete running mode	50
------	---	----

Setting range: 0 ~ 1000 (ms)

0159	Magnification value in the 5 th gear of manual pulse feed (minimum setting unit: X setting)	1000
------	--	------

Setting range: 1 ~ 10000

0160	Command multiplication ratio (CMR) of the 1st axis	1
------	--	---

Setting range: 1 ~ 65536

0161	Command multiplication ratio (CMR) of the 2nd axis	1
------	--	---

Setting range: 1 ~ 65536

0162	Command multiplication ratio (CMR) of the 3rd axis	1
------	--	---

Setting range: 1 ~ 65536

0163	Command multiplication ratio (CMR) of the 4th axis	1
------	--	---

Setting range: 1 ~ 65536

0164	Command multiplication ratio (CMR) of the 5th axis	1
------	--	---

Setting range: 1 ~ 65536

0165	Command division ratio (CMD) of the 1st axis	1
------	--	---

Setting range: 1 ~ 65536

0166	Command division ratio (CMD) of the 2nd axis	1
------	--	---

Setting range: 1 ~ 65536

0167	Command division ratio (CMD) of the 3rd axis	1
------	--	---

Setting range: 1 ~ 65536

Appendix I List of Parameters

0168	Command division ratio (CMD) of the 4th axis	1
------	--	---

Setting range: 1 ~ 65536

0169	Command division ratio (CMD) of the 5th axis	1
------	--	---

Setting range: 1 ~ 65536

0170	Manual rapid positioning speed of the 1st axis	4000
------	--	------

Setting range: 0 ~ 30,000

0171	Manual rapid positioning speed of the 2nd axis	8000
------	--	------

Setting range: 0 ~ 30,000

0172	Manual rapid positioning speed of the 3rd axis	8000
------	--	------

Setting range: 0 ~ 30,000

0173	Manual rapid positioning speed of the 4th axis	8000
------	--	------

Setting range: 0 ~ 30,000

0174	Manual rapid positioning speed of the 5th axis	8000
------	--	------

Setting range: 0 ~ 30,000

0175	Program name on the 1st axis (0:X 1:Y 2:Z 3:A 4:B 5:C)	0
------	--	---

Setting range: 0 ~ 5

0176	Program name on the 2nd axis (0:X 1:Y 2:Z 3:A 4:B 5:C)	1
------	--	---

Setting range: 0 ~ 5

0177	Program name on the 3rd axis (0:X 1:Y 2:Z 3:A 4:B 5:C)	2
------	--	---

Setting range: 0 ~ 5

0178	Program name on the 4th axis (0:X 1:Y 2:Z 3:A 4:B 5:C)	4
------	--	---

Setting range: 0 ~ 5

0179	Program name on the 5th axis (0:X 1:Y 2:Z 3:A 4:B 5:C)	5
------	--	---

Setting range: 0 ~ 5

0180	Grating offset or reference point offset of the 1st axis	0
------	--	---

Setting range: -50 ~ 50

0181	Grating offset or reference point offset of the 2nd axis	0
------	--	---

Setting range: -50 ~ 50

0182	Grating offset or reference point offset of the 3rd axis	0
------	--	---

Setting range: -50 ~ 50

0183	Grating offset or reference point offset of the 4th axis	0
------	--	---

Setting range: -50 ~ 50

0184	Grating offset or reference point offset of the 5th axis	1
------	--	---

Setting range: -50 ~ 50

0189	Reverse determination accuracy of backlash compensation (X0.0001)	0.0100
------	---	--------

Setting range: 0.0001 ~ 1.0000 (mm)

Set $\alpha = p(189) \times 0.0001$. After feed is reversed, it is confirmed that backlash compensation starts if the servo periodic feed rate is greater than α .

Thus, during machining of large radius outer profile, it is required to set a small accuracy in order to ensure the compensation position does not deviate from the quadrant position. During machining of a curved surface, in order to prevent each tool path from conducting backlash compensation at a fixed point and forming an uplift, it is required to set a great accuracy so that backlash compensation is distributed within a certain width evenly.

0190	Backlash compensation amount of the 1st axis	0.0000
------	--	--------

Setting range:

- Metric: -0.5 ~ 0.5 (mm)
- British: -0.5 ~ 0.5/25.4 (inch)
- Rotating axis: -0.5 ~ 0.5000 (deg)

0191	Backlash compensation amount of the 2nd axis	0.0000
------	--	--------

Setting range:

- Metric: -0.5 ~ 0.5 (mm)
- British: -0.5 ~ 0.5/25.4 (inch)
- Rotating axis: -0.5 ~ 0.5 (deg)

0192	Backlash compensation amount of the 3rd axis	0.0000
------	--	--------

Setting range:

- Metric: -0.5 ~ 0.5 (mm)
- British: -0.5 ~ 0.5/25.4 (inch)
- Rotating axis: -0.5 ~ 0.5 (deg)

0193	Backlash compensation amount of the 4th axis	0.0000
------	--	--------

Setting range:

- Metric: -0.5 ~ 0.5 (mm)
- British: -0.5 ~ 0.5/25.4(inch)
- Rotating axis: -0.5 ~ 0.5(deg)

0194	Backlash compensation amount of the 5th axis	0.0000
------	--	--------

Setting range:

- Metric: -0.5 ~ 0.5(mm)
- British: -0.5 ~ 0.5/25.4(inch)
- Rotating axis: -0.5 ~ 0.5 (deg)

0195	Step length in fixed-frequency backlash compensation of the 1st axis	0.0030
------	--	--------

Setting range: 0 ~ 0.5 (mm)

0196	Step length in fixed-frequency backlash compensation of the 2nd axis	0.0030
------	--	--------

Setting range: 0 ~ 0.5 (mm)

0197	Step length in fixed-frequency backlash compensation of the 3rd axis	0.0030
------	--	--------

Setting range: 0 ~ 0.5 (mm)

0198	Step length in fixed-frequency backlash compensation of the 4th axis	0.0030
------	--	--------

Setting range: 0 ~ 0.5 (mm)

0199	Step length in fixed-frequency backlash compensation of the 5th axis	0.0030
------	--	--------

Setting range: 0 ~ 0.5 (mm)

0200	Time constant in variable-speed backlash compensation	20
------	---	----

Setting range: 0 ~ 400 (ms)

0203	Output time of reset signal	200
------	-----------------------------	-----

Setting range: 50 ~ 400 (ms)

0204	Allowable bits of M code	2
------	--------------------------	---

Setting range: 1 ~ 2

0205	Allowable bits of S code	5
------	--------------------------	---

Setting range: 1 ~ 6

0206	Allowable bits of T code	4
------	--------------------------	---

Setting range: 3 ~ 4

0207	Retardation time of strobe signal MF/SF/TF (n*8)	16
------	--	----

Setting range: 16 ~ 65535

0208	Acceptable width of M/S/T function ending signal (FIN) (n*8)	32
------	--	----

Setting range: 16 ~ 65535

0209	Compensation conditions for Z-axis friction compensation of machine tool (default: 1.0)	0
------	---	---

Setting range: 0 ~ 0

0210	Number increment in automatic insertion of sequence number	10
------	--	----

Setting range: 0 ~ 1000

0211	Opening number of tool bias that cannot be inputted in MDI	1
------	--	---

Setting range: 0 ~ 99

0212	Number of tool bias that cannot be inputted in MDI	99
------	--	----

Setting range: 0 ~ 99

0214	Arc radius error limit (mm)	0.05
------	-----------------------------	------

Setting range: 0.0001 ~ 0.1000 (mm)

0216	Pitch error compensation number of the 1st axis reference point	0
------	---	---

Setting range: 0 ~ 9999

0217	Pitch error compensation number of the 2nd axis reference point	0
------	---	---

Setting range: 0 ~ 9999

0218	Pitch error compensation number of the 3rd axis reference point	0
------	---	---

Setting range: 0 ~ 9999

0219	Pitch error compensation number of the 4th axis reference point	0
------	---	---

Setting range: 0 ~ 9999

0220	Pitch error compensation number of the 5th axis reference point	0
------	---	---

Setting range: 0 ~ 9999

0221	Pitch error compensation amount of the 1st axis moving from zeroing opposite to zero point	0
------	--	---

Setting range: -0.9999 ~ 0.9999

0222	Pitch error compensation amount on the 2nd axis moving from zeroing opposite to zero point	0
------	--	---

Setting range: -0.9999 ~ 0.9999

0223	Pitch error compensation amount of the 3rd axis moving from zeroing opposite to zero point	0
------	--	---

Setting range: -0.9999 ~ 0.9999

0224	Pitch error compensation amount of the 4th axis moving from zeroing opposite to zero point	0
------	--	---

Setting range: -0.9999 ~ 0.9999

0225	Pitch error compensation amount of the 5th axis moving from zeroing opposite to zero point	0
------	--	---

Setting range: -0.9999 ~ 0.9999

0226	Pitch error compensation space of the 1st axis	10
------	--	----

Setting range: 0 ~ 19999.9998

0227	Pitch error compensation space of the 2nd axis	5
------	--	---

Setting range: 0 ~ 9999.9999

Appendix I List of Parameters

0228	Pitch error compensation space of the 3rd axis	5
------	--	---

Setting range: 0 ~ 9999.9999

0229	Pitch error compensation space of the 4th axis	5
------	--	---

Setting range: 0 ~ 9999.9999

0230	Pitch error compensation space of the 5th axis	5
------	--	---

Setting range: 0 ~ 9999.9999

0231	Backlash compensation amount of the 1st axis in fast motion	0
------	---	---

Setting range: -0.5 ~ 0.5

0232	Backlash compensation amount of the 2nd axis in fast motion	0
------	---	---

Setting range: -0.5 ~ 0.5

0233	Backlash compensation amount of the 3rd axis in fast motion	0
------	---	---

Setting range: -0.5 ~ 0.5

0234	Backlash compensation amount of the 4th axis in fast motion	0
------	---	---

Setting range: -0.5 ~ 0.5

0235	Backlash compensation amount of the 5th axis in fast motion	0
------	---	---

Setting range: -0.5 ~ 0.5

0236	Rapid positioning accuracy of each axis (mm)	0.01
------	--	------

Setting range: 0.0001 ~ 0.5

0240	Gain adjustment data of spindle speed analog output	1
------	---	---

Setting range: 0.98 ~ 1.02

0241	Bias voltage compensation of spindle speed analog output	0
------	--	---

Setting range: -0.2 ~ 0.2

0242	Spindle speed in orientation or jogging	50
------	---	----

Setting range: 0 ~ 9999 (r/min)

0246	Maximum spindle speed corresponding to Gear 1	6000
------	---	------

Setting range: 0 ~ 99999 (r/min)

0247	Maximum spindle speed corresponding to Gear 2	6000
------	---	------

Setting range: 0 ~ 99999 (r/min)

0248	Maximum spindle speed corresponding to Gear 3	6000
------	---	------

Setting range: 0 ~ 99999 (r/min)

0250	Minimum suppressed speed of spindle motor	50
------	---	----

Setting range: 0 ~ 1000 (r/min)

0251	Maximum motor speed during spindle gear shift	6000
------	---	------

Setting range: 0 ~ 99999 (r/min)

0254	Counting datum axis in surface speed control	0
------	--	---

Setting range: 0 ~ 4

0255	Minimum spindle speed in constant surface speed control (G96)	100
------	---	-----

Setting range: 0 ~ 9999 (r/min)

0257	Upper limit of spindle speed in tapping cycle	6000
------	---	------

Setting range: 0 ~ 9999 (r/min)

0258	Upper limit of spindle speed	6000
------	------------------------------	------

Setting range: 0 ~ 99999 (r/min)

0261	Lines of spindle encoder	1024
------	--------------------------	------

Setting range: 0 ~ 9999

0262	Spindle motor speed at Gear 1-Gear 2 switching point	6000
------	--	------

Setting range: 0 ~ 9999 (r/min)

0263	Spindle motor speed at Gear 2-Gear 3 switching point	6000
------	--	------

Setting range: 0 ~ 9999 (r/min)

0264	Spindle motor speed at Gear 3-Gear 4 switching point	6000
------	--	------

Setting range: 0 ~ 9999 (r/min)

0266	Neglect the vector limit during movement along the corner outer in tool radius compensation C	0
------	---	---

Setting range: 0 ~ 9999.9999

0267	Positive and negative limits on each abrasion value inputted in tool offset	1
------	---	---

Setting range: 0 ~ 999.9999 (mm)

0268	Maximum error in tool radius compensation C	0.0010
------	---	--------

Setting range: 0.0001~0.0100

0270	G73 retracting amount of high-speed deep-hole cycle	2.0000
------	---	--------

Setting range: 0 ~ 999.9999 (mm)

0271	G83 blank space of fixed cycle	2.0000
------	--------------------------------	--------

Setting range: 0 ~ 999.9999 (mm)

0272	Pause time in returning to hole top	2
------	-------------------------------------	---

Setting range: 0 ~ 100 (ms)

0281	Shortest pause time at hole bottom	50
------	------------------------------------	----

Setting range: 0 ~ 1000 (ms)

Setting range: 1000 ~ 9999 (ms)

0283	Magnification in rigid tapping retracting	100
------	---	-----

Set

0282	Longest pause time at hole bottom	9999
------	-----------------------------------	------

Setting range: 0 ~ 100

Note: If Bit Para N0: 44#4=1, magnification is valid.

If N0:45#3=1, data unit is set to 10%; the maximum magnification set to 1000%.

0284	Retracting amount or blank space in deep-hole tapping cycle	2
------	---	---

Setting range: 0 ~ 100 (mm)

0286	Number of teeth of the spindle-side gear (the 1st gear)	1
------	---	---

Setting range: 1 ~ 999

0287	Number of teeth of the spindle-side gear (the 2nd gear)	1
------	---	---

Setting range: 1 ~ 999

0288	Number of teeth of the spindle-side gear (the 3rd gear)	1
------	---	---

Setting range: 1 ~ 999

0289	Number of teeth of the spindle-side gear (the 3rd gear)	1
------	---	---

Setting range: 1 ~ 999

0290	Number of teeth of the position encoder-side gear (the 1st gear)	1
------	--	---

Setting range: 1 ~ 999

0291	Number of teeth of the position encoder-side gear (the 2nd gear)	1
------	--	---

Setting range: 1 ~ 999

0292	Number of teeth of the position encoder-side gear (the 3rd gear)	1
------	--	---

Setting range: 1 ~ 999

0293	Number of teeth of the position encoder-side gear (the 4th gear)	1
------	--	---

Setting range: 1 ~ 999

0294	Maximum spindle speed in rigid tapping (the 1st gear)	6000
------	---	------

Setting range: 0 ~ 9999

0295	Maximum spindle speed in rigid tapping (the 2nd gear)	6000
------	---	------

Setting range: 0 ~ 9999

0296	Maximum spindle speed in rigid tapping (the 3rd gear)	6000
------	---	------

Setting range: 0 ~ 9999

0297	Maximum spindle speed in rigid tapping (the 4th gear)	6000
------	---	------

Setting range: 0 ~ 9999

0298	Linear speed controlling time constant for spindle and tapping axis (the 1st gear)	200
------	--	-----

Setting range: 0 ~ 9999

0299	Linear speed controlling time constant for spindle and tapping axis (the 2nd gear)	200
------	--	-----

Setting range: 0 ~ 9999

0300	Linear speed controlling time constant for spindle and tapping axis (the 3rd gear)	200
------	--	-----

Setting range: 0 ~ 9999

0301	Linear speed controlling time constant for spindle and tapping axis (the 4th gear)	200
------	--	-----

Setting range: 0 ~ 9999

0302	Time constant for spindle and tapping axis in tool retracting (the 1st gear)	200
------	--	-----

Setting range: 0 ~ 9999

0303	Time constant for spindle and tapping axis in tool retracting (the 2nd gear)	200
------	--	-----

Setting range: 0 ~ 9999

0304	Time constant for spindle and tapping axis in tool retracting (the 3rd gear)	200
------	--	-----

Setting range: 0 ~ 9999

0305	Time constant for spindle and tapping axis in tool retracting (the 4th gear)	200
------	--	-----

Setting range: 0 ~ 9999

0310	Rate of allowance for spindle regarded to reach the command speed (q)	5
------	---	---

Setting range: 0 ~ 1000

0311	Rate of change for spindle not giving a speed fluctuation detection alarm (r)	5
------	---	---

Setting range: 0 ~ 1000

Appendix I List of Parameters

0312	Fluctuation in spindle speed without giving a spindle speed fluctuation detection alarm (i)	10
------	---	----

Setting range: 0 ~ 9999

0313	Period from the change in command speed to the beginning of spindle speed fluctuation detection (p)ms	1000
------	---	------

Setting range: 0 ~ 99999

0320	Amount of clearance of rigid tapping spindle (the 1st gear)	0
------	---	---

Setting range: 0 ~ 99.9999

0321	Amount of clearance of rigid tapping spindle (the 2nd gear)	0
------	---	---

Setting range: 0 ~ 99.9999

0322	Amount of clearance of rigid tapping spindle (the 3rd gear)	0
------	---	---

Setting range: 0 ~ 99.9999

0323	Command multiplication ratio (CMR) of spindle (the 1st gear)	512
------	--	-----

Setting range: 0 ~ 9999

0324	Command multiplication ratio (CMR) of spindle (the 2nd gear)	512
------	--	-----

Setting range: 0 ~ 9999

0325	Command multiplication ratio (CMR) of spindle (the 3rd gear)	512
------	--	-----

Setting range: 0 ~ 9999

0326	Command division ratio (CMD) of spindle (the 1st gear)	25
------	--	----

Setting range: 0 ~ 9999

0327	Command division ratio (CMD) of spindle (the 2nd gear)	125
------	--	-----

Setting range: 0 ~ 9999

0328	Command division ratio (CMD) of spindle (the 3rd gear)	125
------	--	-----

Setting range: 0 ~ 9999

0340	Number of pre-processed blocks in decoding	0
------	--	---

Setting range: 0 ~ 0

0341	Buffer zone size at ARM interpolation point	36
------	---	----

Setting range: 0 ~ 99999

0342	Low-speed zeroing speed of the 1st axis	200
------	---	-----

Setting range: 0 ~ 1000

0343	Low-speed zeroing speed of the 2nd axis	200
------	---	-----

Setting range: 0 ~ 1000

0344	Low-speed zeroing speed of the 3rd axis	200
------	---	-----

Setting range: 0 ~ 1000

0345	Low-speed zeroing speed of the 4th axis	200
------	---	-----

Setting range: 0 ~ 1000

0346	Low-speed zeroing speed of the 5th axis	200
------	---	-----

Setting range: 0 ~ 1000

0352	Speed controlling time constant in high-speed zeroing	100
------	---	-----

Setting range: 3 ~ 400

0353	Speed controlling time constant in low-speed zeroing	30
------	--	----

Setting range: 3 ~ 100

0361	Speed controlling time constant 1 in thread cutting	20
------	---	----

Setting range: 1 ~ 200 (ms)

0362	Maximum acceleration of linear speed controlling in thread cutting (mm/s*s)	5000
------	---	------

Setting range: 1 ~ 10000(ms)

0365	Stub-axle speed controlling time constant in thread tail rolling	10
------	--	----

Setting range: 1 ~ 200(ms)

0366	Pulse sampling period of spindle in thread cutting (ms)	16
------	---	----

Setting range: 0 ~ 32

0367	Linear speed controlling time constant in rigid thread cutting	40
------	--	----

Setting range: 1 ~ 400

0368	Initial speed in thread cutting	0
------	---------------------------------	---

Setting range: 1 ~ 8000

0370	Interval for thread block ending (ms)	0
------	---------------------------------------	---

Setting range: 0 ~ 9

0371	Reverse positioning tolerance of the 1st axis	0.0150
------	---	--------

Setting range: 0 ~ 99.9999 (mm)

0372	Reverse positioning tolerance of the 2nd axis	0.0150
------	---	--------

Setting range: 0 ~ 99.9999 (mm)

Appendix I List of Parameters

0373	Reverse positioning tolerance of the 3rd axis	0.0150
------	---	--------

Setting range: 0 ~ 99.9999 (mm)

0374	Reverse positioning tolerance of the 4th axis	0.0150
------	---	--------

Setting range: 0 ~ 99.9999 (mm)

0375	Reverse positioning tolerance of the 5th axis	0.0150
------	---	--------

Setting range: 0 ~ 99.9999 (mm)

If the backlash compensation setting (P0190---P0193) of some axis is greater than its reverse positioning tolerance setting (P0371---P0374), the spot speed at one section terminal before backlash compensation decreases to the minimum speed so that other axes move a short distance during the period of backlash compensation and the synthetic track deviates little from the actual track.

0376	Sequence of axis movement to program restart position	12345
------	---	-------

Setting range: 0 ~ 99999

0380	Setting of the axis synchronized with the 4th axis 0: not synchronized with any axis; 1: X-axis; 2: Y-axis; 3: Z-axis	0
------	---	---

Setting range: 0 ~ 3

0381	Maximum permissible error between synchronous axes	200
------	--	-----

Setting range: 0 ~ 10000

0382	Set the dual-drive reference position difference	0.0000
------	--	--------

Setting range: 0.0000 ~ 2000.0000

0384	Control axis number of tool rotating axis for polygon machining	1500
------	---	------

Setting range: 0 ~ 2500

0385	Maximum speed of tool rotating axis for polygon machining	0
------	---	---

Setting range: 0 ~ 5

0386	Spindle speed variation permission level in polygon machining between spindles	0
------	--	---

Setting range: 0 ~ 0

0387	Steady-state confirmation state in polygon machining between spindles	0
------	---	---

Setting range: 0 ~ 0

0388	Master axis in polygon machining between spindles	0
------	---	---

Setting range: 0 ~ 0

0389	Polygonal synchronized axis in polygon machining between spindles	0
------	---	---

Setting range: 0 ~ 0

0392	Moving distance in servo optimization	50
------	---------------------------------------	----

Setting range: 0 ~ 100

0393	Movement speed in servo optimization	2000
------	--------------------------------------	------

Setting range: 0 ~ 5000

0394	The 1st axis backup of coordinate system	0
------	--	---

Setting range: -9999.9999 ~ 9999.9999

0395	The 2nd axis backup of coordinate system	0
------	--	---

Setting range: -9999.9999 ~ 9999.9999

0396	The 3rd axis backup of coordinate system	0
------	--	---

Setting range: -9999.9999 ~ 9999.9999

0397	The 4th axis backup of coordinate system	0
------	--	---

Setting range: -9999.9999 ~ 9999.9999

0398	The 5th axis backup of coordinate system	0
------	--	---

Setting range: -9999.9999 ~ 9999.9999

400	Gain adjustment data of the 2 nd spindle speed analog output	1
-----	---	---

Setting range: 0.98 ~ 1.02

401	Bias voltage compensation value in the 2nd spindle speed analog output	0
-----	--	---

Setting range: -0.2 ~ 0.2

402	Spindle speed in the 2nd spindle orientation or gear shift	50
-----	--	----

Setting range: 0 ~ 9999

403	Maximum spindle speed corresponding to Tooth 2	6000
-----	--	------

Setting range: 0 ~ 9999

404	Maximum spindle speed corresponding to Tooth 2	6000
-----	--	------

Setting range: 0 ~ 9999

405	Maximum spindle speed corresponding to Tooth 2	6000
-----	--	------

Setting range: 0 ~ 9999

406	Maximum spindle speed corresponding to Tooth 2	6000
-----	--	------

Setting range: 0 ~ 9999

407	Minimum suppression speed of the 2nd spindle motor	50
-----	--	----

Setting range: -0.2 ~ 0.2

Appendix I List of Parameters

408	Maximum suppression speed of the 2nd spindle motor	6000
-----	--	------

Setting range: - 0.2 ~ 0.2

409	Maximum speed of the 2nd spindle	6000
-----	----------------------------------	------

Setting range: 0 ~ 99999

410	Number of lines of the 2nd spindle encoder	1024
-----	--	------

Setting range: 1 ~ 999

411	Number of teeth of the 2nd spindle-side gear (the 1st gear)	1
-----	---	---

Setting range: 1 ~ 999

412	Number of teeth of the 2nd spindle-side gear (the 2nd gear)	1
-----	---	---

Setting range: 1 ~ 999

413	Number of teeth of the 2nd spindle-side gear (the 3rd gear)	1
-----	---	---

Setting range: 1 ~ 999

414	Number of teeth of the 2nd spindle-side gear (the 4th gear)	1
-----	---	---

Setting range: 1 ~ 999

415	Number of teeth of the 2nd spindle encoder-side gear (the 1st gear)	1
-----	---	---

Setting range: 1 ~ 999

416	Number of teeth of the 2nd spindle encoder-side gear (the 2nd gear)	1
-----	---	---

Setting range: 1 ~ 999

417	Number of teeth of the 2nd spindle encoder-side gear (the 3rd gear)	1
-----	---	---

Setting range: 1 ~ 999

418	Number of teeth of the 2nd spindle encoder-side gear (the 4th gear)	1
-----	---	---

Setting range: 1 ~ 999

419	Spindle motor speed at the 2nd spindle Gear 1-Gear 2 switching point	6000
-----	--	------

Setting range: 0 ~ 99999 (r/min)

420	Spindle motor speed at the the 2nd spindle Gear 2-Gear 3 switching point	6000
-----	--	------

Setting range: 0 ~ 99999 (r/min)

421	Spindle motor speed at the 2nd spindle Gear 3-Gear 4 switching point	6000
-----	--	------

Setting range: 0 ~ 99999 (r/min)

422	Forward-rotation M code of the 2nd spindle	63
-----	--	----

Setting range: 0 ~ 99

423	Reverse-rotation M code of the 2nd spindle	64
-----	--	----

Setting range: 0 ~ 99

424	Servo axis number in position output of the 2nd spindle speed command pulse string (0: invalid; 1~5: the 1st axis ~the 5th axis)	0
-----	--	---

Setting range: 0 ~ 5

425	Linear speed controlling time constant for the 2nd spindle and tapping axis (the 1st gear)	200
-----	--	-----

Setting range: 0 ~ 9999

426	Linear speed controlling time constant for the 2nd spindle and tapping axis (the 2nd gear)	200
-----	--	-----

Setting range: 0 ~ 9999

427	Linear speed controlling time constant for the 2nd spindle and tapping axis (the 3rd gear)	200
-----	--	-----

Setting range: 0 ~ 9999

428	Linear speed controlling time constant for the 2nd spindle and tapping axis (the 4th gear)	200
-----	--	-----

Setting range: 0 ~ 9999

429	Time constant for the 2nd spindle and tapping axis in tool retracting (the 1st gear)	200
-----	--	-----

Setting range: 0 ~ 9999

430	Time constant for the 2nd spindle and tapping axis in tool retracting (the 2nd gear)	200
-----	--	-----

Setting range: 0 ~ 9999

431	Time constant for the 2nd spindle and tapping axis in tool retracting (the 3rd gear)	200
-----	--	-----

Setting range: 0 ~ 9999

432	Time constant for the 2nd spindle and tapping axis in tool retracting (the 4th gear)	200
-----	--	-----

Setting range: 0 ~ 9999

433	Amount of clearance of the 2nd spindle in rigid tapping (the 1st gear)	0
-----	--	---

Setting range: 0 ~ 99.9999

434	Amount of clearance of the 2nd spindle in rigid tapping (the 2nd gear)	0
-----	--	---

Setting range: 0 ~ 99.9999

Appendix I List of Parameters

435	Amount of clearance of the 2nd spindle in rigid tapping (the 3rd gear)	0
-----	--	---

Setting range: 0 ~ 99.9999

4440	M code started in Cs contouring control axis function	14
------	---	----

Setting range: 0 ~ 9999

4441	M code closed in Cs contouring control axis function	15
------	--	----

Setting range: 0 ~ 9999

0445	Configuration grating accuracy of Axis 1	0.001
------	--	-------

Setting range: 0.0000 ~ 10.0000

0446	Configuration grating accuracy of Axis 2	0.001
------	--	-------

Setting range: 0.0000 ~ 10.0000

0447	Configuration grating accuracy of Axis 3	0.001
------	--	-------

Setting range: 0.0000 ~ 10.0000

0448	Configuration grating accuracy of Axis 4	0.001
------	--	-------

Setting range: 0.0000 ~ 10.0000

0449	Configuration grating accuracy of Axis 5	0.001
------	--	-------

Setting range: 0.0000 ~ 10.0000

0450	Position deviation limit (mm) in the 1st axis movement	10
------	--	----

Setting range: 0.0000 ~ 99.9999

0451	Position deviation limit (mm) in the 2nd axis movement	10
------	--	----

Setting range: 0.0000 ~ 99.9999

0452	Position deviation limit (mm) in the 3rd axis movement	10
------	--	----

Setting range: 0.0000 ~ 99.9999

0453	Position deviation limit (mm) in the 4th axis movement	10
------	--	----

Setting range: 0.0000 ~ 99.9999

0454	Position deviation limit (mm) in the 5th axis movement	10
------	--	----

Setting range: 0.0000 ~ 99.9999

0455	Position deviation limit (mm) when the 1st axis stops	0.5
------	---	-----

Setting range: 0.0000 ~ 9.9999

0456	Position deviation limit (mm) when the 2nd axis stops	0.5
------	---	-----

Setting range: 0.0000 ~ 9.9999

0457	Position deviation limit (mm) when the 3rd axis stops	0.5
------	---	-----

Setting range: 0.0000 ~ 9.9999

0458	Position deviation limit (mm) when the 4th axis stops	0.5
------	---	-----

Setting range: 0.0000 ~ 9.9999

0459	Position deviation limit (mm) when the 5th axis stops	0.5
------	---	-----

Setting range: 0.0000 ~ 9.9999

0460	Non-monotonic allowed value of composite machining cycles G71 and G72 (Z-axis)	0.1
------	--	-----

Setting range: 0.0000 ~ 9999.9999

0461	Non-monotonic allowed value of composite machining cycles G71 and G72 (X-axis)	0.1
------	--	-----

Setting range: 0.0000 ~ 9999.9999

0462	Retracting amount of composite machining fixed cycles G71 and G72	0
------	---	---

Setting range: -9999.0000 ~ 9999.9999

0463	Retracting amount of composite machining fixed cycles G71 and G72	0
------	---	---

Setting range: -9999.0000 ~ 9999.9999

0465	Retracting distance of composite machining fixed cycle G 73 (X-axis)	0
------	--	---

Setting range: -9999.0000 ~ 9999.9999

0466	Retracting distance of composite machining fixed cycle G 73 (Z-axis)	0
------	--	---

Setting range: -9999.0000 ~ 9999.9999

0467	Partition times of composite machining fixed cycle G73	0
------	--	---

Setting range: -9999 ~ 9999

0468	Retracting amount of composite machining fixed cycles G74 and G75	0
------	---	---

Setting range: -9999.0000 ~ 9999.9999

0469	Minimum feeding amount of composite machining fixed cycle G76	0
------	---	---

Setting range: -9999.0000 ~ 9999.9999

0470	Fine machining allowance of composite machining fixed cycle G76	0
------	---	---

Setting range: -9999.0000 ~ 9999.9999

0471	Number of fine machining allowance repetitions of composite machining fixed cycle G76	0
------	---	---

Setting range: -9999 ~ 9999

Appendix I List of Parameters

0472	Tool nose angle of composite machining fixed cycle G76	0
------	--	---

Setting range: 9999 ~ 9999

0473	Chamfer of threading cycle (G92,G76) (setting *0.1 lead distance)	0
------	---	---

Setting range: 0 ~ 127

0474	Cutting angle of threading cycle G76	0
------	--------------------------------------	---

Setting range: 0 ~ 89

0475	Whether composite machining fixed cycles G71 and G72 execute the final rough turning trajectory	0
------	---	---

Setting range: 0 ~ 1

0476	Idle stroke at the start position of composite machining fixed cycle G71 cutting feed	1
------	---	---

Setting range: 0 ~ 5

0477	Whether the groove tool retracting of composite machining fixed cycle G71 uses 45° retracting	0
------	---	---

Setting range: 0 ~ 1

0480	Control axis executing the function of the 1 st position switch	0
------	--	---

Setting range: 0 ~ 5

0481	Control axis executing the function of the 2 nd position switch	0
------	--	---

Setting range: 0 ~ 5

0482	Control axis executing the function of the 3 rd position switch	0
------	--	---

Setting range: 0 ~ 5

0483	Control axis executing the function of the 4 th position switch	0
------	--	---

Setting range: 0 ~ 5

0484	Control axis executing the function of the 5 th position switch	0
------	--	---

Setting range: 0 ~ 5

0485	Control axis executing the function of the 6 th position switch	0.
------	--	----

Setting range: 0 ~ 5

0486	Control axis executing the function of the 7 th position switch	0
------	--	---

Setting range: 0. ~ 5

0487	Control axis executing the function of the 8 th position switch	0
------	--	---

Setting range: 0 ~ 5

0488	Control axis executing the function of the 9 th position switch	0
------	--	---

Setting range: 0 ~ 5

0489	Control axis executing the function of the 10 th position switch	0
------	---	---

Setting range: 0 ~ 5

0490	Maximum in the action range of the 1 st position switch	0.0000
------	--	--------

Setting range: -9999.9999 ~ 9999.9999

0491	Maximum in the action range of the 2 nd position switch	0.0000
------	--	--------

Setting range: -9999.9999 ~ 9999.9999

0492	Maximum in the action range of the 3 rd position switch	0.0000
------	--	--------

Setting range: -9999.9999 ~ 9999.9999

0493	Maximum in the action range of the 4 th position switch	0.0000
------	--	--------

Setting range: -9999.9999 ~ 9999.9999

0494	Maximum in the action range of the 5 th position switch	0.0000
------	--	--------

Setting range: -9999.9999 ~ 9999.9999

0495	Maximum in the action range of the 6 th position switch	0.0000
------	--	--------

Setting range: -9999.9999 ~ 9999.9999

0496	Maximum in the action range of the 7 th position switch	0.0000
------	--	--------

Setting range: -9999.9999 ~ 9999.9999

0497	Maximum in the action range of the 8 th position switch	0.0000
------	--	--------

Setting range: -9999.9999 ~ 9999.9999

0498	Maximum in the action range of the 9 th position switch	0.0000
------	--	--------

Setting range: -9999.9999 ~ 9999.9999

0499	Maximum in the action range of the 10 th position switch	0.0000
------	---	--------

Setting range: -9999.9999 ~ 9999.9999

0500	Minimum in the action range of the 1 st position switch	0.0000
------	--	--------

Setting range: -9999.9999 ~ 9999.9999

0501	Minimum in the action range of the 2 nd position switch	0.0000
------	--	--------

Setting range: -9999.9999 ~ 9999.9999

0502	Minimum in the action range of the 3 rd position switch	0.0000
------	--	--------

Setting range: -9999.9999 ~ 9999.9999

Appendix I List of Parameters

0503	Minimum in the action range of the 4 th position switch	0.0000
------	--	--------

Setting range: -9999.9999 ~ 9999.9999

0504	Minimum in the action range of the 5 th position switch	0.0000
------	--	--------

Setting range: -9999.9999 ~ 9999.9999

0505	Minimum in the action range of the 6 th position switch	0.0000
------	--	--------

Setting range: -9999.9999 ~ 9999.9999

0506	Minimum in the action range of the 7 th position switch	0.0000
------	--	--------

Setting range: -9999.9999 ~ 9999.9999

0507	Minimum in the action range of the 8 th position switch	0.0000
------	--	--------

Setting range: -9999.9999 ~ 9999.9999

0508	Minimum in the action range of the 9 th position switch	0.0000
------	--	--------

Setting range: -9999.9999 ~ 9999.9999

0509	Minimum in the action range of the 10 th position switch	0.0000
------	---	--------

Setting range: -9999.9999 ~ 9999.9999

0530	Linear axis number in polar coordinate interpolation (0: None 1~5: the 1st axis ~the 5th axis)	0.0000
------	---	--------

Setting range: 0 ~ 5

0531	Rotating axis number in polar coordinate interpolation (0: None 1~5: the 1st axis ~the 5th axis)	0.0000
------	---	--------

Setting range: 0 ~ 5

0532	Automatic rate and allowance rate in polar coordinate interpolation, in % (0~100)	90
------	---	----

Setting range: 0 ~ 100

0533	Compensation for hypothetical axis direction error in polar coordinate interpolation	0.0000
------	--	--------

Setting range: -999.0000 ~ 999.0000

0535	Set the 1st axis as the axis in basic coordinate system	1
------	---	---

Setting range: 0 ~ 7

0536	Set the 2nd axis as the axis in basic coordinate system	2
------	---	---

Setting range: 0 ~ 7

0537	Set the 3rd axis as the axis in basic coordinate system	3
------	---	---

Setting range: 0 ~ 7

0538	Set the 4th axis as the axis in basic coordinate system	0
------	---	---

Setting range: 0 ~ 7

0539	Set the 5th axis as the axis in basic coordinate system	0
------	---	---

Setting range: 0 ~ 7

0540	System axis number under PMC-axis control (0: None 1~5: the 1st axis ~ the 5th axis)	0
------	--	---

Setting range: 0 ~ 5

0541	Least unit of PMC-axis control data (0.0001~360.0)	0.0010
------	--	--------

Setting range: 0.0001 ~ 360.0000

0542	Speed controlling time in speed command under PMC-axis control	500
------	--	-----

Setting range: 10 ~ 99999

0545	System axis number under the 2 nd PMC-axis control (0: None 1~5: the 1st axis ~the 2nd axis)	0
------	---	---

Setting range: 0 ~ 5

0546	Least unit of the 2 nd PMC-axis control data (0.0001~360.0)	0.001
------	--	-------

Setting range: 0.0001 ~ 360

0547	Speed controlling time in speed command under the 2 nd PMC-axis control	500
------	--	-----

Setting range: 10 ~ 99999

0550	System axis number under the 3 rd PMC-axis control (0: None 1~5: the 1st axis ~the 2nd axis)	0
------	---	---

Setting range: 0 ~ 5

0551	Least unit of the 3 rd PMC-axis control data (0.0001~360.0)	0.001
------	--	-------

Setting range: 0.0001 ~ 360

0552	Speed controlling time in speed command under the 3 rd PMC-axis control	500
------	--	-----

Setting range: 10 ~ 99999

0555	System axis number under the 4 th PMC-axis control (0: None 1~5: the 1st axis ~the 2nd axis)	0
------	---	---

Setting range: 10 ~ 9999

0556	Speed controlling time in speed command under the 4 th PMC-axis control (0.0001~360.0)	0.001
------	---	-------

Setting range: 0.0001 ~ 360

0557	Speed controlling time in speed command under the 4 th PMC-axis control	500
------	--	-----

Setting range: 10 ~ 9999

Appendix II Alarm Table

Alarm No.	Alarm Content	Remarks
0000	This parameter modification requires one-time power-off.	
0001	File opening failed	
0002	Input data out of range	
0003	Program number exists	
0004	Digit or Character "-" inputted at the beginning of block should not exist. Modify program.	
0005	The address is followed by another address or EOB code instead of proper data. Modify program.	
0006	Character "-" input error (Character "-" or two or more "-" are inputted behind an address that cannot have a minus sign). Modify program.	
0007	Decimal point "." input error (Character "." or two or more "." are inputted in an address that cannot have a decimal point). Modify program.	
0008	Program file is too large.	
0009	The address inputted is illegal. Modify program.	
0010	The G code used is not available or the G code commanded does not have this function. Modify program.	
0011	The feed speed is not commanded or is improper in cutting feed. Modify program.	
0012	Out of disk space. Fail to create a file or add to the file.	
0013	The number of program files has reached its upper limit. Fail to create a program.	
0015	Allowed simultaneously controlled axes exceeded	
0016	Current pitch error compensation point out of range	
0017	Modification permission denied. Please input a password on password interface.	
0018	Neither null variable or local variable can be modified. G10 can only modify the user-level parameters.	
0020	In arc interpolation (G02 or G03), the distance from start point to arc center is different from that from end point. Their difference exceeds the value specified in number parameter 214.	
0021	In arc interpolation, an axis commanded is not available on the selected plane (G17,G18,G19). Modify program.	
0022	In arc interpolation, neither R(specified arc radius) nor I, J, K (specified distance from start point to center) is commanded.	
0023	In arc interpolation, both IJK and R are specified.	
0026	File format unsupported. The file is big or includes a line exceeding 1024 bytes.	
0028	In planar selective command, two or more axes are commanded in the same direction. Modify program.	
0031	The command P value is too large or unspecified in the setting of offset value, workpiece coordinate system, external workpiece coordinate system, or additional workpiece coordinate system through G10.	
0032	The offset value is too large or unspecified in its setting through G10 or in its writing through system variable. Modify program.	
0033	The intersection in tool offset C or chamfer is not sure. Modify program.	

Alarm No.	Alarm Content	Remarks
0034	Fail to create or cancel the tool offset in the case of arc instruction. Modify program.	
0036	In tool offset mode, jump cutting is commanded (G31). Modify program.	
0037	The plane selected through G17, G18, or G19 is changed in tool offset C. Modify program.	
0038	In tool offset C, over-cutting will occur, because the start point or end point of arc coincides with arc center. Modify program.	
0039	Tool nose positioning error in tool offset C	
0040	Fail to switch the workpiece coordinate system in tool offset C. Please cancel the tool offset before coordinate system switching.	
0041	Interference exists in tool offset C, and over-cutting will occur. Modify program.	
0042	More than ten blocks specifying parking instruction instead of moving instruction are continuously commanded in tool offset mode. Modify program.	
0043	Permission denied. Please modify the permission on password interface.	
0044	In fixed cycle mode, one of G27, G28, G29, and G30 is commanded. Modify program.	
0045	In fixed cycle G73/G83, the cutting depth (Q) is unspecified or equal to 0. Modify program.	
0046	In the 2 nd , 3 rd , 4 th reference points returning command, a command other than P2, P3, and P4 is given.	
0050	Change the moving position in fixed cycle mode.	
0051	The block behind fillet or chamfer specifies a wrong movement or moving distance. Modify program.	
0053	Chamfer or fillet command format error. Modify program.	
0055	Chamfer movement failed	
0056	M99 cannot stay in the same block with macro-program command (G65). Modify program.	
0057	File writing failed. Please de-energize the system before restart.	
0058	In any chamfer or fillet block, the specified axis is not on the selected plane. Modify program.	
0059	In external program number retrieving, program number is not found or the specified program is edited in the background. Please check the program number and external signal or suspend background editing.	
0060	Sequence number is not found in sequence number searching. Please check the sequence number.	
0061	The 1st axis away from reference point	
0062	The 2nd axis away from reference point	
0063	The 3rd axis away from reference point	
0064	The 4th axis away from reference point	
0065	The 5th axis away from reference point	
0066	Cancel the fixed cycle mode before execution of parameter input (G10)	
0067	Setting format unsupported by G10	
0068	Parameter switch is not on	
0069	Close U disk operation interface before machining	
0070	Out of memory. Please delete unnecessary programs before retrying.	

Appendix II Alarm Table

Alarm No.	Alarm Content	Remarks
0071	Target address is not found, or the specified program not found in program retrieving. Please check the data.	
0072	Over 400 programs are stored. Delete unwanted programs.	
0073	The commanded program number has been occupied. Change the program number or delete unwanted programs.	
0074	Program number beyond 1–99999. Change the program number.	
0075	Attempting to register a protected program number.	
0076	Address P(program number) is not specified in M98 block. Modify program.	
0077	Program calling exceeds 5 times. Modify program.	
0078	In M98 or G65 block, the program number specified by address P is not found or the macro-program called by M06 does not exist.	
0079	System service life expires. Please contact the supplier.	
0080	Input data are unreasonable. Maximum speed is lower than minimum speed or minimum speed is higher than maximum speed	
0081	Macro-program cannot call the subprogram. Modify program.	
0084	Key overtime or short-circuit occurs.	
0085	Effluence occurs when data are inputted via serial port. The baud rate setting or input/output device is incorrect.	
0086	In fixed cycle mode, system cannot switch planes.	
0087	NO.0087~0091 alarm mean that reference point returning is unavailable because the start point of each axis is too close to the reference point or because the speed is too low. Keep reference point far enough from start point or set a high speed of returning.	
0092	G27 (reference point returning checking) instructed not to return to reference point	
0093	Motor model mismatching	
0098	After power-one, after emergency stop, or if program including G28 does not return to reference point, execute the program before restart.	
0100	In parameter (setting) screen, PWE (parameter writing effective) is set to 1. Please set it to 0 before restarting the system.	
0101	Power-cut memory data disorder. Please ensure the position is correct.	
0102	The motor model of system disagrees with that of drive.	
0103	bus communication error. Please check the cable reliability.	
0104	Machine zero setting overtime	
0105	drive unit data acquisition overtime	
0106	Gear ratio of drive unit disagrees with that of system servo parameters	
0107	Parameters of drive unit disagree with that of system servo parameters	
0108	Please insert U disk.	
0110	Position data beyond allowed range. Please clear the data.	
0111	Calculation result beyond allowed range ($-10^{47} \sim -10^{-29}$, 0 and $10^{-29} \sim 10^{47}$)	
0112	Zero (including $\tan 90^\circ$) divisor specified	
0113	User macro-program specifies an unavailable function command. Modify program.	
0114	G39 format error. Modify program.	

Alarm No.	Alarm Content	Remarks
0115	Fail to specify the variable value or to use O, N as variable specified in user macro-program. Modify program.	
0116	A variable is on the left of assignment statement but cannot be assigned. Modify program.	
0117	This parameter does not support G10 online modification. Please modify the program.	
0118	Parenthesis nesting exceeds its upper limit (five layers). Modify program.	
0119	M00, M01, M02, M30, M98, M99, M06 commands cannot stay in the same block with other M commands.	
0120	Part settings are restored.	
0121	machine coordinate and encoder feedback exceed the deviation setting.	
0122	Nesting layers called by macro-program exceed 5. Modify program.	
0124	Program ends illegally, without a M30/M02/M99 command or a ending character. Modify program.	
0125	Macro-program format error. Modify program.	
0126	Program cycle false. Modify program.	
0127	NC and user macro command statements co-exist. Modify program.	
0128	Sequence number is not 0-99999, or is not found, in branch command. Modify program.	
0129	<independent variable assignment> address false. Modify program.	
0130	PLC-axis control command is outputted to a CNC controlled axis; or CNC-axis control command is outputted to PLC controlled axis. Modify program.	
0131	5 or more external alarm messages occurring. Check the ladder graph.	
0132	The alarm of external alarm message does not exist. Check PLC.	
0133	Axis command unsupported. Modify program.	
0135	The indexing angle of index workbench is not a multiple of angle unit. Modify program.	
0136	Index workbench indexing specifies B axis and another axis. Modify program.	
0137	The sequence number to be transferred according to jump instruction is inside loop cycle. Modify program.	
0138	Loop statement mismatching or jump instruction entering loop cycle. Modify program.	
0139	Selected axis error under PLC-axis control. Modify program.	
0140	Sequence number specified in macro command does not exit.	
0142	Scaling magnification beyond 1-999999 specified. Modify the scaling setting.	
0145	G28 command specified before reference point is determined.	
0148	automatic corner deceleration beyond judgment corner setting range. Modify the parameter.	
0150	Wrong modal command	
0151	An unavailable command is specified between blocks specified by P and Q in composite fixed cycle.	
0160	In polar coordinate mode, arc can only be programmed by R.	
0161	In polar coordinate mode, a reference point, or plane selection, or direction related command cannot be executed.	

Appendix II Alarm Table

Alarm No.	Alarm Content	Remarks
0165	Please specify a command, scaling or G10 command, in a single block.	
0166	No axis specified during reference point returning	
0167	Midpoint coordinate is too large.	
0168	Hole-bottom minimum pause time should be shorter than hole-bottom maximum pause time.	
0170	Tool radius compensation is not canceled when entering or exiting subprogram.	
0172	In the block calling the subprogram, P is not an integer or P is smaller than or equal to 0.	
0173	Subprogram calling times cannot exceed 9999.	
0175	Fixed cycle can only be executed on G17 plane.	
0176	Spindle speed unspecified before the start of rigid tapping	
0177	IO control under G76 command does not support the spindle orientation function. Modify the program or parameter	
0178	Spindle speed unspecified before the start of fixed cycle	
0181	Illegal M code	
0182	Spindle speed is too high or too low.	
0183	Illegal T code	
0184	Selected tool out of range	
0189	U is too small. U should be greater than or equal to tool radius.	
0190	V is too small or V is undefined. V should be greater than 0.	
0191	W is too small or W is undefined. W should be greater than 0.	
0192	Q is too small or Q is undefined. Q should be greater than 0.	
0193	I is undefined or I is 0.	
0194	J is undefined or J is 0.	
0195	D is undefined or D is 0.	
0198	In constant surface cutting speed control, the specified axis is wrong. (See parameter No.254). Its command P includes illegal data. Modify program.	
0199	Macro command undefined. Modify program.	
0200	In rigid tapping, S value is out of range or unspecified. In rigid tapping, S_{max} is specified through a parameter. Modify the parameter setting or program.	
0204	M29 should be specified in G80 mode. Modify program.	
0206	Plane switching is specified in rigid mode. Modify program.	
0208	This command cannot be executed in G10 mode. Please cancel G10 mode first.	
0210	Program restart filename is inconsistent. Please select correct filename.	
0212	The chamfer or reverse R is commanded or there is an additional axis on the plane. Modify program.	
0213	Tool shift macro-program does not support G31 jump. Modify program.	
0214	Tool shift macro-program does not support jump operation.	
0215	Tool shift macro-program does not support dynamic modification of coordinate system and tool offset.	
0219	Tool base is unused (parameter is not opened). Cannot use tool shift	

Alarm No.	Alarm Content	Remarks
	command M06.	
0220	Scaling/rotation/polar coordinate does not support metric-British input switching.	
0221	Tool shift macro-program does not support metric-British input switching.	
0224	Before the start of automatic running, reference point returning is not executed.	
0231	In the specified format of program parameter input, the following errors occur: 1) Address N or R is not inputted; 2) Parameter No. is unspecified; 3) Address P is unspecified when bit parameter is inputted to L50; 4) N, P, R are out of range. Modify program.	
0232	3 or more axes are specified as spiral interpolation axes.	
0233	Other operations are using the device connecting to the RS-232-C port.	
0235	Record ending character (%) is commanded.	
0236	Program restart parameter setting error	
0237	The decimal point of command is unspecified as necessary.	
0238	The same address occurs many times in a block, or two or more G codes of the same group occur in a block.	
0239	An illegal G code is specified in pre-reading control mode. The indexing axis is specified in pre-processing control mode. Maximum cutting feed parameter is set to 0. Speed controlling parameter before interpolation is set to 0. Set parameters properly.	
0241	Manual pulse exception	
0242	Bus connection error	
0250	Axis name already exists. Please modify the parameters NO.175~179.	
0251	emergency stop alarm. After canceling the alarm, please return to zero point again.	
0252	Program ending illegal (CNC transmission speed is low. Please decrease the feed speed)	
0261	The pulse command speed of DSP interpolation axis is too high. Please press "reset" before zero-point returning.	
0262	DSP alarm: DSP is not started. Please energize the system again.	
0263	DSP alarm: DSP parameter setting error	
0264	DSP alarm: The sent data is too large. Please energize the system again.	
0265	DSP alarm: Bus cannot be connected, or bus initialization fails.	
0266	DSP interpolation axis speed exceeds 200M/MIN. Please press "reset" before zero-point returning.	
0267	DSP initialization mark (5555) exception. Please press "reset" before zero-point returning.	
0268	The unit cycle output of DSP is too large. Please press "reset" before zero-point returning.	
0269	DSP internal alarm. Please press "reset" before zero-point returning.	
0270	The interpolation point length divided equally by DSP is too small.	
0271	Interpolation data received by DSP are too small. Press "emergency stop" before zero returning again.	
0272	DSP receives an unidentifiable G code.	

Appendix II Alarm Table

Alarm No.	Alarm Content	Remarks
0273	DSP hardware data interaction exception (command type)	
0274	DSP hardware data interaction exception (data type)	
0275	In high-speed mode, interpolation speed magnification is 0.	
0280	Before the use of tool setting function, each axis should return to zero point first.	
0281	It is required to switch to [setting][tool setting center division] interface before the use of tool setting function.	
0282	Please check whether the tool setting meter is installed or whether bit parameter 1.6 is set to 1.	
0283	Z-axis surpasses the safe position. Please check tool setting meter or tool length setting.	
0286	Automatic measurement error. Please execute measurement once again.	
0401	Drive unit alarm 01: Servo motor speed exceeds its setting	
0402	Drive unit alarm 02: Primary circuit supply voltage is too high.	
0403	Drive unit alarm 03: Primary circuit supply voltage is too low.	
0404	Drive unit alarm 04: The value of position deviation counter exceeds the setting.	
0405	Drive unit alarm 05: motor overheating	
0406	Drive unit alarm 06: Speed controller is saturated for long.	
0407	Drive unit alarm 07: Both CCW and CW drive inputs are off.	
0408	Drive unit alarm 08: The absolute value of position deviation counter reading exceeds 230.	
0409	Drive unit alarm 09: Encoder signal error	
0410	Drive unit alarm 10: Control supply $\pm 15V$ is low	
0411	Drive unit alarm 11: IPM intelligent module fault	
0412	Drive unit alarm 12: Motor current is too large.	
0413	Drive unit alarm 13: servo drive unit and motor overload (instantaneous overheating)	
0414	Drive unit alarm 14: braking circuit fault	
0415	Drive unit alarm 15: encoder counting exception	
0420	Drive unit alarm 20: EEPROM error	
0430	Drive unit alarm 30: encoder Z pulse error	
0431	Drive unit alarm 31: encoder UVW signal error or mismatching the encoder	
0432	Drive unit alarm 32: UVW signal includes fully high level or fully low level	
0433	Drive unit alarm 33: communication interrupted	
0434	Drive unit alarm 34: encoder speed exception	
0435	Drive unit alarm 35: encoder state exception	
0436	Drive unit alarm 36: encoder counting exception	
0437	Drive unit alarm 37: encoder one-loop counting effluence	
0438	Drive unit alarm 38: encoder counting effluence	
0439	Drive unit alarm 39: encoder battery alarm	
0440	Drive unit alarm 40: power shortage of encoder battery	

Alarm No.	Alarm Content	Remarks
0441	Drive unit alarm 41: motor model mismatching	
0442	Drive unit alarm 42: absolute position data exception	
0443	Drive unit alarm 43: encoder EPPROM checking	
0449	Ethernet initialization fails. Please check hardware.	
0450	Drive unit interrupted. Please check whether hardware connection is proper.	
0451	Drive unit alarm of the 1st axis	
0452	Drive unit alarm of the 2nd axis	
0453	Drive unit alarm of the 3rd axis	
0454	Drive unit alarm of the 4th axis	
0455	Drive unit alarm of the 5th axis	
0456	Drive unit alarm of spindle	
0460	Beyond the machining cycles that G71, G72, G73, G76, G90, G92, or G94 can process	
0466	Path non-monotonous: X direction	
0467	Path non-monotonous: Z direction	
0500	Software limit negative over-travel of the 1st axis: (negative movement release in manual or manual pulse mode).	
0501	Software limit negative over-travel of the 1st axis: (negative movement release in manual or manual pulse mode).	
0502	Software limit negative over-travel of the 2nd axis: (positive movement release in manual or manual pulse mode).	
0503	Software limit negative over-travel of the 2nd axis: (negative movement release in manual or manual pulse mode).	
0504	Software limit negative over-travel of the 3rd axis: (positive movement release in manual or manual pulse mode).	
0505	Software limit negative over-travel of the 3rd axis: (negative movement release in manual or manual pulse mode).	
0506	Software limit negative over-travel of the 4th axis: (positive movement release in manual or manual pulse mode).	
0507	Software limit negative over-travel of the 4th axis: (negative movement release in manual or manual pulse mode).	
0508	Software limit negative over-travel of the 5th axis: (positive movement release in manual or manual pulse mode).	
0509	Software limit negative over-travel of the 5th axis: (negative movement release in manual or manual pulse mode).	
0510	Hardware limit negative over-travel of the 1st axis: (over-travel release; positive movement release in manual or manual pulse mode).	
0511	Hardware limit negative over-travel of the 1st axis: (over-travel release; negative movement release in manual or manual pulse mode).	
0512	Hardware limit negative over-travel of the 2nd axis: (over-travel release; positive movement release in manual or manual pulse mode).	
0513	Hardware limit negative over-travel of the 2nd axis: (over-travel release; negative movement release in manual or manual pulse mode).	
0514	Hardware limit negative over-travel of the 3rd axis: (over-travel release; positive movement release in manual or manual pulse mode).	
0515	Hardware limit negative over-travel of the 3rd axis: (over-travel release; negative movement release in manual or manual pulse mode).	
0516	Hardware limit negative over-travel of the 4th axis: (over-travel release; positive movement release in manual or manual pulse mode).	

Appendix II Alarm Table

Alarm No.	Alarm Content	Remarks
0517	Hardware limit negative over-travel of the 4th axis: (over-travel release; negative movement release in manual or manual pulse mode).	
0518	Hardware limit negative over-travel of the 5th axis: (over-travel release; positive movement release in manual or manual pulse mode).	
0519	Hardware limit negative over-travel of the 5th axis: (over-travel release; negative movement release in manual or manual pulse mode).	
0600	Operation keyboard is disconnected. Please check the connecting cable of operation keyboard.	
1001	The address of relay or coil is not set.	
1002	Code input function: The code does not exist.	
1003	Function command: COM is not used properly. The correspondence of COM to COME is wrong, or a function command is used between COM and COME.	
1004	The user ladder graph exceeds the maximum number of lines or steps allowed. (solution) Reduce the number of NETs edited.	
1005	Function command: Neither END1 nor END2 exist; or either END1 or END2 is wrong; or the sequence of END1 and END2 is incorrect.	
1006	Illegal output exists in the network. Please check the output format.	
1007	Hardware fault or system interruption fault causes PLC cannot communicate. Please contact the system equipment manufacturer.	
1008	The function code is not connected properly.	
1009	The network horizontal line is not connected.	
1010	Power failure causes the loss of network in editing of ladder graph.	
1011	The address or the datum is mismatched with the function command format. Please input again.	
1012	The address or the data is inputted improperly. Please input again.	
1013	The specified character is illegal or the datum is out of range.	
1014	CTR address already exists. Please select another CTR address that is not occupied.	
1015	Function command: JMP is inputted improperly; the correspondence of JMP to LBL is wrong; or the JMP function command is used again between JMP and LBL.	
1016	The network structure is incomplete. Modify the ladder graph.	
1017	An unsupported network structure occurs. Modify the ladder graph.	
1019	TMR address has been used. Re-select another TMR address unused.	
1020	Function command is short of parameters. Input legal parameters.	
1021	PLC execution overtime. The system stops PLC automatically. Please check the ladder graph logic and remove the dead cycle or too many calling repetitions.	
1022	Function command name missing. Please input the function command name properly.	
1023	The address or constant of function command parameter is out of range.	
1024	An unnecessary relay or coil exists. Delete unnecessary connections.	
1025	The function command is outputted improperly.	
1026	The number of network connecting lines is out of the supported range. Modify the ladder graph.	
1027	The same output address is used somewhere else. Re-select an output address unused.	

Alarm No.	Alarm Content	Remarks
1028	Ladder graph file format error	
1029	The ladder graph in use is gone.	
1030	Incorrect vertical lines exist in the network. Delete these vertical lines.	
1031	User data zone is full. Please reduce the COD code datatable capacity.	
1032	The first level of ladder graph is too large and cannot be executed in time. Reduce the first level ladder graphs.	
1033	Function command SFT exceeds the maximum amount of use allowed. Please reduce the amount of use.	
1034	Function command DIFU/DIFD address repeated. Please re-select the address.	
1039	The command or network is out of the range of execution. Please remove it.	
1040	Function command CALL or SP is inputted improperly; correspondence between CALL and SP or between SP and SPE is wrong; or SP function command is used again between SP and SPE; or SP is set before the use of END2.	
1041	The horizontal conducting line is connected to node network in parallel.	
1042	PLC system parameter file is not loaded.	